

CANCELLED

DO NOT DESTROY

Chapter 15

PUMP, FUEL, SPE.3536, Mk. 1

LIST OF CONTENTS

	Para.		Para.
<i>Introduction</i>	1	<i>Mounting plate</i>	
Reconditioning		<i>Assembling the mounting plate</i> ...	25
<i>Tools and test equipment</i>	3	<i>Reverse flow leakage test</i>	26
Dismantling		<i>Pump unit</i>	
<i>General</i>	4	<i>Assembling the bellows gland</i> ...	27
<i>Removing the suppression box cover assembly</i>	5	<i>Shaft component checking</i>	28
<i>Separating the pump assembly from the mounting plate</i>	6	<i>Refitting the volute assembly</i> ...	29
<i>Dismantling the mounting plate</i> ...	7	<i>Assembling the upper bearing housing</i>	30
<i>Separating the motor unit from the pump unit</i>	8	<i>Assembling the centrifugal and helical impellers</i>	31
<i>Dismantling the pump unit</i>		<i>Assembling the carbon bearing housing and vapour guide cone</i> ...	32
<i>Removing the inlet filter and carbon bearing housing assembly</i>	9	<i>Completing the assembly of the pump unit</i>	33
<i>Removing the impellers and helix shroud</i>	10	<i>Fitting the motor unit to the pump unit</i>	
<i>Withdrawing the volute assembly</i> ...	11	<i>Bevel pinion shimming</i>	34
<i>Removing the bevel gear and upper bearing assembly</i>	12	<i>Gear alignment</i>	35
<i>Removing the bellows housing assembly and auxiliary fittings</i> ...	13	<i>Securing the motor unit</i>	36
<i>Dismantling the motor unit</i>		<i>Assembling the gearbox</i>	37
<i>Removing the motor end cover</i> ...	14	<i>Assembling the mounting plate to the pump unit assembly</i>	38
<i>Removing the motor bearing housing</i>	15	<i>Pressure testing the pump assembly</i> ...	39
<i>Removing the pinion and dismantling the lower motor case</i>	16	<i>Assembling the terminal block and electrical connection</i>	40
Cleaning, examination and repair		<i>Testing and wirelocking</i>	42
<i>Cleaning</i>	17	Testing	
<i>Examination</i>		<i>General</i>	43
<i>General</i>	18	<i>Test equipment</i>	44
<i>Detailed procedure</i>	19	<i>Preparation</i>	45
Assembling		Schedule of Tests	
<i>General</i>	20	<i>Insulation resistance test</i>	46
<i>Assembling the lower motor case</i> ...	21	<i>Motor speed checking</i>	47
<i>Assembling the motor case bearing</i> ...	22	<i>Gland leakage tests</i>	48
<i>Refitting the motor end cover</i> ...	23	<i>Starting test</i>	49
<i>Torque testing the motor unit</i> ...	24	<i>Dry test</i>	50
		<i>Endurance test</i>	51
		<i>Calibration test</i>	52

~~RESTRICTED~~

LIST OF TABLES

	<i>Table</i>
<i>Special tools and test equipment ...</i>	1
<i>Detailed inspection of components ...</i>	2
<i>Schedule of fits, clearances and repair tolerances</i>	3
<i>Faults, possible causes and remedies ...</i>	4

LIST OF ILLUSTRATIONS

	<i>Fig.</i>		<i>Fig.</i>
<i>Sectional view of mounting plate and gear box</i>	1	<i>Rotor shaft end loading</i>	10
<i>Sectional view of pump outlet ...</i>	2	<i>Valve seat lapping</i>	11
<i>Exploded view of mounting plate assembly</i>	3	<i>Flap valve pressure test</i>	12
<i>Exploded view of pump unit</i>	4	<i>Bellows gland assembly tools</i>	13
<i>Sectional view of pump unit</i>	5	<i>Impeller clearance tools</i>	14
<i>General tools</i>	6	<i>Impeller, helix shroud and helix assembly clearances</i>	15
<i>Bellows gland removal tools</i>	7	<i>Bevel pinion shimming</i>	16
<i>Sectional view of motor unit</i>	8	<i>Backlash checking</i>	17
<i>Exploded view of motor unit</i>	9	<i>Pump pressure testing</i>	18
		<i>Test rig</i>	19

Introduction

1. A general description of the Type SPE.3536 series fuel booster pump is given in A.P.4343D, Vol. 1, Book 2, Sect. 8, Chap. 15. Details of the variations between the different mark numbers are given in A.P.4343D, Vol. 1, Book 2, Sect. 8, Chap. 15, App. 1.

2. The pump assembly comprises a pump unit driven through right-angled reduction gearing by a 200V, 400 c.p.s. 3-phase a.c. motor. Dismantling for reconditioning is carried out in the following four stages. (1) The separation of the pump assembly from the mounting plate. (2) The separation

of the pump and motor units. (3) The dismantling of the pump assembly and (4) Dismantling of the motor unit. During assembly the motor unit and pump unit are built up as two separate sub-assemblies which are then brought together and assembled as a single unit before fitting to the mounting plate.

RECONDITIONING

Tools and test equipment

3. In addition to the standard bench tools, the special tools listed in Table 1 or suitable equivalents are required. Details of a suitable test rig are detailed in para. 44.

~~RESTRICTED~~

TABLE 1
Special tools and test equipment

Nomenclature	Part number	Fig.	Ref. No.
Calibrated fan	SPE.17408	}	6
Gear extractor	SPE.20689		
Pinion extractor	SPE.20690		
Gear wheel key	SPE.20691		
Punch	SPE.20697	}	7
Punch guide	SPE.20698		
Locating block	SPE.20696		
Base plate	SPE.10766		
Lapping plate	SPE.20692	11	
Locating barrel	SPE.20694	}	13
Spindle	SPE.20695		
Locating block	SPE.20693		
Sectioned impeller	SPE.20709	}	14
Sectioned lower bearing housing	SPE.20708		
Motor unit disc	SPE.20705	}	16
Pump unit disc	SPE.20706		
Clamping frame	SPE.20704		
Indexing clamp	SPE.20703		
Clamping screw	SPE.20702		
Starwheel	SPE.20707	}	17
Clamping fixture	SPE.20702/3/4		
Adaptor	SPE.20700	}	18
Gasket	SPE.20701		
Pressure test pipe			
assembly	SPE.20699		

DISMANTLING

General

4. Cut the locking wires to all external seals.

Removing the suppression box cover assembly (fig. 1 & 3)

5. (1) Remove the two screws (125) and shakeproof washers (126) securing the electrical connection plug assembly (128) to the suppression box cover assembly (132).

(2) Remove the cheesehead screws ((130)—2 off: (141)—4 off) and shake-

proof washers ((126)—2 off: (142)—4 off) securing the suppression box cover (132) to the mounting plate.

(3) Do not attempt to remove the motor breather gauze from the suppression box cover unless damaged.

Separating the pump assembly from the mounting plate (fig. 1, 2, 3 & 4)

6. (1) Disconnect the electrical connection plug leads and the motor supply leads at the terminal board by removing the locknuts (137) and shakeproof washers.

RESTRICTED

RESTRICTED

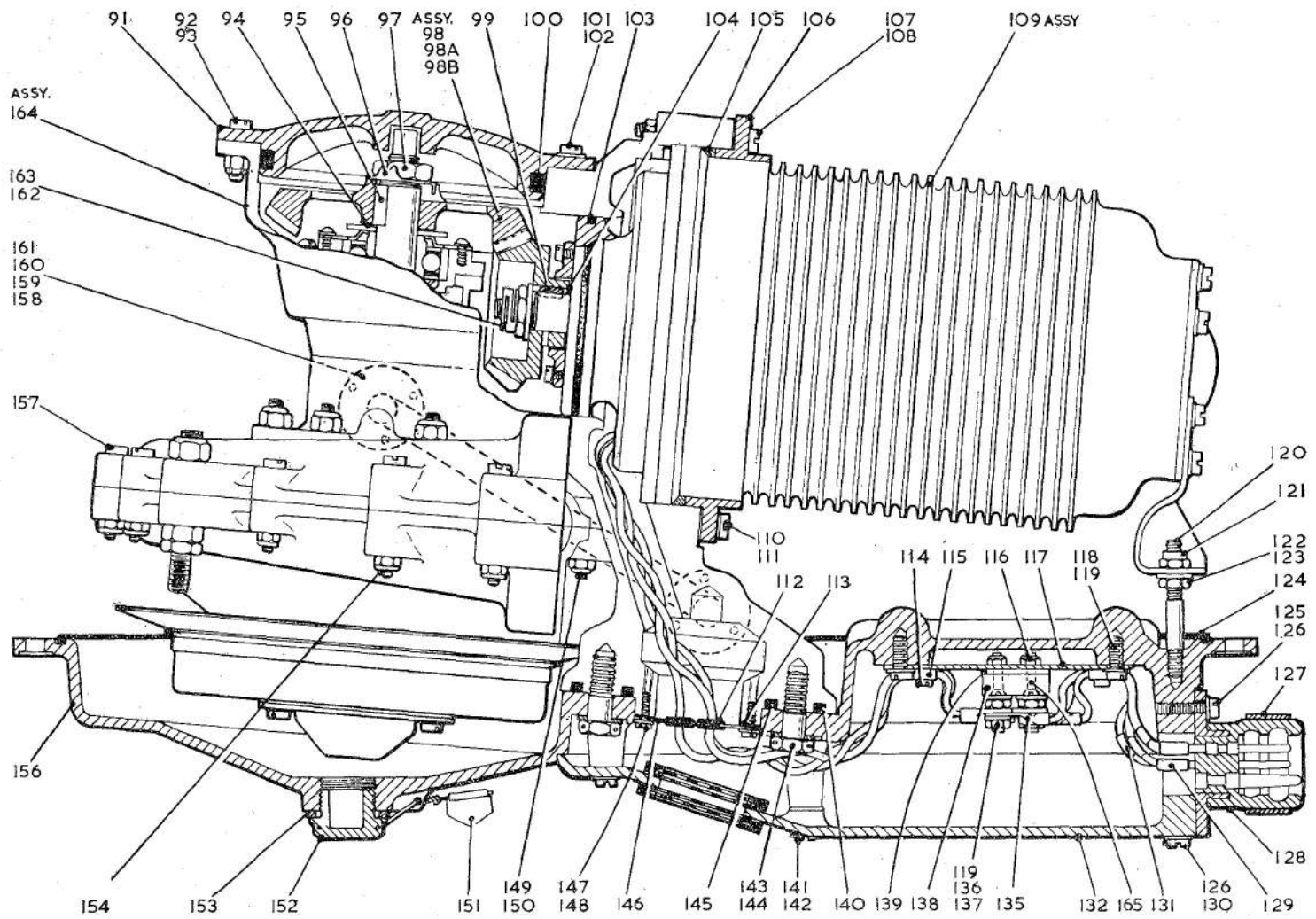

Fig. 1. Sectional view of mounting plate and gear box

Key to Fig. 1

(SECTIONAL VIEW OF MOUNTING PLATE AND GEAR BOX)

91	GEAR BOX COVER			127	QUICK RELEASE CLAMP		
92	CH. HD. SCREW	}	GEAR BOX COVER	128	ELECTRICAL CONNECTION PLUG ASSEMBLY		
93	SELF-LOCKING NUT			}	SECURING	129	INSULATING SLEEVE
94	SHIM					130	CH. HD. SCREW
95	KEY			131	RUBBER SLEEVE		
96	TAB WASHER			132	SUPPRESSION BOX COVER ASSEMBLY		
97	SPINDLE NUT, UPPER			135	TERMINAL TAG		
98A	SPIRAL BEVEL GEAR	}	PAIRED	136	TERMINAL SCREW		
98B	SPIRAL BEVEL PINION					137	LOCKNUT, TAG SECURING
99	KEY			138	TERMINAL BLOCK		
100	SEAL RING			139	TERMINAL BASE COVER		
101	CH. HD. SCREW	}	GEAR BOX COVER	140	SEAL RING		
102	SHAKEPROOF WASHER			}	SECURING	141	CH. HD. SCREW
103	SEAL RING					142	SHAKEPROOF WASHER
104	SHIM			143	BOLT	}	PUMP UNIT SECURING
105	SEAL RING			144	SEALING WASHER		
106	CLAMP RING			145	SEAL RING		
107	CH. HD. SCREW	}	CLAMP RING SECURING	146	MOTOR BREATHER		
108	SELF-LOCKING NUT					147	CH. HD. SCREW
109	MOTOR UNIT ASSEMBLY			148	SHAKEPROOF WASHER		
111	SHAKEPROOF WASHER	}	CLAMP RING SECURING	149	C'S'K. HD. SCREW	}	VOLUTE CASTING CLAMPING
110	CH. HD. SCREW						
112	RUBBER GROMMET			151	SEAL		
113	MOTOR BREATHER PACKING			152	DRAIN PLUG		
114	CH. HD. SCREW			153	SEALING WASHER		
115	CABLE CLAMP			154	CH. HD. SCREW, VOLUTE CLAMPING		
116	SELF-LOCKING NUT			156	MOUNTING PLATE ASSEMBLY		
117	TERMINAL BLOCK MOUNTING PLATE			157	CH. HD. SCREW, VOLUTE CLAMPING		
118	CH. HD. SCREW	}	TERMINAL BLOCK SECURING	158	GLAND DRAIN CONDUIT		
119	SHAKEPROOF WASHER					159	GASKET
120	STUD			160	CH. HD. SCREW		
121	SELF-LOCKING NUT	}	MOTOR UNIT SUPPORTING	161	SHAKEPROOF WASHER	}	PINION SECURING
122	NUT						
123	SHAKEPROOF WASHER			163	PLAIN WASHER		
124	JOINT RING			164	PUMP UNIT ASSEMBLY		
125	CH. HD. SCREW	}	ELECTRICAL CONNECTION SECURING	165	C'S'K. HD. SCREW, TERMINAL BLOCK SECURING		
126	SHAKEPROOF WASHER						

(2) Release the leads from the cable clamps (115) by slackening the screws (114).

(3) Remove the self-locking nuts ((121)—2 off; (170)—1 off) securing the support bracket (15) to the mounting plate studs (120) and the volute casting to the pump support stud (181).

(4) Cut the wirelocking to the exposed bolts (143) and withdraw the bolts and sealing washers (144). Separate the mounting plate assembly from the pump unit at the coupling sleeve (171). Remove the seal rings (140) and (145).

(5) Remove the coupling sleeve (171). Extract and discard the two seal rings (172).

Dismantling the mounting plate assembly (fig. 1, 2 & 3)

7. (1) Remove the remaining two screws (125) and shakeproof washers (126) to detach the electrical connection plug assembly (128). Do not separate the leads from the pins unless damaged.

(2) Remove the four screws (118) and shakeproof washers (119) to detach the terminal block assembly (117). Complete the dismantling of the terminal

RESTRICTED

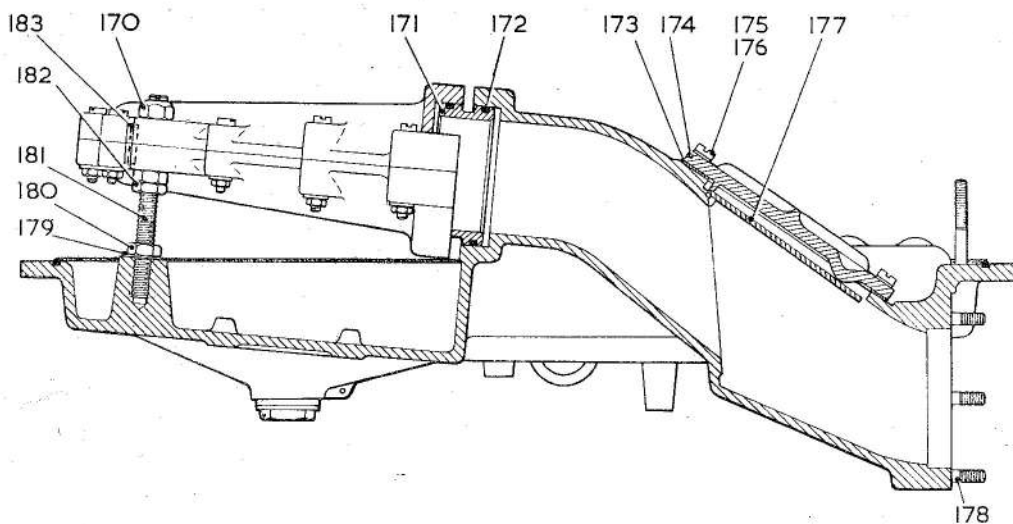

KEY TO FIG. 2

170 SELF-LOCKING NUT		177 VALVE PLATE ASSEMBLY	
171 COUPLING SLEEVE		178 STUD	
172 SEAL RING		179 SPRING WASHER	} PUMP
173 GASKET		180 NUT	
174 BLANKING PLATE	} BLANKING SECURING PLATE	181 STUD	} SUPPORTING
175 CH. HD. SCREW		182 LOCKNUT	
176 SEALING WASHER		183 DOWEL PIN	

Fig. 2. Sectional view of pump outlet

block assembly by removing the three countersunk head screws (165) and self-locking nuts (116) to separate the terminal block (138) and terminal base cover (139) from the terminal block mounting plate sub-assembly (117). Release the terminal screws (136) by removing the locknuts (137) and shakeproof washers (119).

(3) Remove the four screws (175) and bonded seal washers (176) to separate the blanking plate (174) and gasket (173) from the mounting plate assembly. Withdraw the valve plate assembly (177).

(4) Remove the drain plug (152) and seal washer (153).

(5) Remove the nuts (180), locknut (182) and spring washer (179) from the pump support stud (181) and the two shakeproof washers (123) and nuts (122) from the motor support studs (120).

(6) Do not withdraw the studs (181), (120) and (178) unless damaged.

(7) Remove the joint ring (124) cemented in the peripheral groove of the mounting plate (156).

Separating the motor unit from the pump unit (fig. 1 & 4)

8. (1) Remove the copper terminals (135) from the motor unit leads.

(2) Remove the four screws (147) and shakeproof washers (148) to release the motor breather (146) and its packing (113). Withdraw the motor leads and remove the three grommets (112) from the breather gauze.

(3) Remove the eight nuts (93) and withdraw the gear box cover screws (92). Remove the two screws (101) and shakeproof washers (102). Remove the gear box cover (91) and remove as much grease as possible from the gear box. Do not use solvents. Discard the seal ring (100) in the gear box cover.

RESTRICTED

Note . . .

It is strongly recommended that a new gear and pinion are fitted at each overhaul of the pump. These parts are paired prior to assembly and if the original set is to be re-used, the meshing of the gear and pinion should be marked before dismantling, so that on re-assembly the gear and pinion are returned to their original meshed position.

(4) Remove the nuts (108), screws (107:110) and shakeproof washers (111) securing the clamp ring (106). Ease the electrical supply leads back through the channel in the pump casting and withdraw the motor unit assembly (109) together with the seal ring (105).

Dismantling the pump unit

Removing the inlet filter and carbon bearing housing assembly (fig. 4 & 5)

9. (1) Remove the four screws (67) and shakeproof washers (68) securing the lower bearing cover (63) and the filter assembly (71) to the lower bearing housing (58).

(2) Remove the three countersunk head screws (57) and withdraw the vapour guide cone (72).

(3) Bend the washer (62) tabs flat and, holding the gear with the special key SPE.20691 (fig. 6), remove the lower spindle nut (64). Withdraw the lock plate (61).

(4) Remove the six self-locking nuts (73) securing the carbon bearing housing (58) to the volute casting (75). Draw the housing off the studs and the lower bearing sleeve (65).

(5) The carbon bearing (60) should be removed from its housing (58) only if worn (see Table 3). Remove the circlip (66) and press the bearing out of its housing using a hand press and a suitable drift.

(6) Withdraw the lower bearing sleeve (65). Remove the dowel pins (69) only if damaged.

Removing the impellers and helix shroud (fig. 4 & 5)

10. (1) Withdraw the helix (59) from the pump shaft with any shims (70).

(2) Remove the six countersunk head screws (56) securing the helix shroud (54) to the volute casting (75). Remove any shims (55).

(3) Remove the impeller (53), shaft key (52), and any shims (49) fitted.

Withdrawing the volute assembly (fig. 4 & 5)

11. (1) Remove the five self-locking nuts (78) and countersunk head screws (77) securing the impeller shroud plate (76).

(2) Remove the five self-locking nuts (80) and cheesehead screws (79), together with the screw (50) and shakeproof washer (51) securing the volute casting assembly (75) to the pump body casting (85).

(3) The volute assembly need only be dismantled if the seal between the two halves is faulty or the components are damaged. To dismantle the volute assembly remove the thirteen self-locking nuts (150), withdraw the screws ((157)—9 off: (154)—2 off: (149)—2 off) and separate the two halves. Renew any studs (74) as necessary.

Note . . .

Keep the volute halves together as these have been machined as a pair.

Removing the bevel gear and upper bearing assembly (fig. 1, 4 & 5)

12. (1) Bend the washer (96) tabs flat and holding the gear with the special key SPE.20691 (fig. 6) remove the pump shaft nut (97). Using the special extractor tool SPE.20689 (fig. 6) withdraw the gear. Remove any shims (94) fitted and retain the drive key (95).

Note . . .

If it is intended to re-use the gear, it must be paired with the pinion of the motor unit originally fitted to the pump unit.

~~RESTRICTED~~

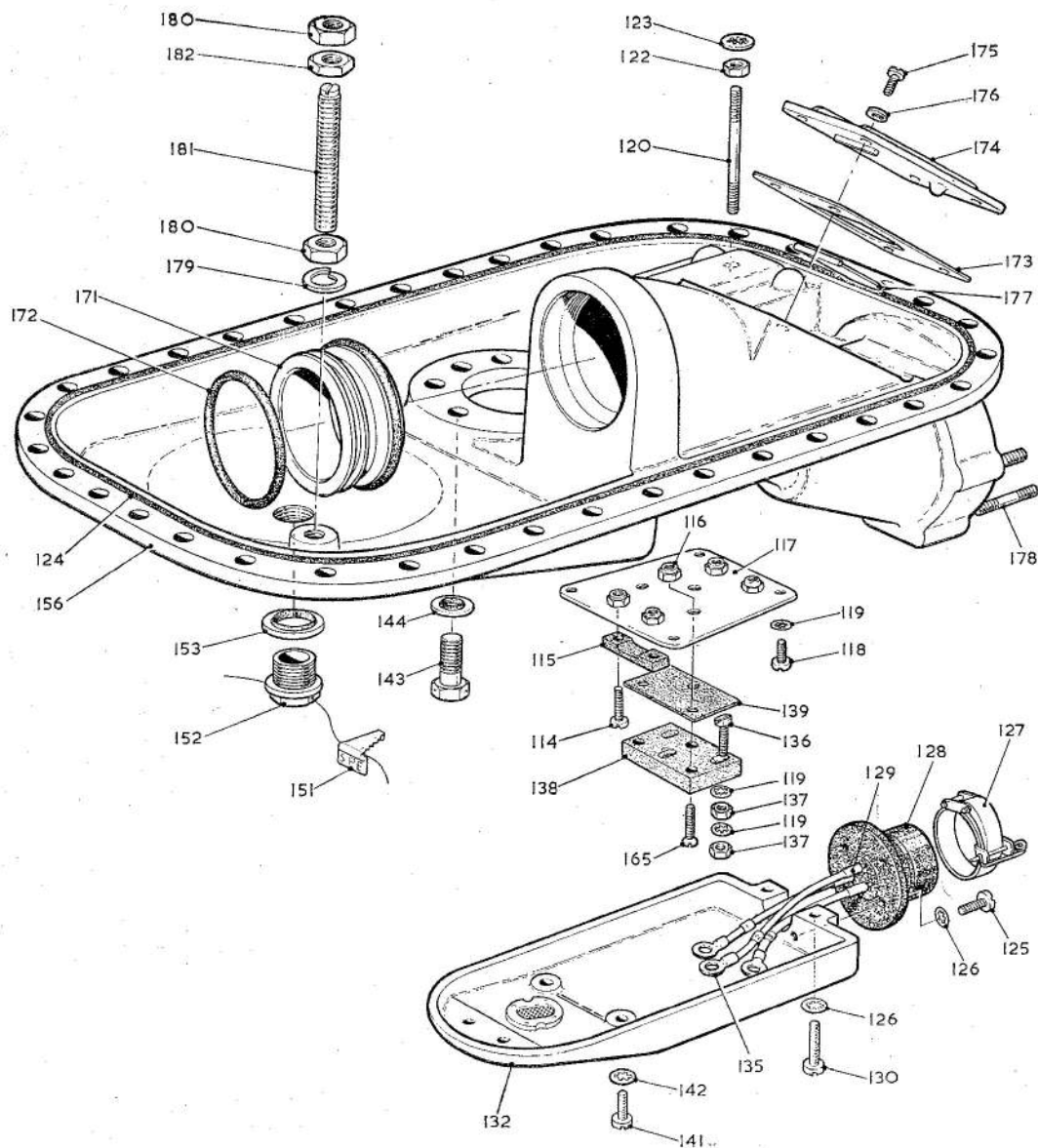

Fig. 3. Exploded view of mounting plate assembly

- (2) Remove the thrower (38) from the pump shaft.
- (3) Remove the five roundhead screws (83) and shakeproof washers (84) securing the upper bearing housing assembly to the pump casting. Break the seal and remove the assembly. Discard the gasket (45).
- (4) Complete the dismantling of the

upper bearing housing by removing the six cheese head screws (35) and shakeproof washers (36) securing the bearing retaining plate (37). Press the bearing (43) out of its housing (44).

- (5) Remove the bellows seal body assembly (82). Extract and discard the seal ring (46). Do not attempt to remove the seal body carbon insert.

RESTRICTED

Key to Fig. 3

91	GEAR BOX COVER			137	LOCKNUT, TAG SECURING		
92	CH. HD. SCREW	}	GEAR BOX COVER	138	TERMINAL BLOCK		
93	SELF-LOCKING NUT			SECURING	139	TERMINAL BASE COVER	
94	SHIM			140	SEAL RING		
95	KEY			141	CH. HD. SCREW	}	SUPPRESSION BOX COVER
96	TAB WASHER			142	SHAKEPROOF WASHER		
97	SPINDLE NUT, UPPER			143	BOLT	}	PUMP UNIT
98A	SPIRAL BEVEL GEAR	}	PAIRED	144	SEALING WASHER		
98B	SPIRAL BEVEL PINION					145	SEAL RING
99	KEY			146	MOTOR BREATHER		
100	SEAL RING			147	CH. HD. SCREW	}	MOTOR BREATHER
101	CH. HD. SCREW	}	GEAR BOX COVER	148	SHAKEPROOF WASHER		
102	SHAKEPROOF WASHER			SECURING		149	C'S'K. HD. SCREW
103	SEAL RING			150	SELF-LOCKING NUT	CLAMPING	
104	SHIM			151	SEAL		
105	SEAL RING			152	DRAIN PLUG		
106	CLAMP RING			153	SEALING WASHER		
107	CH. HD. SCREW	}	CLAMP RING	154	CH. HD. SCREW, VOLUTE CLAMPING		
108	SELF-LOCKING NUT			SECURING		156	MOUNTING PLATE ASSEMBLY
109	MOTOR UNIT ASSEMBLY			157	CH. HD. SCREW, VOLUTE CLAMPING		
110	CH. HD. SCREW	}	CLAMP RING	158	GLAND DRAIN CONDUIT		
111	SHAKEPROOF WASHER			SECURING		159	GASKET
112	RUBBER GROMMET			160	CH. HD. SCREW	SECURING	
113	MOTOR BREATHER PACKING			161	SHAKEPROOF WASHER		
114	CH. HD. SCREW			162	SELF-LOCKING NUT	}	PINION
115	CABLE CLAMP			163	PLAIN WASHER		
116	SELF-LOCKING NUT			164	PUMP UNIT ASSEMBLY		
117	TERMINAL BLOCK MOUNTING PLATE			165	C'S'K. HD. SCREW, TERMINAL BLOCK		
118	CH. HD. SCREW	}	TERMINAL BLOCK		SECURING		
119	SHAKEPROOF WASHER			SECURING		170	SELF-LOCKING NUT
120	STUD			171	COUPLING SLEEVE		
121	SELF-LOCKING NUT	}	MOTOR	172	SEAL RING		
122	NUT			UNIT		173	GASKET
123	SHAKEPROOF WASHER	}	SUPPORTING	174	BLANKING PLATE		
124	JOINT RING					175	CH. HD. SCREW
125	CH. HD. SCREW	}	ELECTRICAL CONNECTION	176	SEALING WASHER	SECURING	
126	SHAKEPROOF WASHER			SECURING		177	VALVE PLATE ASSEMBLY
127	QUICK RELEASE CLAMP			178	STUD		
128	ELECTRICAL CONNECTION PLUG ASSEMBLY			179	SPRING WASHER	}	PUMP
129	INSULATING SLEEVE			180	NUT		
130	CH. HD. SCREW			181	STUD	}	SUPPORTING
131	RUBBER SLEEVE			182	LOCKNUT		
132	SUPPRESSION BOX COVER ASSEMBLY			183	DOWEL PIN		
135	TERMINAL TAG						
136	TERMINAL SCREW						

Removing the bellows housing assembly and ancillary fittings (fig. 1, 4 & 5)

Note . . .

The bellows gland need only be removed if the seal face is badly scored or if the seal is damaged in any way.

13. (1) Using the tools as illustrated in fig. 7 press out the metallic bellows gland (81). Discard the seal ring (48).

(2) Remove the six cheesehead screws (160) and shakeproof washers (161) to

detach the gland drain conduit (158). Discard the gaskets (159).

Dismantling the motor unit

Removing the motor end cover (fig. 8 & 9)
14. Remove the six cheesehead screws (6) and spring washers (7) securing the motor end cover (11) and motor support bracket (15) to the motor casing. Withdraw the end cover. Discard the seal ring (14).

Removing the motor bearing housing (fig. 1, 4, 8 & 9)

15. (1) Holding the pinion (98B) to prevent the rotor (21) from turning,

~~RESTRICTED~~

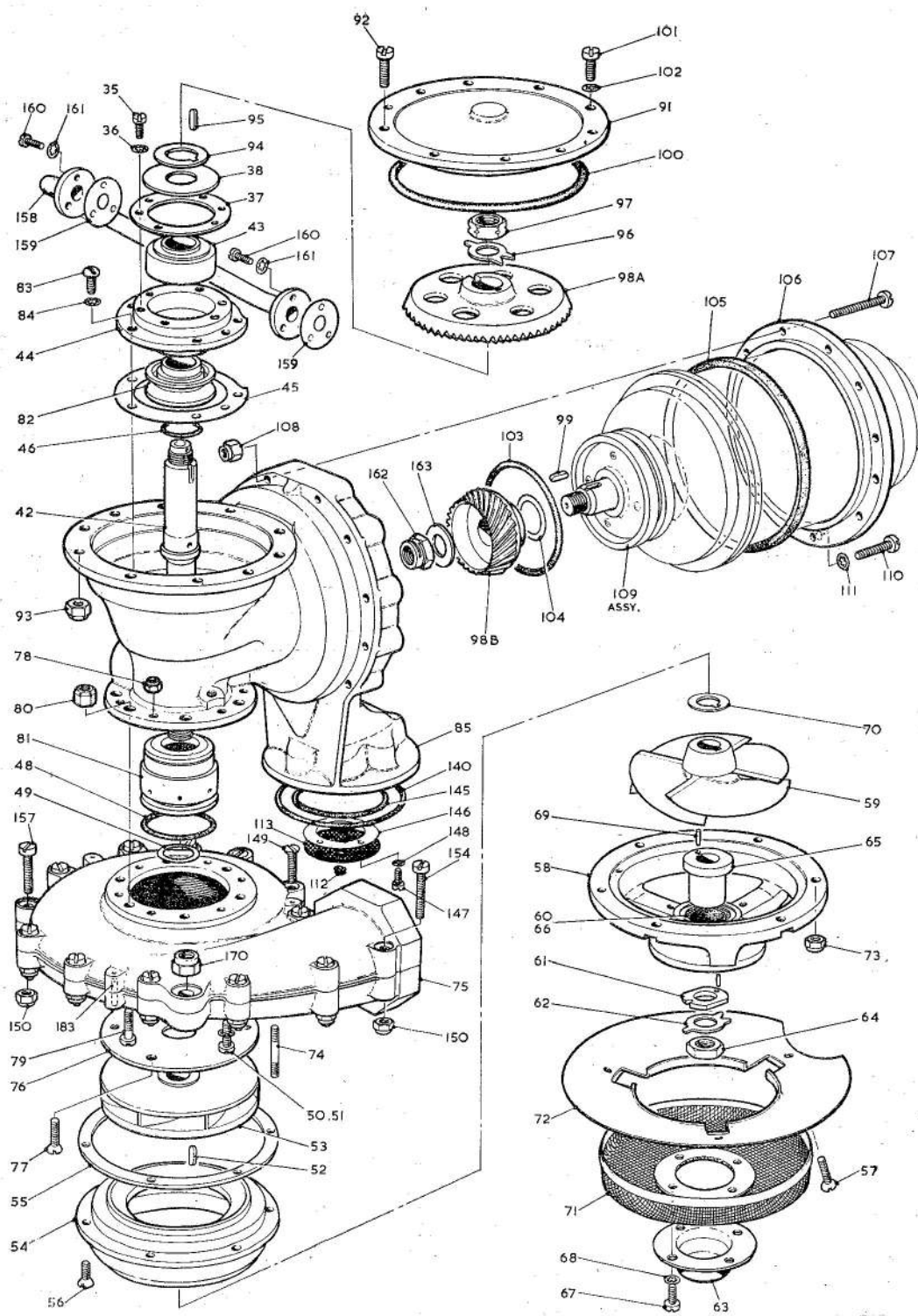

Fig. 4. Exploded view of pump unit

RESTRICTED

Key to Fig. 4

35 CH. HD. SCREW	} RETAINING PLATE	103 SEAL RING
36 SHAKEPROOF WASHER		104 SHIM
37 RETAINING PLATE	} SECURING	105 SEAL RING
38 THROWER		106 CLAMP RING
39 DISTANCE PIECE	} TEMPORARY	107 CH. HD. SCREW
40 SHAKEPROOF WASHER		108 SELF-LOCKING NUT
41 NUT		109 MOTOR UNIT ASSEMBLY
42 PUMP SPINDLE	} CLAMP RING	110 CH. HD. SCREW
43 BALL BEARING		111 SHAKEPROOF WASHER
44 UPPER BEARING HOUSING	} SECURING	112 RUBBER GROMMET
45 GASKET		113 MOTOR BREATHER PACKING
46 SEAL RING	} CLAMP RING	114 CH. HD. SCREW
48 SEAL RING		115 CABLE CLAMP
49 SHIM	} SECURING	116 SELF-LOCKING NUT
50 CH. HD. SCREW		117 TERMINAL BLOCK MOUNTING PLATE
51 SHAKEPROOF WASHER	} VOLUTE	118 CH. HD. SCREW
52 KEY		119 SHAKEPROOF WASHER
53 IMPELLER	} SECURING	120 STUD
54 HELIX SHROUD		121 SELF-LOCKING NUT
55 SHIM	} MOTOR	122 NUT
56 C'S'K. HD. SCREW		123 SHAKEPROOF WASHER
57 C'S'K. HD. SCREW	} UNIT	124 JOINT RING
58 LOWER BEARING HOUSING		125 CH. HD. SCREW
59 HELIX	} ELECTRICAL	126 SHAKEPROOF WASHER
60 CARBON BEARING		127 QUICK RELEASE CLAMP
61 LOCK PLATE	} CONNECTION	128 ELECTRICAL CONNECTION PLUG ASSEMBLY
62 TAB WASHER		129 INSULATING SLEEVE
63 LOWER BEARING COVER	} SECURING	130 CH. HD. SCREW
64 SPINDLE NUT, LOWER		131 RUBBER SLEEVE,
65 LOWER BEARING SLEEVE	} SUPPRESSION	132 SUPPRESSION BOX COVER ASSEMBLY
66 CIRCLIP		133 TERMINAL TAG
67 CH. HD. SCREW	} LOWER BEARING	134 TERMINAL SCREW
68 SHAKEPROOF WASHER		135 TERMINAL SCREW
69 DOWEL PIN	} COVER SECURING	136 TERMINAL SCREW
70 SHIM		137 LOCKNUT, TAG SECURING
71 FILTER ASSEMBLY	} SECURING	138 TERMINAL BLOCK
72 VAPOUR GUIDE CONE		139 TERMINAL BASE COVER
73 SELF-LOCKING NUT	} SUPPRESSION	140 SEAL RING
74 STUD		141 CH. HD. SCREW
75 VOLUTE CASTING	} BOX COVER	142 SHAKEPROOF WASHER
76 IMPELLER SHROUD PLATE		143 BOLT
77 C'S'K. HD. SCREW	} PUMP UNIT	144 SEALING WASHER
78 SELF-LOCKING NUT		145 SEAL RING
79 CH. HD. SCREW	} SECURING	146 MOTOR BREATHER
80 SELF-LOCKING NUT		147 CH. HD. SCREW
81 BELLOWS GLAND ASSEMBLY	} MOTOR BREATHER	148 SHAKEPROOF WASHER
82 BELLOWS SEAL BODY ASSEMBLY		149 C'S'K. HD. SCREW
83 RD. HD. SCREW	} SECURING	150 SELF-LOCKING NUT
84 SHAKEPROOF WASHER		151 SEAL
85 PUMP BODY CASTING ASSEMBLY	} VOLUTE CASTING	152 DRAIN PLUG
91 GEAR BOX COVER		153 SEALING WASHER
92 CH. HD. SCREW	} GEAR BOX COVER	154 CH. HD. SCREW, VOLUTE CLAMPING
93 SELF-LOCKING NUT		155 MOUNTING PLATE ASSEMBLY
94 SHIM	} SECURING	156 CH. HD. SCREW, VOLUTE CLAMPING
95 KEY		157 GLAND DRAIN CONDUIT
96 TAB WASHER	} GLAND DRAIN	158 GASKET
97 SPINDLE NUT, UPPER		159 CH. HD. SCREW
98A SPIRAL BEVEL GEAR	} CONDUIT	160 CH. HD. SCREW
98B SPIRAL BEVEL PINION		161 SHAKEPROOF WASHER
99 KEY	} SECURING	162 SELF-LOCKING NUT
100 SEAL RING		163 PLAIN WASHER
101 CH. HD. SCREW	} PINION	164 PUMP UNIT ASSEMBLY
102 SHAKEPROOF WASHER		165 C'S'K. HD. SCREW, TERMINAL BLOCK
		SECURING

~~RESTRICTED~~

Key to Fig. 4 (contd.)

170 SELF-LOCKING NUT		177 VALVE PLATE ASSEMBLY	
171 COUPLING SLEEVE		178 STUD	
172 SEAL RING		179 SPRING WASHER	} PUMP UNIT SUPPORTING
173 GASKET		180 NUT	
174 BLANKING PLATE		181 STUD	
175 CH. HD. SCREW	} BLANKING PLATE SECURING	182 LOCKNUT	
176 SEALING WASHER		183 DOWEL PIN	

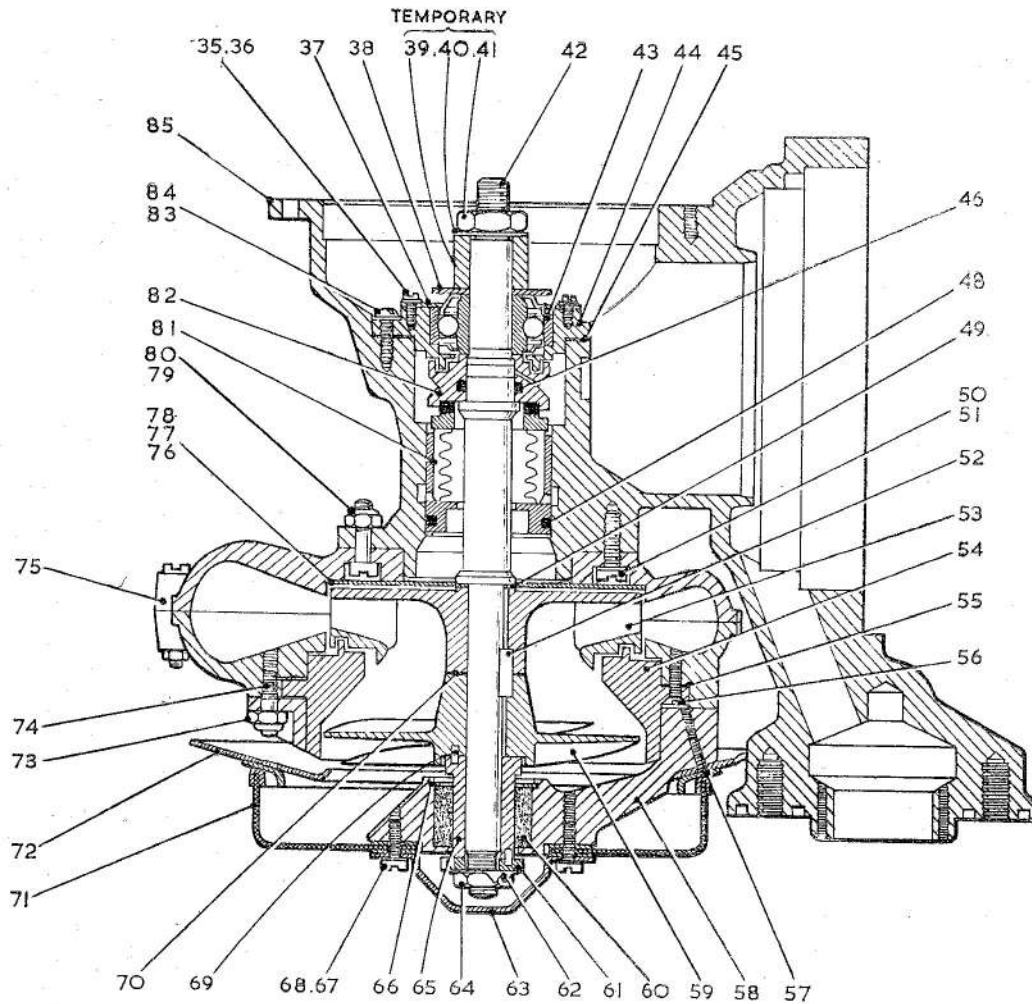

Fig. 5. Sectional view of pump unit

~~RESTRICTED~~

Key to Fig. 5

(SECTIONAL VIEW OF PUMP UNIT)

35 CH. HD. SCREW	} RETAINING PLATE SECURING	60 CARBON BEARING
36 SHAKEPROOF WASHER		61 LOCK PLATE
37 RETAINING PLATE		62 TAB WASHER
38 THROWER		63 LOWER BEARING COVER
39 DISTANCE PIECE	} TEMPORARY PARTS ONLY	64 SPINDLE NUT, LOWER
40 SHAKEPROOF WASHER		65 LOWER BEARING SLEEVE
41 NUT		66 CIRCLIP
42 PUMP SPINDLE		67 CH. HD. SCREW
43 BALL BEARING		68 SHAKEPROOF WASHER
44 UPPER BEARING HOUSING		69 DOWEL PIN
45 GASKET		70 SHIM
46 SEAL RING		71 FILTER ASSEMBLY
48 SEAL RING		72 VAPOUR GUIDE CONE
49 SHIM		73 SELF-LOCKING NUT
50 CH. HD. SCREW	} VOLUTE SECURING	74 STUD
51 SHAKEPROOF WASHER		75 VOLUTE CASTING
52 KEY		76 IMPELLER SHROUD PLATE
53 IMPELLER		77 C'S'K. HD. SCREW
54 HELIX SHROUD		78 SELF-LOCKING NUT
55 SHIM		79 CH. HD. SCREW
56 C'S'K. HD. SCREW	} HELIX SHROUD SECURING	80 SELF-LOCKING NUT
57 C'S'K. HD. SCREW		81 BELLOWS GLAND ASSEMBLY
58 LOWER BEARING HOUSING	} VAPOUR GUIDE CONE SECURING	82 BELLOWS SEAL BODY ASSEMBLY
59 HELIX		83 RD. HD. SCREW
		84 SHAKEPROOF WASHER
		85 PUMP BODY CASTING ASSEMBLY

RESTRICTED

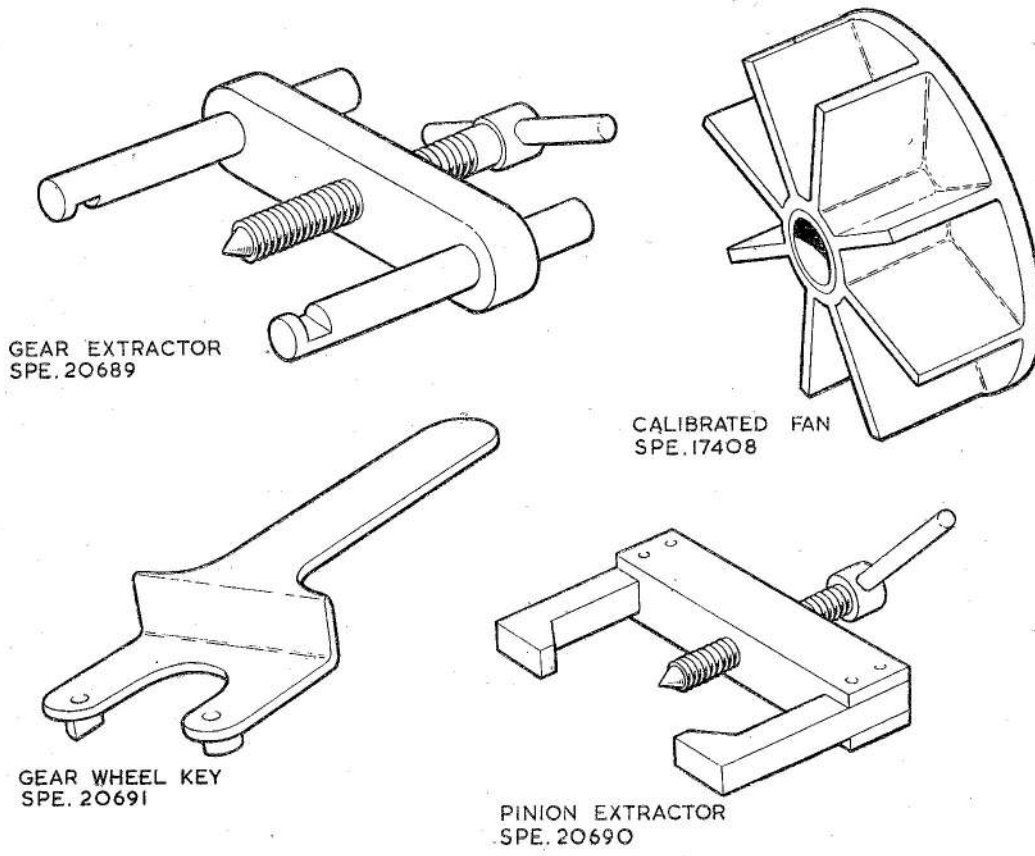

Fig. 6. General tools

~~RESTRICTED~~

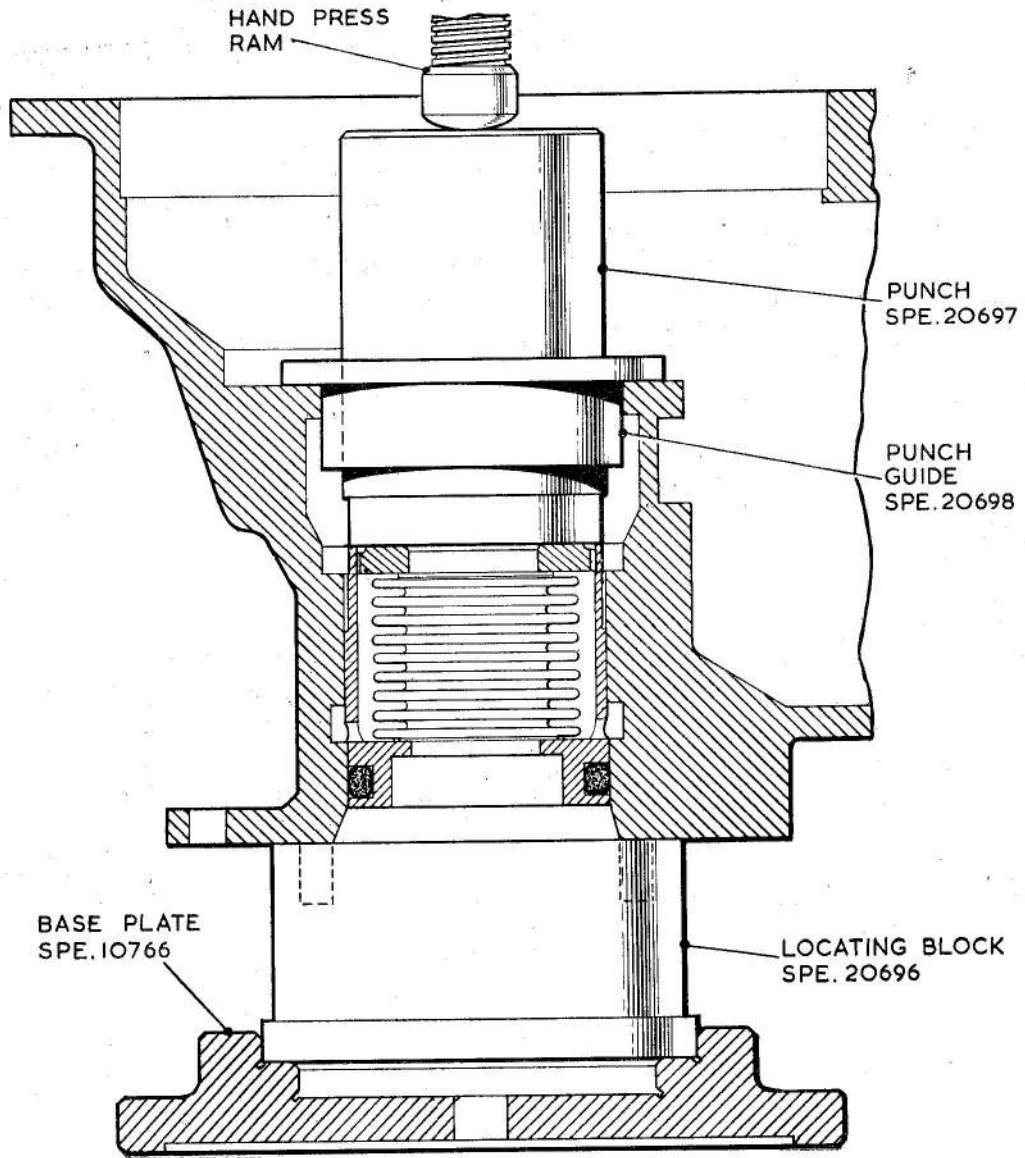
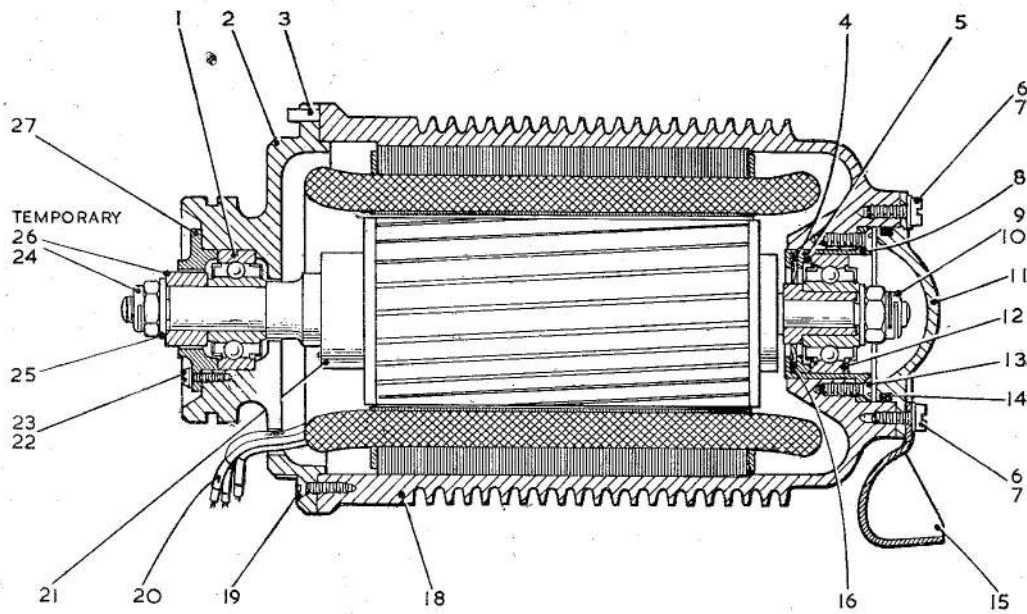

Fig. 7. Bellows gland removal tools

RESTRICTED



- | | |
|-----------------------------------|------------------------------------|
| 1 BALL BEARING | 15 SUPPORT BRACKET |
| 2 LOWER MOTOR CASE | 16 BEARING PRE-LOAD WASHER |
| 3 DOWEL PIN | 18 MOTOR CASE AND STATOR ASSEMBLY |
| 4 ADJUSTING WASHER | 19 C'S'K. HD. SCREW |
| 5 BEARING RING | 20 RUBBER SLEEVE |
| 6 CH. HD. SCREW } MOTOR END COVER | 21 ROTOR ASSEMBLY |
| 7 SPRING WASHER } SECURING | 22 RD. HD. SCREW } RETAINING PLATE |
| 8 MOTOR BEARING HOUSING | 23 SPRING WASHER } SECURING |
| 9 SHAFT NUT } NON-DRIVING | 24 NUT } TEMPORARY |
| 10 PLAIN WASHER } END | 25 PLAIN WASHER } PARTS |
| 11 MOTOR END COVER | 26 DISTANCE PIECE } ONLY |
| 12 BALL BEARING | 27 RETAINING PLATE |
| 13 C'S'K. HD. SCREW | |
| 14 SEAL RING | |

Fig. 8. Sectional view of motor unit

Key to Fig. 9

- | | |
|-----------------------------------|------------------------------------|
| 1 BALL BEARING | 15 SUPPORT BRACKET |
| 2 LOWER MOTOR CASE | 16 BEARING PRE-LOAD WASHER |
| 3 DOWEL PIN | 18 MOTOR CASE AND STATOR ASSEMBLY |
| 4 ADJUSTING WASHER | 19 C'S'K. HD. SCREW |
| 5 BEARING RING | 20 RUBBER SLEEVE |
| 6 CH. HD. SCREW } MOTOR END COVER | 21 ROTOR ASSEMBLY |
| 7 SPRING WASHER } SECURING | 22 RD. HD. SCREW } RETAINING PLATE |
| 8 MOTOR BEARING HOUSING | 23 SPRING WASHER } SECURING |
| 9 SHAFT NUT } NON-DRIVING | 24 NUT } TEMPORARY |
| 10 PLAIN WASHER } END | 25 PLAIN WASHER } PARTS |
| 11 MOTOR END COVER | 26 DISTANCE PIECE } ONLY |
| 12 BALL BEARING | 27 RETAINING PLATE |
| 13 C'S'K. HD. SCREW | |
| 14 SEAL RING | |

~~RESTRICTED~~

release the shaft nut (9) and remove the washer (10).

(2) Remove the eight countersunk head screws (19) securing the lower motor case (2) to the motor case and stator assembly (18).

(3) Carefully draw the motor case and stator assembly off the spigot of the lower motor case, and the rotor shaft out of the bearing (12).

(4) Remove the six countersunk head screws (13) securing the bearing housing (8) to the motor casing. Press the housing out of the motor case.

(5) Press the bearing (12) out of its housing together with the bearing ring (5), adjusting washers (4) if fitted, and the pre-load washer.

Removing the pinion and dismantling the lower motor case (fig. 1, 4, 8 & 9)

16. (1) Hold the pinion and remove the self-locking nut (162) together with the washer (163). Draw off the pinion (98B) using the special extractor tool SPE. 20690 (fig. 6) and retain the shaft key (99).

Note . . .

If the pinion is to be re-used, ensure that it is paired with the gear removed from the associated pump unit (para. 12).

(2) Remove the four round head screws (22) and spring washers (23) securing the retaining plate (27) to the lower motor case (2). Remove the retaining plate and press the bearing (1) out of its housing.

(3) Discard the seal ring (103).

CLEANING, EXAMINATION AND REPAIR

Cleaning

17. Immerse the rotor and field assembly if greasy in white spirit and use a soft bristle brush to clean. After cleaning, blow off the surplus spirit and allow the components to dry out for several hours. Complete the drying in a ventilated oven at approximately 93°C. Ensure that all dried jointing compound is removed from the pump and mounting plate mating surfaces, using an approved remover if necessary. All parts except the electrical connection, bearings, and synthetic material or rubber components should be cleaned in a dry cleaning solvent, or if excessively dirty, in a heavy duty degreasant. After cleaning, allow to dry out for 12 hours and complete the drying in a ventilated oven.

Examination

General

18. Examine all metal components visually for cleanliness, distortion, cracking, scoring, denting, evidence of wear, deterioration of protective finishes (corrosion), serviceability of threads, security of sub-assemblies not normally dismantled (rivetting etc.), and discoloration due to overheating. Examine reusable rubber components and electrical cable insulation for cleanliness, cuts, chafing, cracking, overheating, fluid soakage and general deterioration. All seal rings and gaskets must be renewed on re-assembly. It is also recommended that both the bearings and the gear and pinion assembly are renewed whenever the pump is reconditioned.

Detailed procedure

19. Parts should be examined in accordance with Table 2 and checked for conformity with the Schedule of Fits, Clearances and Repair Tolerances given in Table 3.

RESTRICTED

TABLE 2
Detailed inspection of components

Item	Inspection	Action if faulty
Rotor assembly	Insulation resistance to shaft. Use a 500 volt constant pressure insulation resistance tester.	Clean thoroughly using white spirit. Dry for a prolonged period at 93°C. Allow the rotor to cool. Check that the insulation resistance is not less than 50 megohms. If below this figure continue drying process. Cool. Recheck.
	Fouling of rotor on stator bore.	Check shaft for concentricity and side-play of bearings.
	Rotor shaft for concentricity.	Maximum eccentricity 0.025 mm. (0.001 in.).
Motor case and stator assembly	Charring or other evidence of overheating.	Renew complete assembly.
	Resistance per phase 1.38 ohms \pm 5%.	Renew complete assembly.
	Condition of stator windings.	If damaged, renew complete assembly.
	Insulation resistance of stator windings to frame.	Clean thoroughly using white spirit. Dry for prolonged period at 93°C. Allow to cool. Check that the insulation resistance reading is not less than 50 megohms. If below this figure, continue the drying process. Cool. Re-check.
	Condition of stator lead coverings.	If damaged, cover with additional sleeving.
Bearing pre-load washer	Load of between 11.5 and 14.0 lb. (5.22/6.35 Kg) to compress washer to 0.060 in. (1.50 mm.) overall thickness.	Renew.
Metallic bellows gland	Scoring of seal face.	If slight, relap to a mirror finish. If excessive, renew.
	Damage to bellows unit convolutions.	Renew unit.

~~RESTRICTED~~

TABLE 2—(contd.)

Item	Inspection	Action if faulty
Plain carbon bearing (pump unit)	Damaged or cracked carbon. Excessive wear.	Renew carbon bearing (press fit in housing). Bore and ream to size—see Table 3.
Seal body	Damaged or cracked carbon.	Renew seal body assembly complete.
	Excessive wear (See Table 2).	Renew seal body assembly complete.
Gaskets and joint rings	Renew at each overhaul.	Renew.
By-pass flap valve	Damaged rubber seating or scored or damaged seal face (alternative components).	Renew.
	Worn pivot.	Renew.
Filter assembly	Damaged wire mesh.	Renew.
Electrical connection	Damaged contact pins.	Renew plug.
Bevel gear and pinion	It is recommended that a new gear and pinion are fitted at each overhaul of the pump. If components are to be re-used, it is essential that parts are kept together when dismantling and rebuilt into the same pump assembly with identical meshing.	

~~RESTRICTED~~

TABLE 3

Schedule of fits, clearances and repair tolerances

Part and Description	Dimensions New	Permissible worn dimensions for re-use	Clearances New	Permissible worn clearance for re-use	Remarks
MOTOR UNIT					
Rotor end float	—	—	0.005 in. max. (0.125 mm.)	0.008 in. max. (0.2 mm.)	
Rotor shaft in drive end ball-race	{ 11.995 mm. 11.985 mm. (0.4723 in.) (0.4719 in.)	—	—	—	Inner race clamped to shaft on both faces.
—diameter					
—bore	{ 12.00 mm. 11.990 mm. (0.4724 in.) (0.4721 in.)	—	—	—	Selective assembly.
Rotor shaft in outer ball race	{ 11.995 mm. 11.985 mm. (0.4723 in.) (0.4719 in.)	—	—	—	Inner race clamped to shaft on both faces.
—diameter					
—bore	{ 12.00 mm. 11.990 mm. (0.4724 in.) (0.4721 in.)	—	—	—	Selective assembly

RESTRICTED

TABLE 3—(contd.)

Part and Description	Dimensions New	Permissible worn dimensions for re-use	Clearances New	Permissible worn clearance for re-use	Remarks
PUMP UNIT					
Pump shaft in upper ball-race —diameter	{ 11.995 mm. 11.985 mm. (0.4723 in.) (0.4719 in.)	—	—	—	Inner race clamped to shaft on both faces. Selective assembly.
—bore	{ 12.00 mm. 11.990 mm. (0.4724 in.) (0.4721 in.)	—	—	—	
Lower bearing sleeve in plain carbon bearing —diameter	{ 15.850 mm. 15.825 mm. (0.6240 in.) (0.6230 in.)	15.824 mm. (0.623 in.)	0.055 mm. 0.099 mm.	0.099 mm.	Free running shaft in supported fuel lubricated plain bearing. Bore to be concentric with 92 mm. diameter of housing to within 0.03 mm. (0.012 in.).
—bore	{ 15.925 mm. 15.905 mm. (0.6270 in.) (0.6262 in.)	15.925 mm. (0.627 in.)	(0.0022 in.) (0.004 in.)	(0.004 in.)	
Centrifugal impeller to impeller shroud plate clearance (dim. A., fig. 15)	—	—	0.254 mm. 0.508 mm. (0.010 in.) (0.020 in.)	—	Adjust clearance as detailed in para. 31(1-4).

RESTRICTED

TABLE 3—(contd.)

Part and Description	Dimensions New	Permissible worn dimensions for re-use	Clearances New	Permissible worn clearance for re-use	Remarks
Helix shroud to centrifugal impeller clearance (Dim. B., fig. 15)	—	—	0.127 mm. 0.254 mm. (0.005 in.) (0.010 in.)	—	Adjust clearance as detailed in para. 31(5,6).
Projection of impeller helix blade tips beyond open end of helix shroud (Dim. C., fig. 15)	1.0 mm. 1.5 mm. (0.040 in.) (0.060 in.)	—	—	—	Adjust projection as detailed in para. 31(7).

ASSEMBLING

General

20. Preserve absolute cleanliness of the work bench and tools throughout the assembly of the pump. Retain the bearings in their wrappings until they are required for assembly. Always use the special tools provided where specified.

Motor unit

Assembling the lower motor case (fig. 8 & 9)

21. (1) Pre-select a new bearing (1) that is a slide fit under thumb pressure both on the rotor shaft (21) and in the lower motor case (2). Retain the rotor and end case and suitably mark both so that they can be paired with the selected bearing at a later assembly stage. Check that the selected bearing is smooth running with no roughness when the inner race is rotated by hand.

(2) Check that the bearing housing in the lower motor case (2) is perfectly clean and that the wall surface is smooth and free of score marks, burrs, and adhering swarf. Insert the selected

bearing. Fit the bearing retaining plate (27) over the bearing and secure with four round head screws (22) and spring washers (23).

Assembling the motor case bearing (fig. 8 & 9)

22. (1) Pre-select a new bearing (12) that is a slide fit under thumb pressure on the selected rotor shaft (para. 21). Check that the bearing is smooth running with no roughness when rotated by hand. Check also that selected bearing is a slide fit under thumb pressure in the motor bearing housing (8).

(2) Fit the motor bearing housing (8) to the motor case and stator assembly (18) and secure with the six counter-sunk head screws (13).

(3) Insert the selected rotor (21) through the bearing fitted to the lower motor case (para. 21) and retain with the temporary distance piece (26), plain washer (25) and self-locking shaft nut (24).

RESTRICTED

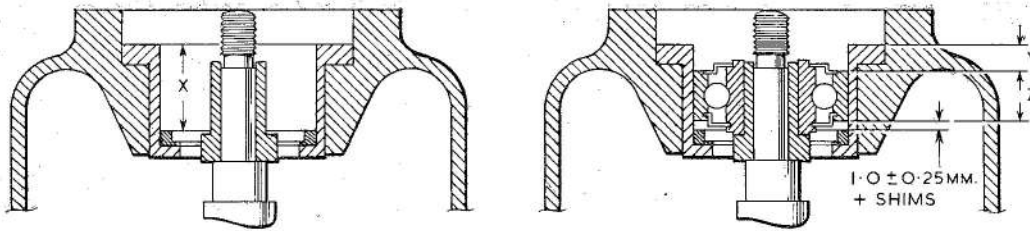

Fig. 10. Rotor shaft end loading

(4) Carefully pass the rotor assembly through the bore of the stator assembly, locating the dowel (3) in the rim of the motor case in the location hole in the lower motor case (2). Bring the three stator leads out through the slot in the lower motor case and secure this latter component (2) to the motor case (18) with the eight countersunk head screws (19). Tighten securely. The three leads should be identified by numbered rubber sleeves (20).

(5) Supporting the motor unit vertically in a suitable holding block, drop the bearing ring (5) into position in the motor bearing housing (8). Using a depth micrometer check the distance between the flanged surface of the bearing housing and the top face of the bearing ring (5) (dim. X fig. 10).

(6) Fit the selected bearing (12) (para. 22(1)) over the rotor shaft and press into the housing so that it contacts the shoulder of the rotor shaft. With a depth micrometer check the distance between the flanged surface of the bearing housing and the outer race of the housing (12) (dim. Y fig. 10).

(7) The gap between the bearing ring (5) and the bearing is now given by subtracting dim. Y plus the thickness of the outer race of the bearing (dim. Z) from dim. X. This dimension less 1.0 ± 0.25 mm. allowance for the compressed pre-load washer (16) will give the thickness of adjusting washers (4) required to correctly pre-load the washer. If the gap for the pre-load washer works out at less than 1.0mm. it will be necessary to machine the front face of the motor case and stator assembly at right angles to the stator bore to obtain the necessary pre-load conditions.

(8) Withdraw the bearing (12) and bearing ring (5) from the motor bearing housing. Insert the pre-load washer (16) followed by adjusting washers (4) of the total thickness previously calculated (sub-para. 7). Re-position the bearing ring (5) with the counter-bored face uppermost and replace the selected bearing (12).

(9) Secure the inner race of the bearing with a $\frac{5}{16}$ in. B.S.F. plain washer (10) and the self-locking nut (9). Securely tighten.

(10) Check that the rotor rotates without any indication of interference.

Refitting the motor end cover (fig. 8 & 9)

23. (1) Fit a new seal ring (14) in the spigot groove of the motor end cover (11). Lubricate the seal ring with a smear of Silicone MS.4 compound A.339, Ref. No. 33C/9424829 and position the cover on the motor case. Secure with six cheesehead screws (6) and spring washers (7), fitting the support bracket (15) under the two screws which are in line with the stator lead slot in the lower motor case (2). Tighten the screws.

Torque testing the motor unit

24. The motor unit should now be tested in accordance with the details given in para. 47. Failure to meet the required performance will reject the unit.

Mounting plate

Assembling the mounting plate (fig. 1, 2 & 3)

25. (1) Replace any damaged studs (178) in the mounting plate (156).
- (2) Fit a new joint ring (124) in the peripheral groove of the mounting plate.

RESTRICTED

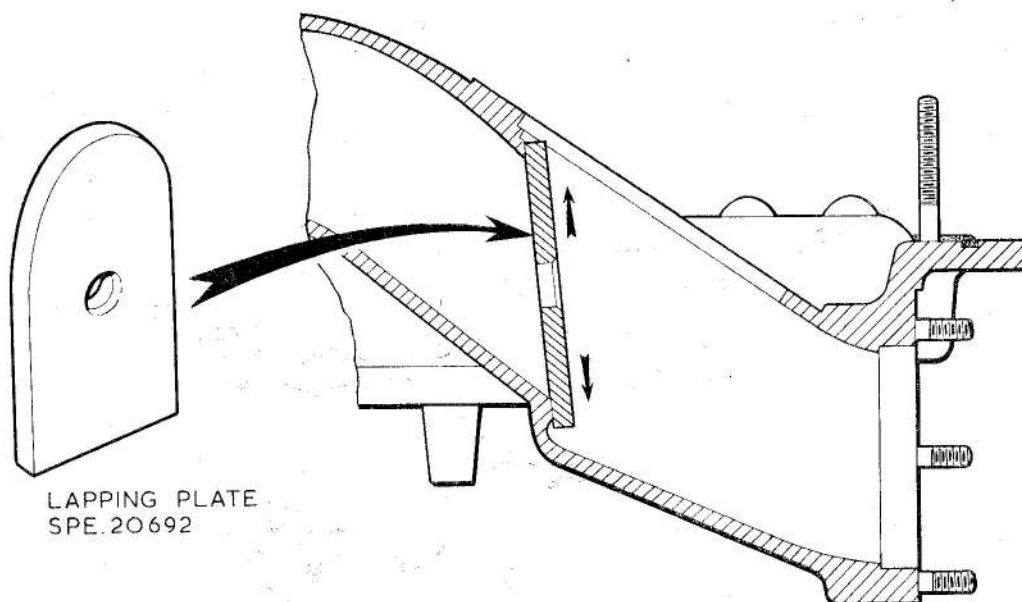

Fig. 11. Valve seat lapping

Proceed as follows:

- (a) Remove all flash from the corners of the joint ring.
 - (b) Ensure that all dried jointing compound has been cleaned from the groove in the mounting plate. Clean the contact surface with 'Boscoprene' Cleaner No. 4.
 - (c) Prime the surface with 'Boscolite' Primer No. 147A and allow to dry for at least one hour.
 - (d) Coat the groove with 'Boscoprene' Cement J.761, parts A and B. Allow to dry for at least half an hour.
 - (e) Add a second coat of J.761 Cement and allow to dry for 15 minutes.
 - (f) Assemble the ring (124) to the groove. Feed the ring into the groove by short lengths, but do not stretch the rubber. **DO NOT LET THE CEMENT CONTAMINATE THE SEALING EDGE OF THE SEAL.**
 - (g) Allow the assembly to cure for 24 hours at room temperature.
- (3) Using the special lapping plate SPE.20692 (fig. 11) and fine grinding

paste, lap the valve plate seating in the mounting plate, using a back and forth rotary movement of the lapping plate under finger pressure. Finish using a metal polish as the grinding medium. Thoroughly wash out the assembly to remove all traces of the grinding paste.

(4) Locate the hinge pins of the valve plate (177) in the location slots of the mounting plate delivery outlet. When using valve plates with a bonded rubber seating, the rubber should face into the delivery outlet duct so that the plate hinges with the rubber contacting the lapped seating.

(5) Fit a new gasket (173) and position the blanking plate (174). Secure with four cheesehead screws (175) and bonded seal washers (176). Check that the valve plate hinges freely.

(6) Refit the drain plug (152) and bonded seal washer (153).

(7) Refit the pump support studs (181) and (120—2 off) if removed. To the larger stud (181) fit a spring washer (179), nut (180), locknut (182) and nut (180), in that order. Do not tighten at this stage. To the smaller studs (120) fit a locknut (122) and a shakeproof washer (123).

RESTRICTED

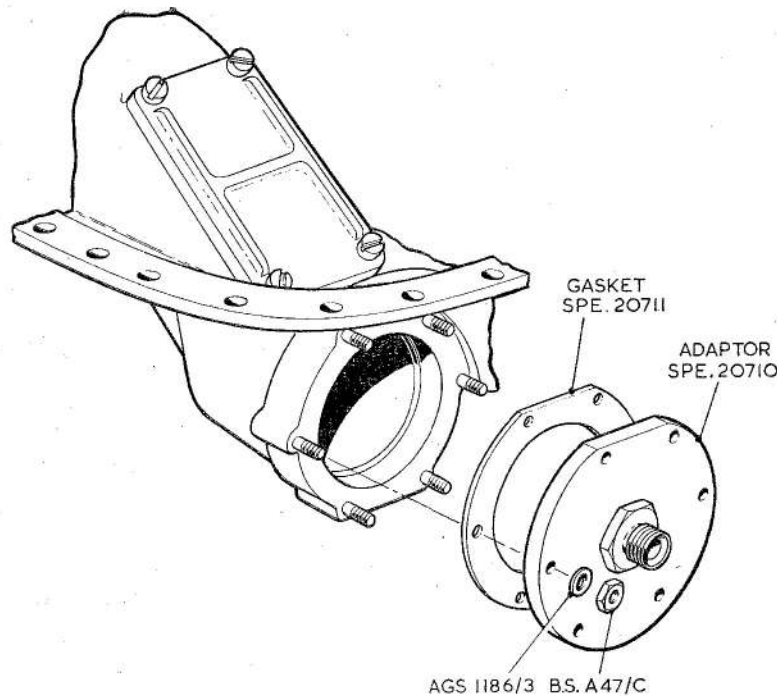

Fig. 12. Flap valve pressure test

Reverse flow leakage test

26. The flap valve in the mounting plate must now be tested for reverse flow leakage. Fuel at a pressure of 2 lb./in.² and 75 lb./in.² is to be applied through the adaptor SPE. 20710 (fig. 12) fitted to the outlet duct studs of the mounting plate. Fuel leakage past the valve should be collected in a measuring cylinder or other suitable graduated container and must not exceed a rate of 0.4 gal./hr. with fuel applied at 2 lb./in.² or 1.0 gal./hr. with fuel applied at 75 lb./in.² If leakage rates in excess of these figures are obtained, the valve plate should be removed and the seating re-lapped. Re-assemble and recheck.

Pump unit

Assembling the bellows gland (fig. 4 & 5)

27. (1) Smear the outside diameter of the bellows gland (81) with Celloseal and allow to stand for 30 minutes. Ensure that the Celloseal is confined to the outside diameter of the gland. Do not allow it to contaminate the convolutions, sealing surface, or the seal ring groove.

(2) Fit a new seal ring (48) in the groove in the bellows gland (81).

(3) Place the bellows unit on the spindle SPE.20695 (fig. 13). Ensure that the locking screw in the locating barrel SPE.20694 is clear of the bore. Place the barrel on the spindle, resting upon the gland. Tighten the locking screw permitting no movement of the assembly. Using a hand press and pump casting location tools illustrated in fig. 13, press the bellows gland into the pump casting (85). Tooling will correctly position the bellows gland to give correct gland loading on assembly.

Shaft component checking (fig. 4 & 5)

28. (1) Pre-select a bearing (43) that is a slide fit under thumb pressure both on the pump shaft (42) and in the upper bearing housing (44). Retain the shaft and the housing, and mark both so that they can be paired with the selected bearing and built into the same pump unit at a later assembly stage. Check that the selected bearing is

RESTRICTED

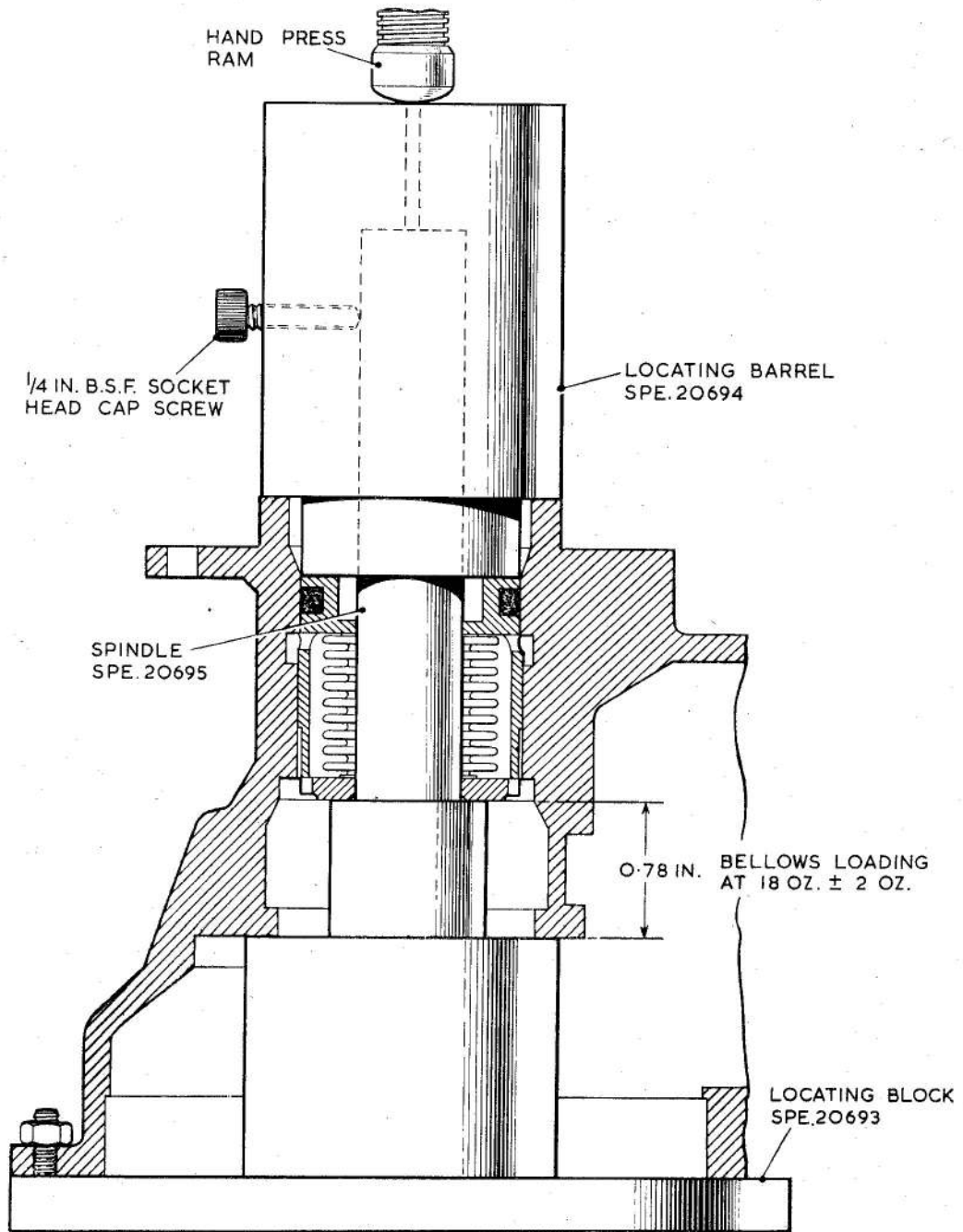

Fig. 13. Bellows gland assembly tools

~~RESTRICTED~~

smooth running with no roughness of the tracks when the inner race is rotated by hand.

(2) Check that the bearing housing (44) is perfectly clean and that the wall surface is smooth and free of score marks, burrs or adhering swarf. Insert the selected bearing. Assemble the retaining plate (37), securing it with six cheesehead screws (35) and shakeproof washers (36).

(3) Fit the bellows seal body assembly (82) (less the seal ring (46)), the bearing housing sub-assembly as detailed in para. 28(2) above and the thrower (38) to the selected shaft (42) and retain with the distance piece (39), shakeproof washer (40) and locknut (41). Fit the centrifugal impeller (53), helix (59) and lower bearing sleeve assembly (65) to the shaft in the correct assembly order and retain with the lock plate (61) and locknut (64). Inspect the fit of the components on the shaft, and ensure that all components will tighten flush against the shaft shoulders. Check concentricity of components on shaft with latter held between centres. Retain all the components for assembly into the same pump unit.

Refitting the volute assembly (fig. 1, 4 & 5)

29. (1) Coat the mating surfaces of the volute assembly (75) and pump body casting (85) with 'Celloseal' and allow to stand for 30 minutes.

(2) Secure the volute assembly (75) to the pump casting with five cheesehead screws (79) and self-locking nuts (80) and in one position with the cheesehead screw (50) and shakeproof washer (51). Tighten securely.

Note . . .

If the volute assembly was completely dismantled, re-assemble using the original paired upper and lower volute castings. Secure the castings with the thirteen screws ((157)—9 off: (154)—2 off: (149)—2 off) inserted from the top side and secure with the self-locking nuts (150). Replace any damaged studs (74) in the lower volute casting.

Assembling the upper bearing housing

30. (1) Remove the parts from the shaft (42) as assembled in para. 28. Retain all the components for assembly into the same pump unit.

(2) Fit a new seal ring (46) in the internal groove of the bellows seal body assembly (82). Smear the seal ring with Silicone MS.4 compound A.339, Ref. No. 33C/9424829.

(3) Position the bellows seal body over the upper end of the pump shaft (42) with the carbon insert facing downwards. Refit the bearing housing assembly (as para. 28), the thrower (38) and the special distance piece SPE. 16161 (39) and retain with the temporary shakeproof washer (40) and locknut (41).

Note . . .

If no spacer SPE.16161 is available, fit a scrap bevel gear (98B).

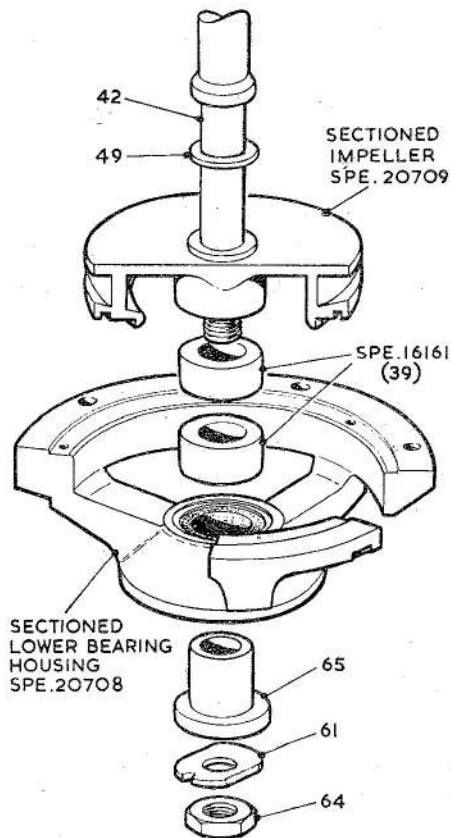

Fig. 14. Impeller clearance tools

~~RESTRICTED~~

Key to Fig. 14

35 CH. HD. SCREW	} RETAINING PLATE	61 LOCK PLATE	
36 SHAKEPROOF WASHER		SECURING	62 TAB WASHER
37 RETAINING PLATE	} TEMPORARY	63 LOWER BEARING COVER	
38 THROWER		PARTS	64 SPINDLE NUT, LOWER
39 DISTANCE PIECE		ONLY	65 LOWER BEARING SLEEVE
40 SHAKEPROOF WASHER			66 CIRCLIP
41 NUT		67 CH. HD. SCREW	} LOWER BEARING
42 PUMP SPINDLE		68 SHAKEPROOF WASHER	
43 BALL BEARING		69 DOWEL PIN	
44 UPPER BEARING HOUSING		70 SHIM	
45 GASKET		71 FILTER ASSEMBLY	
46 SEAL RING		72 VAPOUR GUIDE CONE	
48 SEAL RING		73 SELF-LOCKING NUT	
49 SHIM		74 STUD	
50 CH. HD. SCREW	} VOLUTE	75 VOLUTE CASTING	
51 SHAKEPROOF WASHER		SECURING	76 IMPELLER SHROUD PLATE
52 KEY		77 C'S'K. HD. SCREW	} IMPELLER SHROUD
53 IMPELLER		78 SELF-LOCKING NUT	
54 HELIX SHROUD		79 CH. HD. SCREW	} VOLUTE
55 SHIM		80 SELF-LOCKING NUT	
56 C'S'K. HD. SCREW	HELIX SHROUD SECURING	81 BELLOWS GLAND ASSEMBLY	
57 C'S'K. HD. SCREW	} VAPOUR GUIDE	82 BELLOWS SEAL BODY ASSEMBLY	
		CONE SECURING	83 RD. HD. SCREW
58 LOWER BEARING HOUSING		84 SHAKEPROOF WASHER	HOUSING SECURING
59 HELIX		85 PUMP BODY CASTING ASSEMBLY	
60 CARBON BEARING			

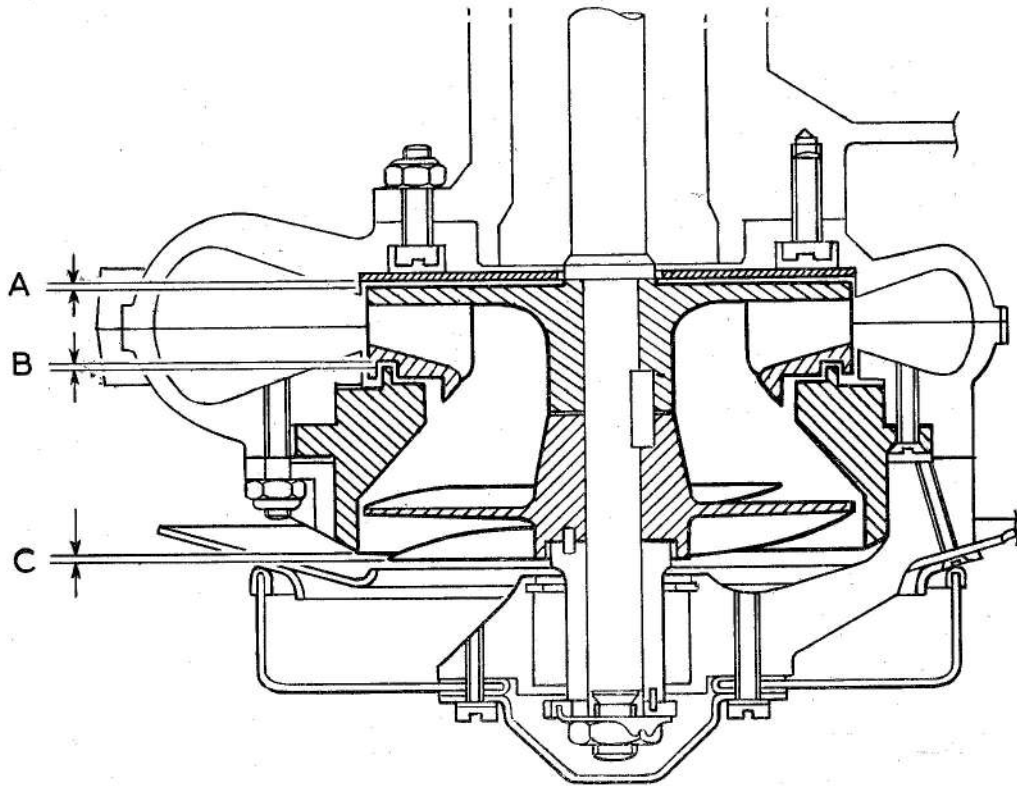

Fig. 15. Impeller, helix shroud and helix assembly clearances

RESTRICTED

RESTRICTED

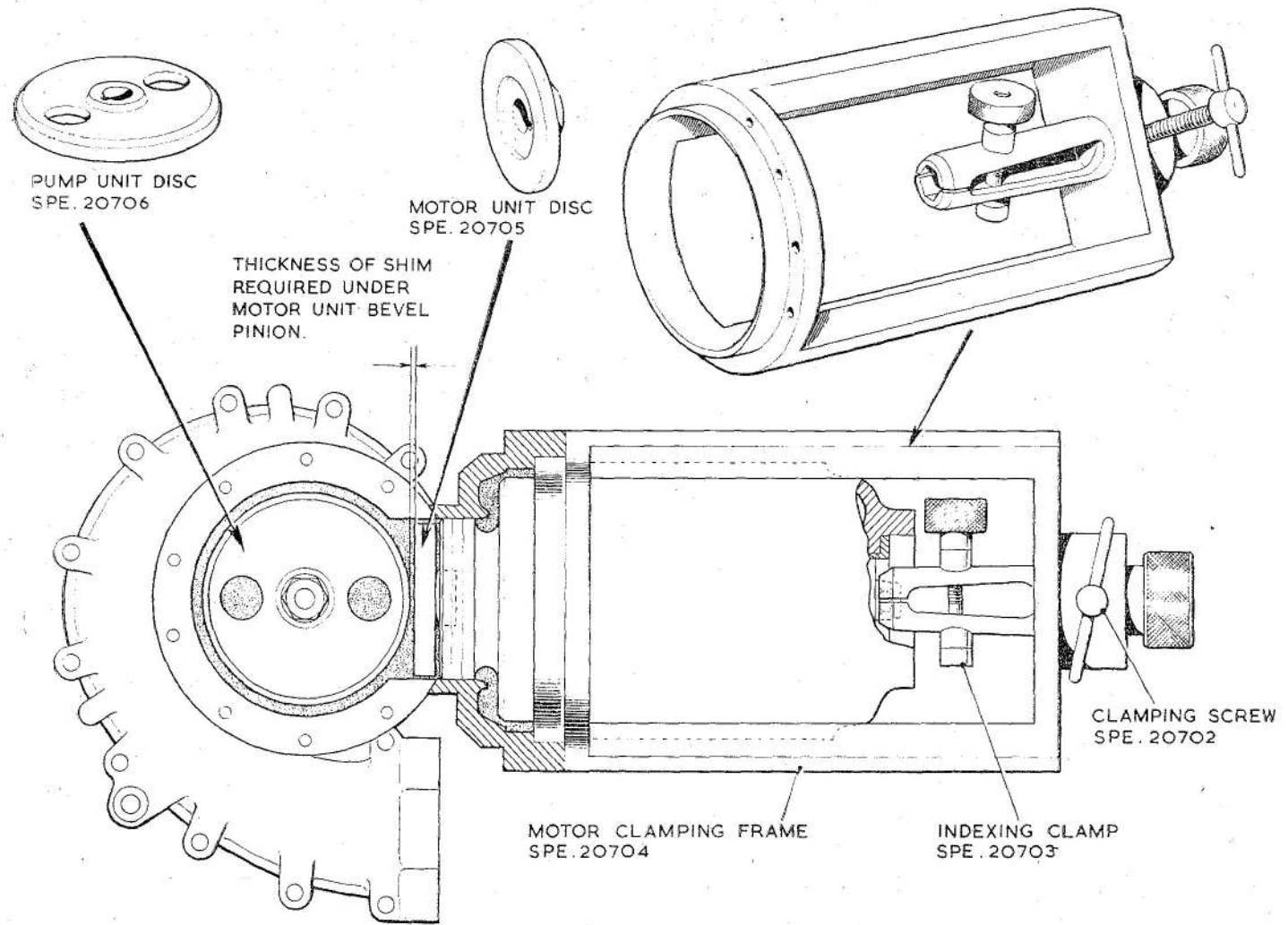

Fig. 16. Bevel pinion shimming

(4) Coat the mating surfaces of the bearing housing (44), the pump body casting (85) and both sides of the gasket (45) with Celloseal and allow to dry for half an hour.

(5) Position the gasket (45), insert the pump shaft carefully through the bellows gland and align the fixing holes in the bearing housing flange with those in the pump body casting. Secure with the five round head screws (83) and shakeproof washers (84).

Assembling the centrifugal and helical impellers (fig. 4 & 5)

31. (1) Refit the impeller shroud plate (76) and secure with the five countersunk head screws (77) and self-locking nuts (78).

(2) Fit shims (49) over the pump shaft of greater total thickness than that required to set the gap between the centrifugal impeller (53) and the shroud plate (76) at the required 0.010 in./0.020 in. (dim. A, fig. 15).

(3) Fit the special cut-away impeller SPE.20709 (fig. 14) over the pump shaft together with two distance pieces SPE.16161 (39). Temporarily secure the sectioned carbon bearing housing SPE.20708 (fig. 14) to the volute studs in three equi-spaced positions only with self-locking nuts (73). Fit the lower bearing sleeve (65) small diameter end first over the pump shaft and secure with a locknut (64).

(4) Using right-angled feeler gauges check the gap between the impeller SPE.20709 and the impeller shroud plate (76) at several radial positions. Remove the carbon bearing housing, spacers and impeller to increase or decrease the thickness of shim (49) fitted and bring the gap within the specified 0.010 in./0.020 in.

(5) Position the impeller (53) on the shaft. Fit helix shroud spacing shims (55) of greater thickness (0.030 in./0.040 in.) than that likely to be finally required and secure the helix shroud (54) in three equi-spaced positions with countersunk head screws (56). Fit spac-

ing bushes SPE.16161, the lower bearing sleeve (65) and secure with a locknut (64). Remove the shims (55) progressively until the impeller shroud just impedes turning of the impeller by hand, replacing the shaft components after each alteration of the shim thickness. Release the locknut (64), remove the lower bearing sleeve and replace after securing the sectioned carbon bearing housing SPE.20708 (fig. 14) to centralise the pump shaft. Recheck that the helix shroud just impedes turning of the impeller by hand.

(6) Remove the shaft components and add shims (55) with a total thickness of between 0.005 in. and 0.010 in. (dim. B, fig. 15) to those already fitted. Refit the helix shroud (54) and secure with the six countersunk head screws (56).

(7) Fit the helix (59) together with any shims (70) necessary to ensure that its blades project 0.04 in./0.06 in. (dim. C, fig. 15) below the rim of the helix shroud (54) when the shaft components are tightened down. When the correct thickness of shim has been determined, remove the helix and key the centrifugal impeller (53) to the shaft with the drive key (52). Replace the shims (70) and the helix (59).

Assembling the carbon bearing housing and vapour guide cone (fig. 4 & 5)

32. (1) If the carbon bearing (60) was removed from its housing (58) during dismantling, a new bearing must be pressed into position with a suitable drift and the bore reamed to 15.875 mm. (+0.05 mm., -0.03 mm.). The bore of this bearing must be concentric with the bore of the housing locating the helix shroud to within 0.03 mm. total indicator reading. Retain the bearing with the circlip (66).

(2) Position the lower bearing sleeve assembly ((65) and (69)—2 off) over the pump shaft, flanged end first. Locate the dowel pin (69) in the location hole drilled in the end face of the helix (59).

(3) Secure the carbon bearing housing assembly to the studs of the volute

RESTRICTED

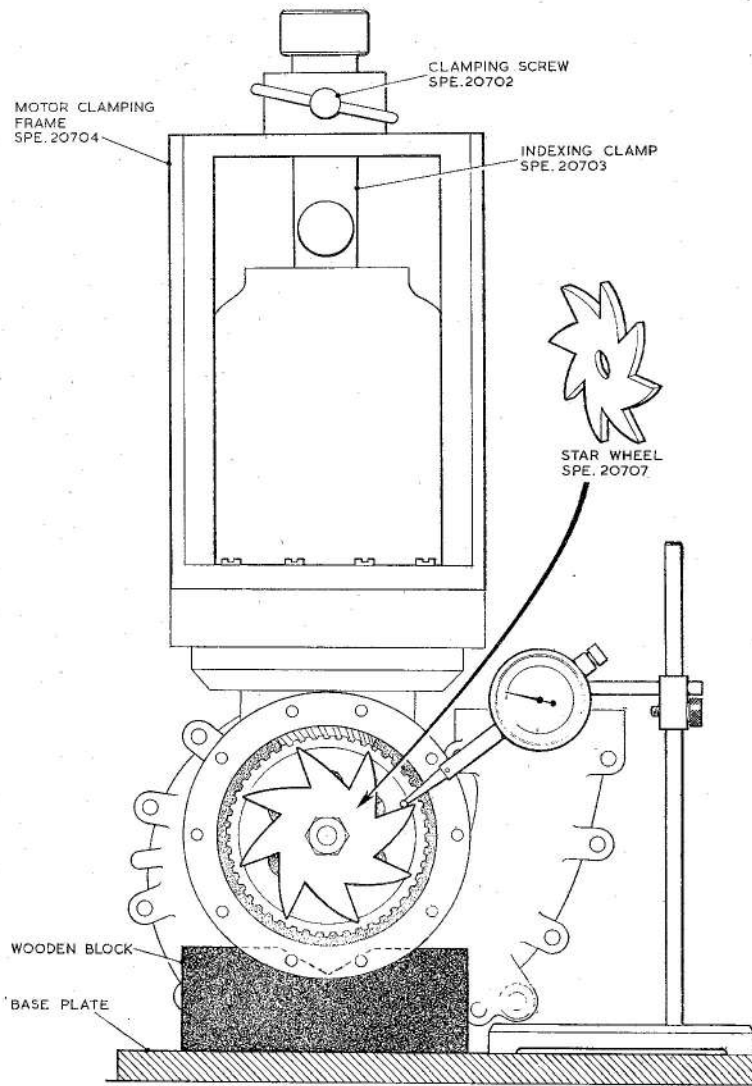

Fig. 17. Backlash checking

assembly (75) with the six self-locking nuts (73). Tighten diagonally opposite nuts in turn by degrees.

(4) Fit the lock plate (61) against the end face of the lower bearing sleeve (65), locating the dowel (69) in the plate. Fit the tab washer (62) and secure the shaft components with the locknut (64). When securely tightened, bend the washer tabs upwards against the flats of the nut.

(5) Refit the vapour guide cone

assembly (72) to the carbon bearing housing (58) with three countersunk head screws (57). Peen metal into the slots of these screws to lock them.

Completing the assembly of the pump unit (fig. 1, 4 & 5)

33. (1) Position the inlet filter (71) and the lower bearing cover (63) on the carbon bearing housing (58) and secure both in position with the four cheese-head screws (67) and shakeproof washers (68),

RESTRICTED

(2) Prepare the gland drain pipe gaskets (159) by pre-compressing under a hand press. Smear Wellseal jointing compound on the mating faces of the pump body casting (85) and the gland drain pipe (158) flanges. Fit the gaskets and the pipe to the pump casting with three cheesehead screws (160) and shakeproof washers (161) at each flange.

(3) This completes the reassembly of the pump unit and if assembly of the complete unit is not to be proceeded with immediately it should be kept in a polythene bag to prevent ingress of dirt and foreign matter.

Fitting the motor unit to the pump unit

Bevel pinion shimming (fig. 1, 4, 5, 8 & 9)

34. (1) Before completing the motor unit assembly it is necessary to determine the thickness of the shim (104) required to position the bevel pinion and obtain correct meshing with the pump shaft gear. Proceed as follows:

(a) Remove the locknut (41) and washer (40) securing the spacer or bevel gear to the pump shaft. If a gear is fitted, use the extractor SPE.20689 to assist removal. Fit the special disc SPE.20706 (fig. 16) to the pump shaft and secure.

(b) Remove the distance piece or the bevel pinion fitted to the motor unit. Fit the special disc SPE.20705 (fig. 16) to the rotor shaft and secure.

(c) Locate the motor unit in the recessed housing of the pump casting and secure in position with the special clamping frame SPE.20704 (fig. 16). Use 4 B.A. bolts and nuts in four positions only to securely clamp the motor unit in position.

(d) With feeler gauges measure the gap between the outer edge of the pump shaft disc and the front face of the motor spindle disc (fig. 16). This is the thickness of shim (104) required for assembly under the motor unit pinion to give correct meshing of the pinion with the pump shaft gear wheel.

(e) Separate the motor unit from the pump unit by removing the clamping frame, and remove the disc. Select shims (104) of correct total thickness and check that they are free of edge burrs. With the driving key (99) in position, press on the bevel pinion (98B). Note that this pinion is marked so that it can be easily paired with the matched pump shaft gear as supplied. Secure the pinion with the clamp washer (163) and self-locking nut (162). Tighten. Fit a new joint ring (103) in the groove in the lower motor case.

(f) Inspect the motor unit for cleanliness, tightness of all screws (c/sk. head screws should be locked by peening metal into their slots) and the condition of the three electrical supply leads. The rotor shaft thread should protrude through the nut securing the pinion. Check that the motor unit turns freely with no indication of sticking.

Note . . .

Paragraphs (g) and (h) assume that a paired gear assembly with known backlash characteristics is being fitted. Unpaired gears will not be engraved with meshing points.

(g) Remove the pump shaft disc and fit an excess number of shims (94), the bevel gear key (95) and the bevel gear (98A). Place the special starwheel SPE.20707 (fig. 17) on top of the gear and align it so that one arm is between the markings X—X which will be found engraved on two adjacent gear teeth. Secure the starwheel with a $\frac{3}{8}$ in. B.S.F. nut.

(h) Lubricate the motor unit seal ring (103) with a smear of Silicone MS.4 compound A.339, Ref. No. 33C/9424829. Ease the complete motor unit assembly into the pump unit casting, threading the supply leads through the conduit cast. If a paired gear and pinion are being fitted, align them so that the pinion tooth marked X is meshed between the two gear teeth similarly engraved

RESTRICTED

X. This alignment is important. Locate the motor unit by registering the dowel pin (3) in the pump casing location hole. Hold in position.

Gear alignment (fig. 1 & 4)

35. (1) Fit the frame SPE.20704 over the motor unit and secure it to the pump casting in four positions. Apply 200V, 400 c.p.s., 3 ph. A.C. supply to the motor unit for a few seconds to check that all parts are free running. Clamp the motor spindle end nut in the indexing clamp SPE.20703. If unpaired gears are being fitted, set the gears so that one arm of the starwheel is in line with the motor centre-line and secure the indexing clamp. Mark the

meshing gear and pinion teeth so that the starting point for the backlash check can be determined.

(2) Take up the backlash between the gears and note whether the reading on the angular contact clock gauge graduated in 0.0005 in. indicates that it is (a) within limits 0.002 in./0.006 in. or (b) in accordance with the first backlash figure quoted on the label supplied with the paired gears under check. The ball of the clock gauge should be located on the flat portion of the star point at a position close to its end. If the reading is outside the limits, remove the starwheel, withdraw the bevel gear using the extractor tool SPE.20689 (fig. 6) and reduce the thick-

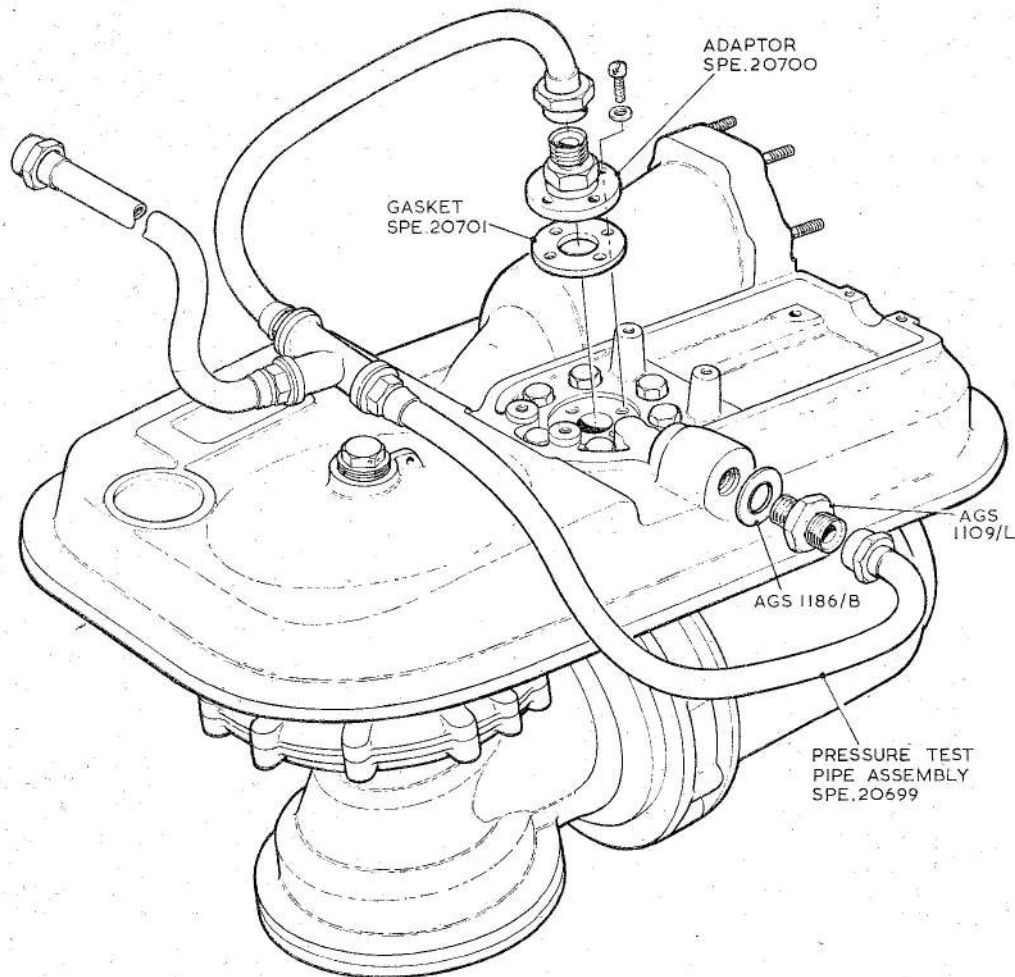

Fig. 18. Pump pressure testing

RESTRICTED

ness of the shims (94) fitted. Re-assemble and align the gear and starwheel. Re-check the backlash, and continue to reduce the shim thickness until the reading on the clock gauge indicates that the backlash at the starting point is (a) within the specified limits or (b), when figures are available, in accordance with the first figure on the label for the pair of gears being assembled.

(3) Rotate the starwheel through 360 degrees (1 revolution) in a clockwise direction and re-check. The backlash must be within 0.002 in. of the reading at the initial checkpoint and within the range 0.005 in./0.009 in. Adjust the shims (94) if the tolerance is outside this limit and range and re-check backlash at the initial and second positions. Repeat the check twice more after further complete revolutions of the gear wheel in a clockwise direction.

(4) Rotate the gearwheel through 45 degrees ($\frac{1}{4}$ revolution) in a clockwise direction and check and record the backlash. Repeat this seven more times, checking the backlash after each movement of the gear. The backlash figures at all positions of the check must be within 0.002 in. of one another and within the range 0.005 in./0.009 in. Any adjustment of the shimming necessitates a recheck of the backlash figures at all previously completed check points.

(5) Remove the starwheel from the pump gear shaft, and refit the tab washer (96) and the locknut (97). Hold the gearwheel with the special key SPE.20691 (fig. 6) and securely tighten the nut with a box spanner. Bend the washer tabs upwards against the flats of the nut. Remove the pump from the fixture, taking care to hold the motor unit in position.

Securing the motor unit (fig. 1 & 4)

36. (1) Fit a new sealing ring (105) in the recess between the motor unit and the pump casting. Clamp the motor unit in position with the ring (106), securing it with the ten cheesehead screws (107) and self-locking nuts (108) and in the two lower positions with the cheese-

head screws (110) and shakeproof washers (111). Tighten diagonally opposite nuts in turn by degrees to ensure even compression of the seal ring.

Assembling the gear box (fig. 1 & 4)

37. (1) Fill the gear box with 30 cc. (+10%; - nil) of grease ZX-26 (Ref. No. 34B/9426549).

(2) Degrease the pump casing flange, taking care not to let the solvent get into the grease.

(3) Fit a new seal ring (100) in the seating in the gear box cover (91). Smear the seal ring with Silicone MS.4 compound A.339, Ref. No. 33C/9424829 and secure the cover to the pump casting with eight cheesehead screws (92) and self-locking nuts (93) and in two positions with the cheesehead screws (101) and shakeproof washers (102).

Assembling the mounting plate to the pump unit assembly (fig. 1, 2, 3 & 4)

38. (1) Fit new seal rings (172) to the coupling sleeve (171) and smear with Silicone MS.4 compound. Insert one end of this sleeve into the outlet of the volute assembly (75).

(2) Smear new seal rings (140) and (145) with Silicon MS.4 compound and position in the grooves in the mounting plate embossment of the pump casting. Position the mounting plate assembly (as para. 25) locating the three supporting studs (181 and 120) and secure with the six drilled hexagon-head bolts (143) and seal washers (144). Wire lock all the bolt heads together in accordance with accepted practice using a 22 S.W.G. non-corrodible steel locking wire.

- (3) Adjust the larger support stud (181) as follows:

(a) Fit the self-locking nut (170) to the stud. Screw this nut down until it just touches the volute casting. Do not overtighten as this may cause distortion at the seal rings (140 and 145).

RESTRICTED

- (b) Tighten the nut (180) against the underside of the volute.
 - (c) Tighten the locknut (182) against the nut (180).
 - (d) Finally tighten the second nut (180) against the mounting plate.
- (4) Adjust the smaller studs (120) supporting the motor unit as follows:
- (a) Adjust the locknut (122) and shakeproof washer (123) until they just touch the underside of the support bracket (15).
 - (b) Fit a self-locking nut (121) to each stud and tighten onto the support bracket.

Pressure testing the pump assembly

39. (1) Tuck the motor supply leads into the pump base casting and fit the adapter SPE.20700 and gasket SPE.20701 (fig. 18) to the casting with four 6 B.A. cheesehead screws. Connect up the pipe assembly SPE.20699 to this adapter and to the gland drain exit as illustrated in fig. 18.

(2) Gradually increase the applied air pressure through the pipe assembly from zero to 10 lb./in.² and maintain the pressure for 5 minutes. Immerse the pump in a small tank of Kerosine fuel. Air bubbles at any point will indicate a leakage past the seals or gland. A leakage past the gland only is permissible provided the pump satisfactorily complies with para. 48(2). No other leakage is permissible. If leakage is evident the faulty seal must be dismantled and replaced after drying the affected surfaces. Re-assemble and re-check. When satisfactory, remove the pressure test components and dry off the terminal box housing with compressed air.

Assembling the terminal block and electrical connection (fig. 1 & 2)

40. (1) Refit the three grommets (112) in the fireproof motor breather (146), thread one motor supply lead through each grommet and secure the breather plate (146) and breather packing (113) to the casting with the four cheesehead screws (147) and shakeproof washers (148).

(2) Check that the clinch nuts of the terminal board mounting plate sub-assembly (117) are secure.

(3) Fit the three terminal screws (136) in the terminal block (138) and secure with three shakeproof washers (119) and nuts (137).

(4) Secure the terminal block through the terminal base cover (139) to the mounting plate (117) with three countersunk-head screws (165) and self-locking nuts (116).

(5) Secure the cable clamps (115) with two cheesehead screws (114) each, into the clinch nuts of the terminal block mounting plate.

(6) Secure the terminal block plate (117) to the pump mounting plate (156) with four cheesehead screws (118) and shakeproof washers (119).

(7) Replace any damaged leads to the electrical connection pins. Leads should be approximately 5½ in. long. (Unipren 6 cable) and soldered to the pins.

(8) Cover the three soldered joints with rubber sleeves (129). Fit a 4 B.A. terminal tag (135) to the end of each lead.

41. (1) Secure the electrical connection (128) to the mounting plate (156) in two positions with the cheesehead screws (125) and shakeproof washers (126). Note that the plug should be fitted with the larger diameter location pin at the lowest point when the pump is in the installation position.

(2) Solder 4-B.A. terminal tags (135) to each of the three motor unit leads.

(3) Connect the motor supply leads and the electrical connection leads to the terminal block, ensuring that the two leads connected to each terminal are fitted with the same phase number identification sleeves (131). Secure with the three nuts (137) and shakeproof washers (119).

(4) Trap the leads to the motor unit and the electrical connection under the cable clamps (115).

~~RESTRICTED~~

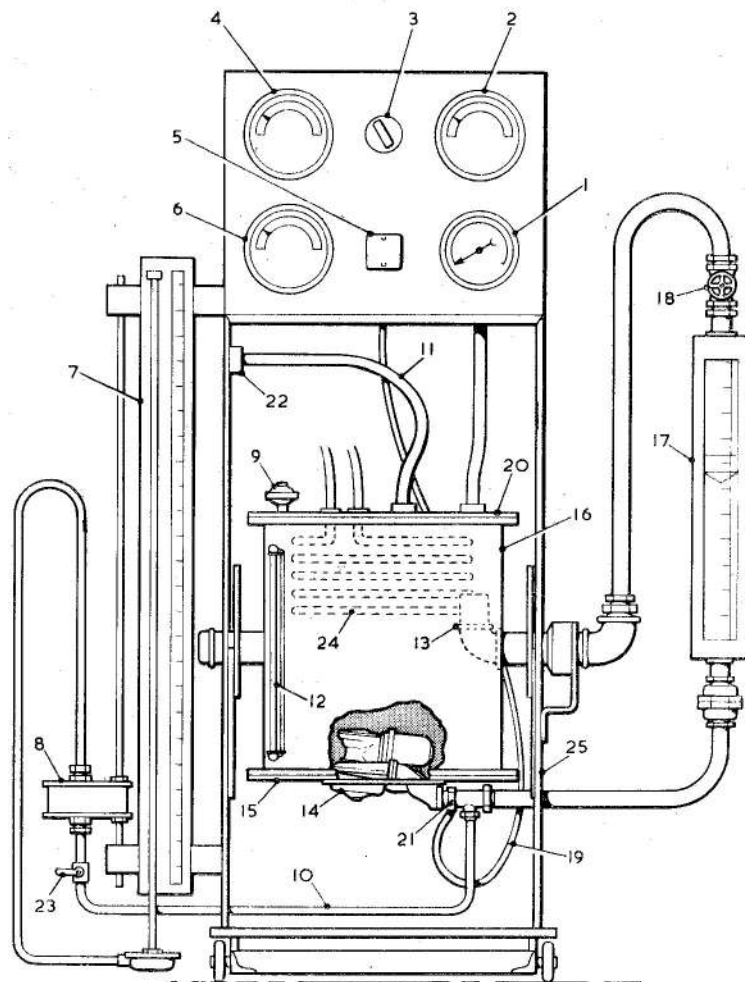

- 1 AIR PRESSURE GAUGE (0-15 P.S.I.)
- 2 FREQUENCY METER (400 c.s.)
- 3 ROTARY SWITCH
- 4 VOLTMETER (0-250V A.C.)
- 5 FUSE HOLDER
- 6 AMMETER (0-5A)
- 7 MERCURY MANOMETER
- 8 FUEL/AIR BOTTLE
- 9 AIR RELIEF VALVE
- 10 PRESSURE TAPPING FROM PUMP
- 11 AIR LINE TO TANK
- 12 FUEL LEVEL SIGHT GLASS
- 13 FUEL FILTER
- 14 FUEL PUMP ON TEST

- 15 TANK BOTTOM END PLATE FOR
SPE 3536 PUMPS
- 16 FUEL TANK
- 17 FLOWMETER
- 18 FLOW REGULATING VALVE
- 19 ELECTRICAL SUPPLY TO PUMP
- 20 TANK TOP END PLATE FOR
SPE. 3536 PUMPS
- 21 MANOMETER PRESSURE CONNECTOR
- 22 AIR PRESSURE REDUCING VALVE
- 23 PRESSURE TAPPING ON-OFF COCK
- 24 WATER COOLING COIL
- 25 TRUNNION FRAME

Fig. 19. Test rig

RESTRICTED

(5) Refit the terminal box cover assembly (132) and secure with four 6-B.A. cheesehead screws (141) and shakeproof washers (142) and with two 4-B.A. cheesehead screws (130) and shakeproof washers (126).

(6) Secure the electrical connection (128) with a further two screws (125) and shakeproof washers (126) to the terminal box cover (132).

(7) Refit the quick-release connection clamp (127) to the electrical connection.

Testing and wirelocking

42. (1) The pump is now ready for testing in accordance with the Schedule of Tests (para. 46-52). After satisfactory completion of these tests the pump is to be wirelocked at the following positions.

(a) Between terminal box cover retaining screws.

(b) At the drain plug (wirelock to the drilled web of the mounting plate).

(c) Between the gear box cover (91) and the motor clamp ring.

(d) Between the gear box cover and the pump body casting.

Repair workshops should use their own seals for this purpose.

TESTING

General

43. The complete pump must be tested in accordance with the Schedule of Tests detailed in para. 46-52. The pump must be rejected if it fails to comply with these tests.

Test equipment

44. A diagrammatic arrangement of a suitable test rig for SPE.3536 fuel pumps is illustrated in fig. 19. Alternatively use a universal fuel pump test rig if available. Use AVTUR fuel for all tests, maintaining temperature at between 15°C and 25°C.

Preparation

45. Check cleanliness of pump and examine the seal ring in the peripheral groove

of the mounting plate. Bolt the pump to the tank mounting plate. Delivery line and electrical supply connections are made to the pump mounting plate and are outside the test tank.

SCHEDULE OF TESTS

Insulation resistance test

46. The insulation resistance is to be measured at the following times:—

(1) The motor unit only after speed checking.

(2) The complete pump before the gland leakage test (para. 48) and after completing the endurance test (para. 51).

All the above tests must be carried out while the motor unit is warm, using a 500 volt constant pressure insulation resistance tester. The insulation resistance must at no time be less than 2 megohms (10 megohms for para. 46(1)).

Motor speed checking

47. The motor speed and current consumption at 200 volts, 400 c/s, must be measured and recorded when the motor unit is subjected to a torque of 122 oz.in. applied by means of the calibrated fan SPE.17408 (fig. 6) or a suitable dynamometer. With the motor unit at normal running temperature the motor speed must be 7050 ± 100 r.p.m. and current consumption must not exceed 4.25 amps.

Gland leakage tests

48. (1) With the flow regulating valve closed and the pump fully submerged under a 12 in. head of fuel, superimpose air pressure over the fuel at 15 lb./in.² Run the pump for 15 minutes under these conditions on an input voltage of 200 volts a.c., 400 c/s. During the running of the pump, and also when stationary, observe for:—

(a) External leakage of fuel.

(b) Internal leakage of fuel.

(c) Gland leakage.

(2) The allowable rate of leakage past the gland is 2 cc. per hour with the pump running, and 1 cc. per hour when stationary. No other leakage is permissible.

RESTRICTED

Starting test

49. With the pump fully submerged in fuel and the supply voltage adjusted to 194 volts a.c. 392 c/s, operate the pump by switching on the supply. The pump must start satisfactorily. Repeat the check 10 times. The pump must start immediately on each check.

Dry test

50. Mount the pump clear of fuel and run it dry for 5 minutes on an applied voltage of 250V, 408 c/s. The current consumption during this test must not exceed 2.5 amp.

Endurance test

51. With a 6 in. head of fuel over the pump inlet, run the pump for 1 hour on a supply voltage of 200 volts a.c., 400 c/s at a flow rate of 3500 gal./hr. The delivery pressure and the current consumption are to be recorded at the beginning and end of the test and must be within the following limits:—

200 volts, 400 c/s: 3500 gal./hr.: 11 lb./in.² min.: 4.25 amp. max.

Any appreciable change in performance other than that resultant from the initial warming up will reject the pump.

Calibration test

52. With a 6 in. head of fuel over the pump inlet, adjust the flow regulating valve to obtain flows of from 0 to 4500 gal./hr. in steps of 500 gal./hr. Record the delivery pressure and motor current at each flow stage with the pump running on an applied voltage of 200 volts, 400 c/s. Check for conformity with the acceptance performance of the pump detailed below:

0 gal./hr.: 19.5 lb./in.² maximum, measured at the pump outlet.

3500 gal./hr.: 11.0 lb./in.² minimum: 4.25 amps. maximum.

RESTRICTED

TABLE 4

Faults, possible causes and remedies

Fault	Possible cause	Remedy
Gland leakage	(a) Bad finish between gland seal faces.	Dismantle pump unit. Relap gland seal faces. If excessively worn renew gland.
	(b) Cracked carbon.	Renew bellows seal body assembly.
	(c) Insufficient pressure between gland seal faces.	Re-position gland in pump body casting.
Excessive current consumption	(a) Faulty motor unit.	Check the condition of the motor unit. Refer to Table 2.
	(b) Excessive loading on gland.	Re-position gland in pump body casting.
	(c) Fouling of impeller by foreign matter.	Remove inlet filter and examine. Clean as necessary.
	(d) Faulty bearings (indicated by pump being stiff to turn or an intermittent jerky resistance is felt when pump shaft is rotated).	Check that pump and motor bearings are free turning. Dismantle pump and renew as necessary.
Excessive current consumption but rotor free to turn and pump will not start	(a) Faulty coils.	Remove motor unit from pump unit. Check coils for continuity.
Very high current consumption	(a) Short circuit.	Check insulation resistance between one pole and motor frame. Check leads for damaged insulation etc.
Low or fluctuating current	(a) Faulty motor unit.	Check condition of motor unit. Refer to Table 2.
Low delivery pressure	(a) Faulty motor unit.	Check motor speed.
	(b) Impeller impedance.	Check for obstruction. Check clearances. Refer to Table 3.
Pressure surge	(a) Tight or pre-loaded bearings.	Check fits, ease or replace as necessary.
	(b) Excessive loading on pump gland.	Correctly position gland in pump body casting.
Low insulation resistance	(a) Dampness in motor windings.	Prolonged drying of field at 93°C. Refer to Table 2.

RESTRICTED

This file was downloaded from the RTFM Library.

Link: www.scottbouch.com/rtfm

Please see site for usage terms, and more aircraft documents.



Instrument panel from a MiG-21 (XP558)