

Cancelled now obsolete

A2/142

F.S./1

A.P.4343D, Vol. 6, Book 2, Sect. 8, Chap. 6A
A.L.118, July 63

do not destroy

Chapter 6A

PUMP, FUEL, SPE.1207, Mk. 2

LIST OF CONTENTS

	Para.		Para.
<i>Introduction</i>	1	Assembling	
Reconditioning		<i>Pump unit</i>	
<i>Tools and test equipment</i>	2	<i>Reaming the carbon bearing</i>	8
Dismantling		<i>Assembling the bellows unit</i>	9
<i>Separating the pump unit from the sump mounting plate</i>	3	<i>Fitting the bellows unit into the pump casing</i>	10
<i>Dismantling the mounting plate</i>	4	<i>Assembling the volute casing</i>	11
<i>Dismantling the pump unit</i>		<i>Assembling the by-pass valve and delivery outlet</i>	12
<i>Detaching and dismantling the outlet connector</i>	5	<i>Fitting the motor unit to the pump unit</i> ...	13
<i>Detaching the volute assembly</i>	6	<i>Attaching the suppressor housing cover and electrical connection blanking plate</i> ...	14
<i>Removing the bellows unit assembly</i> ...	7	<i>Pressure testing the pump assembly</i>	15
		<i>Assembling the inclined sump mounting plate</i>	16
		Testing	18

LIST OF ILLUSTRATIONS

	Fig.		Fig.
<i>Fig. 1 to 14 appear in Chap. 6</i>		<i>Assembly of bellows gland to housing</i> ...	20
<i>Sectional view of pump/motor assembly</i>	15	<i>Gland housing sub-assembly, pressure test fixture</i>	21
<i>Part sectional view of pump/motor assembly</i>	16	<i>Bellows gland housing assembly to pump casing</i>	22
<i>Exploded view of mounting plate and outlet connector</i>	17	<i>Bellows gland lubrication hole drilling</i> ...	23
<i>Bellows housing removal</i>	18	<i>Motor lead positioning</i>	24
<i>Bellows gland removal from housing</i> ...	19	<i>Pressure test tools</i>	25

LIST OF APPENDICES

	App.
<i>Pump, Fuel, SPE.1207, Mk. 1</i>	1

~~RESTRICTED~~

Introduction

1. This chapter details the differences in the dismantling and assembling procedure for SPE.1207 fuel pumps as compared to the basic chapter on the SPE.1200 series pumps. Generally, all the information given in the basic chapter will apply to the SPE.1207 pumps and only information which is not contained in the basic chapter will be given in this chapter. Illustration references used in this chapter are consecutive to the figure references used in the basic chapter, so that reference can be made to illustrations in either chapter.

RECONDITIONING

Tools and test equipment

2. In addition to the special tools listed under Table 1 of the basic chapter, the following tools are required for use on SPE.1207 fuel pumps.

DISMANTLING

Separating the pump unit from the sump mounting plate (fig. 17)

3. (1) Remove the four screws (81) and shakeproof washers (82) securing the electrical connections to the mounting plate (25). Release the plug pins from the connection moulding.
- (2) Remove the self-locking nuts (19), the two socket headed screws (39) and shakeproof washers (40), then remove the three bolts (30) with Seloc washers (31) to separate the pump unit from the mounting plate.

Dismantling the mounting plate

4. (1) Remove the four screws (206) and detach the water drain valve (205); collect the seal washer (207).
- (2) Remove the three round-head screws (85) and shakeproof washers (86) to detach the motor breather cover assembly (84).
- (3) Straighten the tab washer (43) and remove the gland drain (44).
- (4) Remove the two screws (185) and spring washers (186) and withdraw the inspection plate (187).
- (5) Extract the seal ring (21) from the flange groove of the mounting plate; this seal ring must be renewed during reconditioning.

Dismantling the pump unit

Detaching and dismantling the outlet connector (fig. 17)

5. Separate the motor and pump unit, using the procedure detailed in the basic chapter, then commence to dismantle the pump unit as follows:—
- (1) Remove the four self-locking nuts (41) and screws (42) securing the outlet assembly to the volute assembly.
- (2) Separate the by-pass valve assembly from the outlet casting (74) by removing the six screws (101).

TABLE 1
Special tools and equipment for SPE.1207 fuel pumps

Nomenclature		Part No.	Fig. No.
Drift	} Bellows housing removal	SPE.17380	} 18
Register			
Guide bush			
Guide bush.	Bellows gland removal	SPE.19492	19
Location block,	bellows gland assembly	SPE.19493	21
Punch,	bellows gland and housing assembly	SPE.17382	21, 23
Pressure test fixture,	gland housing	SPE.19518	22
Register,	bellows housing assembly	SPE.17383	23
Blanking plate and lead housing	} Pressure test	SPE.17402	} 25
Gasket			

~~RESTRICTED~~

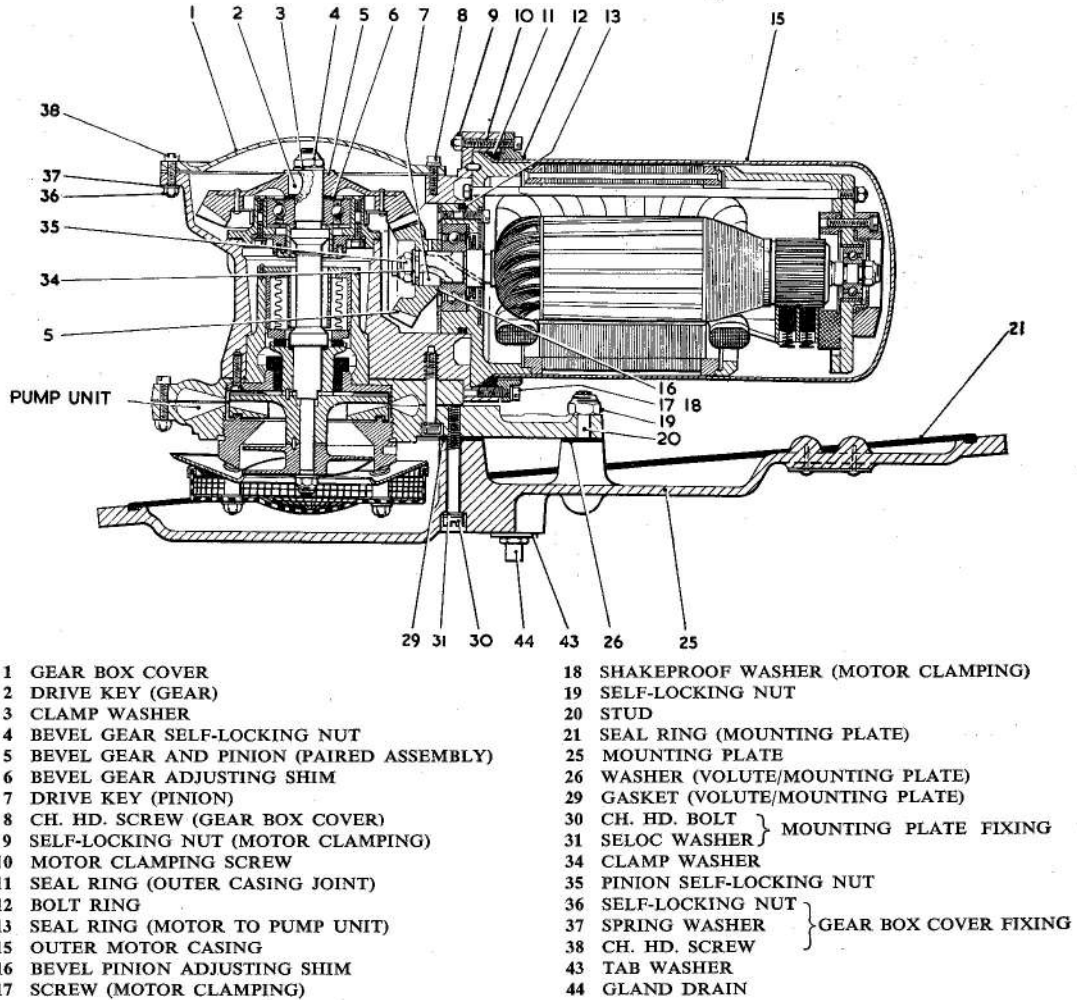

Fig. 15. Sectional view of pump/motor assembly

(3) Examine the flap valve, valve seating and by-pass filter. Do not dismantle the valve, if these parts are undamaged. If the parts are damaged, remove the two countersunk screws (189) securing the hinge plate (197), and withdraw the pin (198) to remove the flap valve. Remove the circlip (188) and extract the filter assembly (66).

(4) Remove the inlet filter and the impellers (basic chap, para. 6).

Detaching the volute assembly (fig. 1)

6. (1) Remove the five screws (146) securing the lower bearing housing (136) through the volute assembly (410) to the pump

body, and extract the housing assembly. Remove the three socket screws (121) and shakeproof washers (122) securing the volute assembly to the pump casting. Break the joint between the two parts and remove the volute assembly.

Note . . .

No attempt should be made to remove the carbon bearing from its housing.

- (2) If the seal between the two halves of the volute assembly is faulty, dismantle the assembly by removing the seven self-locking nuts (141), withdrawing the screws (145) and separating the two halves (142 and 144).

RESTRICTED

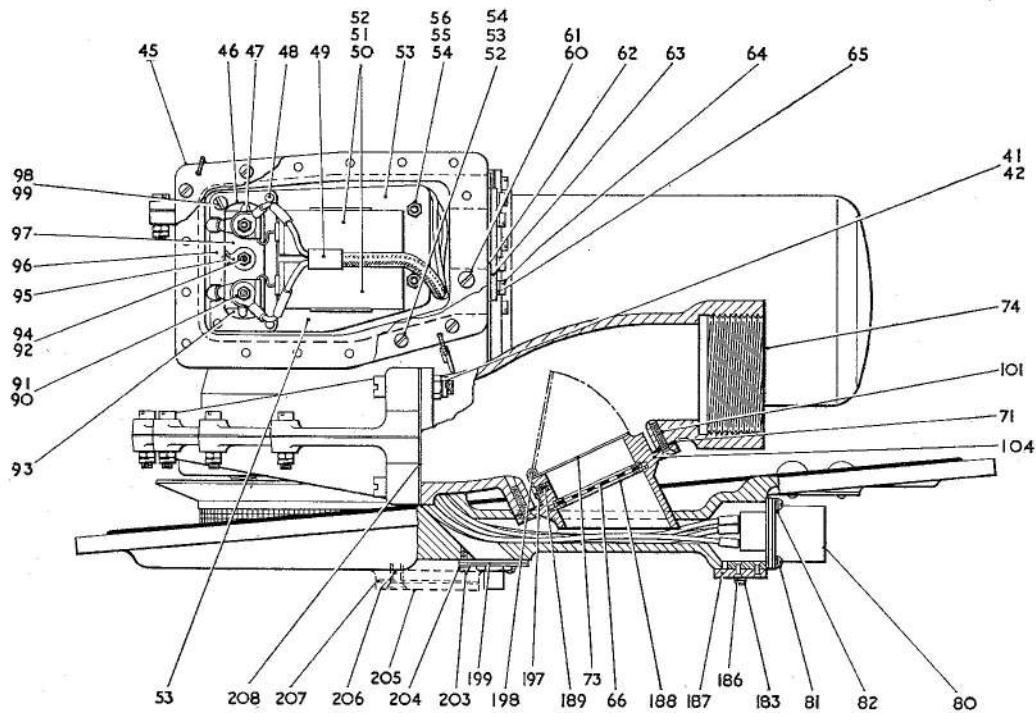

- | | | | |
|-----------------------------------|----------------------------------|--|---|
| 41 SELF-LOCKING NUT | } OUTLET/VOLUTE FIXING | 90 PLAIN WASHER | } TERMINAL ASSEMBLIES |
| 42 CH. HD. SCREW | | 91 SHAKEPROOF WASHER | |
| 45 CAPACITOR COVER ASSEMBLY | | 92 LOCKNUT | |
| 46 CONDENSER RETAINER BAND | | 93 CONDENSER ASSEMBLY | |
| 47 CAPACITOR TAG | | 94 CH. HD. SCREW (TERMINAL BLOCK FIXING) | |
| 48 RIVET (PANEL ASSEMBLY) | | 95 EARTHING TAG (CABLE SHIELD) | |
| 49 ELECTRICAL LEAD ASSEMBLY | | 96 INSULATION PLATE | |
| 50 CAPACITOR | | 97 TERMINAL BLOCK (INCLUDING TERMINALS) | |
| 51 CH. HD. SCREW | } CAPACITOR FIXING | 98 CH. HD. SCREW } CAPACITOR PANEL FIXING | |
| 52 SHAKEPROOF WASHER | | 99 SPRING WASHER | |
| 53 CAPACITOR MOUNTING PANEL | | 101 C/SK. HD. SCREW (BY-PASS VALVE FIXING) | |
| 54 STUD | } CAPACITOR PANEL FIXING | 104 BY-PASS VALVE HOUSING | |
| 55 LOCKNUT | | | 185 RD. HD. SCREW } INSPECTION PLATE FIXING |
| 56 PLAIN WASHER | | 186 SPRING WASHER | |
| 57 CH. HD. SCREW (6BA) | } CAPACITOR COVER FIXING | 187 INSPECTION PLATE | |
| 58 SELF-LOCKING NUT | | | 188 CIRCLIP (BY-PASS FILTER RETAINING) |
| 59 SPRING WASHER | | | 189 C/SK. HD. SCREW (HINGE PLATE FIXING) |
| 60 CH. HD. SCREW (4BA) | | 197 HINGE PLATE | |
| 61 SPRING WASHER | | 198 HINGE PIN | |
| 62 GASKET | | 199 MOTOR BREATHER ASSEMBLY | |
| 63 BLANKING RING | } BLANKING RING FIXING | 203 RD. HD. SCREW | |
| 64 CH. HD. SCREW | | | 204 SHAKEPROOF WASHER |
| 65 SHAKEPROOF WASHER | | 205 WATER DRAIN VALVE | |
| 66 FILTER (BY-PASS DUCT) | | 206 C/SK. HD. SCREW (DRAIN VALVE FIXING) | |
| 71 GASKET (BY-PASS DUCT SECURING) | | 207 SEAL WASHER | |
| 73 FLAP VALVE PLATE | | 208 GASKET (OUTLET CONNECTOR/ VOLUTE) | |
| 74 OUTLET CONNECTOR CASTING | | | |
| 80 ELECTRICAL CONNECTION | | | |
| 81 RD. HD. SCREW | } ELECTRICAL CONNECTION SECURING | | |
| 82 SHAKEPROOF WASHER | | | |

Fig. 16. Part sectional view of pump/motor assembly

RESTRICTED

Note . . .

Do not separate the volute assembly if the seal is in good condition. If the two halves are separated keep them together for later assembling as a matched pair.

- (4) Withdraw the bellows gland seal body assembly (148) from the pump spindle, using the extractor tool SPE.17373 (fig. 3) and remove any shims (147) that may be fitted. Do not attempt to remove the carbon seal ring.

Removing the bellows unit assembly (fig. 1)

7. After removing the bevel gear and upper bearing assembly (basic chap, para. 7 and 8), remove the bellows unit as follows:—

- (1) Pre-heat the pump casting to 125-150 deg.C., and use the tools illustrated in fig. 18 to press out the bellows unit assembly.
- (2) Remove the three self-tapping screws (153) and withdraw the bellows sleeve (202).
- (3) Use the tools illustrated in fig. 19 and press the bellows gland out of its housing.

Note . . .

- (1) *The bellows gland need only be removed if the seal face is badly scored or if the seat is damaged in any way.*
- (2) *If the self-tapping screws break off during their removal, the remaining portion of the screws should be ground flush with the top surface of the housing, after removing the bellows gland.*

ASSEMBLING**Pump unit***Reaming the carbon bearing (fig. 1)*

8. (1) Using a pump casting (105) without the bellows housing sub-assembly, fit the lower bearing housing assembly (136) and secure with five screws (146).
- (2) Lubricate the carbon with kerosene fuel, and using the special reamer SPE.17378, guide bush SPE.17376 and collar SPE.17377 (fig. 3) ream the bearing to the size given in Table 3; take care not to chip the carbon.

- (3) Mark the lower bearing housing assembly and the pump casting to ensure that they will both be assembled into the same pump unit, in similar positions, at a later stage of assembling.

- (4) Remove the bearing housing.

Assembling the bellows unit (fig. 1)

9. If any of the drive screws (153) were broken during dismantling, ensure that the broken screws have been ground off flush and that three new holes have been drilled in the top face of the bellows gland housing (200) as detailed in Table 2, then proceed as follows:—

- (1) Pre-heat the bellows gland housing (200) to between 125 and 150 deg.C. then smear the grooves in the housing with Hermeticoll jointing compound.
- (2) Use the special tools illustrated in fig. 20 and press the gland into the housing. The top face of the bellows shroud must be 0.5 mm. above the top surface of the housing.
- (3) ◀ Using the fixture illustrated in fig. 21, pressure test the gland housing assembly, by immersing the assembly in water and applying air pressure at 20 lb/in² to the fixture adapter. Observe for air bubbles indicating leakage between the bellows gland and the housing; there must be no leakage.
- (4) Fit a new paper gasket (154) over the end of the bellows gland and secure the sleeve (202) to the housing with three self-tapping screws (153). ▶
- (5) After the pressure test, remove excess water, using a jet of dry compressed air, then complete the drying of the assembly in a ventilated oven.

Fitting the bellows unit into the pump casing (fig. 22)

10. (1) Pre-heat the pump casting to between 125 and 150 deg.C. then smear the lower portion of the housing with Hermeticoll jointing compound.
- (2) Use the tools illustrated in fig. 22 and press the housing into position; ensure that the shoulder on the housing abuts the shoulder in the pump casing. Wipe off any exuded jointing compound.

~~RESTRICTED~~

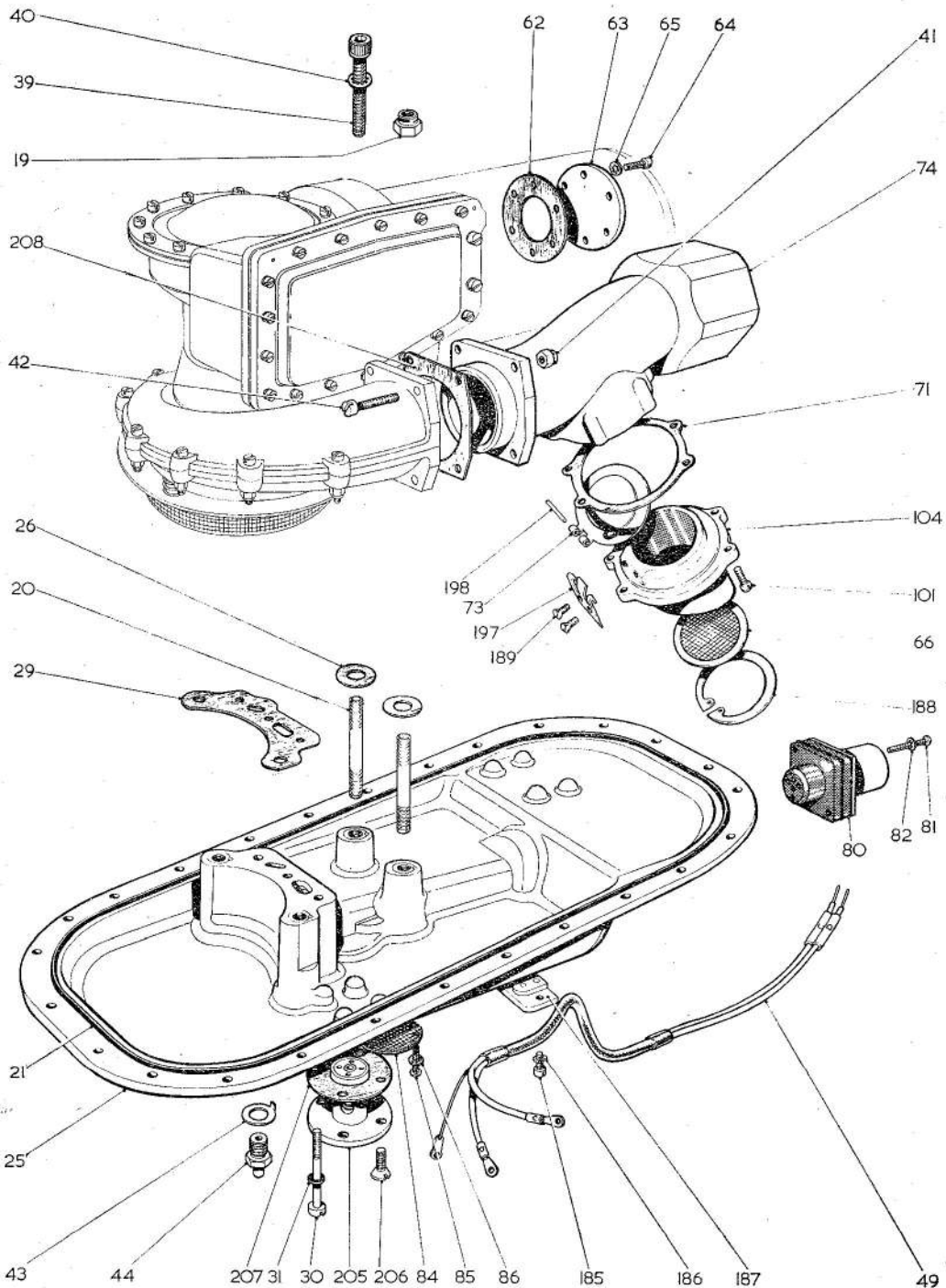

Fig. 17. Exploded view of mounting plate and outlet connector

~~RESTRICTED~~

KEY TO FIG. 17

- | | |
|--|---|
| 19 SELF-LOCKING NUT | 73 VALVE PLATE |
| 20 STUD | 74 OUTLET CONNECTOR |
| 21 SEAL RING (MOUNTING PLATE) | 80 ELECTRICAL CONNECTION |
| 25 MOUNTING PLATE | 81 RD. HD. SCREW } ELECTRICAL |
| 26 SEAL WASHER (VOLUTE/MOUNTING PLATE) | 82 SHAKEPROOF WASHER } CONNECTION FIXING |
| 29 GASKET (VOLUTE/MOUNTING PLATE) | 84 MOTOR BREATHER ASSEMBLY |
| 30 CH. HD. BOLT } MOUNTING PLATE FIXING | 85 RD. HD. SCREW } MOTOR BREATHER |
| 31 "SELOC" WASHER } MOUNTING PLATE FIXING | 86 SHAKEPROOF WASHER } FIXING |
| 39 CAP SCREW } PUMP/MOUNTING | 101 C/SK. HD. SCREW (BY-PASS VALVE FIXING) |
| 40 SHAKEPROOF WASHER } PLATE FIXING | 104 BY-PASS VALVE HOUSING |
| 41 SELF-LOCKING NUT } OUTLET/VOLUTE FIXING | 185 RD. HD. SCREW } INSPECTION PLATE FIXING |
| 42 CH. HD. SCREW } OUTLET/VOLUTE FIXING | 186 SPRING WASHER } INSPECTION PLATE FIXING |
| 43 TAB WASHER | 187 INSPECTION PLATE |
| 44 GLAND DRAIN | 188 CIRCLIP (BY-PASS FILTER RETAINING) |
| 49 ELECTRIC LEAD SUB-ASSEMBLY | 189 C/SK. HD. SCREW (HINGE PLATE FIXING) |
| 62 GASKET | 197 HINGE PLATE |
| 63 BLANKING PLATE | 198 HINGE PIN |
| 64 CH. HD. SCREW } BLANKING PLATE | 205 WATER DRAIN VALVE |
| 65 SHAKEPROOF WASHER } FIXING | 206 C/SK. HD. SCREW (DRAIN VALVE FIXING) |
| 66 BY-PASS FILTER ASSEMBLY | 207 SEAL WASHER |
| 71 GASKET (BY-PASS VALVE/OUTLET CONNECTOR) | 208 GASKET (OUTLET CONNECTOR/VOLUTE) |

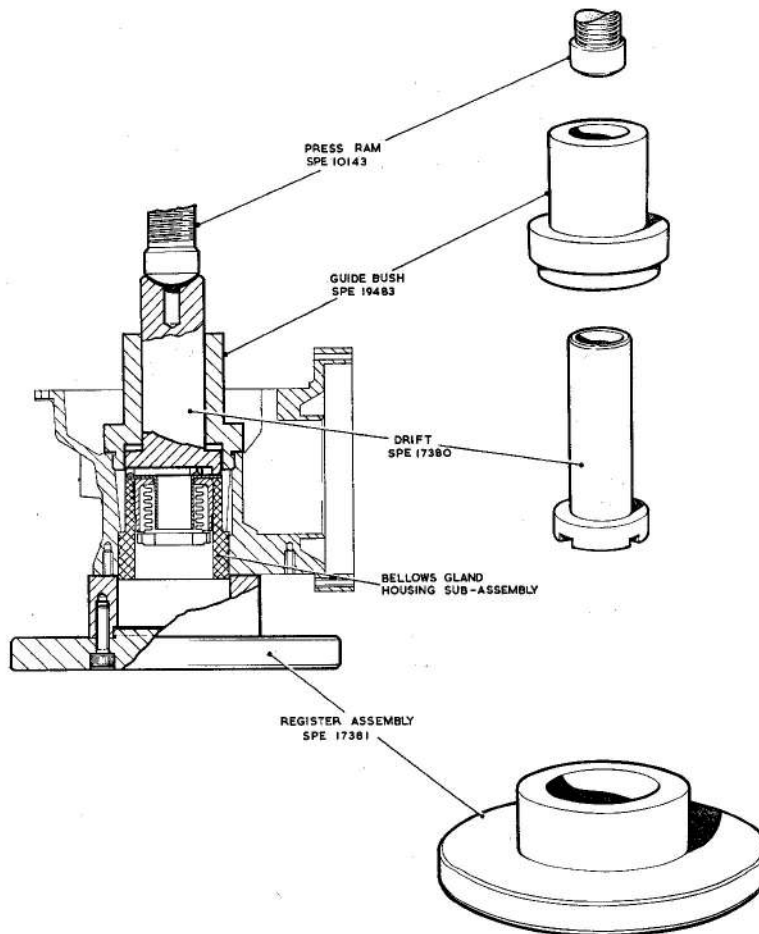

Fig. 18. Bellows housing removal

RESTRICTED

(3) Check the size of the bellows gland housing bore, after fitting, and compare it to the size detailed in Table 3.

(4) Using the existing tapped holes in the casing as a guide, drill through the bellows housing with a No. 44 drill (0.086 in. dia.) taking care not to damage the bellows unit (fig. 23).

Note . . .

These holes provide access of fuel to the unit faces for lubricating purposes.

(5) Use compressed air, at reduced pressure to ensure that no swarf from the drilling, has been trapped in the bellows gland convolutions.

Assembling the volute casing (fig. 1)

11. If the volute assembly was completely dismantled, re-assemble using the original paired upper and lower volute castings (144 and 142), proceed as follows:—

(1) Fit a new gasket (143) and smear the mating surfaces with Wellseal jointing compound.

(2) Assemble the castings with the seven screws (145) inserted from the top side and secure with the self-locking nuts (141).

(3) Renew any damaged studs (137) in the lower volute casting.

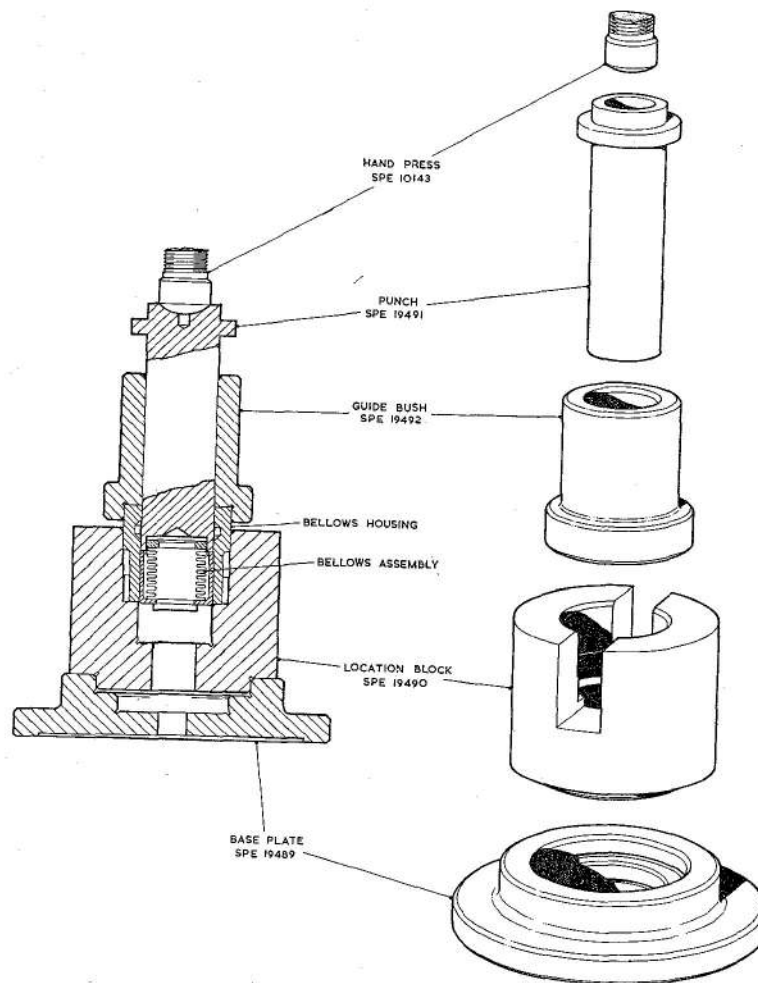

Fig. 19. Bellows gland removal from housing

RESTRICTED

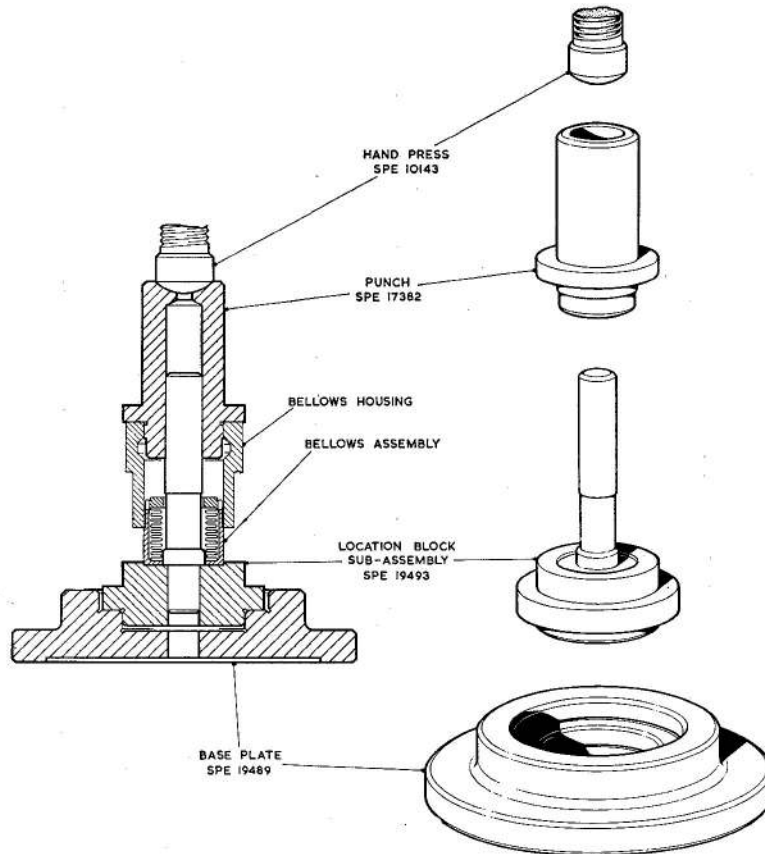

Fig. 20. Assembly of the bellows gland to housing

(4) Paint the mating surfaces of the pump casting (105) and the volute assembly with Wellseal jointing compound. Fit the gasket (120) and secure the volute assembly to the pump casting with three socket-head screws (121) and shakeproof washers (122).

Assembling the by-pass valve and delivery outlet (fig. 17)

12. Check the shaft components, and assemble the upper bearing housing, carry out the bellows gland loading procedure and assemble the centrifugal impeller and helix as detailed in the basic chapter, then proceed as follows:—

(1) Assemble the valve plate (73) and hinge plate (197) with the hinge pin (198) which should be crimped at each end.

Ensure that the valve is assembled with the dished side uppermost, and check that it hinges freely.

(2) Secure the hinge plate to the housing (104) with two countersunk screws (189) and peen metal into the screw slots to lock them.

(3) Place the by-pass filter assembly (66) in the valve housing (104) and retain it with the circlip (188).

(4) Place a new gasket (71) on the outlet connector (74) and secure the by-pass valve sub-assembly with six countersunk screws (101); peen metal into the screw slots to lock them.

(5) Fit the inlet filter as detailed in the basic chapter.

RESTRICTED

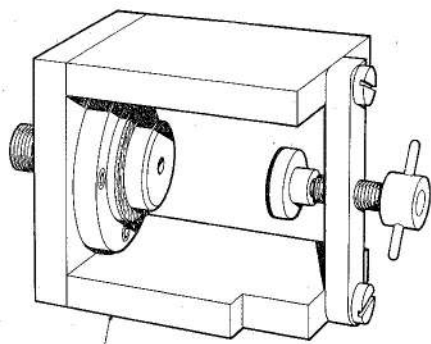

GLAND HOUSING SUB-ASSEMBLY
PRESSURE TEST FIXTURE
SPE. 19518

Fig. 21. Gland housing sub-assembly pressure test fixture

Fitting the motor unit to the pump unit

13. The reconditioning and assembling instructions for the motor are identical to the procedures given in the basic chapter. Carry out the operations as detailed in the basic chapter for:—

- (1) Bevel pinion shimming
- (2) Gear alignment
- (3) Assembling the outer motor casing
- (4) Assembling the gear box cover.
- (5) Assembling the capacitor units.

Attaching the suppressor housing cover and electrical connection blanking plate (fig. 1 and 17)

14. Secure the suppressor cover (45) with 4 B.A. screws (60) and spring washers (61) in two positions and with 6 B.A. screws (57),

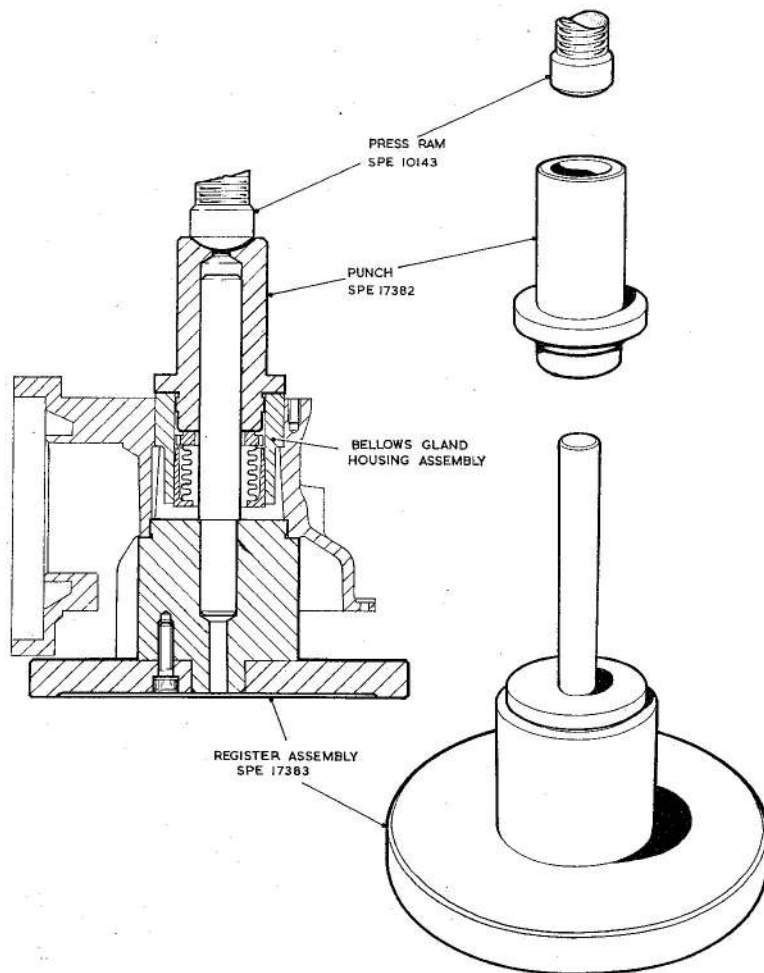

Fig. 22. Bellows gland housing assembly to pump casting

RESTRICTED.

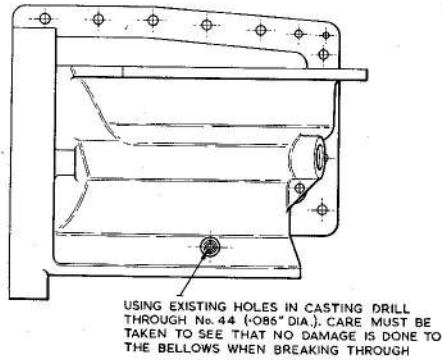

Fig. 23. Bellows gland lubrication hole drilling

spring washers (59) and self-locking nuts (58) in fourteen positions; in the latter positions the spring washers are positioned under the self-locking nuts. Smear the mating surfaces of the blanking ring (63) and pump body casting (105) with Wellseal jointing compound, then fit a new gasket (62) and secure the ring with six screws and shakeproof washers (64 and 65).

Pressure testing the pump assembly (fig. 24)

15. Fit the pressure test blanking plate SPE.17402 and the gasket SPE.17403 to the undersurface of the volute extension, and house the motor leads in the tube of the blanking plate, then carry out the pressure test as detailed in the basic chapter (para. 42).

Assembling the inclined sump mounting plate (fig. 17)

16. (1) Replace any damaged studs (20) in the sump casting and ensure that the studs project at least 0.7 in.
- (2) Fit a new joint ring (21) in the flange groove of the mounting plate (25) as follows:—
- Remove the flash on all corners of the joint ring.
 - Clean the groove of the mounting plate with No. 6104 cleaner.
 - Prime with Boscolite Primer 147A and allow to dry for at least one hour.
 - Coat the groove with Boscoprene Cement J.671, parts A and B. Allow to dry for at least half-an-hour.
 - Add a second coat of Boscoprene Cement as in (d) and allow to dry for $\frac{1}{4}$ hour.

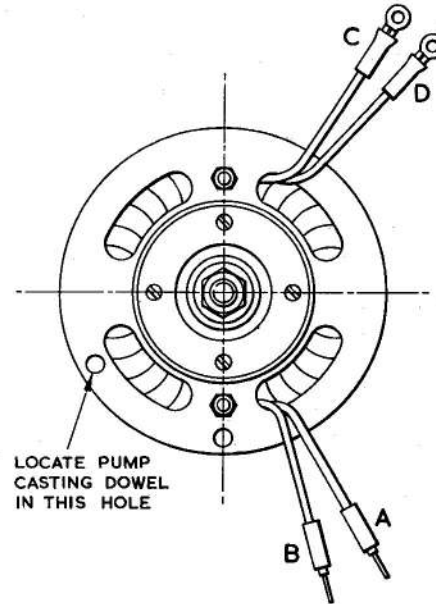

Fig. 24. Motor lead positioning

(f) Assemble the ring into the groove. Do not attach the ring when assembling; the rubber must be pressed back as it is fed into the groove.

(g) Allow to cure at room temperature for 24 hours.

(3) Refit the motor breather (84) and secure it with three roundhead screws (85) and shakeproof washers (86).

(4) Refit the gland drain (44) and tab washer (43). Locate the bent tab of the washer in the small casting hole and bend the large tab against the side of the locknut after tightening.

(5) Position the water drain valve (205) and seal washer (207) and secure the valve with four countersunk screws (206).

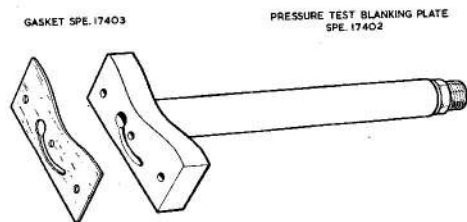

Fig. 25. Pressure test tools

RESTRICTED

(6) Smear the mating surface of the pump volute and mounting plate with Wellseal jointing compound. Place new washers (26) and gasket (27) on the mounting plate and secure it to the pump assembly with two $\frac{1}{4}$ in. B.S.F. self-locking nuts (19), two socket head screws (39) with shakeproof washers (40) and three cheese-head bolts (30) with "Seloc" washers (31).

17. *Connect the electrical leads as follows:—*
(1) Solder the motor unit leads marked "A" and "B" to pins A and B respectively on the connection block (80) and connect the leads marked "C" and "D" in a similar manner to pins C and D. No connection is made to pin E. Ensure

that the joints are not "dry" soldered, and do not allow solder to run along a lead, as this may cause the lead to fracture when assembling the plug.

(2) Re-assemble the pins into their correct positions in the plates of the connection block and secure the plug to the mounting plate (25) using four round-head screws (81) and shakeproof washers (82).

TESTING

18. The completed pump can be tested on the universal fuel pump test rig (Ref. No. 5G/3494) in accordance with the procedure and data given in the basic chapter.

RESTRICTED

Appendix 1

PUMP, FUEL, SPE.1207, Mk. 1

General

1. This appendix details the differences between the SPE.1207 Mk. 1 fuel pump and the SPE.1207 Mk. 2 fuel pump. Where no details are given for dismantling or assembling, it can be assumed that the procedures given in the basic chapter and the chapter on the Mk. 2 pump are not affected.

Suppressor panel assembly

2. The capacitor cover is provided with a separate gasket in place of the Mk. 2 cover which has a bonded seal washer, and is a sheet metal cover as opposed to a die cast cover; a backing plate is also fitted over the cover flange. It is recommended that a Mk. 2 cover is fitted as a replacement whenever possible.

Gear box cover

3. A sheet metal cover with a separate gasket, and with a backing plate fitted over the cover flange is used on the Mk. 1 pump. It is recommended that a Mk. 2 cover with a bonded seal washer is fitted as a replacement, whenever possible.

Upper bearing assembly

4. The Mk. 1 upper bearing assembly is illustrated in the basic chapter (fig. 4) and the procedures for dismantling and assembling are also given in the basic chapter.

Bellows unit assembly

5. The sleeve (fig. 1, item 202) is not fitted to Mk. 1 pumps but the procedure detailed for Mk. 2 pumps applies except for references to the bellows sleeve (202) and the gasket (154).

RESTRICTED

This file was downloaded
from the RTFM Library.

Link: www.scottbouch.com/rtfm

Please see site for usage terms,
and more aircraft documents.

