

## Chapter 2

## HOTCUP, G.E.C. TYPE H.O. 3384

## LIST OF CONTENTS

	<i>Para.</i>	<i>Testing</i>	<i>Para.</i>
<i>Introduction</i> ... ..	1	<i>Insulation resistance test</i> ... ..	5
<b>Description</b> ... ..	2	<i>Continuity test</i> ... ..	6
<b>Servicing</b> ... ..	4	<i>Functional test</i> ... ..	7

## LIST OF ILLUSTRATIONS

	<i>Fig.</i>	<i>Fig.</i>	
<i>Part sectional view of hotcup</i> ... ..	1	<i>Circuit diagram</i> ... ..	2

## LEADING PARTICULARS

<i>Hotcup, G.E.C. Type H.O.3384</i> ... ..	<i>Ref. No. 5V/225</i>
<i>Voltage</i> ... ..	28 volts
<i>Rating</i> ... ..	500 watt
<i>Weight</i> ... ..	2 lb. 8 oz.
<i>Capacity</i> ... ..	1½ pints

## Introduction

1. The hotcup, G.E.C. Type H.O.3384, is designed to heat small quantities of liquid in a short time, the time taken will vary with the liquid and the quantity. Intended for use in aircraft galleys, the hotcup plugs into a Cannon socket which is connected to the aircraft supply via an ON-OFF control switch and a relay. A Klixon thermostat is incorporated to protect the element should the hotcup be allowed to boil dry. This chapter deals with the 28 volt hotcup, details of the 112 volt version, G.E.C. Type H.O.3386, which is essentially similar in construction and operation are given in Section 11, Chapter 3. ▶

## DESCRIPTION

2. The hotcup consists of an inner container, an outer casing and a lid, a part sectional view is given in fig. 1. The inner container is of chromium plated copper and has a sheathed wire element hard soldered to the lower part, the outer casing and the lid are of chromium plated brass whilst the handle and knob are of black bakelite. The outer casing consists of the casing body and a base plate, the casing body fitting into the rim of the base plate. The inner container fits into the outer casing, the lip of the container fitting over the rim of the outer casing body. The assembly is secured by a ¼ in.

RESTRICTED

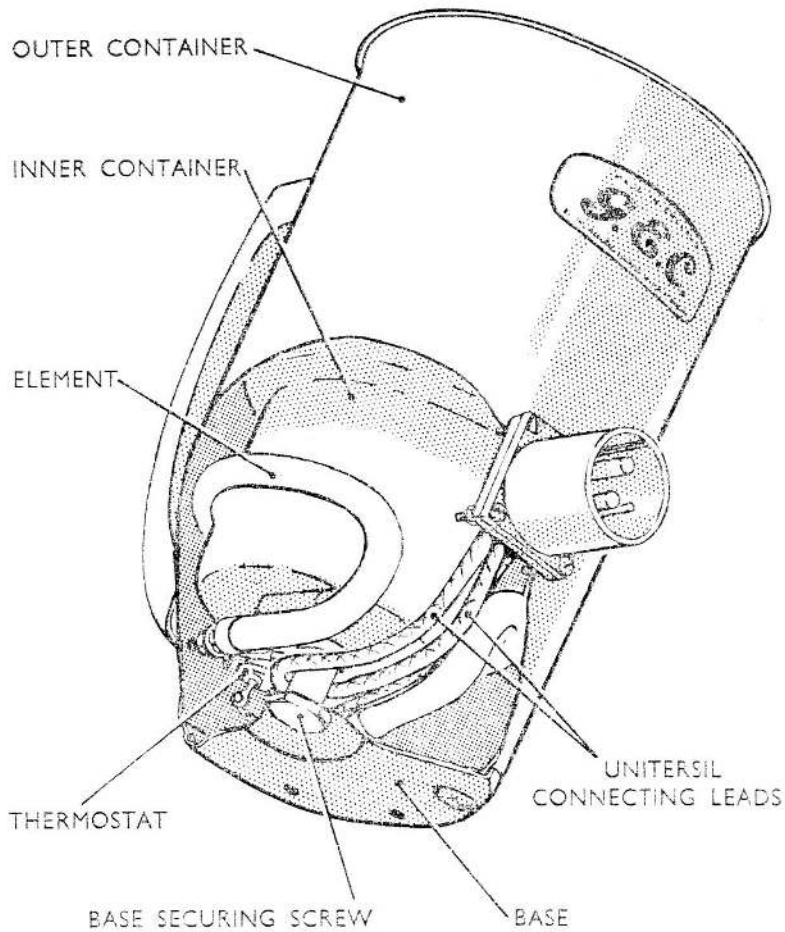

Fig. 1. Part sectional view of hotcup

B.S.F. hexagonal headed screw which passes through the base plate to engage with a sleeve nut soldered to the base of the inner container. The Klixon thermostat is secured to the base of the inner container.

3. The electrical connections to the hotcup are made by a 3-pole Cannon plug (KB 107/4), to the pins of which are soldered the unitersil connecting leads for the element and the thermostat. The two large pins are

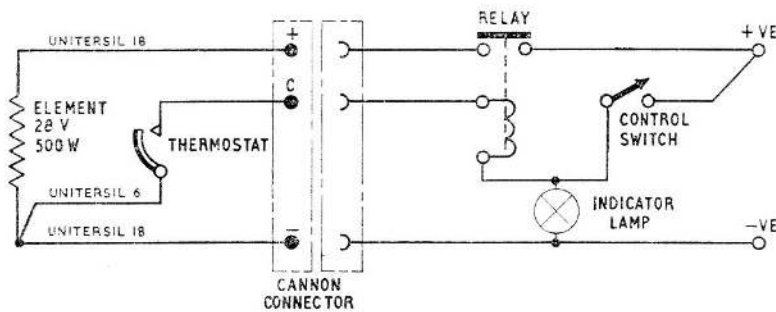

Fig. 2. Circuit diagram

**RESTRICTED**

connected to the element and the small pin is connected to the thermostat, a circuit diagram is given in fig. 2. Should the hotcup overheat, the thermostat will operate, breaking the relay circuit and thus opening the supply relay. It should be noted that the relay will again close if the hotcup is left connected to the supply, with the supply switch ON. It is important that where hotcups are stored plugged into the supply, that the control switch must be OFF. When in use the level of liquid in the hotcup must be above the ledge in the inner container.

### SERVICING

4. The hotcup should be examined for damage, and the connector plug pins examined for corrosion or signs of burning. Whenever electrical connections are disturbed for renewal purposes or inspection they should be liberally coated with silicone grease M.S.4 (Ref. No. 33C/9424829) when remade. The thermostat and Cannon plug may be renewed, access being gained by removing the  $\frac{1}{4}$  in. B.S.F. screw and the outer container base plate; when renewing the plug it will be found necessary to par-

tially withdraw the inner container to allow space in which to unsolder the unitersil cable. The handle is readily renewed by unscrewing the two securing screws.

### Testing

#### *Insulation resistance test*

5. The insulation resistance may be measured between the pins of the connector and the hotcup using a standard 250 volt insulation resistance tester, the reading obtained must be not less than 5 megohms.

#### *Continuity test*

6. The continuity of the element measured across the pins of the connector should be 1.567 ohms. The thermostat is normally closed and should be checked for continuity.

#### *Functional test*

7. The hotcup may be functionally tested by checking the time taken to boil one pint of water, the time taken should be approximately 12 minutes when the supply voltage is 28 volts.

This file was downloaded  
from the RTFM Library.

Link: [www.scottbouch.com/rtfm](http://www.scottbouch.com/rtfm)

Please see site for usage terms,  
and more aircraft documents.

