

Chapter 26

URN, 2 GALLON, TYPE HE 45386

LIST OF CONTENTS

	<i>Para.</i>		<i>Para.</i>
<i>Introduction</i>	1	<i>Water contents gauge</i>	8
Description	2	<i>Testing</i>	9
Servicing	5	<i>Insulation resistance test</i>	10
<i>Element renewal</i>	7		

LIST OF ILLUSTRATIONS

	<i>Fig.</i>
<i>General view</i>	1
<i>Circuit diagram</i>	2

LEADING PARTICULARS

Urn, 2 Gallon, Type HE 45386	Ref. No. 5V/242
<i>Nominal voltage</i>	28V
<i>Rating</i>	1000 Watts
<i>Overall dimensions—</i>	
<i>Height (Excluding lid)</i>	13 $\frac{3}{4}$ in.
<i>Width</i>	13 $\frac{1}{8}$ in.
<i>Depth</i>	12 $\frac{3}{4}$ in.
<i>Weight</i>	16 $\frac{1}{2}$ lb

Introduction

1. The G.E.C. Urn, Type HE 45386, is designed to boil quantities of water up to a maximum of 2 gallons. Overheat protection is incorporated in the event of the urn boiling dry or being used in an unfilled state.

DESCRIPTION

2. The urn consists of an inner casing of stainless steel separated from an outer casing of aluminium alloy by glass fibre lagging. A visual water level gauge is fitted to the front and an aluminium drain plug is situated in the bottom of the urn.

3. Four 250 watt heater elements are situated close to the bottom of the inner container and are switched via a relay by an on/off switch. A thermal cut-out is connected in series with the switch and relay coil, and provides overheating protection

4. The control box houses the main electrical connections to the urn, an on/off switch, a relay, two indicator lamps and the connections to the four heater elements. Access to these items is via a removeable cover on the control box.

RESTRICTED

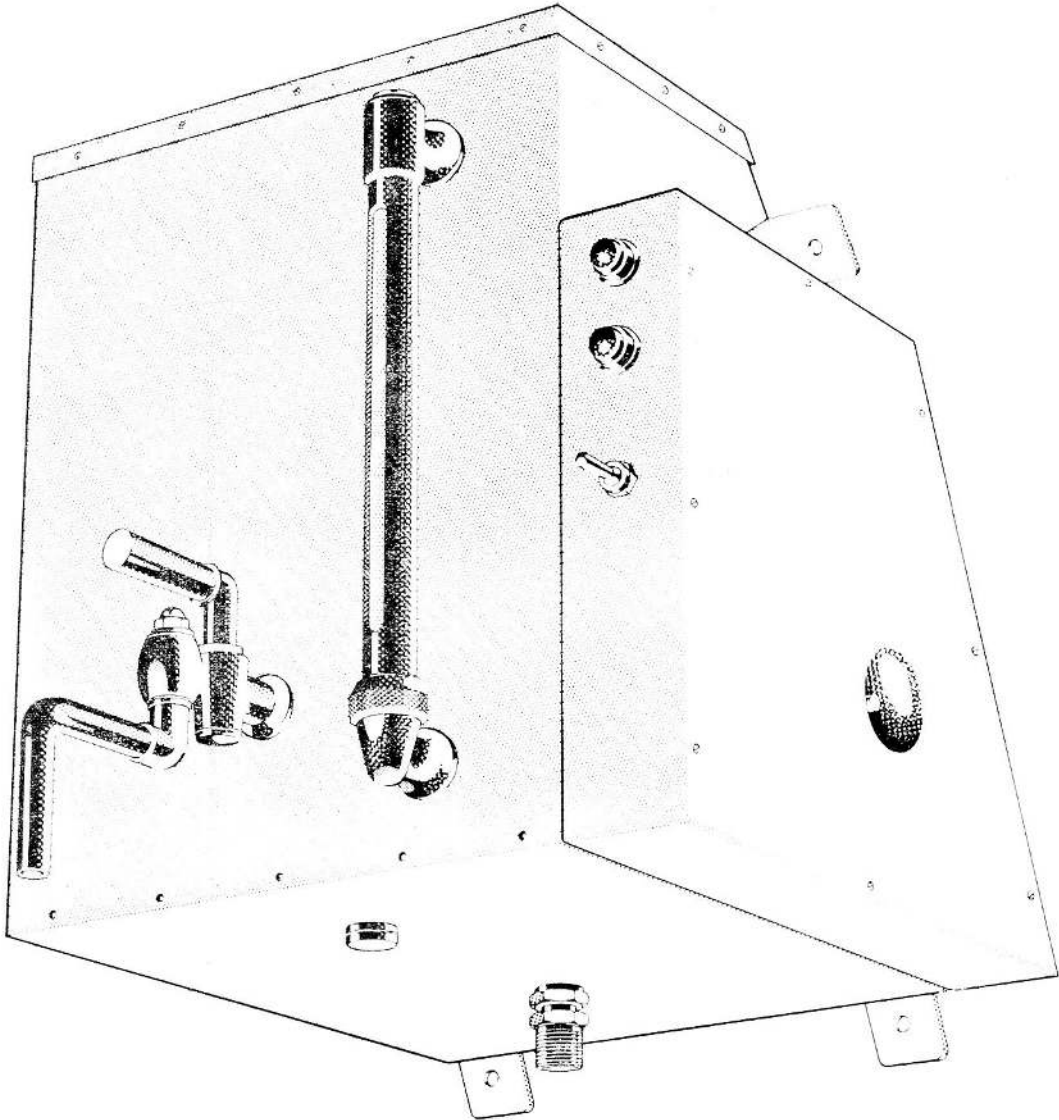

Fig. 1. General view

RESTRICTED

SERVICING

5. Inspect all watertight joints for signs of leakage or damage. Inspect the interior of the urn for deposits of scale or fur which may be removed by using a solution of one part glacial acetic acid to 16 parts of water. The required amount of solution should be boiled in the urn and allowed to stand for two to three hours, after which the solution should be drawn off and the loose scale or fur brushed out by hand. **NO SHARP METAL OR HARSH ABRASIVES SHOULD BE USED.**

6. The covers of the control box and heater compartment should be removed, and all electrical connections inspected for security of attachment and corrosion. Remove the

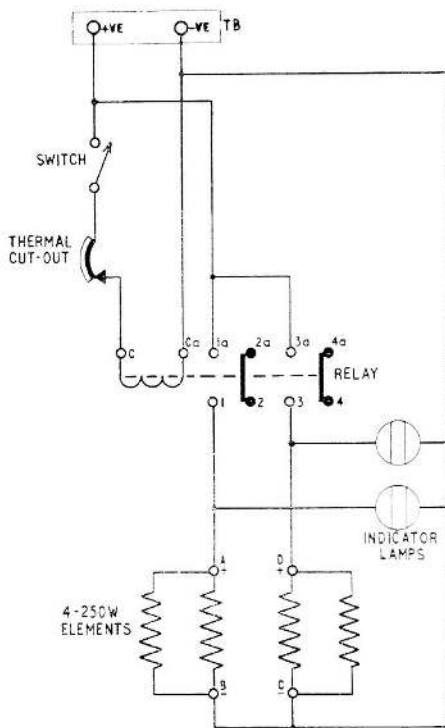

Fig. 2. Circuit diagram

relay cover and inspect the coil for signs of overheating, and the contacts for signs of burning and pitting. The relay may be serviced in accordance with 4343C, Vol. 1, Book 2, Sect. 3, Chap. 8.

Element renewal

7. (1) Remove the control box cover.
- (2) Remove the cut-out assembly.
- (3) Remove the element retaining nuts and withdraw the element assembly and gasket.
- (4) Remove the backing plate from the interior of the urn.
- (5) Before refitting a new element assembly, test the elements for continuity and insulation resistance.

Water contents gauge

8. The water contents gauge is similar to that described in Chapter 9 of this section to which reference may be made.

Testing

9. After servicing, the urn should be filled with water, boiled, and allowed to stand for approximately one hour after which all watertight joints should be inspected for signs of leakage. The thermal cut-out may be tested for operation by emptying the urn, connecting to a suitable supply and switching on. The time taken for the cut-out to operate, as indicated by the extinguishing of both indicator lamps, should be between 3 minutes 45 seconds and 4 minutes 30 seconds. If the cut-out does not operate within these limits, the gap in the bi-metal jaw may be adjusted.

Insulation resistance test

10. The insulation resistance of the urn should be tested using a 250 volt insulation resistance tester. The minimum reading obtained should be not less than 5 megohms.

RESTRICTED

This file was downloaded
from the RTFM Library.

Link: www.scottbouch.com/rtfm

Please see site for usage terms,
and more aircraft documents.

