

Chapter 9

FAN CIRCULATED OVEN, G.E.C. TYPE H.E. 47447 M61

LIST OF CONTENTS

	<i>Para.</i>		<i>Para.</i>
<i>Introduction</i>	1	<i>Motor renewal</i>	12
Description	2	<i>Door seating gasket renewal</i>	13
Operation	5	<i>Thermostat renewal</i>	14
Servicing	8	<i>Testing</i>	15
<i>Element renewal</i>	11		

LIST OF ILLUSTRATIONS

	<i>Fig.</i>
<i>Part cut-away view</i>	1
<i>Location of components</i>	2
<i>Circuit diagram</i>	3

LIST OF APPENDICES

	<i>App.</i>
<i>Standard serviceability test</i>	A

LEADING PARTICULARS

Fan circulated oven, G.E.C. Type H.E.47447 M61. Ref. No.

<i>Operating voltage</i>	115/200V, 3 phase, 4 wire, 400 c/s a.c.
<i>Power consumption</i>	
<i>Heating circuit</i>	3000 Watts
<i>Fan motor</i>	100 Watts
<i>Heating control</i>	
<i>High</i>	305°F (152°C)
<i>Medium</i>	255°F (124°C)
<i>Low</i>	210°F (99°C)
<i>Overall dimensions</i>	
<i>Length</i>	18.72 in.
<i>Width</i>	17.93 in.
<i>Height</i>	19 in.
<i>Weight</i>	47 lb.

RESTRICTED

Introduction

1. The fan circulated oven, G.E.C. Type H.E.47447 M61 is designed to heat pre-cooked frozen food for in-flight catering. The oven has two groups of heating elements and a high speed 3.5 in. fan which circulates hot air around the oven interior, heating the food quickly and evenly. A part cut-away view of the oven is given in fig. 1.

DESCRIPTION

2. The oven comprises an outer shell with sides, back and top of aluminium alloy and the bottom of stainless steel. The inner shell,

together with the front and the control box which is mounted on the top of the oven, is constructed from stainless steel. The cavity between the inner and outer shell of the oven is packed with fibre glass lagging, whereas the cavity between the inner and outer shell of the door is packed with aluminium foil.

3. Two groups of elements and an electrically driven impeller are fitted to a baffle at the back of the oven. Electrical connections to the heater elements, thermostats, fan and fan capacitor are housed in a wiring com-

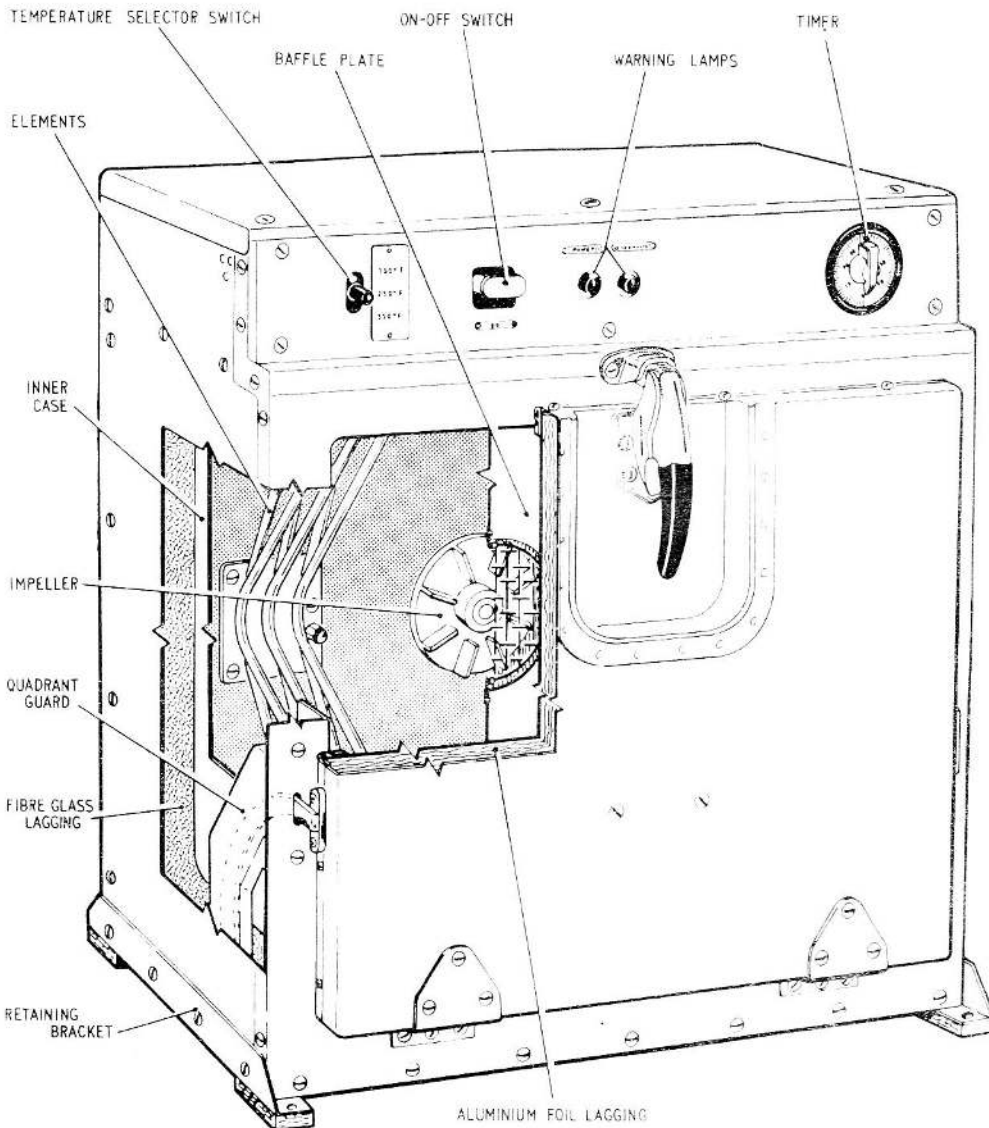

Fig. 1. Part cut-away view

RESTRICTED

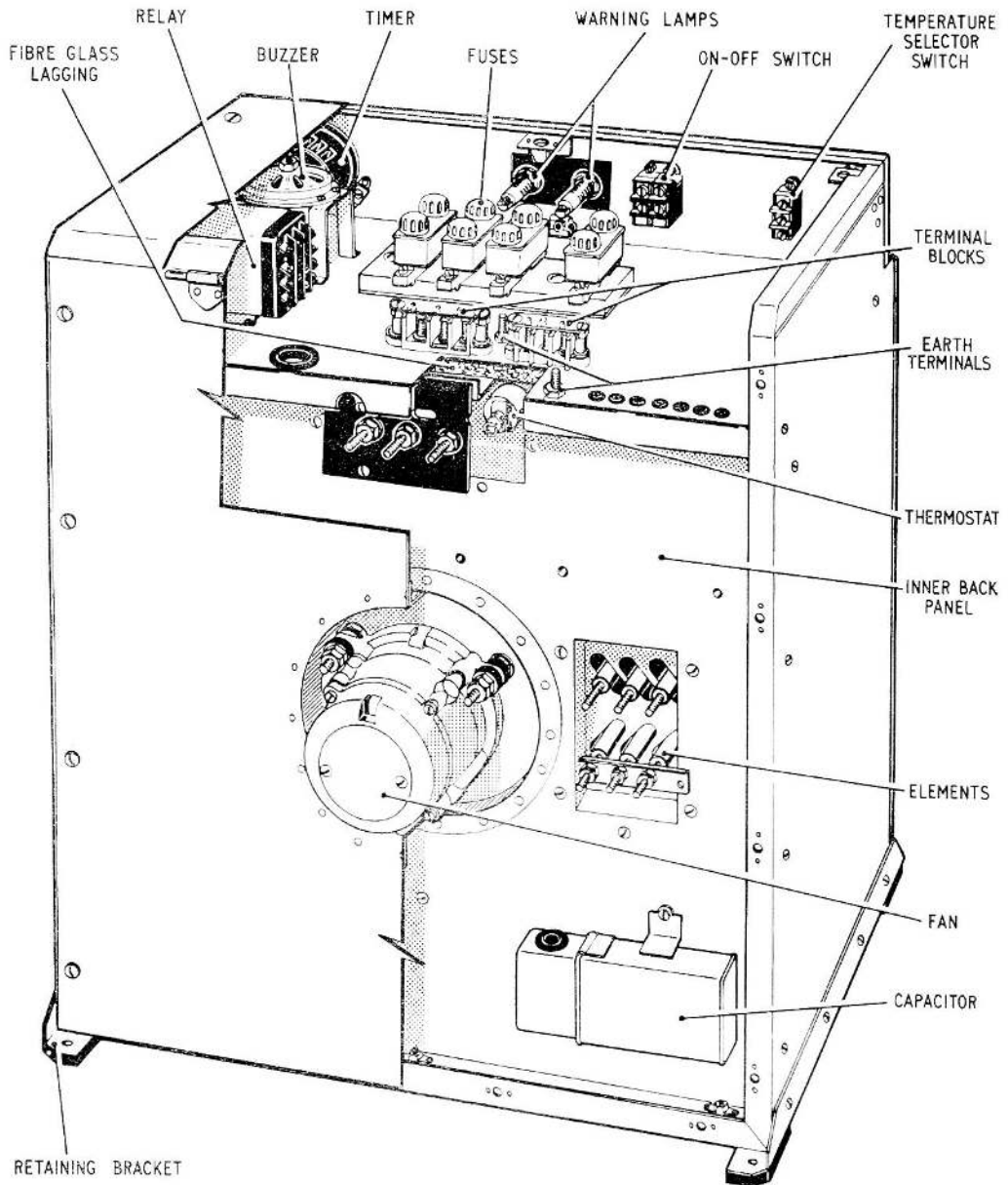

Fig. 2. Location of components

partment at the rear of the oven. The control box houses the control equipment for the oven temperatures which consists of a MAIN switch, a temperature selector switch, a relay, a mechanical timer, two terminal blocks and four fuses. A buzzer is also fitted in the control box to give an audible warning of the end of the timing cycle.

4. The automatic timer may be set for any period between 0 and 60 minutes. The temperature selector switch has three positions and, in conjunction with three thermostats, controls the temperature at 305°F, 255°F, and 210°F. This gives a centre oven temperature of 300/325°F, 255/287°F, and 215/240°F respectively.

RESTRICTED

200V. 3-PHASE. 4-WIRE. 400 c/s

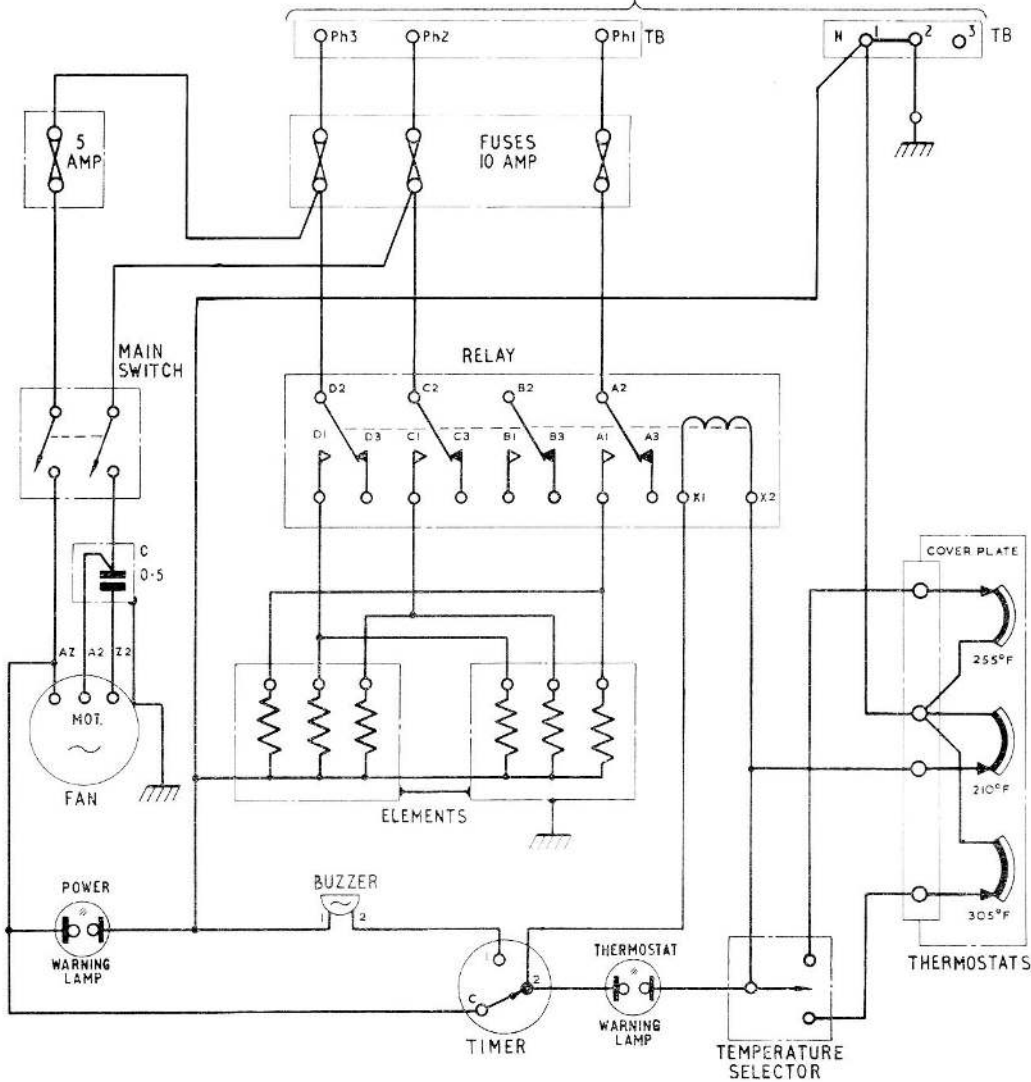

Fig. 3. Circuit diagram

OPERATION

5. Referring to fig. 3, with the timer set to the required time, the temperature switch set to the required temperature, and the MAIN switch set to ON, the supply is routed via phases 2 and 3 through the motor fuse and double pole MAIN switch to the motor and motor capacitor.

6. With the temperature selector switch set at 210°F, the supply is routed from the double pole switch to terminal C of the timer, through the timer to terminal 2. From terminal 2 of the timer, a supply is routed

through the relay coil to the 210°F thermostat, through the closed contacts of the thermostat to neutral. This energizes the relay and the heater supply is then obtained from phases 1, 2 and 3 through the relay contacts to the heaters. The thermostat warning lamp is supplied from terminal 2 on the timer.

7. The temperature selector switch is a change over switch and routes the neutral side of the relay coil through the desired temperature thermostat. Once the desired temperature is reached, the thermostat con-

RESTRICTED

tacts open which causes the relay to de-energize and remove the heater supply. At the end of the timing cycle, the timer contacts change over making contacts C and 1 and breaking contacts C and 2. This routes a supply to the warning buzzer, extinguishes the thermostat warning lamp, and removes the supply to the relay coil.

SERVICING

8. Servicing in situ is limited to examination for damage, security of attachment, cleanliness, and a functional test as described in para. 3 of Appendix A to this chapter. Clean all metal parts with a damp cloth and dry with a clean dry cloth. **DO NOT USE PAPER TOWELS.** Mild abrasives may be used to remove burnt-on deposits.

9. With the oven removed to a servicing bench, remove the top and rear panel covers. Examine all items for security of mounting, cleanliness, and freedom from damage. Examine all connections for tightness, dry or fractured joints, and damaged insulation. Examine the relay coil for signs of overheating, and the contacts for pitting or burning. The relay may be serviced in accordance with the appropriate chapter in A.P.4343E, Vol. 1, Book 4.

10. The buzzer tone may be adjusted if necessary by releasing the adjusting screw locking nut, which may be found at the centre of the buzzer cover, and adjusting the tone adjusting screw. Should the buzzer fail to function, it should be tested for continuity and insulation resistance and renewed if at fault. Examine the fuses and test for continuity. The time switch may be serviced in accordance with the relevant chapter in A.P.4343C, Vol. 1, Book 1, and the motor in accordance with A.P.4343D, Vol. 1, Book 4. Ensure that the fan blade is firmly secured to the motor shaft. The heater elements may be tested for continuity and replaced if necessary.

Element renewal

- 11.** (1) Remove the baffle plate retaining screw which is situated at the centre of the lower edge of the baffle plate.
- (2) Slide the baffle plate vertically and lift out.

- (3) Remove the rear panel cover.
- (4) Remove the electrical connections and shorting bar from the elements.
- (5) Remove the element plate retaining screws.
- (6) Withdraw the element assembly and sealing gasket from the oven interior, ensuring that any gasket sealing agent is removed from the oven back-plate. **DO NOT USE SOLVENTS.**
- (7) Before refitting a new element assembly, it should be tested for continuity and insulation resistance.
- (8) A suitable sealing agent (Seclastik or suitable equivalent) should be applied to each seating surface of the element plate and gasket on assembly ensuring that all excess sealant is cleaned off.

Note . . .

It is important that when the elements are secured in position that there is a minimum clearance of 0.06 inches between the back of the oven interior and the elements, and between the elements and the baffle plate. The elements should not foul the impeller and a minimum clearance of 0.03 inches should exist between the sheaths of the element loops.

Motor renewal

- 12.** (1) Remove the baffle plate retaining screw which is situated at the centre of the lower edge of the baffle plate.
- (2) Slide the baffle plate vertically and lift out.
- (3) Loosen the impeller retaining screw locknut and slacken the retaining screw. Remove the impeller from the fan shaft.
- (4) Support the motor and remove the three nuts from the motor retaining screws. Withdraw the motor and remove the thrower ring and grommet.

RESTRICTED

Door seating gasket renewal

13. (1) Remove the nineteen screws securing the retaining strip to the inner door panel. Remove the retaining strip.
- (2) Peel off and discard the old door gasket and carefully scrape off any remaining adhesive.
- (3) Temporarily fit the new gasket to the inner door panel and mitre the corners. The joining of the gasket should be at the right hand side adjacent to the quadrant.
- (4) Remove the new gasket and spread a thin layer of Araldite on both surfaces to be bonded. Immediately re-fit the gasket to the inner door panel.
- (5) Position the retaining strip onto the door gasket and secure with the nineteen screws. Wipe off all surplus Araldite. Lightly clamp the door gasket to the door panel whilst the resin cures, which is for approximately 24 hours at 68°F (20°C).

Thermostat renewal

14. (1) Identify each electrical cable to its appropriate thermostat and disconnect the cable.
- (2) Remove the four cover plate retaining screws and washers, and remove the cover plate.
- (3) Remove the appropriate thermostat from its clip. The medium heat thermostat is on the right, the low heat in the centre, and the high heat on the left as viewed from the rear of the oven.

Note . . .

The outside shell of the thermostat forms the operating element and must not be held rigid inside the clips but must be allowed freedom of movement.

Testing

15. The oven may be tested in accordance with the standard serviceability test, Appendix A to this chapter.

Appendix A**STANDARD SERVICEABILITY TEST**

for

FAN CIRCULATED OVEN, G.E.C. TYPE H.E. 47447 M61**Introduction**

1. The following tests may be applied to ascertain the serviceability of the oven, or prior to its installation in an aircraft.

TEST EQUIPMENT

2. The following test equipment or suitable equivalents will be required.

- (1) 200V, 3 phase 4 wire, 400c/s a.c. supply.
- (2) Stop watch.
- (3) Insulation resistance tester, Type A. (Ref. No. 5G/1621).

TEST PROCEDURE**Functional test**

3. (1) Connect the oven to the 200V a.c. supply.
- (2) Set the temperature selector switch to the 210°F position.
- (3) Set the timer to 30 minutes and the main on/off switch to ON. Ensure that the POWER and THERMOSTAT warning lamps are illuminated, and that the fan motor is running.
- (4) Before the time period has elapsed, the THERMOSTAT warning lamp

should extinguish. When this occurs, switch the temperature selector to 255°F and the warning lamp should illuminate.

(5) After a few minutes the warning lamp should extinguish. Switch the temperature selector to 305°F and ensure that the warning lamp illuminates. Ensure that the lamp is extinguished after a few minutes.

(6) When the time period of 30 minutes has elapsed the buzzer should sound.

Timing test

4. (1) Set the timer dial to 60 minutes.
- (2) Start the stop watch and check the timer.

Insulation resistance test

5. With all external supplies removed and the oven still warm, using an insulation resistance tester Type A (Ref. No. 5G/1621) test between each terminal on the two terminal blocks and the metal casing. Remove the warning lamps, and with the MAIN switch in the ON position, repeat the above test with the TEMPERATURE SELECTOR in each position in turn. The minimum reading obtained should be not less than 5 megohms.

RESTRICTED

This file was downloaded
from the RTFM Library.

Link: www.scottbouch.com/rtfm

Please see site for usage terms,
and more aircraft documents.

