

Chapter 21

MOUNTING BASES, GRAVINER, TYPE D2240 AND D2497

LIST OF CONTENTS

	<i>Para.</i>		<i>Para.</i>
<i>Introduction</i>	1	Installation	5
Description		Servicing	6
<i>Mounting Type D2240</i>	2	<i>Insulation resistance test</i>	8
<i>Mounting Type D2497</i>	4		

LIST OF ILLUSTRATIONS

	<i>Fig.</i>		<i>Fig.</i>
<i>Mounting base, Type D2240</i>	1	<i>Connection diagram</i>	3
<i>Plan and sectional views of mounting base, Type D2497</i>	2		

LEADING PARTICULARS

Mounting base, Graviner, Type D2240	Ref. No. 5CZ/5918
Mounting base, Graviner, Type D2497	Ref. No. 5CZ/
<i>Overall dimensions of Type D2240 unit</i>	4.2 in. × 2.15 in. × 1.35 in.
<i>Overall dimensions of Type D2497 unit</i>	4.2 in. × 3.25 in. × 1.75 in.
<i>Weight of Type D2240 unit</i>	0.39 lbs.
<i>Weight of Type D2497 unit</i>	0.516 lbs.

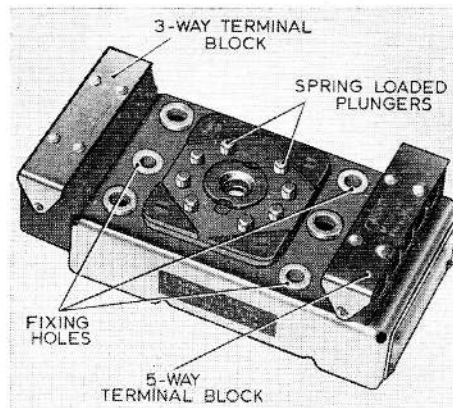

Fig. 1. Mounting base, Type D2240

RESTRICTED

Introduction

1. The Gravier, Type D2240 and D2497, mounting bases are used to mount the potted type of crash trip and Firewire relay units. They provide a quick release facility which enables the relay units to be removed from the aircraft without disturbing the connections to the warning circuits. The two mountings are basically similar, the Type D2497 being the anti-vibration version of the Type D2240 mounting base. This chapter deals only with the mounting bases, details of the relay unit are given in various chapters of this Section.

DESCRIPTION

Mounting Type D2240

2. The rectangular stainless steel chassis of the Type D2240 mounting base has a 3-way

and a 5-way terminal block mounted one at each end and a melamine contact plate assembly fitted at the centre. The contact plate carries eight spring loaded plunger contacts and is secured to the chassis by four screws in early models, later models have four spring loaded pins as shown inset in fig. 2. The two terminal blocks have hinged terminal covers and accommodate 6 B.A. ring type cable ends.

3. A 2 B.A. floating anchor nut beneath the centre of the contact plate accepts the relay unit securing stud when the unit is fitted. Correct alignment of the relay unit is ensured by three spigots which engage in locating holes in the mounting base. The three 2 B.A. or No. 10 unified bolts which secure the mounting base to the airframe pass through three other holes in the base.

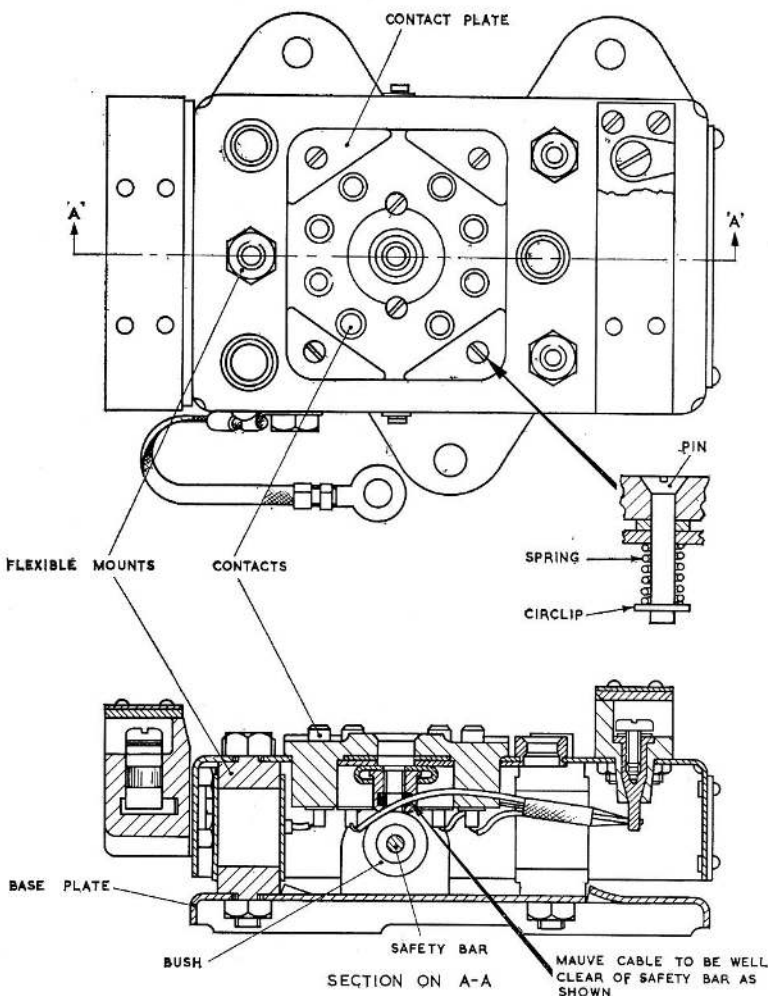

Fig. 2. Plan and sectional views of mounting base, Type D2497

RESTRICTED

Mounting Type D2497

4. The Type D2497 mounting base consists of a modified Type D2240 mounting secured to a base plate by three flexible mounts (Instrumounts). The modifications to the base unit introduce No. 6 Unified terminal screws in the terminal blocks in lieu of 6 B.A. screws and provision for the attachment of a safety bar. The safety bar is fitted across the underside of the chassis, it is secured through holes in each side of the chassis by circlips and passes through oversize bushed lugs on the mounting plate. This permits normal movement of the control unit and mounting base so as to damp-out vibration due to the airframe, but should any of the flexible mounts fail the safety bar prevents excessive movement. The whole assembly is secured to the airframe by bolts which pass through three lugs in the base plate.

INSTALLATION

5. When installing the Graviner Type D2497 mounting base the bonding lead which is bolted to the chassis of the unit must be secured beneath the adjacent base plate mounting bolt.

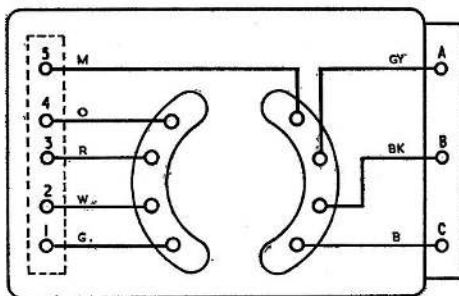

Fig. 3. Connection diagram

SERVICING

6. The mounting bases should be examined for cleanliness and freedom from mechanical damage to ensure that the contact plate and terminal block mouldings are not cracked, distorted or broken and that the mounting base is free from oil contamination. Contamination is more likely in certain aircraft installations where the Firewire control unit is fitted in exposed locations. The spring loaded plungers should be checked for freedom of movement by exerting a light pressure. They should also be checked for equal height when in the uncompressed position and for freedom from corrosion or pitting.

7. The three flexible mounts of the Type D2497 mounting base should be examined for deterioration and the spring loaded pins securing the contact plate checked for freedom of movement. Connections of all bases should be checked between the terminal connections and the contact plungers for continuity.

Insulation resistance test

8. The insulation resistance test between each terminal and the chassis should be measured using a 500V insulation resistance tester, the reading obtained should be not less than 5 megohms.

This file was downloaded
from the RTFM Library.
Link: www.scottbouch.com/rtfm

Please see site for usage terms,
and more aircraft documents.

