

Chapter 2

FLOATATION COT LAMP MK. 1

LIST OF CONTENTS

	Para.		Para.
<i>Introduction</i>	1	<i>Instructions for use</i>	5
Description	2	Servicing	6

LIST OF ILLUSTRATIONS

	Fig.		Fig.
<i>Lamp, with inset showing location on cot</i>	1	<i>Dismantled lamp housing, with inset showing fixing to cot</i>	2

LEADING PARTICULARS

Floatation cot lamp Mk. 1	Ref. No. 5A/4416
<i>Weight</i>	50 gms.
<i>Voltage of cell</i>	1.5 volts
<i>Dimensions of cell</i>	$2\frac{5}{8} \times 1\frac{1}{4} \times \frac{3}{8}$ in.
<i>Duration of discharge</i>	20 hours minimum
<i>Rating of lamp</i>	1.5 volts, 0.165 watt, 0.11 amp.

Introduction

1. The floatation cot lamp Mk. 1, is intended for use in baby's floating survival cots. Its purpose is to indicate the position of the cot when floating on the water at night. The lamp lights immediately the cot is lowered in to the water and remains alight for a minimum of 20 hours.

DESCRIPTION

2. The floatation cot lamp Mk. 1 (*fig. 1*), comprises a lamp housing connected by a 20-in. length of twin P.V.C. covered flexible cable to a water activated cell. The lamp is situated on the top of the cot, being mounted in the centre of the canopy arch support tube, whilst the water-activated cell is located below the water line on the outside of the cot.

3. The 1.5 volts cell is of the unsealed water type, which is activated automatically on immersion in salt or fresh water. The water enters the cell through two holes, which run

through the length of the case, thus forming the electrolyte to the silver chloride and magnesium plates, and activating the cell. The life of the cell with a 1.5 volts, 0.165 watt lamp load is nominally 20 hours, but an extra one or two hours of life at decreasing brilliance level may be expected. The cell is contained in an elastic holder located at the head of the cot.

4. The lamp housing comprises a filament lamp and a polythene lamp holder, enclosed in a transparent plastic dome (*fig. 2*). The housing is stitched to a fabric patch, and secured by adhesive to the arch support tube of the cot. With the cot inflated, and the canopy fastened in place, the plastic dome projects through a rubber aperture in the canopy.

Instructions for use

5. The cell is normally stowed in its elastic holder when the cot is folded and retained in its valise, thus once the cot is inflated, no

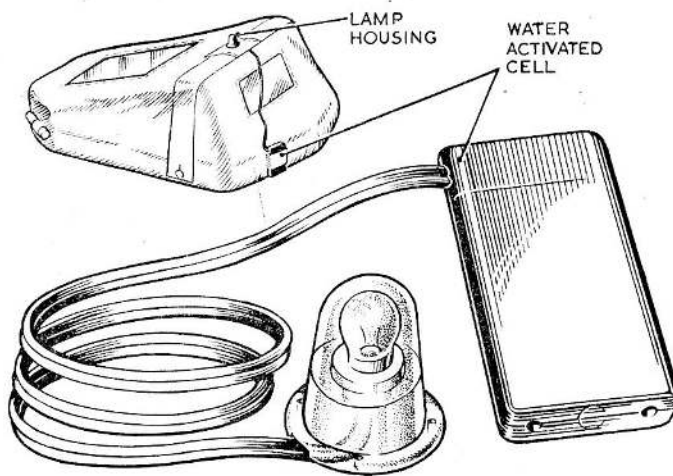

Fig. 1. Lamp, with inset showing location on cot

special steps need be taken to light the lamp (apart from ensuring the cell is securely retained in its elastic holder) as the light will automatically come on when the cot is lowered into the water.

SERVICING

6. At prescribed servicing periods the floatation cot lamp should be subjected to the following tests:—

(1) The cell can only be checked visually.

This is done by holding a source of light below the holes in the base of the case and looking through the holes in the top of the case. It should be possible to see right through the cell, and any obstruction will indicate deterioration. Where a cell shows signs of deterioration the whole lamp should be renewed.

(2) The lamp housing is normally fixed to the arch support tube by four stitches,

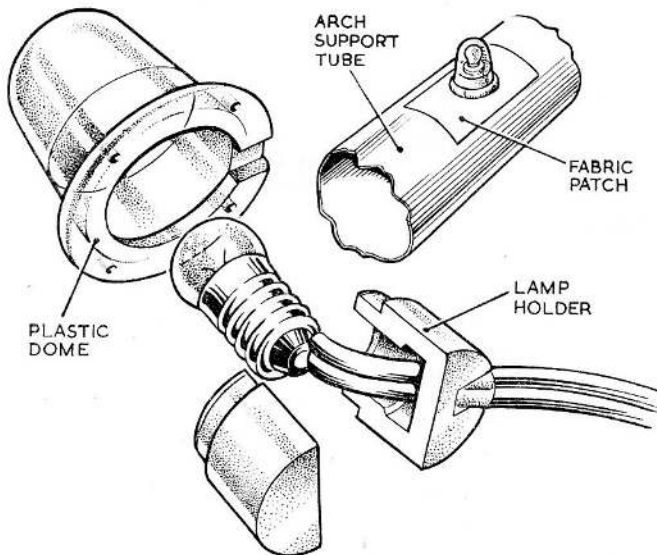

Fig. 2. Dismantled Lamp housing, with inset showing fixing to cot

RESTRICTED

and to test the filament lamp without removing the housing from the cot and taking it apart, a test prod will be required. The Memurdo aqualite test prod or an improvised test prod, whose function is to make electrical connection with the wiring by pushing two sharp contacts into the plastic covered cable, can be used. With a 1.5 volts supply connected to the test prod leads, the lamp should light. If the filament lamp is found to be faulty a new one can be fitted by dismantling the

lamp housing and soldering a new lamp to the ends of the cable.

Note . . .

To remove the lamp housing from the cot, the adhesive patch securing it to the arch support tube must first be peeled off. The four stitches can then be cut and the lamp housing dismantled. When replacing, the lamp housing must first be stitched to the patch before the patch is stuck to the arch tube.

This file was downloaded
from the RTFM Library.

Link: www.scottbouch.com/rtfm

Please see site for usage terms,
and more aircraft documents.



LIGHTNING MK. 1
COVER PITOT HEAD
EB2-88-5111