

## Chapter 18

INDICATORS, ELECTRO-MAGNETIC, TWO-POSITION,  
DOWTY, 5165Y AND 1245Z

## LIST OF CONTENTS

	<i>Para.</i>		<i>Para.</i>
<i>Introduction</i> ... ..	1	<i>Ball and armature assembly</i> ... ..	5
<b>Description</b>		<b>Operation</b> ... ..	6
<i>General</i> ... ..	3	<b>Installation</b> ... ..	7
<i>Magnet assembly and terminal block</i> ...	4	<b>Servicing</b> ... ..	9

## LIST OF ILLUSTRATIONS

	<i>Fig.</i>
<i>Sectional views of 5165Y indicator</i> ...	1
<i>Installation diagram</i> ... ..	2
<i>Sectional views of 1245Z indicator</i> ...	3

## LIST OF APPENDICES

	<i>App.</i>
<i>Details of markings</i> ... ..	1

## LEADING PARTICULARS

<i>Normal operating voltage (see note at end of Appendix 1)</i> ... ..	28V d.c.
<i>Minimum operating voltage</i> ... ..	16V d.c.
<i>Coil resistance</i> ... ..	461—12 ohms at 20 deg. C.
<i>Ambient temperature range</i>	
<i>Not energized</i> ... ..	—65 to +90 deg. C.
<i>Energized</i> ... ..	—65 to +70 deg. C.

RESTRICTED

## Introduction

1. The Dowty types 5165Y and 1245Z magnetic indicators are similar in construction and identical in markings, the improved construction of the 1245Z indicator being able to withstand ambient temperatures of  $-65$  to  $+70$  deg. C. (coil energized) and of accelerations up to 9g. This means that in all applications the 1245Z indicator can be used as a direct replacement for the 5165Y indicator, but the converse is true only where the extended temperature range and the 9g acceleration requirement need not be met.

2. These electro-magnetic indicators are used in various aircraft electrical circuits to give a visual indication as to the state of the circuit, i.e. whether energized or unenergized. The various indicator mark numbers are electrically identical and vary only in the markings on the indicator ball. Details of the markings of the individual indicators are given in Appendix 1 to this chapter.

## DESCRIPTION

### General

3. Sectional views of the Dowty two-position indicator are shown in fig. 1; fig. 2 is an installation diagram and shows the indicator mounted in a thin panel. A retaining spring fits over the indicator body between the panel and a bayonet type fixing ring. A location spigot on the top end of the indicator body fits in a cutaway in the panel to prevent the indicator rotating.

### Magnet assembly and terminal block

4. The magnet assembly inside the body consists of a coil wound on a soft iron core with a soft iron disc at the lower end of the coil to complete the magnetic circuit. The coil ends are soldered to terminals on a terminal block at the bottom end of the coil with 6 B.A. screws in the terminal block for the external electrical connections. The terminal block is held in position by a nut on the end of the core and the coil leads are insulated from the body by cellulose insulating tape. The indicator ball and its bearings

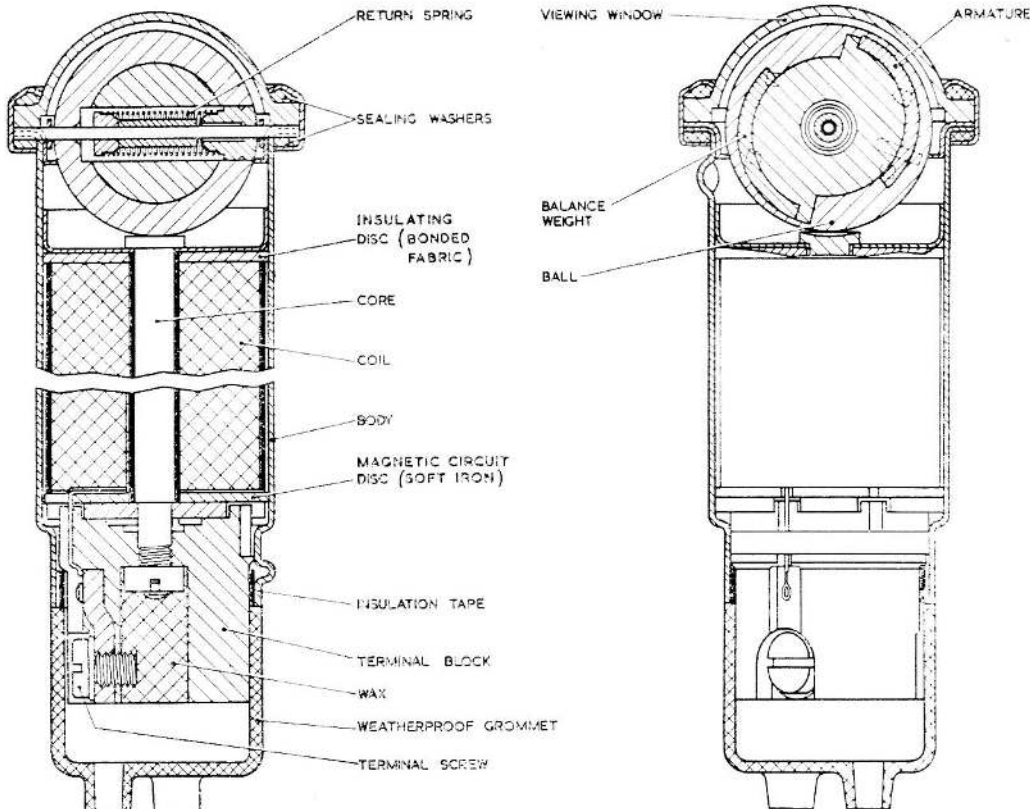

Fig. 1. Sectional views of 5165Y indicator

RESTRICTED

are housed in a sealed compartment formed by the window and the sealing round the top of the solenoid coil. The weather proofing of the electrical connections is obtained by a synthetic rubber grommet which fits over the extreme end of the terminal block; this grommet has three cable entry sleeves only two of which are used.

#### Ball and armature assembly

5. A plastic ball, with an armature and balance weight moulded in it, pivots on a spindle which has both ends welded to the indicator body. A coiled spring fits over the spindle inside the ball, one end of the spring being attached to the ball and the other to the spindle.

#### OPERATION

6. When the coil is energized, the armature is attracted to the magnet assembly and the ball revolves against the action of the spring. When the coil is de-energized, the ball returns to its original position under the influence of

the spring. In this manner, one portion of the ball is shown through the viewing window when the coil is de-energized and another portion shown when the coil is energized.

#### INSTALLATION

7. An installation diagram is shown in fig. 2 and illustrates the method of attaching the indicator to the panel. The panel cutaway should be as shown with the keyway at the top for vertical or sloping panels. The panel aperture should be as shown, with the cutaway at the top for vertical or sloping panels; in horizontal panels, the cutaway should be towards the edge of the panel furthest from the viewer.

8. If it is desired to fit the indicator from the front of the panel, the following procedure should be adopted:—

- (1) Slip the bayonet type fixing ring and spring over the leads.

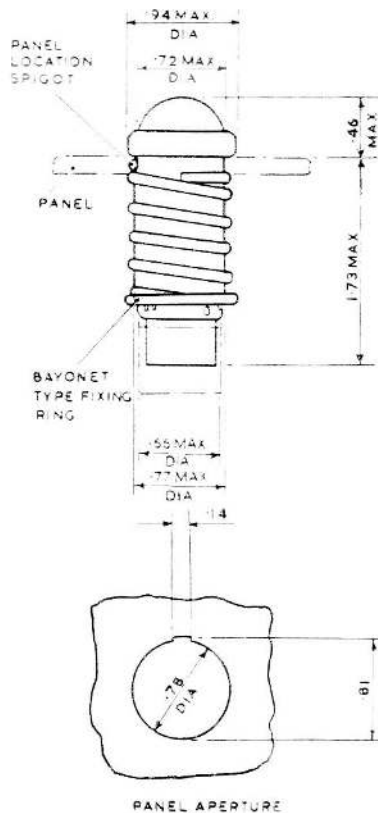

Fig. 2. Installation diagram

RESTRICTED

- (2) Bring the leads out through the panel.
- (3) Slip the rubber grommet over the leads and attach the leads to the indicator terminals.
- (4) Fit the rubber grommet over the terminals.
- (5) Pass the indicator back through the panel and secure the bayonet type ring and spring as shown, making sure that the locating spigot is in the cutaway.

## SERVICING

9. Ensure that the indicator is held securely in position. Check the unit for mechanical damage and fit a new one if necessary. If an indicator fails to operate, it must be removed and a serviceable one fitted in its place. Check that the fluorescent brightness of the white surface is satisfactory. This can be done by observing that it is clearly visible in dark surroundings. This test requires an ultra-violet lamp.

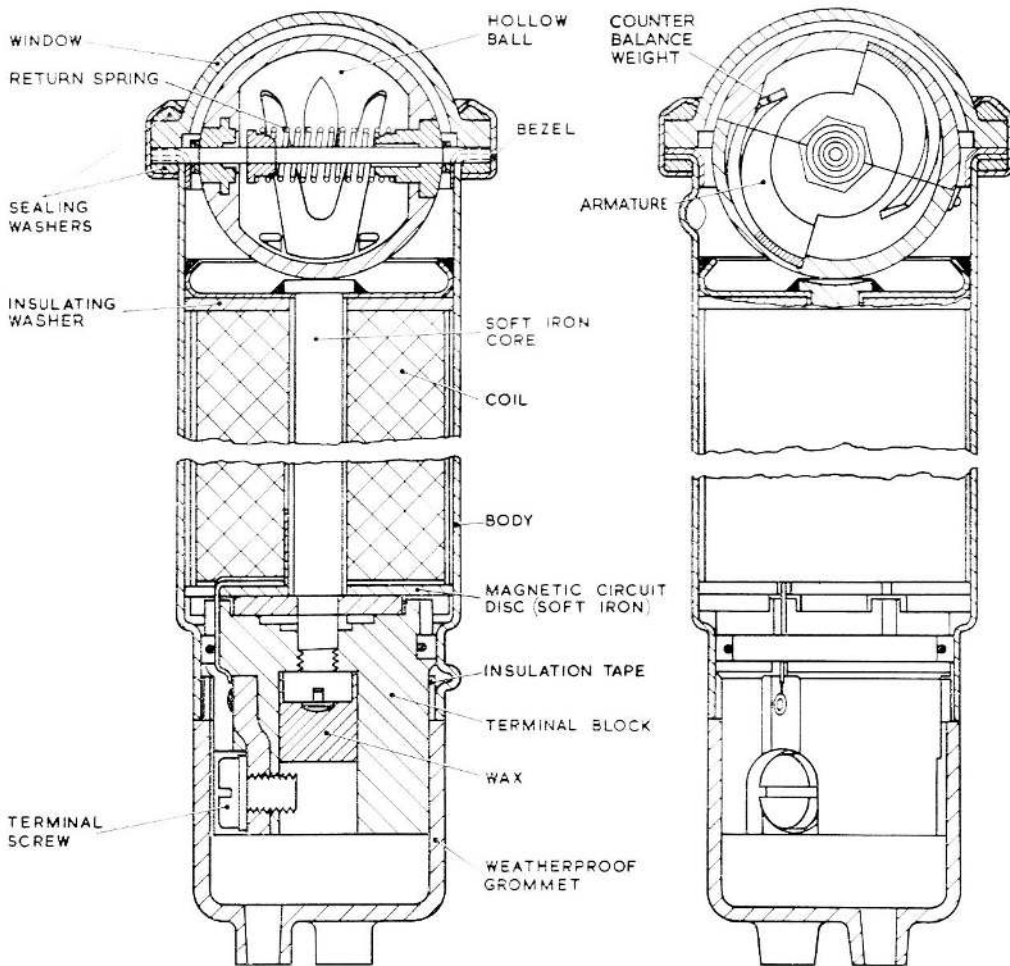

Fig. 3. Sectional views of 1245Z indicator

RESTRICTED



## Appendix 1

## DETAILS OF MARKINGS

Dowty 1245Z 5165Y Mk. No.	1245Z Ref. No. 5CZ/	5165Y Ref. No. 5CZ/	Indication	
			De-energized condition	Energized condition
1*		5073	} Black	Fluorescent white
P1		5958		
1P		7199		
2*		5074	} Fluorescent white	Black
P2		5959		
2P		6892		
3		5285	} Vertical white stripe on black background	Horizontal white stripe on black background
3P		6597		
4		5692	} Black	" ON " in black on white background
4P		6920		
5		5858	} Black	White
5P				
6		5693	} Black	" E " in black on white background
6P				
7		5210	} Horizontal fluorescent white stripe on black background	Vertical fluorescent white stripe on black background
7P				
8			} " F " in white on black background	" E " in red on white background
8P				
9		5964	} Black	" OPEN " in black on white background
9P				
10		6921	} " OFF " in black letters on fluorescent white background	" ON " in fluorescent white on black background
10P				
11			} " OPEN " in black on fluorescent white background	" SHUT " in fluorescent white on black background
11P				
12			} Fluorescent white	" T/OFF " in fluorescent white on black background
12P				
13		6127	} " OUT " in black on fluorescent white background	" IN " in fluorescent white on black background
13P				
14*		5003	} Black	Vertical fluorescent white stripe on black background
P14		6256		
14P				



RESTRICTED

**DETAILS OF MARKINGS (Contd.)**

Dowty 1245Z 5165Y Mk. No.	1245Z Ref. No. 5CZ/	5165Y Ref. No. 5CZ/	Indication	
			De-energized condition	Energized condition
15 15P			} " EMER " in black on fluorescent white background	" NORM " in fluorescent white on black background
16 16P	5503		} " NORM " in fluorescent white on black background	" LOW " in black on fluorescent white background
17 17P			} Fluorescent red	" ON " in fluorescent green on white background
18 18P	5965		} Black	" SHUT " in black on white background
19 19P	5694		} Black	" OV " in black on white background
20 20P			} " H " in white on black background	" L " in white on black background
21 21P	5697		} Black	" C/O " in black on white background
22 22P	5652		} " T/OFF " in fluorescent white on black background	Fluorescent white
23 23P	5292		} " OFF " in fluorescent white on black background	" ON " in fluorescent white on black background
24 24P			} White horizontal  on black background	White vertical  on black background
25 25P			} Red	" ON " in green on white background
26 26P			} Black	" LS " in black on fluorescent white background
27 27P			} Black	" AP " in black on fluorescent white background
28 28P			} Black	" AS " in black on fluorescent white background
29 29P	5750		} Black	" T " in fluorescent white on black background
30 30P	5751		} Black	" G " in fluorescent white on black background
31 31P			} Black	" INT " in black on white background

**RESTRICTED**

**DETAILS OF MARKINGS (Contd.)**

Dowty 1245Z 5165Y Mk. No.	1245Z Ref. No. 5CZ/	5165Y Ref. No. 5CZ	Indication	
			De-energized condition	Energized condition
32 32P			White vertical background  on black	White horizontal black background  on
33 33P	7248 7656	5859 7138	} Black	Vertical white stripe on black background
34 34P		6533 6598	} " OFF " in black on white background	" ON " in white on black background
35 35P		6599	} Black	" INT " in white on black background
36 36P		6128	} " DOWN " in white on black background	" UP " in black on white background
37 37P			} " OFF " in white on black background	" ON " in white on black background
38 38P			} " ON " in white on black background	" OFF " in white on black background
39 39P		6367	} " OUT " in black on white background	Black
40 40P		5960	} Black	" FULL " in black on white background
41 41P		5750	} Black	" T " in fluorescent white on black background
42 42P			} Black	" G " in fluorescent white on black background
43 43P			} " ON " in fluorescent white on black background	" OFF " in fluorescent white on black background
44 P44 44P		5751 6257	} Vertical fluorescent white stripe on black background	Black
45 45P		6129	} " DOWN " in black on white background	" UP " in white on black background

**RESTRICTED**

**DETAILS OF MARKINGS (Contd.)**

Dowty 1245Z 5165Y Mk. No.	1245Z Ref. No. 5CZ/	5165Y Ref. No. 5CZ/	Indication	
			De-energized condition	Energized condition
46 46P			} Green	Fluorescent red
47 47P		6172 6804	} Vertical fluorescent white stripe on black background	Horizontal fluorescent white stripe on black background
48 48P		7313	} " OFF " in black on fluorescent white background	Black
49 49P		6369	} Black	" ICE " in black on white background
50 50P			} Vertical red stripe on white background	Horizontal red stripe on white background
51 51P			} Horizontal red stripe on white background	Vertical red stripe on white background
52 52P			} " SHUT " in red on white background	" OPEN " in red on white background
53 53P	6696	6109 7280	} Black	Diagonal white stripes on black background
54 54P			} " OFF " in green on white background	" ON " in yellow on black background
55 55P			} Black	" N " in black on white background
56 56P			} Black	" O " in black on white background
57 57P			} White diagonal " T " on black background	White horizontal " T " on black background
58 58P			} " OFF " in white on black background	" FLOW " in white on black background
59 59P			} " SHUT " in white on black background	" OPEN " in white on black background
60 60P			} " FAIL " in black on white background	Black
61 61P			} " MM2 " in white on black background	" MMI " in white on black background
62 62P	6697	6951 7119	} 45° diagonal white stripes on black background	Black

**RESTRICTED**

## DETAILS OF MARKINGS (Contd.)

Dowty 1245Z 5165Y Mk. No.	1245Z Ref. No. 5CZ/	5165Y Ref. No. 5CZ/	Indication	
			De-energized condition	Energized condition
63 63P			} " E " in white on black background	" OUT " in black on white background
64 64P			} " ADF1 " in black on white background	" VOR1 " in black on white background
65 65P			} " ADF2 " in black on white background	" VOR2 " in black on white background
66 66P			} " VOR " in black on white background	" ILS " in black on white background
67 67P			} " N " in black on fluorescent white background	Black
68 68P			} " O " in black on fluorescent white background	Black
69 69P			} " COMP " in white on black background	" DG " in white on black background
70 70P			} Black	" BEAM " in black on white background
71 71P			} Black	" GP " in black on white background
72 72P			} Black	Two diagonal black stripes on (fluorink) orange " M " background
73 73P			} White	Black
74 74P			} Two black diagonal stripes on (fluorink) orange " M " background	Black
75 75P			} " OUT " in black on white background	" IN " in white on black background
76 76P			} " OFF " in white on black background	" FLOW " in black on white background

RESTRICTED

**DETAILS OF MARKINGS (Contd.)**

Dowty 1245Z 5165Y Mk. No.	1245Z Ref. No. 5CZ/	5165Y Ref. No. 5CZ/	Indication	
			De-energized condition	Energized condition
77 77P			} " SHUT " in white on black background	" OPEN " in black on white background
78 78P			} " OFF " in black on white background	" ON " in white on black background
79 79P			} " SHUT " in black on white background	" OPEN " in white on black background
80 80P			} " IN " in white on black background	" OUT " in black on white background
81 81P			} Horizontal white stripe on black background	Vertical white stripe on black background
82 82P			} " AUS " in white on black background	" EIN " in white on black background
83 83P			} " UP " in white on black background	" DOWN " in white on black background
84 84P			} Vertical black stripe on white background	Horizontal black stripe on white background
85 85P			} Broad black vertical stripe on white background	Broad black horizontal stripe on white background
86 86P			} Black	" RDY " in black on white background
87 87P			} Light grey background	Yellow horizontal stripe on light grey background
88 88P			} Light grey background	Blue horizontal stripe on light grey background
89 89P			} " MAN " in white on black background	" AUTO " in black on white background
90 90P			} " COMP " in white on black background	" DG " in black on white background
91 91P			} " MAG " in white on black background	" TRUE " in black on white background
92 92P			} Black	" TRAN " in white on black background
93 93P			} White	" ALL " in white on black background

**RESTRICTED**

## DETAILS OF MARKINGS (Contd.)

Dowty 1245Z 5165Y Mk. No.	1245Z Ref. No. 5CZ/	5165Y Ref. No. 5CZ/	Indication	
			De-energized condition	Energized condition
94 94P			} "NORM" in black on white background	"FIRE" in red on white background
95 95P			} "OUT" in black on white background	"IN" in white on black background
96 96P			} Black	Black on white background
97 97P			} "OUT" in white on black background	"IN" in white on black background
98 98P			} White right angle, lower left, on black background	White right angle, upper left, on black background
99 99P			} Black	"IC" in black on white background
100 100P			} Black	"IAS" in black on white background
101 101P			} "MAG" in white on black background	"TRU" in black on white background
102 102P			} "TRAN" in white on black background	Black
103 103P			} Black	"YES" in white on black background
104 104P			} Black horizontal line on white background	Black vertical line on white background
105 105P			} "Ud" in white on black background	"Ind" in white on black background
106 106P			} "ON" in fluorescent white on black background	"OFF" in black on fluorescent white background
107 107P			} "ILS" in black on white background	"VOR" in black on white background

RESTRICTED

## DETAILS OF MARKINGS (Contd.)

Dowty 1245Z    1245Z 5165Y    Ref. No. Mk. No.    5CW/	5165Y Ref. No. 5CW/	Indication	
		De-energized condition	Energized condition
108 108P	}	"COMP" in black on white background	"D.G." in black on white background
109 109P			Red "L" (fluoring) ground
110 110P	}	Black	White (fluoring) background
111 111P			"ARROW" in (fluorink) white on black background
112 112P	}	"IN" in white on black background	"OUT" in white on black background
113 113P			
114 114P	}	Black diagonal line on white background	Black diagonal line on white background
			

### \*AIR MINISTRY TYPE INDICATORS

Dowty 5165Y Mk. No.	A.M. Type	Ref. No. 5CZ/
1	A2	5073
2	B2	5074
14	C1	5003

#### Note . . .

*Indicators with no suffix letter are for 28V d.c. systems, e.g. 5165 Y, Mk. 1.*

*Indicators with a suffix 'A' are for 12V. d.c. systems, e.g. 5165 Y, Mk. 1A.*

*Indicators with a suffix 'P' are for use on Plasteck lighting panels, e.g. 5165 Y, Mk. 1P.*

*Indicators, 1245Z are designed to operate at 9G.*

*Indicator Mark numbers may be followed by one, two, or even three suffix letters.*

## RESTRICTED

This file was downloaded  
from the RTFM Library.

Link: [www.scottbouch.com/rtfm](http://www.scottbouch.com/rtfm)

Please see site for usage terms,  
and more aircraft documents.

