

Chapter 4**UNDERCARRIAGE INDICATORS, DOWTY 1224Y SERIES****LIST OF CONTENTS**

	<i>Para.</i>		<i>Para.</i>
<i>Introduction</i>	1	Servicing	20
Description	2	<i>Lamp replacement</i>	21
<i>Operation</i>	12	<i>Resistance replacement</i>	23
<i>Electrical connections</i>	17	Testing	
Installation	18	<i>Functional test</i>	25
		<i>Insulation resistance test</i>	27

LIST OF ILLUSTRATIONS

	<i>Fig.</i>		<i>Fig.</i>
<i>General view of indicator</i>	1	<i>Circuit diagram; with plug and link</i>	5
<i>Internal view of indicator</i>	2	<i>Circuit diagram; with plug and resistor</i>	6
<i>Terminal view of indicator</i>	3	<i>Installation details</i>	7
<i>Circuit diagram; with terminals and resistor</i>	4		

LIST OF TABLES

	<i>Table</i>		<i>Table</i>
<i>Undercarriage indicators 1224Y, Mk. 1 to 15</i>	1	<i>Lamp housing sub-assembly</i>	3
<i>Body sub-assembly</i>	2	<i>Miscellaneous components</i>	4

LIST OF APPENDICES

	<i>App.</i>		<i>App.</i>
<i>Undercarriage indicator, Type D (1224Y, Mk. 5)</i>	1	<i>Undercarriage indicator, 1224Y, Mk. 12</i>	3
<i>Undercarriage indicator, Type D1 (1224Y, Mk. 8)</i>	2	<i>Undercarriage indicator, 1224Y, Mk. 15</i>	4

RESTRICTED

Introduction

1. The 1224Y undercarriage indicators provide visual indication of the aircraft's undercarriage position and the condition of the undercarriage locking mechanism by a display of coloured lights; a dimming device prevents glare during night flying, and a switch is included to bring into use a reserve set of "LOCKED DOWN" lamps in the event of a filament failure.

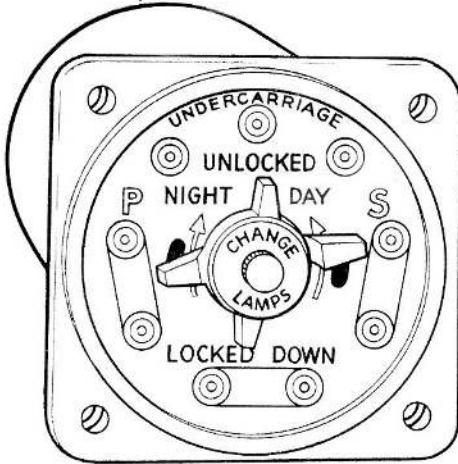

Fig. 1. General view of indicator

DESCRIPTION

2. The indicator is fitted with coloured windows and filament lamps; red to indicate that the undercarriage is unlocked and green to indicate that the undercarriage is in the locked down position. When the undercarriage is in the "LOCKED UP" position, all lights are switched off.

3. Fig. 1 shows the indicator with the change lever in the normal daytime position; operation of the lever to the night position brings into use a filter or dimming screen.

4. The indicator (fig. 1) which is housed in a miniature S.A.E. case, comprises two main assemblies, the body, which forms the case, and the lamp housing which also carries the indicator face.

5. The body of the indicator carries nine spring-loaded plunger-type contacts (fig. 2), one for the centre contact of each lamp, the fixed part of each plunger contact continuing through the rear portion of the moulding to receive the external electrical connections; the body also houses the ball indexed mechanism which provides the change over switching to the alternative lamps for the undercarriage indicator. In certain mark numbers of indicators, a protective resistance is fitted in the lamp circuit to minimise the risk of lamp failure.

6. The lamp housing, sometimes known as the spider, is removable from the front of the mounting panel; it is secured by a single central screw and houses the full set of nine lamps, together with the dimming device which also has an indexing action. The indicator face, which forms part of the lamp housing, carries three circular red windows, three long green windows, a winged knob for lamp changeover and a similar knob for dimming screen selection. The lamps are contained in cylindrical cells, the fronts of which coincide with the light windows in the front dial of the instrument. A conductor in the form of a helix, provides a common

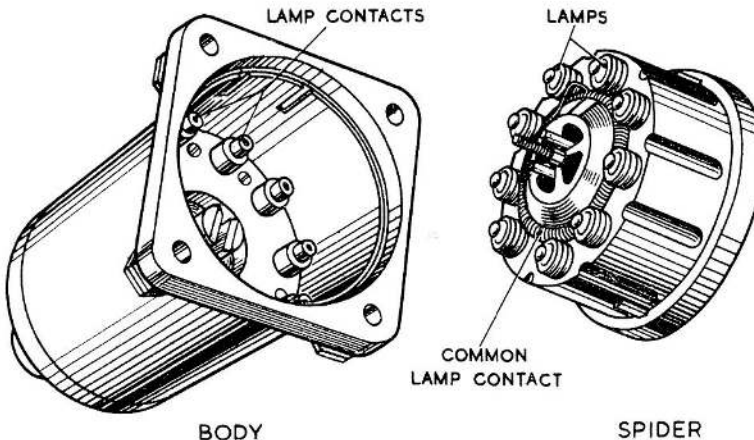

Fig. 2. Internal view of indicator

RESTRICTED

contact for all the lamps and also serves to hold the lamps within the cells; this arrangement allows the lamps to be readily withdrawn for examination or renewal.

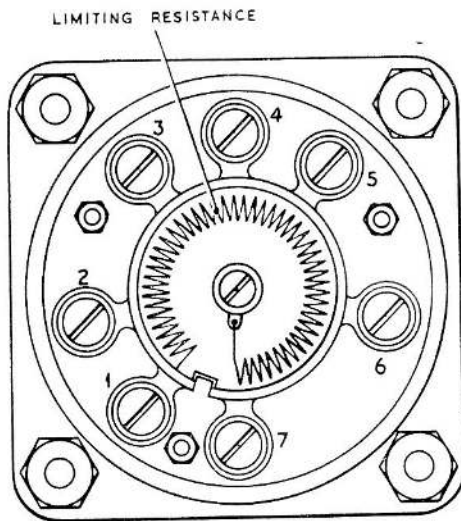

Fig. 3. Terminal view of indicator

7. Two types of indicators are available, depending on the type of lamps fitted to them. Certain mark numbers are supplied with a 15 ohm limiting resistance to permit the use of the older type 28V d.c. 3.5W lamp, Ref. No. 5L/9951272. Where an indicator is fitted with 28V d.c., 2.5W lamp Ref. No. 5L/9951286 the 15 ohm resistance is replaced by a link.

8. When the 15 ohm resistance is fitted to an indicator, it is fitted in series with the filament lamps and is connected between terminal 1 and the common centre contact (fig. 3) and is housed within the cylindrical recess at the rear end of the unit.

9. This resistance, when fitted in the lamp circuit serves useful purposes, as follows:—

- (1) To reduce the power consumption under normal running conditions to a value which, under tropical conditions, is not likely to result in undue heating of the colour windows and night screens.
- (2) To effect a voltage drop; producing

a resultant voltage slightly below 28V d.c.; with a corresponding reduction in lamp glare.

10. The arrangement of the three slots over the windows for the "LOCKED DOWN" position is such, that two lamps are located behind each of the slots. One lamp in each pair is spare and is only brought into use by operation of the vertical switch lugs located at the centre of the dial.

11. On operation of the change lever at the centre of the dial to the night position, the dimming screen obscures the "locked down" windows completely; this switch has its lugs in the horizontal position. The small knurled knob in the centre of the dial is used to secure the lamp assembly within the indicator case.

Operation

12. With the aircraft on the ground and the undercarriage "LOCKED DOWN", one set of three lamps in the lower section of the indicator illuminates the 'PORT', 'NOSE' and 'STARBOARD' green windows.

13. When the aircraft has taken off and the undercarriage has been selected up, as soon as it becomes unlocked, the green lights are extinguished, and the lamps in the upper part of the indicator illuminate the 'PORT', 'NOSE' and 'STARBOARD' red windows.

14. When the undercarriage is fully retracted and locked, all lamps are extinguished.

15. The lamps indicating that the undercarriage is locked down are brought into operation by microswitches incorporated in the undercarriage mechanism, details of which are contained in the appropriate Aircraft Handbook.

16. Reserve lamps are only provided on the green signal and, should one of the operating lamps fail, the lamp changeover vertical lug should be turned to bring the reserve set into use. To select the dimming screen, the horizontal lug should be turned clockwise.

RESTRICTED

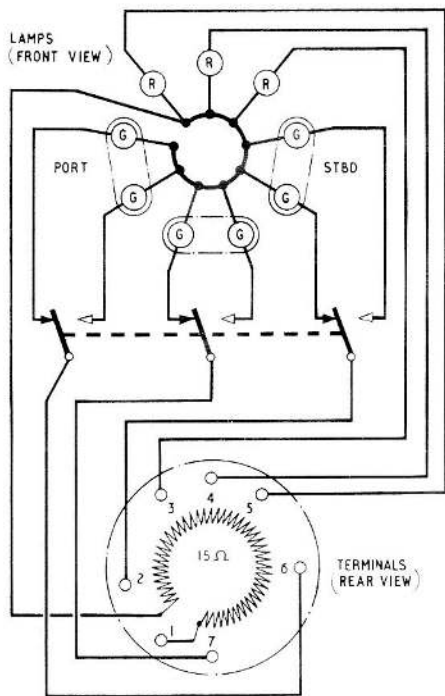

Fig. 4. Circuit diagram; with terminals and resistor

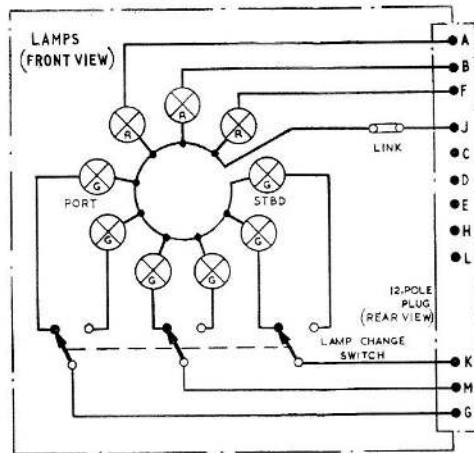

Fig. 6. Circuit diagram; with plug and resistor

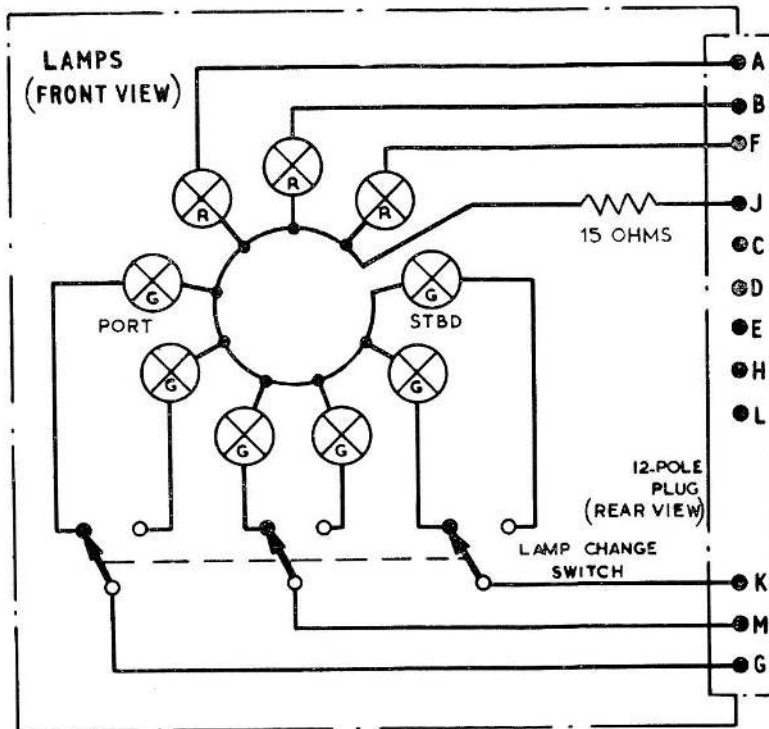

Fig. 5. Circuit diagram; with plug and link

RESTRICTED

Electrical connections

17. The external electrical connections are made in one of two ways, indicators marks 1 to 10 are fitted with terminal screws, protected by a terminal cover and a moulded neoprene cable entry weather proofing grommet, whilst indicators marks 11 to 20 are fitted with a shrouded connecting plug.

Note . . .

The removal of the plug protection cover from indicators marks 11 to 20 will result in damage to the unit, unless the multi-way plug is first freed by the removal of the fixing unit.

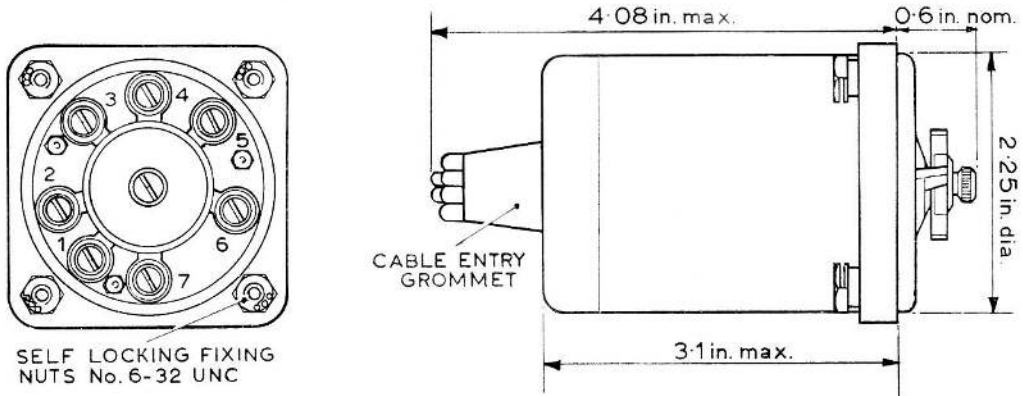

INDICATOR WITH TERMINAL SCREW ELECTRICAL CONNECTIONS

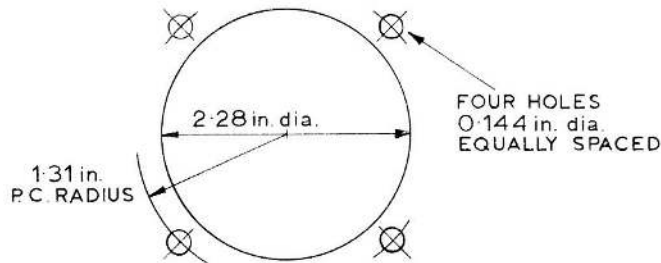

PANEL APERTURE AND DRILLING

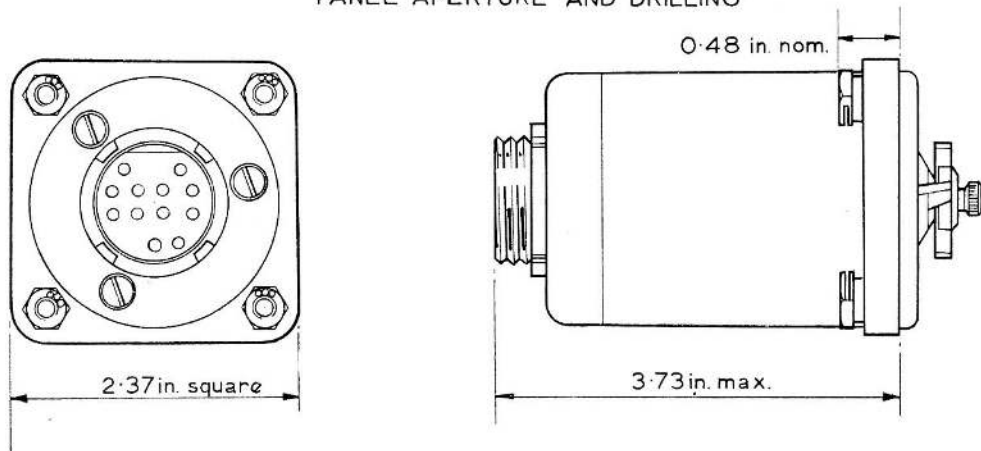

INDICATOR WITH PLUG CONNECTOR

Fig. 7. Installation details

RESTRICTED

INSTALLATION

18. The indicator mounting flange is fitted with four tapped bushes for securing the instrument to the pilot's instrument panel and will normally be mounted on the rear side of the panel, with the dial bezel fitting in an aperture in the panel. The indicator may, however, be mounted on the front of the panel by gently pressing out the tapped bushes in the flange, thereby providing clearance holes for the securing screws. Panel mounting details are shown in fig. 7.

19. To connect the 28V d.c. supply cables to the indicator terminals, remove the terminal cover on the rear of the casing. After removing the appropriate number of nipples from the cable grommet, pass the prepared cable leads through the grommet. Slight pressure on the grommet will invert it and permit the leads to be connected to the terminals. When connected, the cover may be secured and, by a slight pull on the cable, the grommet returned to its normal position, thereby taking up the slack of the connecting cables, within the terminal recess.

SERVICING

20. At the periods prescribed in the relevant Servicing Schedule, the indicator should be examined for security of electrical connections, mounting, deterioration of cables and signs of corrosion. Ensure that the waterproof seals under the terminal cover and dial are in a serviceable condition.

Note . . .

To avoid overheating, lamps rated in excess of 2.5 watts must not be used unless the indicator is fitted with a protective resistance; lamps used should be Ref. No. 5L/9951286.

Lamp replacement

21. The indicator which is supplied with a protective resistance should use 3.5 watt lamps Ref. No. 5L/9951272. The resistance is located in the rear part of the indicator body; the coiled common contact in the lamp housing is not the resistance.

22. To fit a new lamp, release the lamp housing by unscrewing the central knurled knob and remove the housing from the indicator body. The faulty lamp can now be withdrawn, as it has no further fastening. Servicing instructions should be followed regarding the frequency of lamp replacement,

as a guide, the anticipated life of a lamp is 500 hours. New lamps should be tested before and after fitting.

Resistance replacement

23. When replacing defective lamps, care should be taken to ensure that the keys on the lamp assembly engage with the keyways in the casing, under no circumstances must force be applied. Should any of the spring-loaded contacts in the casing (fig. 2) prove to be faulty, the indicator must be replaced by a serviceable unit.

24. Should the resistance be burnt out, remove the terminal cover and examine the interior of the indicator for signs of burning. Should it be necessary to replace the resistance, proceed as follows:—

- (1) Remove the central screw to free the insulating disc.
- (2) Remove the damaged resistance and destroy it.
- (3) Fit a new resistance, Dowty 1224Y 10 and a new disc, Dowty 1224Y 50.
- (4) After installing the resistance, examine the wiring and indicator external connections.

TESTING

Functional test

25. Before proceeding with a functional test, refer to the Aircraft Handbook for any precautions, other than jacking which may be necessary, e.g. the employment of ground locks.

26. Routine testing is considered unnecessary, since the indicator is used at each take-off and landing. However it is essential to perform a functional test after each repair or lamp removal, by making connections to individual terminals and noting that the correct lamps are illuminated, and that there are no defective lamps in the lamp assembly. The lamp change switch and night screen switch should also be tested for correct operation.

Insulation resistance test

27. Using a 250V d.c. insulation resistance tester Type C, or equivalent, measure the insulation resistance between all terminals and the frame; this reading should not be less than 5 megohms.

RESTRICTED

TABLE 1
Undercarriage indicators, 1224Y, Mk. 1 to 15

1224Y	Dial legend	Fitted with resistor or link	Filament lamp	Ref. No. 5CX/
Mk. 1	U/C and Tail	resistor	3.5W	
Mk. 2	U/C and nose	resistor	3.5W	
Mk. 3	U/C	resistor	3.5W	
Mk. 4	Floats	resistor	3.5W	
Mk. 5 (Type D)	U/C	resistor	3.5W	4204
Mk. 6	Swedish	resistor	3.5W	
Mk. 7	Finnish	resistor	3.5W	
Mk. 8 (Type D1)	U/C	link	2.5W	5164
Mk. 9	Finnish	resistor	3.5W	
Mk. 10	U/C (fluorescence lettering)	link	2.5W	
Mk. 11	U/C and tail	resistor	3.5W	
Mk. 12	U/C and nose	resistor	3.5W	
Mk. 13	U/C	resistor	3.5W	
Mk. 14	Floats	resistor	3.5W	
Mk. 15	U/C and nose	link	2.5W	5322

1. Tables 1, 2 and 3 detail the components fitted to each mark of indicator.

TABLE 2

Body sub-assembly		Indicator mark numbers 1224Y														
Ref. No.	1224Y	1	2	3	4	5	6	7	8	9	10	11	12	13	14	15
	84A	1	1	—	—	1	1	—	—	1	—	—	—	—	—	—
	84B	—	—	—	—	—	—	—	—	—	—	1	1	—	—	—
	84C	—	—	—	—	—	—	—	1	—	1	—	—	—	—	—
	84D	—	—	—	—	—	—	—	—	—	—	—	—	—	—	1
	84E	—	—	1	1	—	—	1	—	—	—	—	—	—	—	—
	84F	—	—	—	—	—	—	—	—	—	—	—	—	1	1	—

RESTRICTED

TABLE 3

Lamp housing sub-assembly		Indicator mark numbers 1224Y														
Ref. No.	1224Y	1	2	3	4	5	6	7	8	9	10	11	12	13	14	15
5CX/5299	86A	1	—	—	—	—	—	—	—	—	—	1	—	—	—	—
	86B	—	1	—	—	—	—	—	—	—	—	—	1	—	—	1
	86C	—	—	1	—	—	—	—	—	—	—	—	—	1	—	—
	86D	—	—	—	1	—	—	—	—	—	—	—	—	—	1	—
	86E	—	—	—	—	1	—	—	1	—	—	—	—	—	—	—
	86F	—	—	—	—	—	1	—	—	—	—	—	—	—	—	—
	86G	—	—	—	—	—	—	1	—	—	—	—	—	—	—	—
	86H	—	—	—	—	—	—	—	—	1	—	—	—	—	—	—
	86J	—	—	—	—	—	—	—	—	—	1	—	—	—	—	—

Note . . .

One body and one lamp housing form a complete indicator.

TABLE 4

Miscellaneous components

1224Y	Ref. No. 5CX/	Indicator mark numbers 1224Y														
		1	2	3	4	5	6	7	8	9	10	11	12	13	14	15
Instrument nut, 4 B.A.*	40	4	4	4	4	4	4	4	4	4	4	4	4	4	4	4
Instrument nut, 6-32 UN.C*	88	4	4	4	4	4	4	4	4	4	4	4	4	4	4	4
Terminal screw and washer	AGS1753-3B	7	7	5	5	7	7	5	7	7	7	7	7	5	5	7
Connecting link	79	5300	—	—	—	—	—	—	—	1	—	1	—	—	—	1
Screw for 1224Y-50 or 79	10000Z-23	1	1	1	1	1	1	1	1	1	1	1	1	1	1	1
Shakeproof washer for screw	AGS2035A	1	1	1	1	1	1	1	1	1	1	1	1	1	1	1
Resistor	10	1	1	1	1	1	1	1	—	1	—	1	1	1	1	—
Resistor retaining plate	50	1	1	1	1	1	1	1	—	1	—	1	1	1	1	—
Terminal cover (screw connections)	3	4549	1	1	1	1	1	1	1	1	1	—	—	—	—	—
Terminal cover (Plug connector)*	56	—	—	—	—	—	—	—	—	—	—	—	1	1	1	1
Plug connector locking key*	58	—	—	—	—	—	—	—	—	—	—	—	1	1	1	1
Plug connector and nut*	CZ49112	10H/ 19101	—	—	—	—	—	—	—	—	—	—	1	1	1	1

Note . . .

(1) *Units fitted with No. 6-32 UN.C fixing nuts are marked with a three-circles symbol (see fig. 6 and 7)*

*(2) *Terminal cover 1224Y-56 does not include the plug connector, or locking key.*

RESTRICTED

Appendix 1

LEADING PARTICULARS

<i>Undercarriage position indicator, Type D (1224Y, Mk. 5)</i>	<i>Ref. No. 5CX/4204</i>
<i>Dimensions of mounting flange (in.)</i>	$2\frac{3}{8} \times 2\frac{3}{8}$
<i>Weight</i>	8 oz.
<i>Filament lamp, 28V, 3.5W (9 off, fully equipped, or 6 off equipped for P and S only)</i>	<i>Ref. No. 5L/9951272</i>
<i>Electrical connections</i>	<i>Screw terminals</i>

1. The undercarriage indicator, Type D is a Dowty 1224Y indicator as described in the main chapter. It does however differ in some respects; these differences are enumerated below:—

(1) This indicator is fitted with the higher wattage filament lamps, this necessitates the fitting of a 15 ohm resistance in series with the lamps to prevent overheating and possible resultant lamp failure.

2. The description, operation, installation and servicing information given in the main chapter, apply directly to this indicator, except where reference is made to the link, or the 2.5 filament lamps. Information which applies particularly to this indicator is given under Leading Particulars. A circuit diagram of this indicator appears in fig. 4 of the main chapter.

Appendix 2

LEADING PARTICULARS

<i>Undercarriage position indicator, Type D1 (1224Y, Mk. 8)</i>	<i>Ref. No. 5CX/5164</i>
<i>Dimensions of mounting flange (in.)</i>	$2\frac{3}{8} \times 2\frac{3}{8}$
<i>Weight</i>	8 oz.
<i>Lamp filament, 28V, 2.5W (9 off, fully equipped, or 6 off, equipped for P and S only)</i>	<i>Ref. No. 5L/9951286</i>
<i>Electrical connections</i>	<i>Screw terminals</i>

1. The undercarriage indicator, Type D1 is a Dowty 1224Y indicator as described in the main chapter. It does however differ in some respects; these differences are enumerated below:—

(1) Due to the reduction in wattage of the filaments from 3.5 to 2.5 watts, the 15 ohm limiting, or protective resistance is replaced by a link.

2. The description, operation, installation and servicing information given in the main chapter, apply directly to this indicator, except where reference is made to the limiting resistance, or the 3.5 filament lamps. Information, which applies particularly to this indicator is given under Leading Particulars. A circuit diagram of this indicator is shown in fig. 4, except that the 15 ohm limiting resistance is replaced by a link.

RESTRICTED

Appendix 3

LEADING PARTICULARS

<i>Undercarriage indicator, Type 1224Y, Mk. 12</i>	<i>Ref. No. 5CX/</i>
<i>Dimensions of mounting flange</i>	$2\frac{3}{8} \times 2\frac{3}{8}$
<i>Weight</i>	8 oz.
<i>Filament lamps (9 off), 28V, 3.5W., M.E.S. cap</i>	<i>Ref. No. 5L/9951272</i>
<i>12-pole plug</i>	<i>Ref. No. 10H/19101</i>

1. The undercarriage indicator, Dowty Type 1224Y, Mk. 12 is similar to that described in the main chapter. It does however differ in several respects; these differences are enumerated below.

- (1) A 15 ohm resistance is fitted in series with the 3.5 watt lamps.
- (2) A 12-pole plug replaces screw terminals as electrical connections.

2. The description, operation, installation and servicing notes apply directly to this indicator. Information, which applies particularly to this unit, is given under Leading Particulars. A circuit diagram for this indicator is shown in fig. 5 of the main chapter.

Appendix 4

LEADING PARTICULARS

<i>Undercarriage indicator, Type 1224Y, Mk. 15</i>	...	<i>Ref. No. 5CX/5322</i>
<i>Dimensions of mounting flange</i>	$2\frac{3}{8} \times 2\frac{3}{8}$ in.
<i>Weight</i>	8 oz.
<i>Lamp filament, 28V, 2.5W (9 off)</i>	<i>Ref. No. 5L/9951286</i>
<i>12-pole plug</i>	<i>Ref. No. 10H/19101</i>

1. The undercarriage indicator, Dowty Type 1224Y, Mk. 15 is similar to that described in the main chapter. It does however differ in several respects; these differences are enumerated below:—

- (1) The 15 ohm resistance is replaced by a link.
- (2) The wattage of the filament lamps are reduced from 3.5 to 2.5 watts.
- (3) A 12-pole miniature plug replaces the screw terminals.

2. The description, operation, installation and servicing notes given in the main chapter, except where reference is made to the limiting resistor, terminal block, or the 3.5 watt filament lamps, apply to this indicator. Information which applies particularly to this unit is listed under Leading Particulars. A circuit diagram of this unit appears in fig. 6 of the main chapter.

RESTRICTED

This file was downloaded
from the RTFM Library.

Link: www.scottbouch.com/rtfm

Please see site for usage terms,
and more aircraft documents.

