

Chapter 60

INDICATOR UNIT, PAGE ENG., C6600

LIST OF CONTENTS

	<i>Para.</i>								<i>Para.</i>
<i>Introduction</i>	1	<i>Switches</i>							5
Description	3	<i>Operation</i>							6
<i>Indicator lamps</i>	4	Servicing							8

LIST OF ILLUSTRATIONS

						<i>Fig.</i>
<i>Indicator Unit, Type C6600 (front and rear view)</i>						1
<i>Circuit diagram</i>						2

LIST OF APPENDICES

						<i>App.</i>
<i>Standard serviceability test for Indicator Unit, Page Eng. C6600</i>						A

LEADING PARTICULARS

<i>Indicator Unit, Type C6600</i>	<i>Ref. No.</i> 5CZ/
<i>Voltage</i>	28V d.c.
<i>Lamp, midget flange A259 (36 off)</i>	<i>Ref. No.</i> 5L/9959118
<i>Test push switch, C183</i>	<i>Ref. No.</i> 5CW/6402
<i>Ground test switch C676/F20</i>	<i>Ref. No.</i> 5CW/
<i>Cancel switch C180/A1</i>	<i>Ref. No.</i> 5CW/6400
<i>Mute switch C181/A2</i>	<i>Ref. No.</i> 5CW/6401
<i>Fire switches (2 off) C180/A3</i>	<i>Ref. No.</i> 5CW/6403
<i>Overall dimensions (inches)</i>	5.13 x 5.13 x 3.53
<i>Weight</i> 2.156 lb.

Introduction

1. The indicator unit Type C6600 is used in conjunction with the flasher and excitation unit Type C6640 to make the centralized warning system for the Buccaneer S Mk. II.

2. The Standard centralized warning system is described in A.P.4343, Vol. 1, Sect. 23, Chap. 4 which includes the introduction of the transistorized system.

RESTRICTED

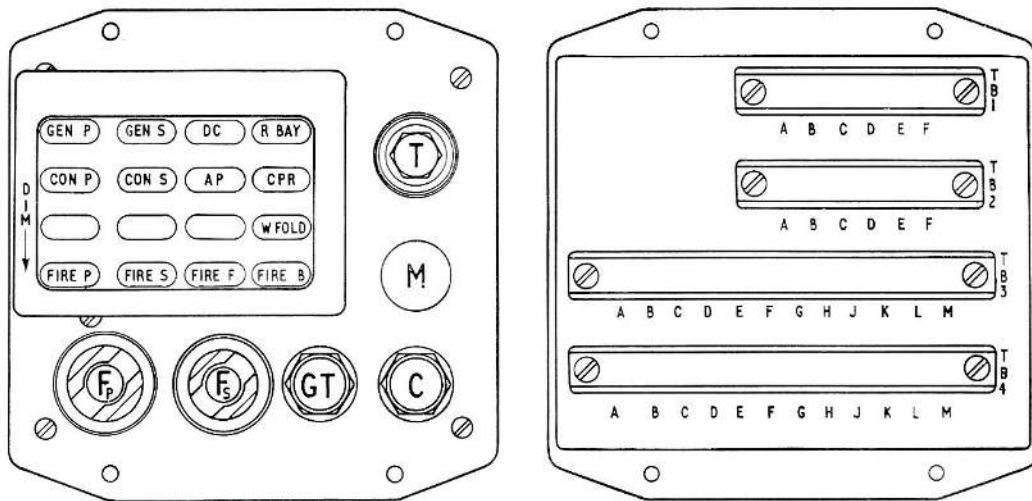

Fig. 1. Indicator Unit, Type C6600 (front and rear view)

DESCRIPTION

3. The C6600 unit groups, on one indicator panel, the appropriate warning lamps for the aircraft as shown in fig. 1. A hinged caption plate is fitted over the lamps, the appropriate caption being illuminated by the lamp when a fault appears. Connection to the lamp and switches are made via four terminal blocks on the rear of the unit.

Indicator lamps

4. The indicator lamps are 28V .04A wired in pairs for each fault indication to allow for lamp failure. A 220 ohm resistor is connected in series with each wing fold lamp and the muting switch lamp to limit the current, as they may be illuminated for long periods while on the ground.

Switches

5. Information on the switches shown in fig. 2 is contained in A.P.4343C, Vol. 1, Book 1, Sect. 1, Chap. 25.

Operation

6. When any of the emergencies arise, the two filament lamps in the indicator panel illuminate the appropriate caption. Simul-

taneously the cancel switch C is fed from the flasher of the C6640 unit giving a pulsating signal to the filament lamp. By depressing the cancel switch the flasher is switched off and the cancel switch ceases to illuminate. If a fire occurs in the engine bay the appropriate push switch Fs or Fp will illuminate, when this switch is depressed the appropriate fire extinguisher operates.

7. A muting switch M is included to eliminate all warnings except fire or wing fold. When the circuit is muted the lamp of the mute switch is illuminated. A ground test switch GT is incorporated to facilitate testing when the aircraft is on the ground. A test switch T is included to facilitate testing of the indicator lamps.

SERVICING

8. Examine the unit for signs of damage, corrosion, security of attachment and electrical connections. To examine the filament lamps, hinge back the caption plate. To replace the lamps, release the quick release fasteners and remove the lamp panel assembly, the lamps can then be removed.

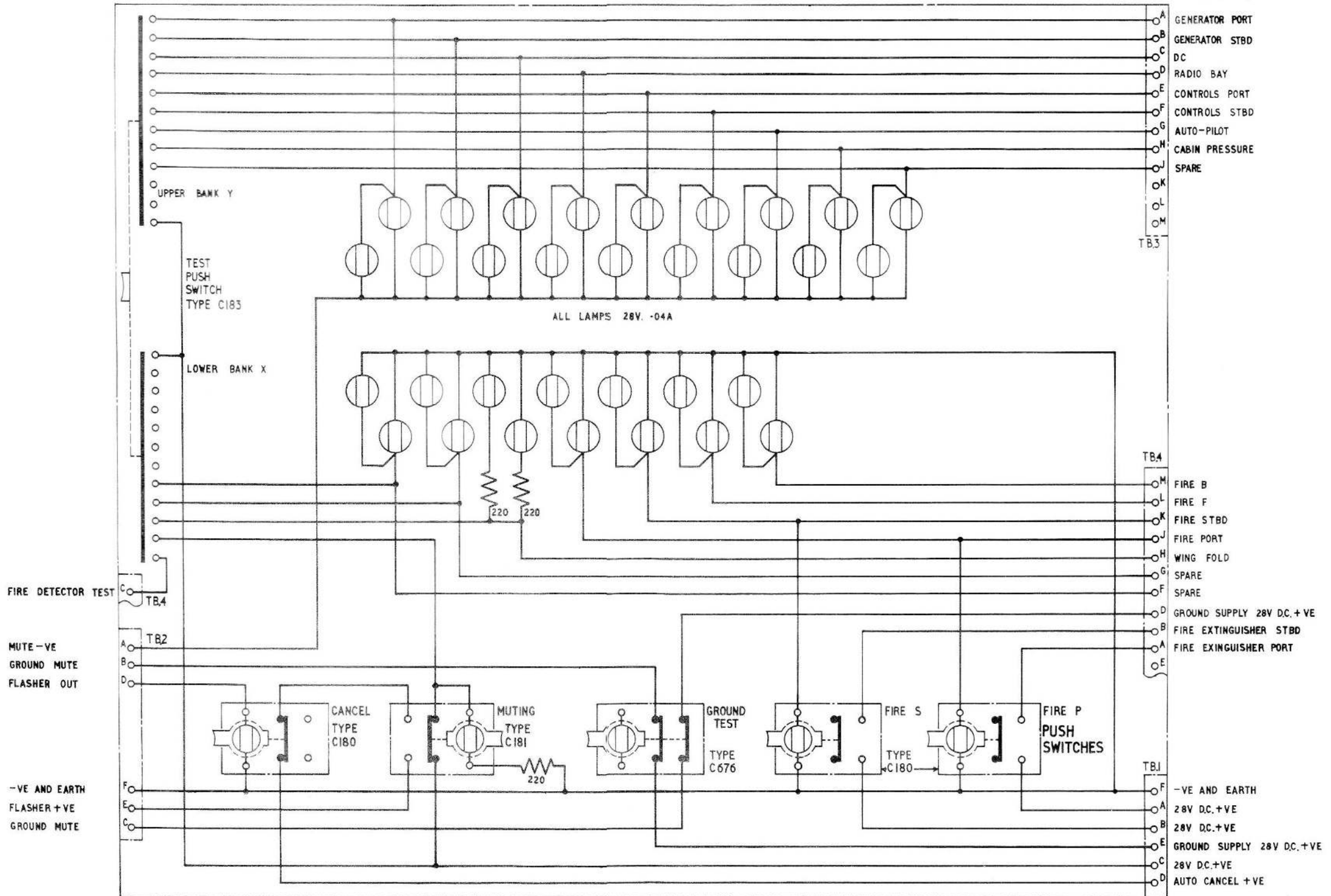

Fig. 2

Fig. 2

Circuit diagram
RESTRICTED

Appendix A

STANDARD SERVICEABILITY TESTS

for

INDICATOR UNIT, PAGE., C6600

Introduction

1. The following tests should be applied to the unit before installation, after servicing, or at any time when the serviceability of the unit is suspect.

Test equipment

2. The following test equipment is required:-

- (1) Insulation resistance tester Type C (Ref. No. 5G/152).
- (2) Four single pole 5 amp switches.
- (3) Five 28V 04A indicator lamps.

TESTING

Functional test

3. Connect the indicator to the test circuit as shown in fig. 1. Ensure that the mute switch M is in the normal position, i.e. unit not muted, and carry out the operations detailed in Table 1.

Insulation resistance test

4. When measured using a 250V insulation resistance tester type C, the insulation resistance between all terminals and frame should be not less than 0.5 megohm.

5. Any switches which are suspect should be tested in accordance with the details given in the appropriate chapter of A.P.4343C, Vol. 1, Book 1.

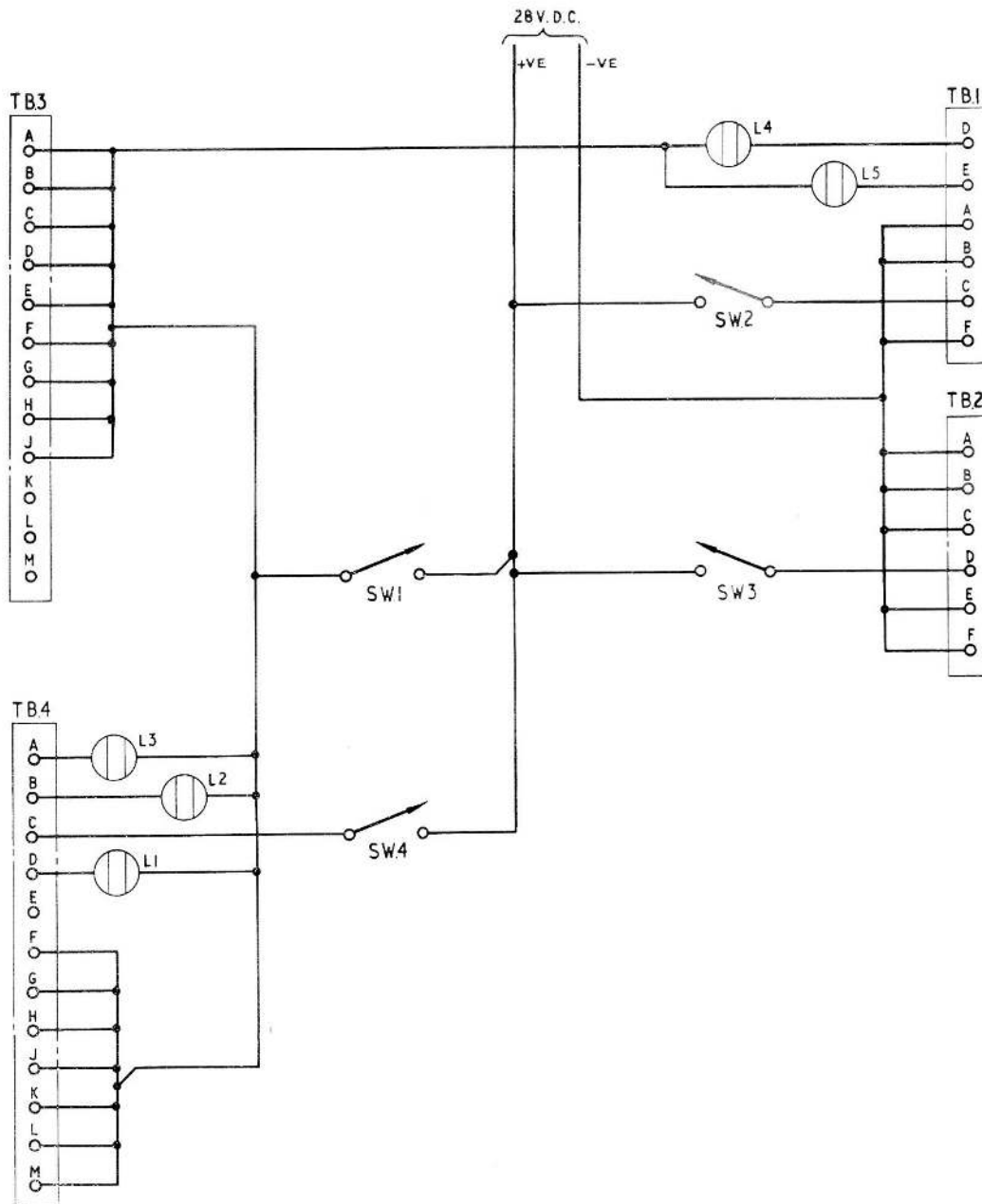

Fig. 1. Test Circuit Unit for Indicator Unit Type C6600

RESTRICTED

TABLE 1

Operation	SWITCH SETTINGS										EFFECT ON LAMPS (X = ON, — = OFF)									
	Test Equipment				Indicator Under Test						Test Circuit Lamps					Indicator Under Test				
	S1	S2	S3	S4	T	GT	M	C	FP	FS	L1	L2	L3	L4	L5	WARNING LAMPS	FP	FS	C	M
1	ON	—	—	—	—	—	—	—	—	X	—	—	X	X	X	X	X	—	—	
2	ON	—	—	—	—	—	—	PRESS	—	X	—	X	X	X	X	X	X	—	—	
3	ON	—	—	—	—	—	—	RELEASE	—	X	—	—	X	X	X	X	X	—	—	
4	ON	—	—	—	—	—	—	—	PRESS	X	X	—	X	X	X	X	X	—	—	
5	ON	—	—	—	—	—	—	—	RELEASE	X	—	—	X	X	X	X	X	—	—	
6	ON	—	—	—	—	—	—	PRESS	—	—	—	—	X	—	X	X	X	—	—	
7	ON	—	—	—	—	—	—	RELEASE	—	X	—	—	X	X	X	X	X	—	—	
8	ON	—	—	—	—	—	—	PRESS	—	X	—	—	—	X	X	X	X	—	—	
9	ON	—	—	—	—	—	—	RELEASE	—	X	—	—	X	X	X	X	X	—	—	
10	ON	—	—	—	—	—	—	PULL	—	X	—	—	—	X	X	X	X	—	—	
11	ON	—	—	—	—	—	—	PUSH	—	X	—	—	X	X	X	X	X	—	—	
12	—	—	—	—	—	—	—	—	—	—	—	—	—	—	—	—	—	—	—	
13	—	ON	—	—	—	—	—	—	—	—	—	—	—	—	—	—	—	—	—	
14	—	ON	—	—	—	—	—	PULL	—	—	—	—	—	—	—	—	—	—	X	
15	—	ON	—	—	—	—	—	PUSH	—	—	—	—	—	—	—	—	—	—	—	
16	—	ON	—	—	—	—	—	PRESS	—	X	—	—	X	X	X	X	X	—	X	
17	—	ON	—	—	—	—	—	RELEASE	—	—	—	—	—	—	—	—	—	—	—	
18	—	—	ON	—	—	—	—	—	—	—	—	—	—	—	—	—	—	X	—	
19	—	—	—	—	—	—	—	—	—	—	—	—	—	—	—	—	—	—	—	
20	—	—	—	ON	—	—	—	PRESS	—	X	—	—	X	X	X	X	X	—	X	
21	—	—	—	—	—	—	—	—	—	—	—	—	—	—	—	—	—	—	—	

RESTRICTED

This file was downloaded
from the RTFM Library.

Link: www.scottbouch.com/rtfm

Please see site for usage terms,
and more aircraft documents.

