

Chapter I

SOLENOID UNIT, ROTAX TYPE D8001

LIST OF CONTENTS

	Para.		Para.
Introduction	1	Installation	6
Description	2	Servicing	7
Electrical connections	4	Insulation resistance tests	9
Operation	5		

LIST OF ILLUSTRATIONS

	Fig.		Fig.
D8001 solenoid unit	1	Diagram of connections	2

LEADING PARTICULARS

Solenoid, D8001	Stores Ref. 5CW/4415
Voltage	112V, d.c.
Coil resistance (at 20 deg. C)	157 ohm.
Operating stroke of plunger	0.187 in.
Overall dimensions	
Length	4.782 in.
Diameter of body	2.594 in.
Width of base	3.25 in.
Height	3.75 in.
Weight	4 lb. 5 oz.

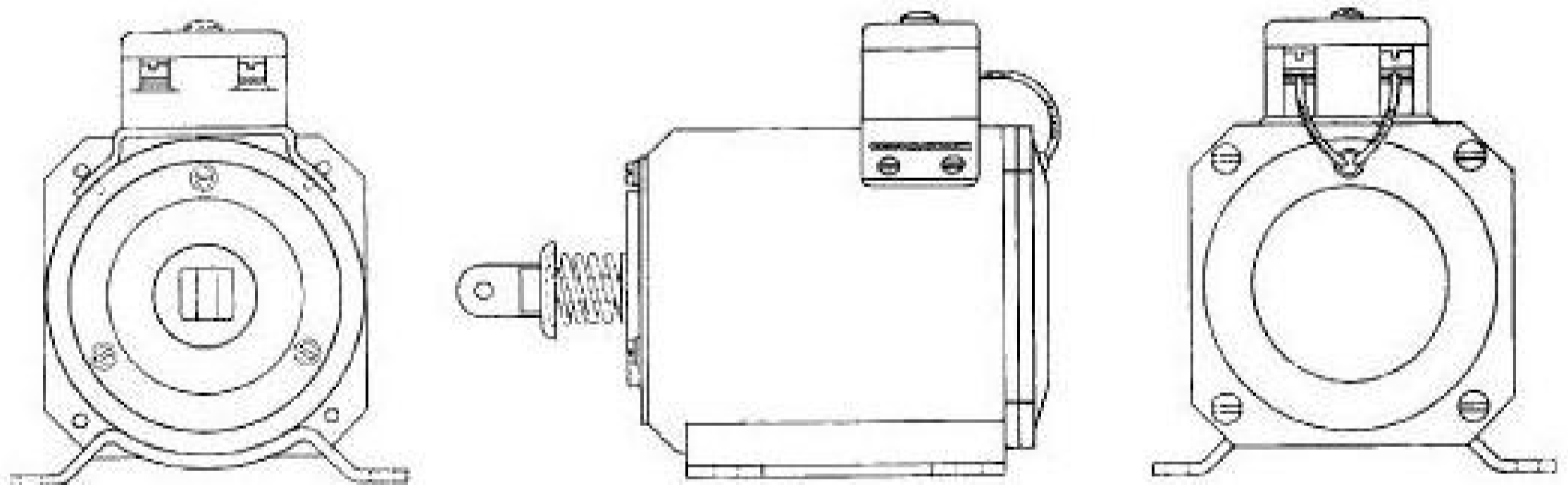

Fig. 1. D8001 solenoid unit

Introduction

1. This solenoid unit has been designed for the operation of aircraft ancillary equipment, such as a dog clutch, where a linear movement of 0.187 in. is required against a load of up to 13 lb. over a limited period.

DESCRIPTION

2. The unit consists of a solenoid coil fitted round a hollow cylindrical bobbin, an anvil,

the shaft of which is situated inside one end of the coil bobbin and a plunger assembly which fits into the other end of the coil bobbin. A conical recess is machined into the top of the anvil and the plunger is tapered to a cone at the end. The coil, bobbin, anvil and plunger assemblies are enclosed in a metal case which has a fixing bracket at one side and a terminal block mounted at the other side.

RESTRICTED

(A.L. 75, Aug. 55)

3. The anvil is secured to the outer casing by four 6 B.A. screws situated at its base. The connections between the coil and the terminal block pass through a hole, fitted with a grommet, in the base of the solenoid case. A plate is fixed to the plunger assembly and secured to the outer casing by three 6 B.A. screws. The plunger shaft is screwed into the plunger and is secured by a locking pin. A plunger return spring is fitted to the shaft of the plunger to ensure that the shaft is in the extended position when the coil is not energized. To facilitate mechanical connection between the unit and its load the end of the plunger shaft is shaped to receive a forked link.

Electrical connections

4. The connections on the 2-way terminal blocks are 4 B.A. combined screw and washer type connections.

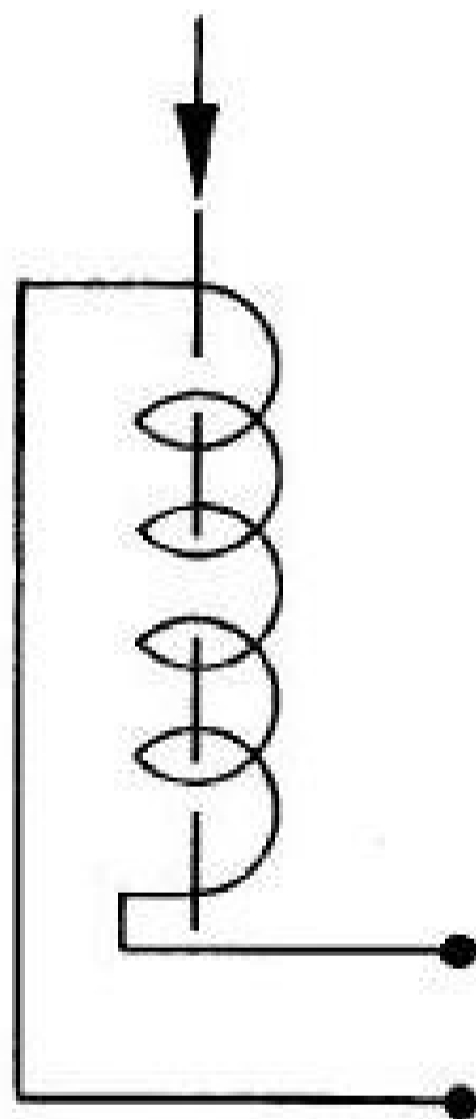

Fig. 2. Diagram of connections

Operation

5. When the solenoid is energized, the plunger is pulled in towards the anvil against the force of the loading on the shaft. The initial spring load is 12 lb. in the fully extended position and 17 lb. when the spring is fully compressed.

INSTALLATION

6. The unit may be mounted in any position. In the mounting base there are two holes and two rounded slots (the centres of which form a rectangle 2 in. by 2.850 in.). The two holes are 0.189 in. in diameter and the two slots, 0.250 in. by 0.187 in.

SERVICING

7. When the units have been correctly installed and operated, they require little attention in service. If a unit operates satisfactorily it may be assumed serviceable for continued use.

8. A visual inspection should be made periodically to ensure that the unit is not damaged physically. Inspect the plunger shaft and spring and if there is any sign of damage remove the unit and fit a new one in its place.

Insulation resistance tests

9. Insulation resistance tests should be applied to the unit provided that it is accessible and can be isolated from its circuit. With a 250 volt insulation resistance tester measure the resistance between the coil and the outer casing. This should not be less than 2 megohm.

Note . . .

The resistance value quoted in para. 9 applies to units being tested under normal workshop conditions. Allowance should be made for climatic conditions, in particular, humid climates. Under these conditions, resistance readings may be lower, and discretion should be exercised before rejecting units.

This file was downloaded
from the RTFM Library.

Link: www.scottbouch.com/rtfm

Please see site for usage terms,
and more aircraft documents.



**TELEBRIEF
CONNECTIONS**

E