

## Chapter 9

### WINDSCREEN DE-ICING CONTROLLER, PLESSEY TYPE 23

#### LIST OF CONTENTS

	<i>Para.</i>		<i>Para.</i>
<i>Introduction</i> ... ..	1	<i>Faults affecting both channels</i> ...	32
<b>Description</b> ... ..	3	<i>Faults affecting the control channel</i> ...	33
<b>Operation</b>		<i>Faults affecting the overheat channel</i>	37
<i>General</i> ... ..	6	<i>Repair</i> ... ..	40
<i>Control channel</i> ... ..	10	<i>Assembling</i> ... ..	47
<i>Overheat channel</i> ... ..	15	<i>Testing</i>	
<b>Installation</b> ... ..	19	<i>Preparation</i> ... ..	48
<b>Servicing</b> ... ..	20	<i>Control channel operating point</i> ...	50
<i>Tools and test equipment</i> ... ..	23	<i>Function tests</i> ... ..	51
<i>Dismantling</i> ... ..	24	<i>Relay contacts tests</i> ... ..	54
<i>Cleaning</i> ... ..	25	<i>Sealing tests</i> ... ..	56
<i>Inspection</i> ... ..	27	<i>Insulation resistance tests</i> ... ..	58
<i>Fault-finding</i> ... ..	30		

#### LIST OF ILLUSTRATIONS

	<i>Fig.</i>		<i>Fig.</i>
<i>External view</i> ... ..	1	<i>Special tools</i> ... ..	5
<i>Exploded view</i> ... ..	2	<i>Transformer and transductor winding</i>	
<i>Block diagram</i> ... ..	3	<i>resistances</i> ... ..	6
<i>Circuit diagram</i> ... ..	4	<i>Component layout and wiring diagram</i>	7

#### LIST OF APPENDICES

	<i>App.</i>
<i>Standard serviceability tests for Type 23</i>	
<i>Controller</i> ... ..	1

**RESTRICTED**

## LEADING PARTICULARS

<i>Controller, Plessey Type 23, Part No. 506-1-00488</i>		... Ref, 5UC/7628
<i>Input power supply</i>	... ..	115V $\pm 5\%$ , 400c/s $\pm 5\%$
<i>Sensing elements resistance</i>	... ..	100 ohms at 20 deg. C.
<i>Control channel operating point (cut-out)</i>	... ..	40 $\pm 1$ deg. C.
<i>Differential between cut-out and cut-in (of control channel)</i>		... .. 1 deg. C. max.
<i>Overheat channel operating point (cut-out)</i>	... ..	55 $\pm 5$ deg. C.
<i>Differential between cut-out and cut-in (of overheat channel)</i>		... .. 15 deg. C.
<i>Terminals</i>	... ..	6 BA
<i>Power supply</i>	... ..	A3, X1
<i>Control channel sensing element</i>	... ..	A1, A2
<i>Overheat channel sensing element</i>	... ..	B1, B2
<i>Control channel to windscreen heater circuit</i>	... ..	C3, D2
<i>Overheat channel to windscreen heater circuit</i>	... ..	D1, C2
<i>(Optional for lamp indicator circuit)</i>		... .. D1, C1
<i>Relays</i>	... ..	Miniature, base-mounted, open types
<i>Contacts rating</i>	... ..	3A at 150V a.c. or 28V d.c. with non-inductive loads
<i>Control channel</i>	... ..	Double pole, changeover, only one contacts set used
<i>Overheat channel</i>	... ..	Single pole, changeover
<i>Operating ambient temperature</i>	... ..	-40 deg. C. to +85 deg. C.

### Introduction

1. Plessey Type 23 de-icing controller (fig. 1) maintains aircraft windscreen temperatures at pre-determined levels by controlling the electrical supply to the windscreen heaters.

2. The controller is a sealed unit comprising two channels, control and overheat; each channel is connected to a sensing element which has a positive resistance/temperature characteristic and is embedded in the windscreen. Normally, the control channel regulates the operation of the windscreen heater; the overheat channel is provided as a standby and takes over control automatically in the event of failure of the control channel, maintaining the windscreen temperature at a higher (the overheat) level than the nominal setting.

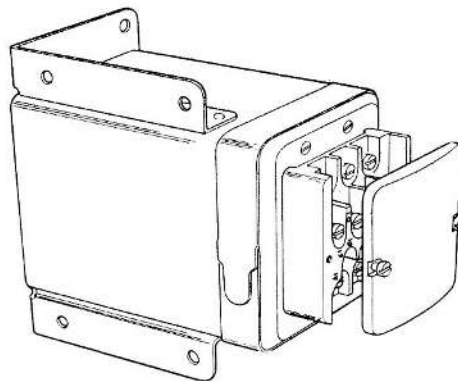

Fig. 1. External view

**RESTRICTED**

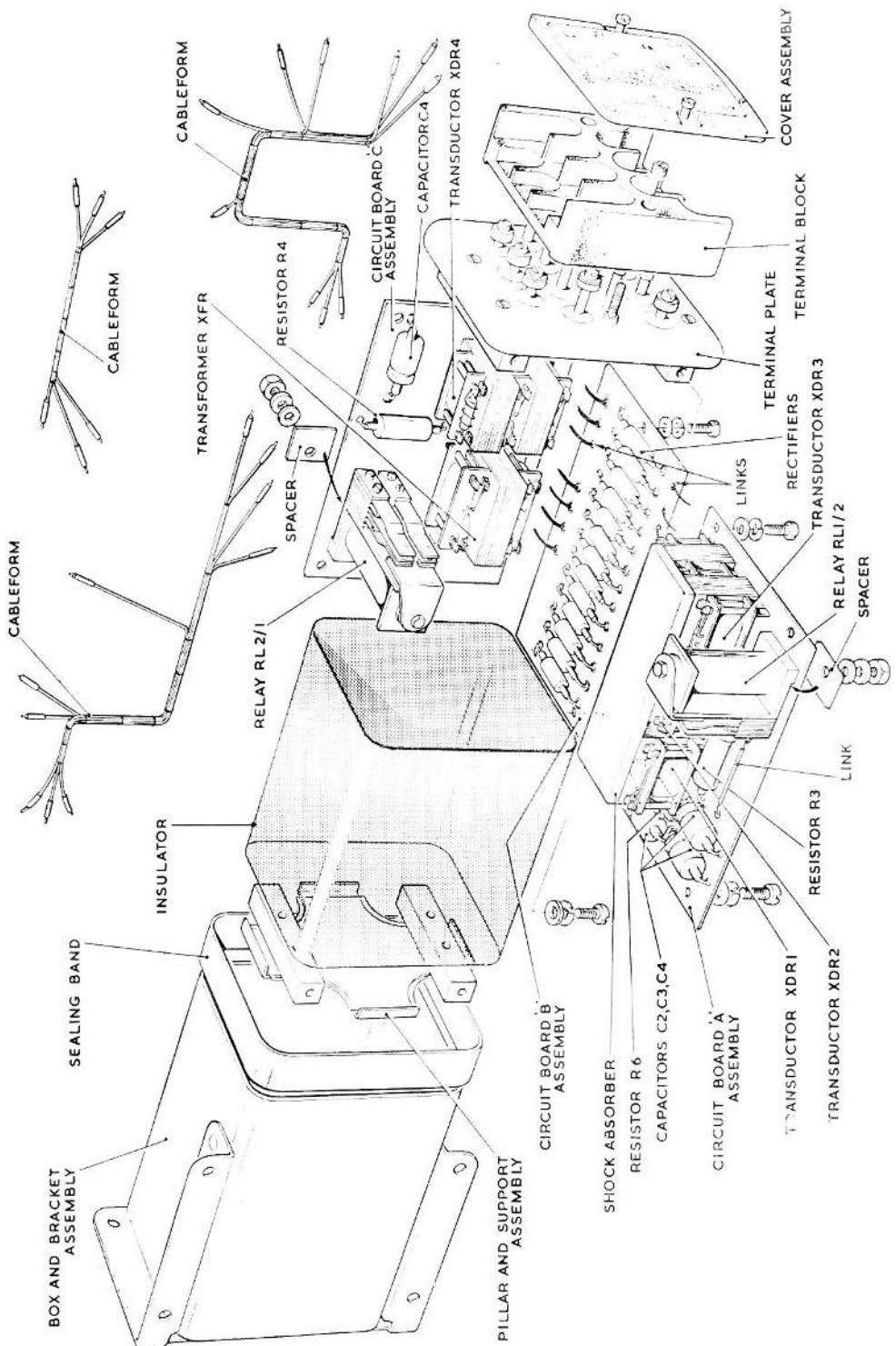

Fig. 2. Exploded view

RESTRICTED

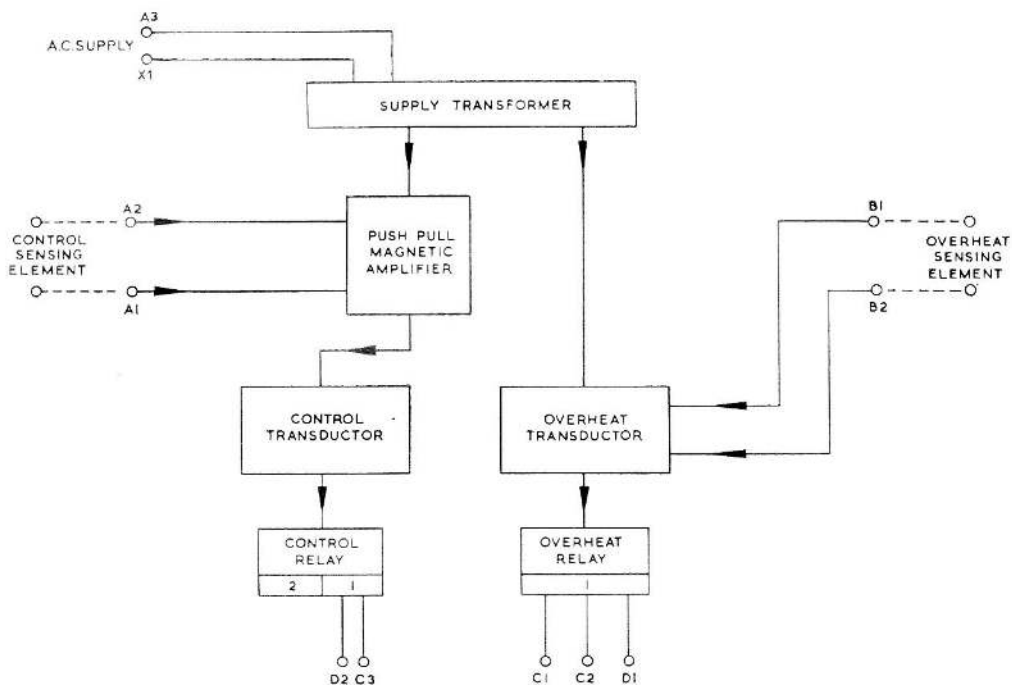

Fig. 3. Block diagram

### DESCRIPTION

3. An exploded view of the controller is shown in Fig. 2. It is constructed on the three printed circuit boards shown: the static components are soldered to the circuit foil; the relays are secured by nuts and washers. The circuit boards hinge about inter-connecting links which are part of the circuit; the components on adjacent boards are inter-connected by cableforms.

4. When assembled, the circuit boards are secured in 'U' formation to the pillar and support assembly and the terminal plate and encased with the glassboard insulator wrapped around them in the box and bracket assembly. The joint between the terminal plate and the box is then sealed by a soldered band.

5. The terminals are glass-sealed in the terminal plate and shrouded by the detachable terminal block and the cover.

### OPERATION

#### General

6. Basically each channel comprises: a sensing circuit, in which the sensing element and fixed resistances (transducer control windings and

other resistors) are connected in parallel; and an output stage consisting of a bistable transducer and a relay, XDR3 and RL1/2 for the control channel, and XDR4 and RL2/1 for the overheat channel, as shown in Fig. 3.

7. Current flow through the sensing circuit influences the bistable transducer, the output of which is applied to the relay (which controls the contactor in the supply lines to the wind-screen heater). As the sensing element resistance changes with temperature, current flow through the sensing circuit and hence the outputs of the channels are dependent on wind-screen temperature.

8. In the overheat channel the output transducer is controlled directly by the sensing circuit; in the control channel an intermediate stage, transducers XDR1 and XDR2 connected in push-pull, is interposed between the sensing circuit and the output stage to amplify the effective signal and thus make the control channel more sensitive.

9. The control points of the channels differ, that of the overheat channel being higher than the control, but each is determined by the ratio of the sensing element resistance to that of the reference resistor (R3 or R4, Fig. 4).

RESTRICTED

### Control channel

10. The circuit diagram is illustrated in Fig. 4. The sensing element S1 and resistor R3 are connected in parallel circuits (fed by SEC1 of XFR through D11 and D12) each of which incorporates a control winding of transductor XDR1 and XDR2. The control windings in each circuit are connected in series and in opposition so that XDR1 and XDR2 act in push-pull amplification. The outputs of these transductors are magnetically mixed in the control windings of bistable transductor XDR4, the output of which is applied to relay RL1/2. Thus, as the resistances of the control windings and R3 are fixed, the resistance of S1 which varies with temperature (or faults) determines the current flow in the parallel sensing circuits and, hence, the operative condition of the relay.

11. At temperatures below the control point (cold windscreen condition) the resistance of S1 is less than R3. The current flow through the S1 circuit is greater than that through the R3 circuit and the output of the push-pull amplifier (that of XDR1 is greater than XDR2) drives XDR3 into maximum output. Relay RL1/2 is energized and its contacts, RL1-1 and RL1-2, close making the external circuit through terminals D2 and C3, thereby connecting power to the windscreen heater.

12. With heat applied to the windscreen the resistance of sensing element S1 increases, inversely varying the current flow through the parallel circuits so that the output of XDR1 starts to fall and that of XDR2 rises. At the control temperature the resistance of S1 is nearly equal to that of R3, the parallel circuits are balanced and the output of the push-pull amplifier drives XDR3 towards minimum output. Relay RL1/2 is de-energized and its contacts open breaking the external circuit through terminals D2 and C3, thereby disconnecting power from the windscreen heater.

13. With heating power disconnected the windscreen temperature falls reducing the resistance of S1 until the 'cold' windscreen condition is restored, i.e. the current flow through the S1 circuit is greater than the R3 circuit. The heating operation is then initiated and the cycle repeats.

14. In the event of the sensing element becoming short-circuit the normal sequence of operations as for a 'cold' windscreen occurs (as the resistance of S1 will be lower than that of R3), relay RL1/2 is energized and power

supply is connected to the windscreen heater causing the windscreen temperature to rise until the overheat channel takes over control. In open-circuit condition, transductor XDR3 is driven towards minimum output as for a 'hot' windscreen (since the resistance of R3 circuit will be lower than the S1 circuit), relay RL1/2 is de-energized and power supply to windscreen is disconnected. Hence, a 'fail safe' facility is incorporated to prevent damage to the windscreen in either fault condition.

### Overheat channel

15. The sensing element S2 and resistor R4 are connected in parallel circuits each in series with a control winding of transductor XDR4 the output of which is applied to relay RL2/1.

16. As in the control channel, the resistance of S2 in relation to R4 determines the current flow through the parallel circuits. At temperatures below the overheat channel control point (which is higher than that of the control channel), the resistance of S2 is lower than R4 and transductor XDR4 is driven into low output. Relay RL2/1 is de-energized and the contacts brought out to terminals C2 and D1, which are also connected into heater power supply circuit, remain closed.

17. If, due to malfunctioning of the control channel, the windscreen temperature rises until the resistance of S2 is nearly equal to R4, transductor XDR4 is driven into maximum output and relay RL2/1 is energized. The relay contacts open breaking the circuit through terminals C2 and D1 thereby interrupting power supplies to the windscreen heater.

18. In the event of the sensing element becoming open-circuit, the functioning of the output stage is identical to that described for the 'hot' windscreen condition in the control channel; hence, relay RL2/1 is energized and the power supplies to the windscreen heater are interrupted if this fault occurs.

## INSTALLATION

19. The controller may be mounted in any attitude; refer to the leading particulars for installation details. In order to obtain access to the terminals, the cover, which is secured by two captive slotted-head nuts, must be detached.

**RESTRICTED**



**SERVICING**

20. No in situ maintenance is required.

21. If the operation of the controller is suspect, the standard serviceability tests detailed in Appendix A should be applied.

22. If the results of the tests are unsatisfactory, dismantle and effect corrective action in accordance with the sequence detailed in the following paragraphs.

**Tools and test equipment**

23. Except for the fork screwdriver illustrated in Fig. 5, standard tools normally available in a workshop will suffice to dismantle and re-assemble a controller. The following test equipment is required for testing and fault finding:—

- (1) Insulation resistance tester, 500V, Type A (Ref. No. 5G/1621).
- (2) Two decade resistance boxes or similar equipment calibrated from 50–150 ohms and adjustable in steps of 0.1 ohm. (Ref. No. 5G/3217).

(3) Sealing test adapter (Plessey No. T.361439, Fig. 5).

(4) Testmeter, Type 1 (Ref. No. 5QP/16411).

(5) Three 3-watt lamp circuits (or similar continuity test equipment).

**Dismantling**

24. The following is the dismantling procedure:—

- (1) Release the captive nuts and remove the cover assembly.
- (2) Detach the terminal block by removing the two round nuts with a forked screwdriver (Fig. 5).
- (3) Grip the tab end of the sealing band with a suitable tool and pull away from the box.
- (4) Withdraw the controller assembly from the box and bracket assembly and remove the insulator.

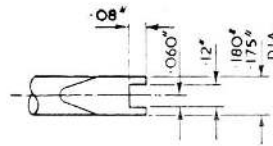

FORK SCREWDRIVER

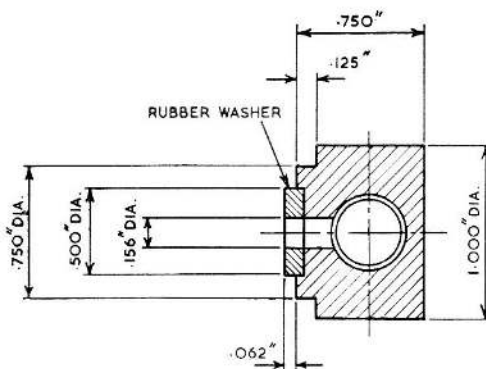

SEALING TEST ADAPTOR

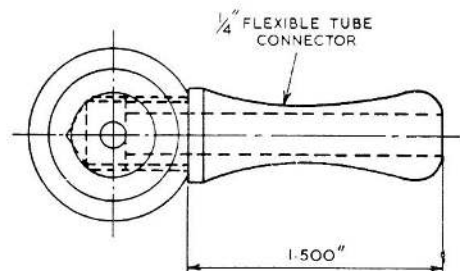

Fig. 5. Special tools

**RESTRICTED**

(5) Remove the screws and washers securing the circuit boards to the pillar and support assembly and withdraw the pillar and support assembly.

(6) Remove the screws and washers securing the two larger boards to the terminal plate assembly and lay out the boards flat.

**Note . . .**

*It is not necessary to unsolder the cable-forms or the flexible links between the circuit boards.*

(7) Clear the pin-hole in the side of the box of solder.

**Cleaning**

25. Blow out dust; clean generally, if necessary, with ESSO 10 solvent (B.S. 245).

26. Clean relay contacts as described in A.P. 4343, Vol. 1, Sect. 11, Chap. 2.

**Caution . . .**

*Do not use trichlorethylene as a cleaning agent as it can cause contamination of electrical contacts.*

**Inspection**

27. Examine the controller for obvious defects, e.g. broken terminals, frayed or disconnected cables, etc.

28. Examine the printed circuit boards and the mounted components for evidence of overheating.

29. Check the security of attachment of all components.

**Fault finding**

30. Three types of faults, as determined by assessment of the results of the standard serviceability tests, are possible:—

- (1) Those causing malfunctioning of both channels.
- (2) Those affecting the control channel only.
- (3) Those affecting the overheat channel only.

31. The fault finding procedures detailed in the following paragraphs are divided into the

three main categories. The transformer and transducer check points referred to are those shown in Fig. 6, the circuit references are those used in Fig. 4.

*Faults affecting both channels*

32. Power supply transformer: Transformer failure will affect both channels. Check that 6V a.c. output is obtained between the secondary windings centre-taps and the respective ends of the windings. The check points are as follows:—

- (1) SEC. (secondary 1 CT (centre-tap) to the positive (red) lead of rectifiers D11 and D12.
- (2) SEC. 2 CT to the positive (red) lead of rectifiers D13 and D14.
- (3) SEC. 1 CT to the negative (black) lead of rectifiers D1, D2, D3, D4, D6 and D7.
- (4) SEC. 2 CT to the negative (black) lead of rectifiers D9 and D10.

*Faults affecting the control channel*

33. Power supply components: Power supply components are the rectifiers providing the feeds to the sensing element circuit and to the transducers of the push-pull amplifier and output stage.

- (1) Sensing element circuit rectifiers: Rectifiers D11 and D12 provide the power supplies to the sensing element circuit. A voltage of 4.25V d.c. approximately must be obtained between terminal A2 and transformer pin SEC. 1 CT (Fig. 6): if one of the rectifiers is open-circuit the output will drop to 2.2V d.c. when the relevant circuit is checked.
- (2) Rectifiers in the amplification and output stages: The relevant rectifiers are D1 and D2 for transducer XDR1, D3 and D4 for transducer XDR2, D6 and D7 for transducer XDR3. With a resistance box (simulating S1) connected across terminals A1 and A2 and set to the value of resistor R3, the voltage obtained between the positive (red) lead of each rectifier and transformer pin SEC. 1 CT must be approximately 1.25V d.c. The values obtained for each circuit pair of rectifiers should also be equal.

**34. Sensing element circuit:** Generally, faults will unbalance the currents flowing through S1 and R3 when the resistance of S1 (simulated by a decade resistance box across terminals A1 and A2) is equal to R3. This unbalance will appear as a p.d. of more than 10mV d.c. between A1 and the end of R3 that is connected to transducer XDR2. If this value is exceeded the faulty component may be located by the following checks which are performed with the controller disconnected from the input power supply.

(1) Disconnect the end of R3 from the foil that connects it to XDR2.

(2) Measure the resistance between the transformer pin SEC. 1 CT and terminal A1 and again between the same transformer pin and the end of the printed circuit from which R3 was disconnected. The readings obtained should be between 100 and 120 ohms and are the combined resistances of the control windings C1, C2 of transducers XDR1 and XDR2. If these readings are not obtained, the faulty transducer can be located by checking the winding resistances separately. Fig. 6 details the check points and the resistance values that must be obtained with the component removed from the circuit board.

(3) Check the value of resistor R3. Reconnect or renew, as necessary.

**35. Amplification stage:** These checks are performed with R3 reconnected to the circuit and a decade resistance box, simulating S1, connected across terminals A1, A2.

(1) With nominal power supply connected to the controller and S1 set to the value of R3, measure the voltages across capacitors C1 and C2. The readings should be equal and between 0.8V and 1.8V d.c. A reading above the upper limit indicates an open-circuit control winding C1 or C2 on transducer XDR3 (refer to Fig. 6).

(2) Increase the resistance of S1 by 10 ohms: the voltage should increase across capacitor C2 and decrease across C1. If this does not occur a fault is indicated in rectifier D5 which can be checked with a low-voltage ohmmeter.

**36. Output stage:** These checks should follow the preceding stage checks.

(1) With S1 adjusted so that the voltages across capacitors C1 and C2 are equal, measure the voltage across capacitor C3; a reading of 5V d.c. approximately, must be obtained. A reading of 4V d.c. approximately, indicates an open-circuit in capacitor C3; a reading of 7V d.c. an open-circuit coil in relay RL1/2; a reading of 1V d.c. approximately, an open-circuit in one of the windings, AC1 or AC2, of transducer XDR3. The transducer windings can be checked in accordance with Fig. 6.

#### *Faults affecting the overheat channel*

**37. Power supply components:** Power supply components are the rectifiers providing the feeds to the sensing element circuit and the transducer in the output stage.

(1) Sensing element circuit rectifiers: Rectifiers D13 and D14 provide supplies to the sensing element circuit. A voltage of 4.25V d.c. approximately, must be obtained between terminal B1 and transformer pin SEC. 2 CT: if one of the rectifiers is open-circuit the output voltage will drop to 2.2V d.c.

(2) Output stage rectifiers: With a resistance box (simulating S2) connected across terminals B1 and B2 and set to the value of R4, the voltages between transformer pin SEC. 2 CT and the positive (red) leads of rectifiers D9 and D10 must be equal and approximately 1.25V d.c.

**38. Sensing element circuit:** Generally, faults will unbalance the currents flowing through S2 and R4 when the resistance of S2 is equal to R4. This unbalance will appear as a p.d. of more than 10mV d.c. between terminal B2 and the end of R4 that is connected to transducer XDR4. If this value is exceeded the faulty component may be located by the following checks which are performed with the controller disconnected from the input power supply.

(1) Disconnect the end of R4 from the foil that connects it XDR4.

(2) Measure the resistance between the transformer pin SEC. 2 CT and terminal B2 and again between the same transformer pin and the end of the printed circuit from which R4 is disconnected. These readings should be between 50 and 60 ohms which is the resistance value of each of the

control windings, C2 and C1, on transducer XDR4. If a faulty control winding is indicated, the conclusion can be confirmed by checking the resistance with the transducer XDR4 removed from the circuit board.

(3) Check the value of resistor R4. Renew or reconnect as necessary.

**39. Output stage:** These checks are performed with R4 reconnected to the circuit and a decade resistance box, to simulate S2, connected across terminals B1, B2.

(1) With nominal power supply connected to the controller, adjust S2 so that the voltage between transformer pin SEC. 2 CT and terminal B2 is equal to that between the same transformer pin and the end of R4 that is connected to transducer XDR4. Measure the voltage across capacitor C4. The reading obtained should be 5V d.c. approximately. A reading of 4V d.c. indicates an open-circuit in capacitor C4; 8V d.c. an open-circuit in one of the windings, AC1 or AC2, of transducer XDR4. The transducer windings can be checked in accordance with Fig. 6.

### Repair

**40.** Repair is effected by renewal of faulty components. Refer to Fig. 7 for the component

layout and wiring diagram and to Fig. 2, the exploded view. Note especially the position of the sharper corners of the transducers in the plan view (Fig. 7).

**41.** Except for the two relays, all components are soldered to the circuit foil and renewal is straightforward. When transducer XDR1, XDR2 or XDR3 is to be removed the shock absorber will have to be pulled away and it should be renewed on reassembly. The shock absorber is affixed with silicone rubber adhesive.

**42.** Each relay is mounted over a spacer and is secured to the board by a brass nut with a nylon washer adjacent to the board and a brass washer between the nut and the nylon washer (refer Fig. 2).

**43.** When cables are being detached, identify them as unsoldering proceeds.

**44.** Use a soldering iron of small heat capacity (approx. 30 watts) and a heat-shunt where practicable.

**45.** Use only 036-20 S.W.G. multicore solder (Ref. No. 30B/1606) and after soldering brush off flux deposits with 4 : 1 mixture of iso-propyl alcohol and xylene.

**46.** After renewal of a component, coat the board area affected by the repair, with DEF 32/2 clear, anti-tracking varnish. When capa-

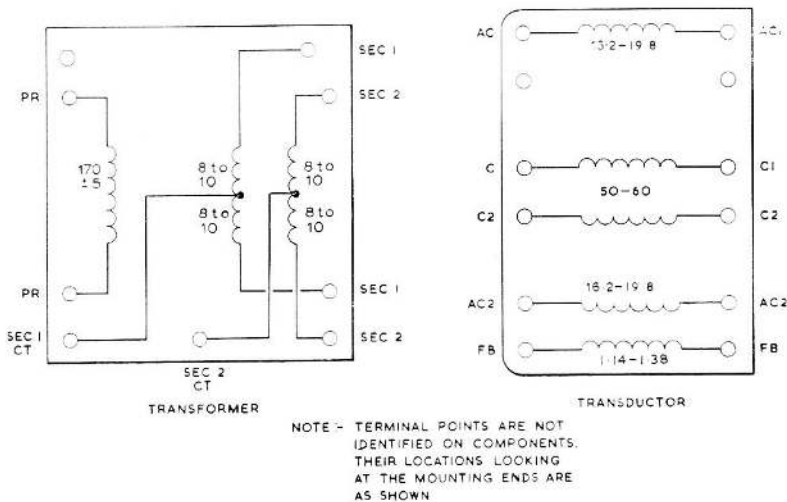

**Fig. 6. Transformer and transducer winding resistances**

**RESTRICTED**

citators are renewed, bind the capacitors to the circuit board, as originally, with linen thread and coat the bindings with air-drying, fungicidal varnish.

### Assembling

47. The following is the assembling procedure:—

- (1) Fold in the larger circuit boards one at a time and secure to the terminal plate with screws and washers.
- (2) Install the pillar and support assembly and secure the circuit boards to the pillars with screws and washers.
- (3) Fold the glass-board insulator around the circuit boards, trapping the edges under the flanges of the terminal plate and pillar and support assemblies.
- (4) Slide the controller assembly into the box and bracket assembly.
- (5) Test the controller as detailed in para. 48 to 55.
- (6) Solder a new sealing band around the joint of the box and bracket assembly and the terminal plate assembly, leaving about  $\frac{3}{8}$  in. unsoldered as a removal tab: a 75 watt soldering iron may be used for this operation.
- (7) Test the controller for leaks as detailed in para. 56.
- (8) Dry out and seal the pin-hole in the side of the container with solder.
- (9) Perform the sealing test detailed in para. 57.
- (10) Secure the terminal block to the terminal plate assembly with round nuts, using a fork screwdriver (Fig. 5).
- (11) Repeat the function tests as detailed in para. 51 and 52 and then check insulation resistance as detailed in para. 58.
- (12) Fit and secure the cover assembly.

### Testing

#### Preparation

48. Connect two decade resistances boxes, S1 and S2, calibrated from 50 to 200 ohms to terminals A1 and A2 (S1) and B1 and B2 (S2).

These decade boxes (S1 and S2) simulate the control and overheat sensing elements respectively.

49. Connect three continuity testers (L1, L2, L3) across terminals C3, D2 (L1); C2, D1 (L2); and C1, D1 (L3). It is assumed in the following paragraphs that lamps are used and as the contacts of the relays are brought out to these terminals (refer Fig. 4), illumination of the lamps will indicate the following conditions:—

- L1: control relay RL1/2 is energized
- L2: overheat relay RL2/1 is de-energized
- L3: overheat relay RL2/1 is energized.

When L1 and L2 light simultaneously, the windscreen heater 'ON' condition is simulated; any other combination indicates that the windscreen heater is 'OFF'.

#### Control channel operating point

50. If transducer XDR1 and/or XDR2 has been renewed or if the channel requires balancing as determined by subsequent tests, adjust the operating point of the push-pull amplifier as follows:—

- (1) If not installed, wind five strands of 43 S.W.G. bare Eureka wire between the bias winding pins, FB, Fig. 6, on transducers XDR1 and XDR2.
- (2) Connect nominal power supply of 115V, 400 c/s to the controller input terminals X1 and A3.
- (4) Set both resistance boxes (S1 and S2) to 110.6 ohms: lamps L1 and either L2 or L3 should light.
- (5) Measure the voltage across capacitors C1 and C2 and remove strands of Eureka wire, one at a time, from the appropriate transducer until the voltage values are equal and between 0.8 and 1.8V d.c.

#### Note . . .

*These Eureka wire shunts are the resistances R1 and R2 (Fig. 4).*

#### Function tests

51. *Control channel:* With input power supplies of 120.75V, 380 c/s 115V, 400 c/s and 109.25V, 420 c/s, in turn, connected to the input terminals X1 and A3, check the functioning of the control channel as follows:—

- (1) Set both decade resistances to 105 ohms. Lamp L1 should light, indicating

that relay RL1/2 (control) is energized and L2 should light indicating that relay RL2/1 (overheat) is de-energized.

(2) Slowly increase the control resistance (S1) value and note the reading at which L1 is extinguished. This should occur between 110.2 and 111.2 ohms.

(3) Gradually reduce the value of the control resistance until L1 lights again. This should occur at not more than 0.5 ohms less than the reading obtained at the preceding step (2).

(4) If these requirements are not met, re-adjust the bias winding shunt resistances as detailed in para. 50.

**52. Overheat channel:** With input supplies of 120.75V, 380 c/s, 115V, 400 c/s and 109.25V, 420 c/s, in turn, connected to the controller, perform the following steps:—

(1) Set both decade resistances to 105 ohms: lamps L1 and L2 should light.

(2) Increase the value of the overheat resistance (S2) until L2 is extinguished (and L3 lights): this should occur between 116.1 to 121.4 ohms.

(3) Reduce the overheat resistance and note the reading at which L2 lights again (L3 will be extinguished). This should occur at a value between 5 and 8 ohms lower than the reading obtained at the preceding step, (2), i.e. the difference between L2 and L3 'ON'.

**53.** To obtain the stipulated differentials it may be necessary to vary the value of the feedback winding resistance of XDR4 by shunting it. The procedure is as follows:—

(1) If not installed, wind a length, approximately 6 in., of 43 S.W.G. bare Eureka wire on the body of a 20-ohms resistor and tack the ends and the resistor across the feedback winding pins, FB, Fig. 6.

(2) Repeat the function test in para. 52 and vary the length of Eureka wire, as necessary, to give the required trimming.

(3) On successful completion of this adjustment, ensure that the Eureka wire and resistor are securely soldered in position.

#### *Relay contacts tests*

**54.** These are tests to determine the serviceability of relay contacts; they can be effected on sealed controllers.

**55.** With the controller connected to decade resistance boxes as in para. 48 and the continuity test lamps (para. 49) disconnected, perform the following steps:—

(1) Set the control (S1) and overheat (S2) resistances to approximately 105 ohms: this is to ensure that relay RL1/2 is energized and relay RL2/1 is de-energized.

(2) Apply 1A d.c. through the closed contacts RL1-1 and RL1-2 (Fig. 4) of relay RL1/2 and RL2-1 and RL2-2 of relay RL2/1 through the terminal pairs C3, D2 and D1, C2, respectively, and measure the millivolt drop across the contacts (terminals). The readings obtained should not exceed 100mV.

(3) Increase the overheat resistance to about 130 ohms: this is to ensure that relay RL2/1 is energized.

(4) Apply 1A d.c. through the closed contacts RL2-2 and RL2-3 of relay RL2/1 via terminals D1 and C1 and measure the millivolt drop across the contacts (terminals). The reading obtained should not exceed 100mV.

(5) Disconnect test equipment.

#### *Sealing tests*

**56. Pin-hole open:** A clean, dry, compressed air supply which can be regulated to 15 lb/in<sup>2</sup> and a suitable adapter (Fig. 5) to connect the air supply to the controller through the pin-hole in the cover and bracket assembly are required.

(1) Clamp the adapter over the pin-hole, submerge the controller in water and apply an air pressure of 15 lb/in<sup>2</sup>. There must be no evidence of air-leakage from the controller.

(2) Keep the controller pressurized, remove it from the water container and shake off as much water as possible.

(3) Turn off the air supply and remove the sealing test adapter.

(4) Dry out the controller for about an hour at a temperature of about 80 deg. C.

**RESTRICTED**

**57. Pin-hole closed:** A beaker, a bell-jar and any convenient air extractor (or depressurizing system) are required.

- (1) Submerge the controller in cold distilled water contained in a suitably-sized beaker. Stir in a little wetting agent (a liquid soap) into the water.
- (2) Cover the beaker with a bell-jar: the bell-jar must stand on the same supporting surface as the beaker.
- (3) Depressurize the atmosphere within the bell-jar to 2.2 in. Hg. There must be no evidence of air leakage from the controller.
- (4) Remove the controller and dry out.

*Insulation resistance tests*

**58.** With the controller connected to resistance boxes as detailed in para. 48, and nominal power supply connected to the input terminals, apply

the following tests:—

- (1) Set the control and overheat resistances to about 100 ohms (to ensure that relay RL1/2 is energized and RL2/1 is de-energized) and measure the insulation resistance at 500V d.c. between terminals C1 and D1, C1 and C3, C2 and C3. The values obtained must be not less than 5 megohms.
- (2) Increase the control resistance to about 120 ohms and the overheat resistance to about 130 ohms (to ensure that relay RL1/2 is de-energized and relay RL2/1 is energized) and measure the insulation resistance at 500V d.c. between terminals D1 and C2, D2 and C3. The values obtained must be not less than 5 megohms.
- (3) With all test equipment disconnected, measure the insulation resistance at 500V d.c. between all terminals connected together and the box and bracket assembly. The value obtained must be not less than 5 megohms.

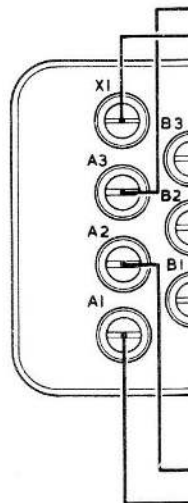
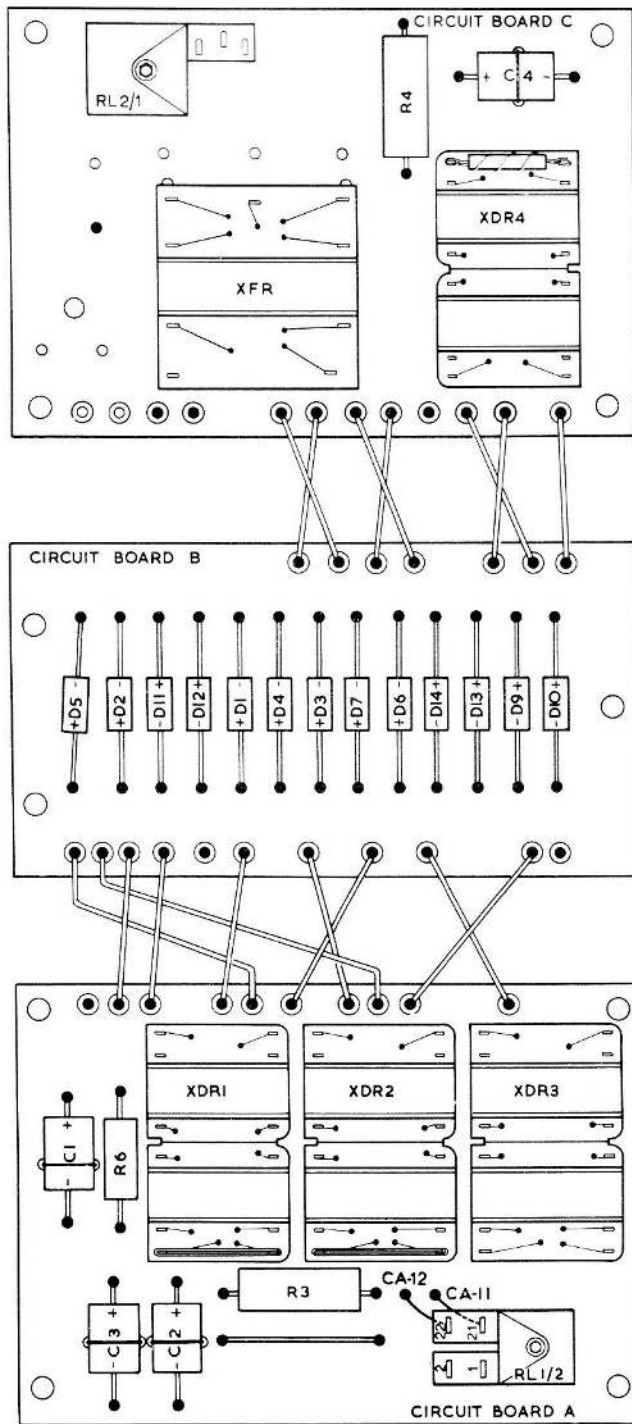

200V a.c. YELLOW			CABLEFO CONTROL BLA	
FROM	TO	LENGTH IN.	FROM	TO
TB-A3	CC-3	4 3/16	TB-A1	RLI-
TB-XI	CC-13	4 3/8	TB-A2	CB-
			TB-C3	RLI-
			TB-D2	RLI-
			CA-10	CC-

ABBREVIATIONS:  
T.B.-TERMINAL BLOCK; CA.CB.CC.-

- NOTES
1. INTER-CONNECTIONS OF CIRCUIT BOARD BY SEPARATE LINKS; THOSE ON THE
  2. THE TERMINAL BLOCK IDENTIFICATION THE TERMINAL BLOCK; ALL OTHER I

Fig.7

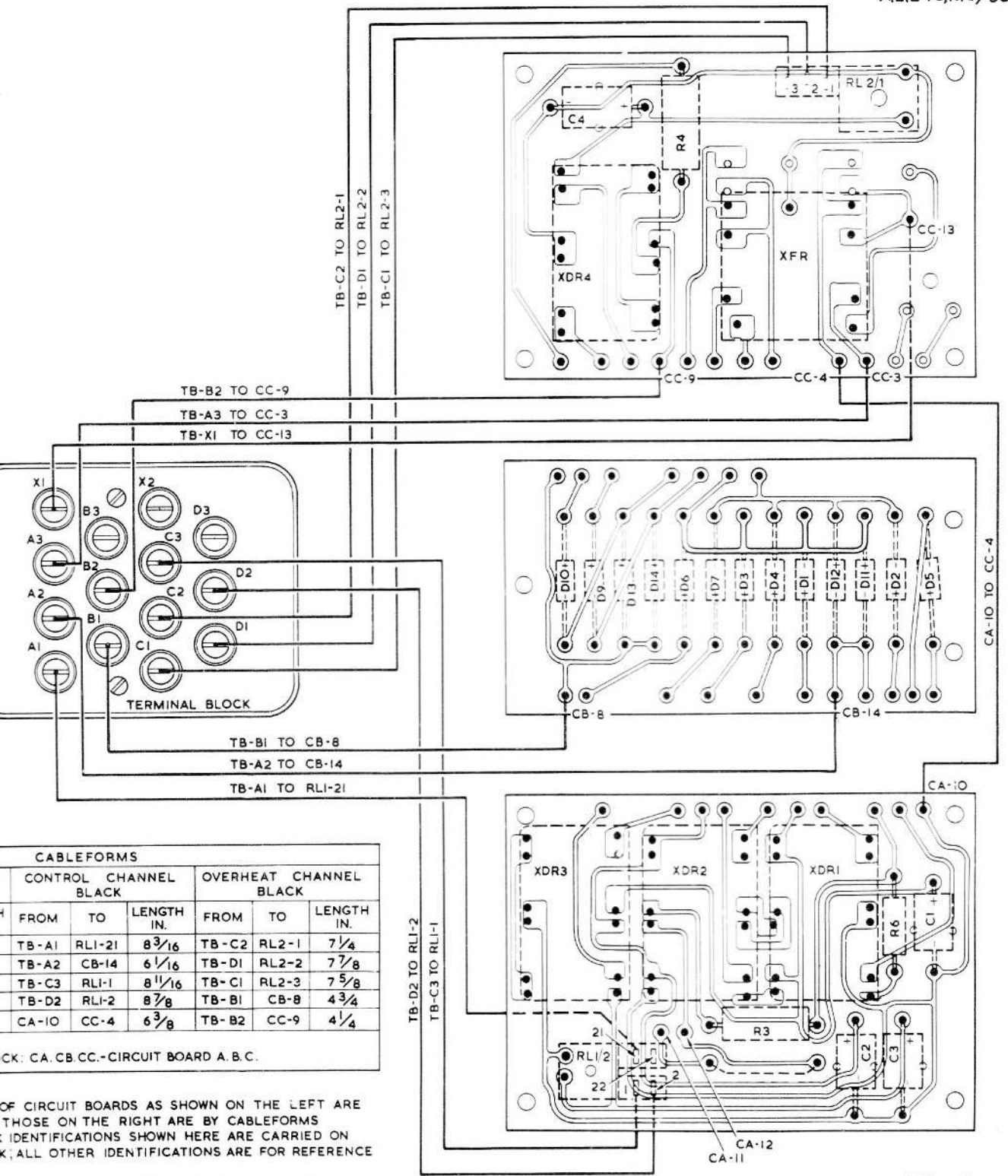

TB-B2 TO CC-9  
TB-A3 TO CC-3  
TB-X1 TO CC-13

TB-B1 TO CB-8  
TB-A2 TO CB-14  
TB-A1 TO RLI-21

TB-D2 TO RLI-2  
TB-C3 TO RLI-1

CA-10 TO CC-4

CA-10

CA-12  
CA-11

CABLEFORMS					
CONTROL CHANNEL BLACK			OVERHEAT CHANNEL BLACK		
FROM	TO	LENGTH IN.	FROM	TO	LENGTH IN.
TB-A1	RLI-21	8 <sup>3</sup> / <sub>16</sub>	TB-C2	RL2-1	7 <sup>1</sup> / <sub>4</sub>
TB-A2	CB-14	6 <sup>1</sup> / <sub>16</sub>	TB-D1	RL2-2	7 <sup>7</sup> / <sub>8</sub>
TB-C3	RLI-1	8 <sup>11</sup> / <sub>16</sub>	TB-C1	RL2-3	7 <sup>5</sup> / <sub>8</sub>
TB-D2	RLI-2	8 <sup>7</sup> / <sub>8</sub>	TB-B1	CB-8	4 <sup>3</sup> / <sub>4</sub>
CA-10	CC-4	6 <sup>3</sup> / <sub>8</sub>	TB-B2	CC-9	4 <sup>1</sup> / <sub>4</sub>

KEY: CA, CB, CC - CIRCUIT BOARD A, B, C.

OF CIRCUIT BOARDS AS SHOWN ON THE LEFT ARE  
THOSE ON THE RIGHT ARE BY CABLEFORMS  
IDENTIFICATIONS SHOWN HERE ARE CARRIED ON  
KEY; ALL OTHER IDENTIFICATIONS ARE FOR REFERENCE

Layout and wiring diagram  
RESTRICTED

Fig. 7

## Appendix A

### STANDARD SERVICEABILITY TESTS

#### WINDSCREEN DE-ICING CONTROLLERS, PLESSEY, TYPE 23

##### Introduction

1. These tests may be applied prior to installation or when serviceability of the unit is in doubt.

##### TEST EQUIPMENT

2. The following equipment is required.

- (1) Insulation resistance tester, 500V, Type A (Ref. No. 5G/1621).
- (2) 115V, 400 c/s single-phase supply.
- (3) Two decade resistance boxes calibrated from 50 to 200 ohms and adjustable in steps of 0.1 ohm (Ref. No. 5G/3217 or equivalent).
- (4) Three 3-watt lamps or similar equipment for testing continuity.

##### TEST PROCEDURE

###### Preparation

3. Simulate the control (S1) and overheat (S2) sensing elements by connecting one resistance box between terminals A1 and A2 (S1) and the other between terminals B1 and B2 (S2).

4. Connect the three lamps (L1, L2, L3) to the terminals C3, D2 (L1); C2, D1 (L2) and C1, D1 (L3). The lamps are to indicate closing of the contacts of the two relays and when illuminated indicate the following conditions:—

- L1: Control relay RL1/2 energized
- L2: Overheat relay RL2/1 de-energized
- L3: Overheat relay RL2/1 energized.

When L1 and L2 light simultaneously, the windscreen heater 'ON' condition is simulated; any other combination indicates that the windscreen heater is 'OFF'.

###### Control channel functioning

5. Connect the power supply to terminals X1 and A3. Set both decade resistance boxes to 105 ohms: lamps L1 and L2 should light.

6. Slowly increase the value of the control resistance (S1) until L1 is extinguished. This should occur at a resistance value between 110.2 and 111.2 ohms.

7. Gradually reduce the value of the control resistance until L1 lights again. This should occur at not more than 0.5 ohms less than the preceding reading (para. 6).

###### Overheat channel functioning

8. With test equipment and supply connected as for the previous test, set the resistance of both decade resistance boxes to 105 ohms: lamps L1 and L2 should light.

9. Increase the value of the overheat resistance until L2 is extinguished (and L3 lights). This should occur at a resistance value between 116.1 and 121.4 ohms.

10. Reduce the value of the overheat resistance until L2 lights again (and L3 is extinguished). This should occur at a value between 5 and 8 ohms less than the preceding reading (para. 9), i.e. the difference between L2 and L3 'ON'.

###### Insulation resistance

11. With 115V, 400 c/s power supply applied to terminals A3 and X1, and decade resistance boxes connected to the terminals detailed in para. 3, set the control and overheat resistance to 105 ohms each (to ensure that RL1/2 is energized and RL2/1 is de-energized). Check the insulation resistance at 500V d.c. between terminals C1 and D1, C1 and C3, C2 and C3. The minimum permissible value is 5 megohms.

12. Increase the control resistance to 120 ohms and the overheat resistance to 130 ohms (relay RL1/2 de-energized, RL2/1 energized). Check the insulation resistance at 500V d.c. between terminals D1 and C2, D2 and C3. The minimum permissible value is 5 megohms.

13. Units which fail any test may be rectified within the scope of spares availability as detailed in the main chapter.

**RESTRICTED**

This file was downloaded  
from the RTFM Library.

Link: [www.scottbouch.com/rtfm](http://www.scottbouch.com/rtfm)

Please see site for usage terms,  
and more aircraft documents.



**TELEBRIEF  
CONNECTIONS**

**E**