

Chapter 1

ANTI-SKID CONTROL BOX ◀E.31082 ▶

LIST OF CONTENTS

	Para.		Para.
<i>Introduction</i>	1	<i>Testing (using Functional Tester)</i> ..	9
Description	2	<i>Sensitivity test</i>	10
Operation	4	<i>Functional test</i>	11
<i>Skid detection</i>	5	<i>Testing (without Functional Tester)</i> ..	12
<i>Amplifier</i>	6	<i>Sensitivity test</i>	13
<i>Memory circuit</i>	7	<i>Functional test</i>	14
Servicing	8	◀ <i>Storage</i> ▶	15 ▶

LIST OF ILLUSTRATIONS

	Fig.
<i>Control box</i> ◀E.31082 ▶	1
<i>Control box interior</i>	2
<i>Basic skid detection circuit</i>	3
<i>Circuit diagram</i>	4

LEADING PARTICULARS

Control Box E◀31082▶	Ref. No. 27G/2960
<i>Input supply</i>	24-28V d.c.
<i>Dimensions</i>	7 $\frac{1}{4}$ in. × 2 in.
<i>Weight</i>	1 lb 6 oz
<i>Fixing centres</i>	2 $\frac{5}{8}$ in. × 4 in.
<i>Electrical connection</i>	Cannon plug MS.3102A-18-1P

Introduction

1. The control box ◀E.31082 ▶ (fig. 1) forms part of the Goodyear Anti-Skid system, the function of which is to prevent the skidding of aircraft wheels during a landing. The control box is used in conjunction with two generators mounted in brackets attached to the aircraft undercarriage and driven by the aircraft wheels, and two solenoid valves located in the hydraulic supply lines to the aircraft brakes. For information on the generators and flywheel assembly,

refer to Chap. 2 of this Section, details of the solenoid valves may be found in A.P.1803A, Vol. 1, Sect. 9. The control box contains the control circuits for both port and starboard brakes. The outputs from the two wheel-driven generators are fed into the control box and thence to the port and starboard channels. Each channel comprises a skid detection circuit and an amplifier. The amplifier operates a relay, the contacts of which switch a 28V d.c. supply to the appropriate solenoid operated valve.

RESTRICTED

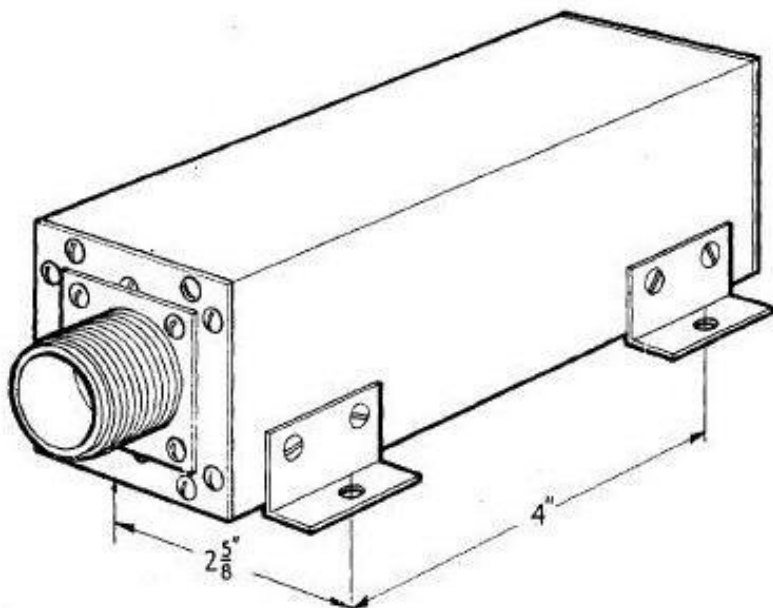

Fig. 1. Control box E.31082

DESCRIPTION

2. The control box E.31082 comprises two basic parts (fig. 2), the chassis and the outer case. The chassis accommodates the capacitors, resistors, relays, potentiometers and transistors. The outer case is fabricated from light alloy extruded square tube and the complete assembly is attached to the aircraft structure by means of four right-angled mounting brackets.

3. The chassis consists of two alloy support rods, to which are attached the port and starboard tag-board sub-assemblies, each support rod being attached to the front cover by

a countersunk screw. The front cover incorporates the Cannon plug which connects the control box to the aircraft supply, the port and starboard solenoid valves, and the wheel-driven generators. The transistors and potentiometers are mounted on a panel at the rear end, and the relays are mounted on metal brackets attached to each tag-board sub-assembly.

OPERATION

4. As both port and starboard tag-board sub-assemblies are identical, the following description of the operation will consider the starboard channel only. When the aircraft

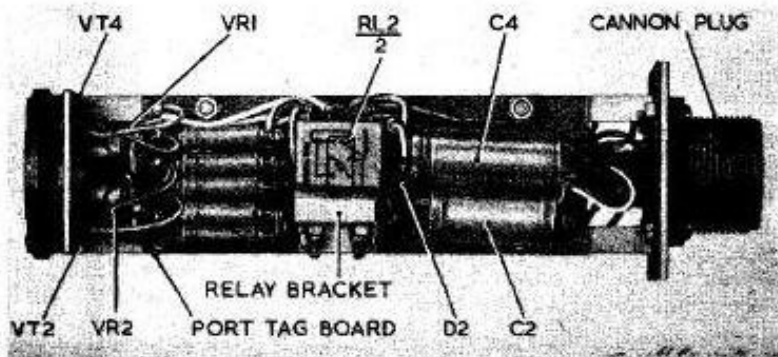

Fig. 2. Control box interior

RESTRICTED

touches down the wheels will accelerate until they reach the aircraft ground speed. During this acceleration period the generator voltage will increase and charge up the capacitor C3 via the diode D1 (fig. 3 and 4). When the acceleration ceases the generator voltage reaches a constant value and no further current will flow in the circuit formed by C3 and D1. The generator voltage will be balanced against the capacitor voltage and C3 will remain charged.

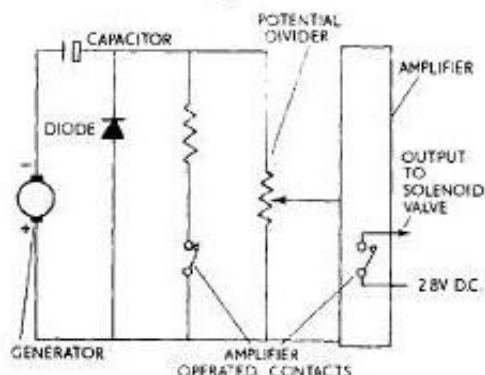

Fig. 3. Basic skid detection circuit

Skid detection

5. When the brake is applied the aircraft wheel begins to decelerate and the generator voltage will fall, resulting in C3 discharging via relay contacts RL1/A and resistor R7. The rate of discharge of C3 is determined by the difference between the capacitor and generator voltages, increasing as the wheel deceleration increases. During normal decelerations this current flow is insufficient to build up an effective +ve potential across the input to the amplifier. During incipient skid conditions, however, this potential increases and when this increased voltage input to the amplifier, via the wiper of potentiometer VR1, reaches a predetermined level, the amplifier operates relay RL1. A 28V d.c. is thereby switched to the solenoid valve and the hydraulic pressure to the brake released.

Amplifier

6. The two stage amplifier, comprising transistors VT1 and VT3, functions as a switch and is operated by a predetermined level of input voltage. The first stage containing T1 is connected as an emitter follower

and arranged for impedance matching. The second amplifying stage contains T3 with RL1 forming the collector load. The Zener diode ZD1 and resistor R3 are included in the base circuit to prevent the base voltage of VT1 rising above a level which would result in damage to the transistors.

Memory circuit

7. When the amplifier operates, relay RL1 is energized; contacts RL1/B close to complete the 28V d.c. supply to the solenoid valve, and contacts RL1/A open to switch R7 out of the circuit. C3 will therefore discharge through VR1 and the time constant of the circuit increased. The effect of this is to maintain the amplifier in an operated condition and RL1 energized for a longer period than with R7 in circuit. The purpose of this is to allow time for the wheel to accelerate again before the brake pressure is re-applied. The length of this brake pressure hold-off or "memory" period is determined by the initial wheel speed, i.e. the voltage to which C3 is charged; being longer when the wheel speeds are high, and shortening as the braking progresses. The "memory" is cancelled when the wheel accelerates again and current in the capacitor C3 circuit is reversed.

SERVICING

8. The control box second line servicing is restricted to examination for damage, corrosion and security of attachment, and functional testing. Unserviceable units should be returned to a repair depot.

Testing (using Functional Tester)

9. This functional check, utilizing the Goodyear System Functional Tester Part No. E.31060 may be carried out with the control box *in situ* on the aircraft.

- (1) Disconnect the Cannon plug from the front of the control box.
- (2) Connect Functional Tester both to the control box Cannon plug and to the aircraft cable connector.

Sensitivity test

10. Check the sensitivity of the control box as follows:—

- (1) Select PORT or STARBOARD channel on the Functional Tester.

RESTRICTED

- (2) Select SENSITIVITY.
- (3) Adjust the SET VOLTS CONTROL TO GIVE $\langle 2.5 \text{ to } 3 \rangle$ volts.
- (4) The INDICATOR lamp of the Tester should flicker at the sensitivity setting of between $\langle 2.5 \text{ and } 3 \rangle$ volts.
- (5) If the INDICATOR lamp flickers outside this range, or remains constantly ON, or the INDICATOR lamp does not operate, the control box is unserviceable and should be renewed.

Functional test

11. To check the correct functioning of the control box proceed as follows:—

- (1) Select PORT or STARBOARD channel on the Functional Tester.
- (2) Select FUNCTION.
- (3) Adjust generator speed to 5000 r.p.m.
- (4) Depress the FAST SKID SWITCH until the INDICATOR lamp goes OFF.
- (5) The INDICATOR lamp should remain ON longer than the MEMORY lamp. If the INDICATOR lamp goes OFF before the MEMORY lamp, or remains ON whenever the generator is running, or fails to operate, the control box is unserviceable and should be renewed.

Testing (without Functional Tester)

12. The control box may also be bench tested after removal from the aircraft when a Functional Tester is not available. The procedure is as follows:—

Sensitivity test

13. (1) Connect a 24V d.c. supply to pole J and A of the control box, ensuring that the positive lead is connected to pole J.
- (2) Connect a 0–10 volts, variable d.c. supply to the control box test points—positive to pole C (port) and pole F (stbd.), common negative to pole A.

- (3) Connect a multimeter between pole D and pole A (port), or between pole E and pole A (stbd.). Increase voltage to test points until the meter indicates. This should occur at a test voltage of $\langle 2.5 \text{ to } 3V \text{ d.c.} \rangle$

Note . . .

It is important that the applied voltage must always be increased to the test point from zero. Multimeter should be set to read 30V d.c.

Functional test

14. With the 24V d.c. supply still connected, and with the multimeter still in the appropriate circuit, apply 50V d.c. to pole B (port) or pole C (stbd.) ensuring that the positive lead is connected to pole A.

- (1) By means of a change-over switch disconnect pole B (port) or pole C (stbd.) from the negative 50V d.c. supply and connect it to earth (pole A).
- (2) The duration of operation of the control box, after the 50V d.c. has been removed (indicated by the meter), is the memory period of the channel and should be greater than 3 seconds.

Note . . .

The control box must respond to a voltage of $\langle 2.75V \text{ d.c. } \pm 0.25V \rangle$ at a room temperature at $20^{\circ}C \pm 5^{\circ}C$ when the sensitivity setting is correct, and the output signal must be maintained for a period in excess of 3 seconds if the control box is functioning correctly.

Storage

15. The sensing circuits of the control box utilize electrolytic capacitors and some deterioration of the dielectric film can be expected when electrolytics are stored without a polarizing voltage. For this reason when the control box is stored or unused it should be subjected to the following procedure at specified intervals:—

- (1) Apply a voltage of 105V d.c. to the control box in series with a resistance of 10 kilohms and a multimeter Type 12889 (or equivalent) initially set on the 10 mA d.c. scale. The positive pole of the supply should be connected to pin A of the control box, the negative to pin G.

Caution . . .

Care should be taken to connect the supply as indicated in the above paragraph as reversal of the supply polarity will damage the electrolytic capacitors.

(2) The applied voltage should be maintained until the current drops to below 350 microamps or for a period of 30 minutes whichever is the shorter,

the meter range being reduced as the current falls.

(3) If no drop in current is observed during this period the capacitors are suspect and should be renewed.

This completes the reforming operation for the capacitors in the Starboard Sensing Circuit. For the Port Circuit the foregoing should be repeated with the d.c. voltage connected between pins A and B with the negative pole to pin B.▶

This file was downloaded
from the RTFM Library.

Link: www.scottbouch.com/rtfm

Please see site for usage terms,
and more aircraft documents.

