

Chapter 14

NAVIGATION LAMP, HEAD, TYPE B

LIST OF CONTENTS

	Para.		Para.
Introduction	1	Servicing	7
Description	2		

LIST OF ILLUSTRATIONS

	Fig.		Fig.
Head navigation lamp, Type B	1	Sectional drawing of lamp	2

LEADING PARTICULARS

Head navigation lamp, Type B	Stores Ref. 5CX 678
Screen cap	Stores Ref. 5CX 2160
Glass, clear	Stores Ref. 5CX 500
Filament lamp, 24-volt, 10-watt	Stores Ref. 5L X952276
Weight (lamp and base)	4.5 oz.
Overall length	3 in.

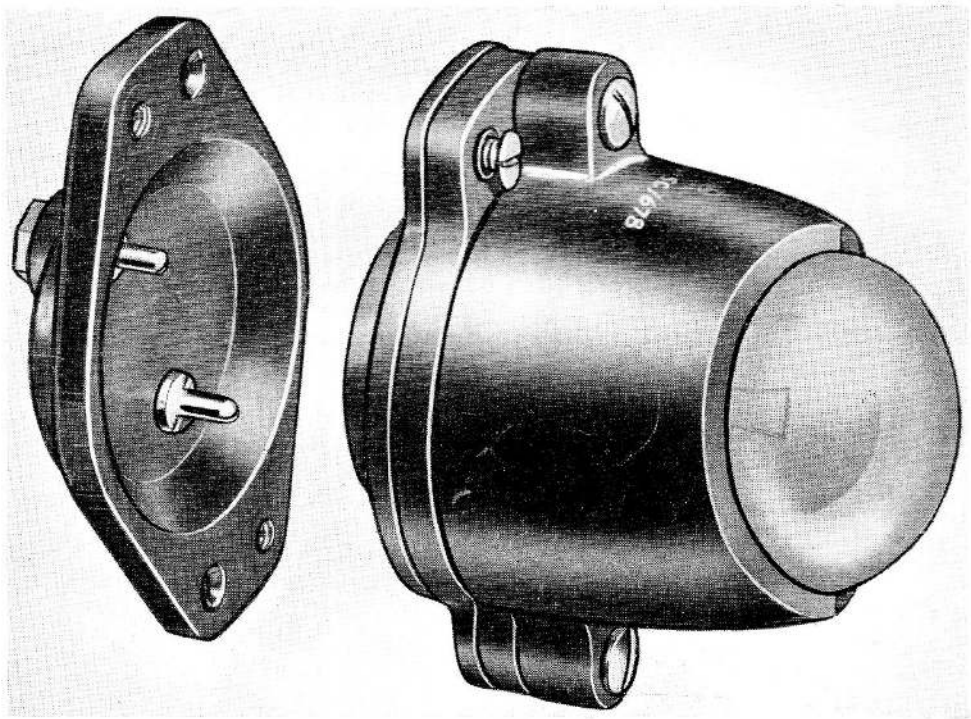

Fig. 1. Head navigation lamp, Type B

RESTRICTED

Introduction

1. Aircraft flying at night must be equipped with lights to indicate their presence and position, and as far as possible their direction of flight. These lamps are controlled by suitable switches in the cockpit. The Type B head lamp is intended for use at the nose of the aircraft fuselage. A general chapter on navigation lights will be found in A.P.4343, Vol. 1, Sect. 21.

DESCRIPTION

2. The head lamp, Type B, is made in two assemblies, the lamp proper, which is removable, and the base socket, which is fixed to the airframe. Two csk/hd. screws secure the lamp to the base socket. Electrical connection between the two assemblies is by plug pins and sockets (*fig. 1*).

3. The socket for the filament lamp (*fig. 2*) is formed in a base plate having the two contacts supported on flat leaf springs behind it. The leaf springs are C-shaped and fixed by a screw and socket insert. The socket has a thread which screws into the base and a hexagonal collar. The socket inserts project

through an inner cover which is fixed behind the contact springs and secured by two screws, not shown in the illustration.

4. The screen cap is secured to the base plate by two slotted nuts which screw on to studs moulded into the base plate. This cap is cut away between two vertical planes 110 deg. on each side of the forward direction, giving a total angle of 220 deg. The clear glass dome is held in position by the screen cap, a waterproof joint being made by means of a rubber jointing washer.

5. The plug base moulding socket (Stores Ref. 5CX/501) is shaped to fit the base of the lamp. The two plug pins are mounted loosely in it so that they can align readily with the socket inserts. The base is secured to the fuselage by two 4 B.A. csk/hd. screws and the terminal connections are made behind this base.

6. The light source is a 24-volt, 10 watt filament lamp having a small bayonet cap. This lamp has a small straight coil filament, arranged to be vertical when the lamp is in its holder so as to give a sharp cut-off at the edges of the screen.

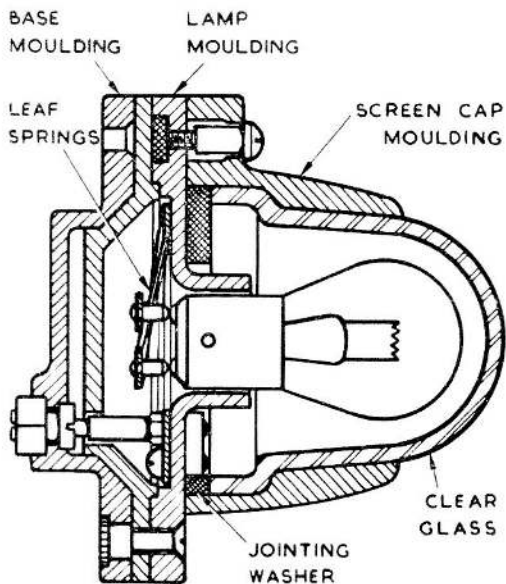

Fig. 2. Sectional drawing of lamp

SERVICING

7. Check that the lamp glass is clean inside and out. Remove the screen by releasing the two slotted nuts which hold it. Clean the glass and inspect the rubber jointing washer (Stores Ref. 5CX/502) renewing it if necessary. If the filament bulb glass shows signs of undue blackening it should be renewed. Remove the two screws securing the lamp to the socket base and lift off the lamp. Inspect the contacts and clean them as necessary carefully opening the contact pins to ensure good contact.

8. Replace the lamp on to the socket base and secure with the two csk/hd. screws. Insert the filament bulb in the holder and switch on to check its operation. Replace the glass with its sealing washer and secure by replacing the screen cap and tightening the securing nuts. Finally, check again the operation of the filament and see that the glass is clean.

RESTRICTED

This file was downloaded
from the RTFM Library.

Link: www.scottbouch.com/rtfm

Please see site for usage terms,
and more aircraft documents.

