

ADMIRALTY
AIR MINISTRY

Chapter 15

COCKPIT LAMP, MK. IA

LIST OF CONTENTS

	Para.
Introduction	1
Description	3
Installation	6

LIST OF ILLUSTRATIONS

	Fig.
Cockpit lamp, Mk. IA	1
Interior of cockpit lamp	2

LEADING PARTICULARS

Cockpit lamp, Mk. IA ...	Stores Ref. 5C/446
Diameter of case	3 in.
Weight	7 oz.
Filament lamp—	
12-volt, 6-watt (S.B.C.) ...	Stores Ref. 5L/X952254

ELECTRICAL MANUAL, STATIC CONSUMER EQUIPMENT
(AIRBORNE)

This is A.L. No. 21 to A.P. 4343E, Vol. 1

Section 7. List of Chapters: delete "(to be issued later)" after the title of Chapter 15, and write "(A.L. 21)", in the outer margin against the deletion. Insert this Chapter 15 to follow Chapter 2, and record the incorporation of this A.L. in the Amendment Record Sheet.

RESTRICTED

Introduction

1. The amount of illumination in cockpits should be only sufficient to allow the instruments and controls to be seen easily. Excess of light is undesirable, since if the pilot looks from a brightly lighted interior to comparative darkness outside, his eyes will take time to adapt themselves to the difference.

2. The cockpit lamps are therefore arranged so that the light they give can be used as effectively as possible and so that a minimum of stray light is produced.

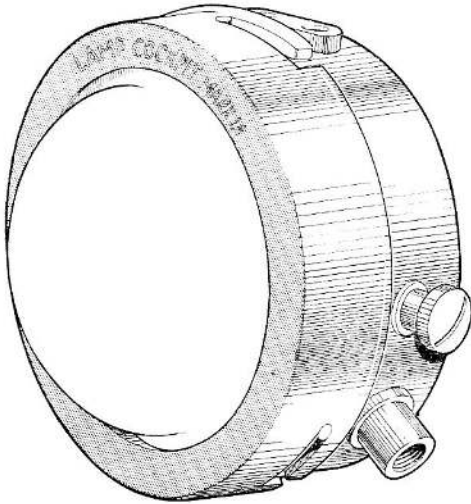

Fig. 1. Cockpit lamp, Mk. 1A

DESCRIPTION

3. The cockpit lamp, Mk. 1A (fig 1), has a domed front of opal glass, secured by a bezel ring. A switch is incorporated in the lamp, and a socket is fitted in the top of the case for supplying an inspection lamp or similar circuit.

4. The interior of the lamp is shown in fig. 2. The switch consists of two leaf springs bridged by a brass bobbin mounted on a switch rod but insulated from it. The switch rod passes right across the case, and terminates in a button outside the case on each side. The circuit is closed when the

rod is pushed to the left, and when it is pushed to the right an ebonite bobbin takes the place of the brass one. The leaf springs engaging in the bobbins locate the switch in either position.

5. The upper leaf spring is connected to the left-hand socket contact, and the lower spring and the right-hand socket are connected to the lamp. The supply leads to the lamp are connected under the screws on the socket terminals, so that the socket is supplied directly from the leads and the lamp is controlled by the switch.

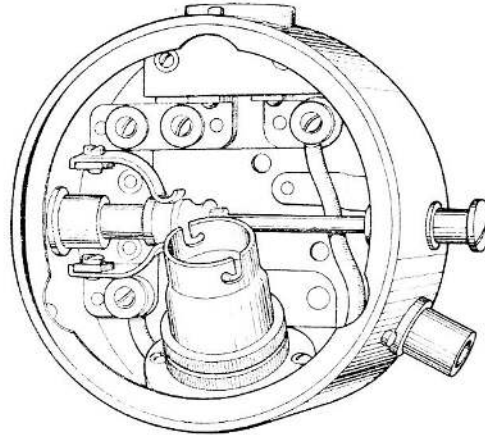

Fig. 2. Interior of cockpit lamp

INSTALLATION

6. When the lamp is connected up, the cores of the cable should be separated and the end of the braiding tightly bound with waxed thread. A piece of Systoflex tubing of 3mm. bore and 1.25 in. long should be slipped over each lead up to the binding. The end of the cable should then be passed through the bush in the lamp case, and the terminating rings supplied with the lamp clipped on to the ends of the leads, one lead being 2.5 in. and the other 1.75 in. long. Both wires should be passed under the clip at the back of the case, the shorter one connected to the right-hand socket terminal and the longer one to the left-hand terminal.

RESTRICTED

Introduction

1. The amount of illumination in cockpits should be only sufficient to allow the instruments and controls to be seen easily. Excess of light is undesirable, since if the pilot looks from a brightly lighted interior to comparative darkness outside, his eyes will take time to adapt themselves to the difference.

2. The cockpit lamps are therefore arranged so that the light they give can be used as effectively as possible and so that a minimum of stray light is produced.

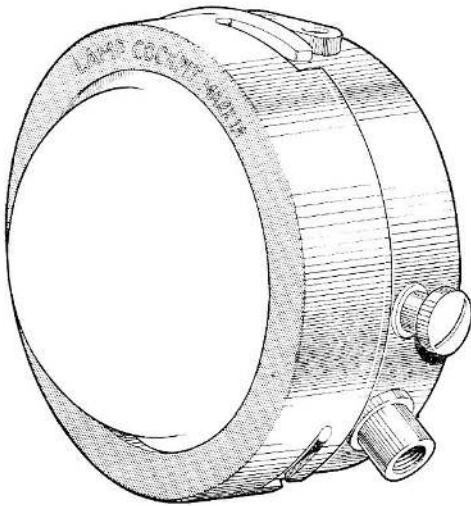

Fig. 1. Cockpit lamp, Mk. 1A

DESCRIPTION

3. The cockpit lamp, Mk. 1A (*fig 1*), has a domed front of opal glass, secured by a bezel ring. A switch is incorporated in the lamp, and a socket is fitted in the top of the case for supplying an inspection lamp or similar circuit.

4. The interior of the lamp is shown in *fig. 2*. The switch consists of two leaf springs bridged by a brass bobbin mounted on a switch rod but insulated from it. The switch rod passes right across the case, and terminates in a button outside the case on each side. The circuit is closed when the

rod is pushed to the left, and when it is pushed to the right an ebonite bobbin takes the place of the brass one. The leaf springs engaging in the bobbins locate the switch in either position.

5. The upper leaf spring is connected to the left-hand socket contact, and the lower spring and the right-hand socket are connected to the lamp. The supply leads to the lamp are connected under the screws on the socket terminals, so that the socket is supplied directly from the leads and the lamp is controlled by the switch.

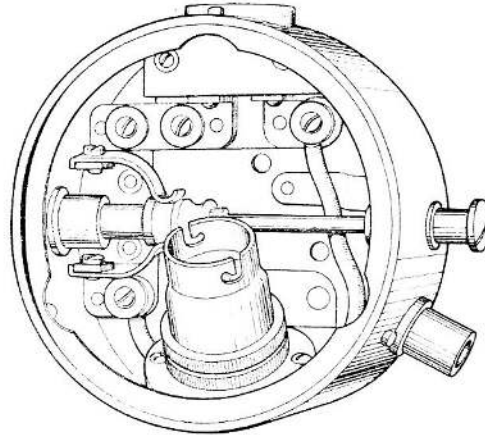

Fig. 2. Interior of cockpit lamp

INSTALLATION

6. When the lamp is connected up, the cores of the cable should be separated and the end of the braiding tightly bound with waxed thread. A piece of Systoflex tubing of 3mm. bore and 1.25 in. long should be slipped over each lead up to the binding. The end of the cable should then be passed through the bush in the lamp case, and the terminating rings supplied with the lamp clipped on to the ends of the leads, one lead being 2.5 in. and the other 1.75 in. long. Both wires should be passed under the clip at the back of the case, the shorter one connected to the right-hand socket terminal and the longer one to the left-hand terminal.

RESTRICTED

This file was downloaded
from the RTFM Library.

Link: www.scottbouch.com/rtfm

Please see site for usage terms,
and more aircraft documents.

