

Chapter 40**SINGLE MINIATURE PILLAR LAMPS****LIST OF CONTENTS**

| | <i>Para.</i> |
|-----------------------------|--------------|
| <i>Introduction</i> | 1 |
| Description | 2 |
| Installation | 5 |
| Servicing | 6 |

LIST OF ILLUSTRATIONS

| | <i>Fig.</i> |
|---|-------------|
| <i>Single miniature pillar lamp</i> | 1 |
| <i>Sectional view</i> | 2 |
| <i>Installation diagram</i> | 3 |

LEADING PARTICULARS**Single miniature pillar lamp, $\frac{1}{2}$ in. stem,**

| | |
|---|--------------------------|
| <i>Thorn Part No. 80/10/0855 (black finish)</i> | <i>Ref. No. 5CX/5364</i> |
| <i>Thorn Part No. 80/10/1594 (grey finish)</i> | <i>Ref. No. 5CX/5491</i> |

Single miniature pillar lamps, 1 in. stem

| | |
|---|--------------------------|
| <i>Thorn Part No. 80/10/0678 (black finish)</i> | <i>Ref. No. 5CX/5363</i> |
| <i>Thorn Part No. 80/10/1593 (grey finish)</i> | <i>Ref. No. 5CX/5490</i> |

*Spares**Lamp carrier, red filter (filament housing)*

| | |
|--|----------------------------|
| <i>Thorn Part No. 80/10/1147 (black finish)</i> | <i>Ref. No. 5CX/5365</i> |
| <i>Thorn Part No. 80/10/1147 (grey finish)</i> | <i>Ref. No. 5CX/</i> |
| <i>Filament lamp, special miniature, 28 volt, 0.04 amp</i> | <i>Ref. No. 5L/9959118</i> |

RESTRICTED

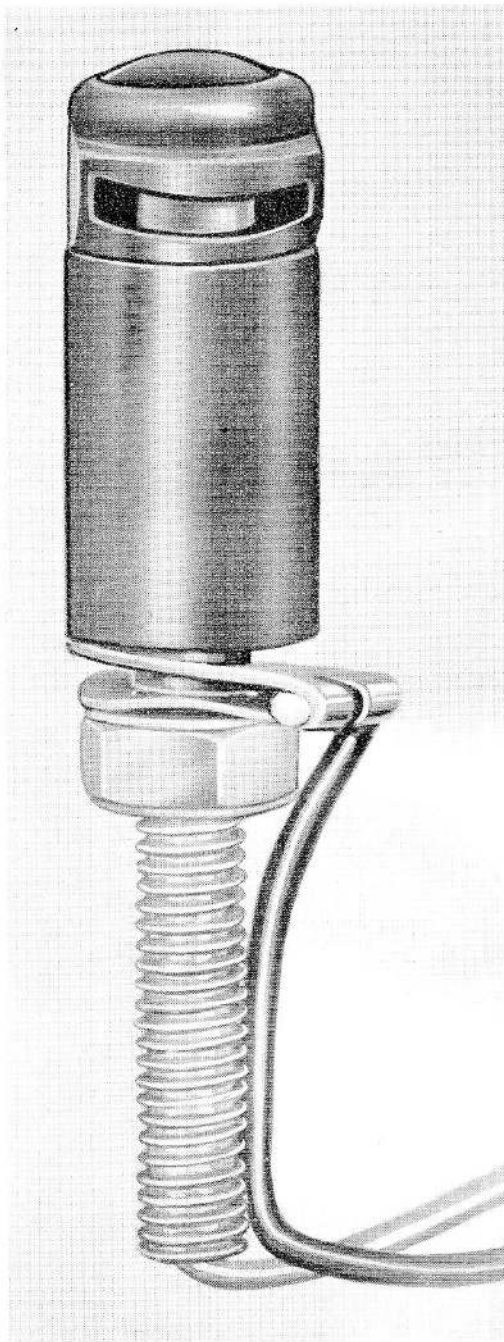

Fig. 1. Single miniature pillar lamp

Introduction

1. The single miniature pillar lamps are used in many types of aircraft to provide instrument panel illumination. Two lengths of threaded stem are available to cater for both thick and thin panels, and the lamps are provided in black or grey finish. The Thorn Part No. may also be shown with added suffixes, i.e. 80/10/1147/Red/Grey, which are used to indicate the filter colour of the lamp carrier and the colour of the external finish.

DESCRIPTION

2. A general view of the lampholder is shown in fig. 1 and a sectional view in fig. 2. The lamp carrier, which is made of brass, has an angled light aperture rather similar to the slot in a pillar box, which supplies the required amount of light divergence to illuminate the respective instrument. A key way in the wall of the housing locates with a key machined into the lamp body; this ensures that the distribution of light is accurately determined.

3. The lamp body is machined from light alloy material and has an integral threaded stem by which it is attached to the panel. This threaded stem has a hole running throughout its length to permit the passage of the connecting lead to a spring-loaded centre contact; this centre contact is insulated from the body of the lamp.

4. A beryllium copper spring collar encircles the lamp body. A small rivet attached to one end of this spring passes through a hole in the body wall and engaged with a groove cut circumferentially in the lamp housing. This ensures that a definite pull is required to separate the housing from the body.

INSTALLATION

5. An installation diagram is shown in fig. 3 and clearly indicates the dimensions of the lamp and the area of illumination. The threaded stem shown in the diagram may be either 1 in. or $\frac{1}{2}$ in. in length according to the thickness of panel to which the lamp is to be fitted.

RESTRICTED

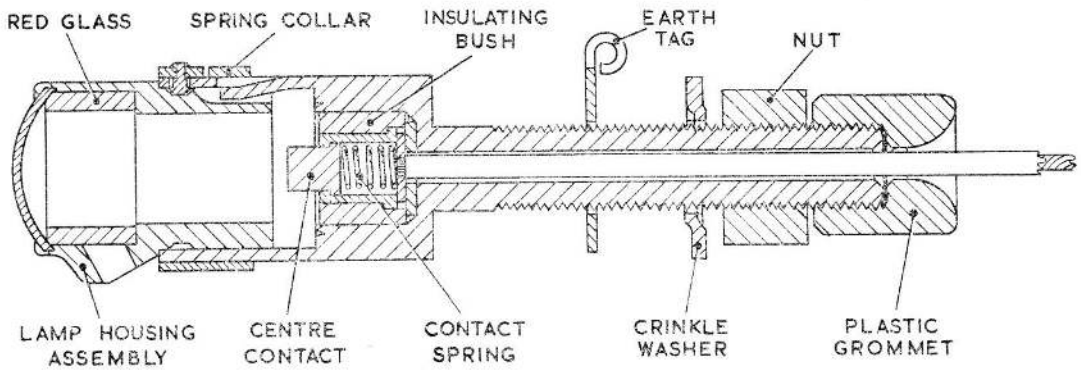

Fig. 2. Sectional view

SERVICING

6. Servicing is restricted to the renewal of defective parts of the lamp, no repair is possible. Renewal of the filament lamp is achieved by removing the lamp housing and withdrawing the filament lamp; the new lamp is merely pushed into the housing where

it is retained by a spring circlip. The security of the filament carrier in the lamp pillar should be periodically checked, and should require a pull of not less than 2 lb. to remove it. Loose carriers should be renewed, and if this fails to give a secure fit the complete assembly should be renewed.

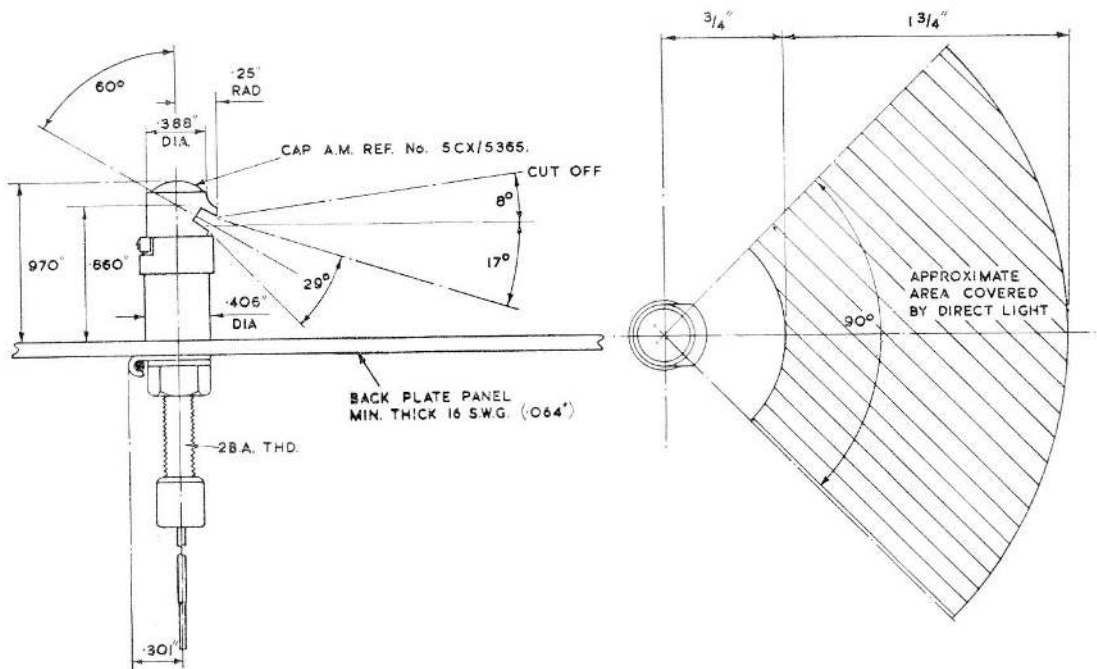

Fig. 3. Installation diagram

This file was downloaded
from the RTFM Library.
Link: www.scottbouch.com/rtfm

Please see site for usage terms,
and more aircraft documents.

