

Chapter 44

FUSELAGE NAVIGATION LAMP, THORN, TYPE FNL/50

LIST OF CONTENTS

	<i>Para.</i>		<i>Para.</i>
<i>Introduction</i>	1	Servicing	5
Description	2		

LIST OF ILLUSTRATIONS

	<i>Fig.</i>		<i>Fig.</i>
<i>Fuselage navigation lamp, Type FNL/50</i>	1	<i>Sectional view</i>	2

LEADING PARTICULARS

<i>Fuselage navigation lamp, FNL/50</i>	<i>Ref. No.</i> 5CX/5315
<i>Length</i>	5.85 in.
<i>Breadth</i>	4.70 in.
<i>Weight</i>	13 oz.
<i>Lamp filament, 28-volt, 40 watt.</i>	5L/9952445
<i>Electrical connections</i>	4B.A. terminal screws

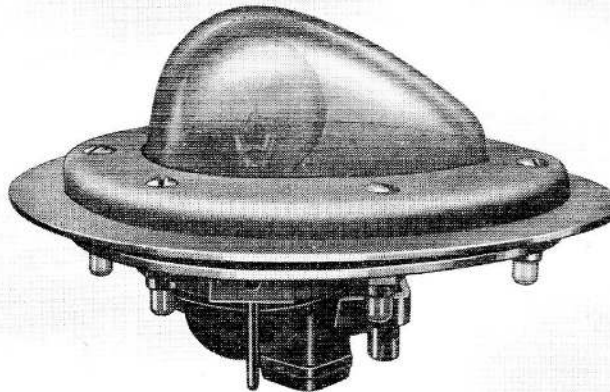

Fig. 1. *Fuselage navigation lamp, Type FNL/50*

Introduction

1. The fuselage navigation lamp, FNL/50, may be mounted on the top or underneath the fuselage of pressurised aircraft. It can be serviced in the normal manner from the outside when the aircraft is on the ground, or from within the fuselage during flight without risk to pressurisation.

DESCRIPTION

2. A general external view of the lamp is shown in fig. 1 while a sectional view is shown in fig. 2. The lamp filament is housed within a clear glass dome which is held in place by an aluminium clamping ring and sealed against air leakage by a double gasket.

RESTRICTED

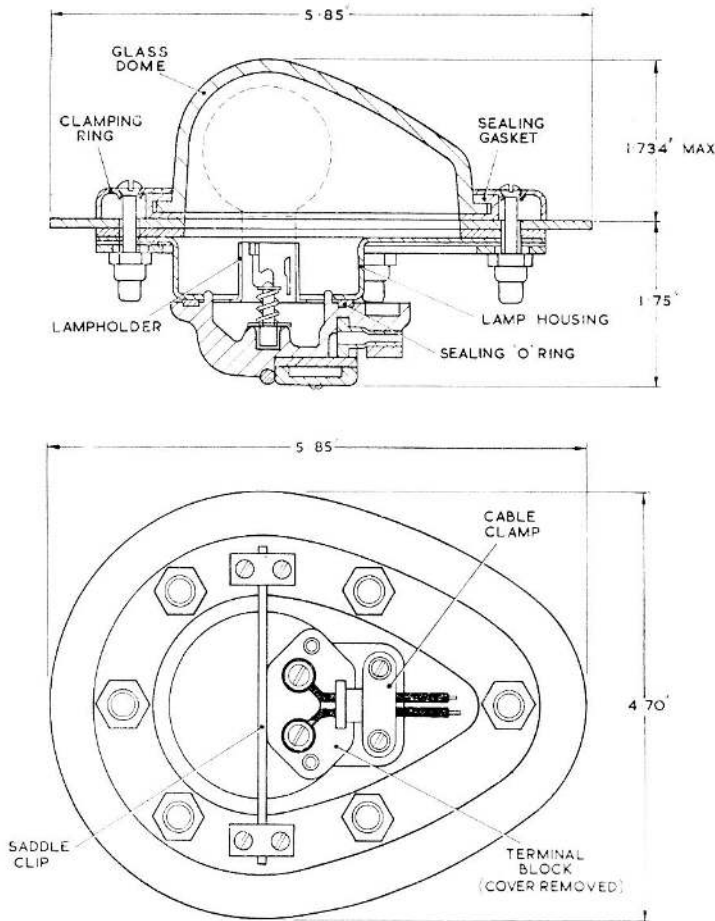

Fig. 2. Sectional view

3. The lampholder is carried on a moulded cap assembly which, when in position abuts a pressed metal housing, being retained in position by a spring saddle clip. The cable entry is made via a moulded rubber sealing grommet held between a moulded terminal cover and the cap assembly; a separate cable clamp is mounted on the cap independent of the terminal cover.

4. Sealing against loss of pressurisation is effected by a sealing gasket between the glass dome and the mounting slate and a rubber 'O' ring between the cap assembly and the lamp housing. The spring saddle clip provides the pressure for sealing in the case of the cap assembly while an alum-

inum alloy clamping ring and six 2 B.A. screws provide the sealing pressure for the glass dome.

SERVICING

5. The glass dome should be examined and cleaned, if necessary, both inside and out; it may be removed by releasing the six 2 B.A. screws retaining the clamping ring. If the filament lamp shows signs of undue blackening, it should be renewed to prevent failure during operational periods. The ends of cables should be examined for signs of damage and connections checked for security and freedom from corrosion.

RESTRICTED

This file was downloaded
from the RTFM Library.
Link: www.scottbouch.com/rtfm

Please see site for usage terms,
and more aircraft documents.

