

## Chapter 46

### LANDING LAMP, HARLEY, TYPE 8ND

#### LIST OF CONTENTS

	Para.		Para.
<i>Introduction</i> ... ..	1	<i>Electrical connections</i> ... ..	8
<b>Description</b>		<b>Servicing</b>	
<i>Outer housing</i> ... ..	2	<i>Renewing a bulb</i> ... ..	10
<i>Operating mechanism</i> ... ..	3	<i>Renewing a lens</i> ... ..	13
<i>Filament housing</i> ... ..	5	<i>Renewing front glass</i> ... ..	14
<i>Filament lamp</i> ... ..	7	<i>Operation checks</i> ... ..	16

#### LIST OF ILLUSTRATIONS

	Fig.		Fig.
<i>Harley landing lamp, Type 8ND</i> ... ..	1	<i>Installation drawing</i> ... ..	3
<i>Circuit diagram</i> ... ..	2		

#### LEADING PARTICULARS

<b>Landing lamp, Harley, Type 8ND (complete)</b>	... Ref. No. 5CX/5214
<b>(lamp only)</b>	... Ref. No. 5CX/5379
<i>Filament lamp (special cap), double filament, 280/280 watts</i> ... ..	... Ref. No. 5L/9959702
<i>Front glass</i> ... ..	... Ref. No. 5CX/5062
<i>Lens</i> ... ..	... Ref. No. 5CX/5058
<i>Operating unit (Plessey actuator CZ53681/11C)</i> ... ..	... Ref. No. 5W/2836
<i>Extended angle</i> ... ..	... 90 deg.
<i>Weight</i> ... ..	... 10.5 lb

#### Introduction

1. The Harley, Type 8ND landing lamp fits into 10½ in. dia. aperture in the aircraft wing or fuselage. It is operated by an electrical power unit or actuator.

#### DESCRIPTION

##### Outer housing

2. The outer housing is a machined casting which incorporates the mounting flange and a bracket to support the actuator trunnion attachment. Attached to the cover are three terminal blocks to which actuator control cables and filament cables are attached. The

mounting flange has a number of lightening holes and carries the pivot bearings which support the retractable filament housing. A rear cover is attached by screws to the outer housing.

##### Operating mechanism

3. Viewed from the front, the right-hand journal of the filament housing carries the actuating lever to which the forked eye, ram or plunger end of the actuator is connected. The trunnion end of the actuator is pivoted to a lever which in turn pivots on a bracket on the outer housing casting. This arrange-

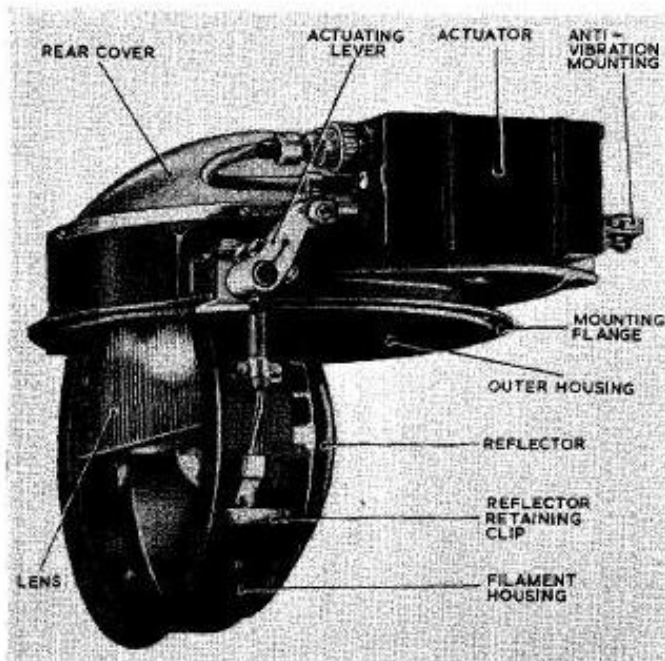

Fig. 1. Harley landing lamp, Type 8ND

ment permits the actuator to move as a solid link for the final  $\frac{1}{8}$  in. of retracting motion, and any slackness in the operating linkage is absorbed by the compression of a spring attached to the trunnion pivot lever. The small movement of this lever also operates a snap switch connected in series with the filament relays (fig. 2).

4. The actuator limit switches and brake adjustments are set by the manufacturers and should not normally require alteration in service. Details of the actuator will be found in the relevant chapter of A.P.4343D, Vol. 1, Book 3, Sect. 14.

#### Filament housing

5. This is the moving part of the lamp and consists of the outer frames casting which carries the lens frame, reflector and filament. The front glass is bedded into sealing compound and backed by a sealing ring which is held in place by the lens frame in turn secured by screws to the outer frame casting. The lens frame has a horizontal cross member which carries the fixed half of the lamp holder clamp. The lens is held in the upper half of the lens frame by three clips fitted with rubber pads which allow for expansion of the lens.

6. The lamp cap is held in a clamp secured

by two screws, and is accurately positioned when the locating pin on the lamp cap fits into the hole in the fixed half of the clamp. The reflector fits into the lens frame to which it is secured by three spring clips bearing behind the front rim of the reflector.

#### Filament lamp

7. The light source of this lamp has two filaments each rated at 280 watts. The main filament is accurately positioned at the focal point of the reflector, whilst the secondary or auxiliary filament is a little to the rear and above the main filament. The secondary filament produces a more dispersed beam, for taxiing. The filament bulb cap has a locating pin at the side and has three 2 B.A. terminal connections at its base. These terminals are colour coded:—

Red	...	...	...	Main filament
Yellow	...	...	...	Auxiliary filament
Blue	...	...	...	Negative

#### Electrical connections

8. The filament and the actuator are supplied from the 28-volt d.c. source. The filament control is through a centre-off, two-way switch which allows selection of main or auxiliary filament for landing or taxiing. The terminals on the cover of the lamp are in standard 19-amp S.B.A.C. blocks (two

RESTRICTED

2-way and one 3-way) to which is connected the flexible cable to the retractable lamp housing. Connection to the actuator is by a six-pole plug and socket of which only three pins are used. Cockpit control of the actuator is by a 2-way switch selecting "up" or "down" for the filament housing.

9. The actuator is controlled by a 2-way switch in the cockpit. From the lamp terminals a short flexible cable having a stan-

dard Breeze type plug connects to the actuator.

### SERVICING

#### Renewing a bulb

10. Examine the filament lamp glass for white streaks (which indicate leaking glass seal) and for blackening. If a new bulb is required, actuate the lamp housing to its fully extended position. Unclip the three spring clips retaining the reflector and with-

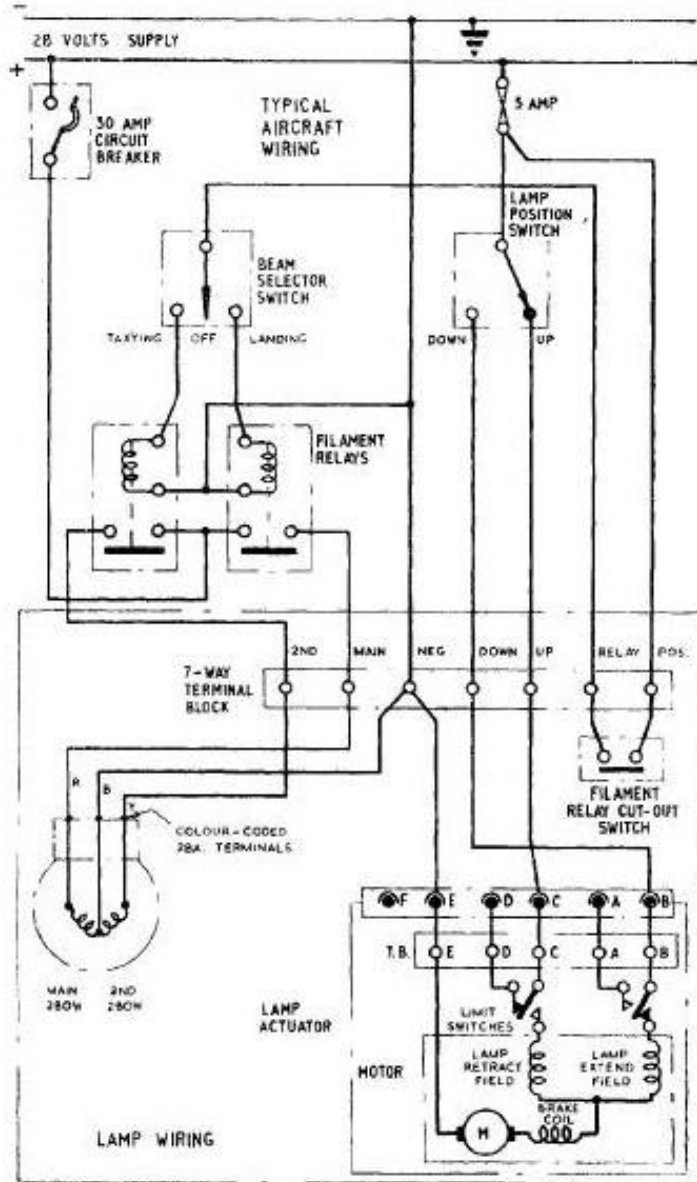

Fig. 2. Circuit diagram

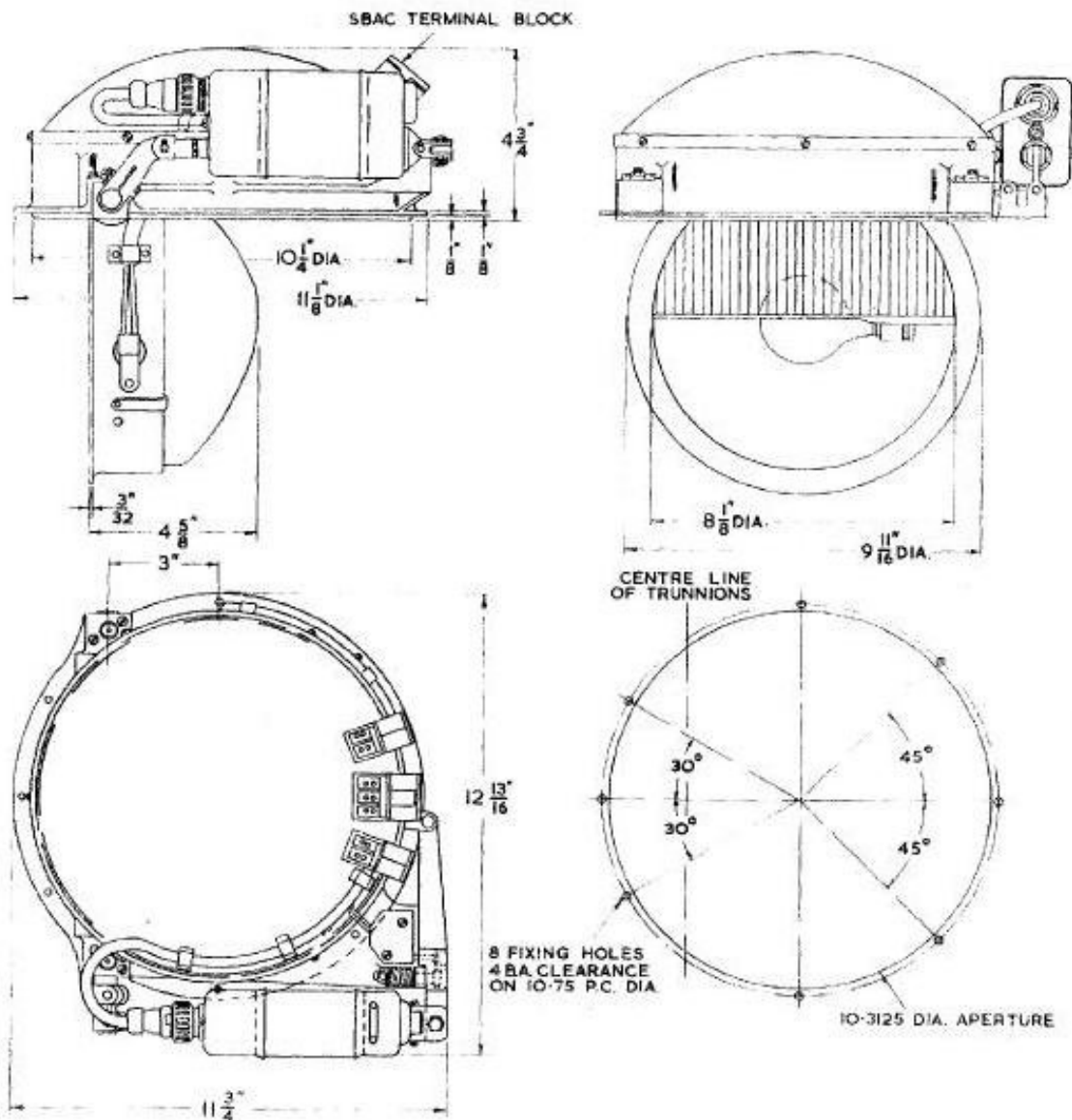

Fig. 3. Installation drawing

draw the reflector, placing it face downwards on a flat surface. Disconnect the three terminals of the bulb and lift off the cables. Remove the half clamp retaining the bulb by unscrewing the two clamping screws.

11. Clean the inside of the lamp housing with a soft cloth; do not use a polish and avoid finger printing the reflector, front glass and lens. If these items are dirty, use soapy water and dry with a clean cloth.

12. When fitting the new bulb see that it is

correctly positioned by engagement of the locating pin. Ensure that the cables are replaced to the correct colour coding, that terminal washers are in place and do not overtighten the nuts. Replace the reflector and secure with the three retaining clips.

#### Renewing a lens

13. Proceed as in para. 10 to 12 and then remove the three clips and rubber pads which secure the lens. Fit the new lens with its flat side towards the bulb and replace the clips

**RESTRICTED**

complete with the rubber pads. Re-assemble the filament lamp and reflector.

#### Renewing front glass

14. Remove the lamp from the aircraft and place on a workbench. Remove the reflector and bulb. Remove six 4 B.A. screws securing the back cover and lift it clear of the outer housing. Remove the cable clip immediately over the top lens clip and push the cable to one side. Remove the top lens clip. Remove two 4 B.A. round-head screws, nuts and washers securing the lens frame to the filament housing frame. Unclip the cable and withdraw it clear of the lens frame. Withdraw the lens frame complete with the lens. Remove the front glass and sealing ring.

15. Clean away all surplus sealing compound from inside the lamp and fit the new glass. Pack the space between the glass and the wall of the casting with sealing strips

(Ref. No. 5CW/5085). Replace or renew the sealing ring (Ref. No. 5CW/5063) and secure in position by replacing the lens frame assembly. Push the cable through the hole in the filament housing and replace the cable clips. Replace the bulb and reflector, checking for correct location of the bulb. Replace the back cover.

#### Operation checks

16. If the lamp can be operated on the bench, see that the spring loaded damper is functioning. After renewing components of the lamp on the aircraft operate a few times and check that no fouling occurs, paying particular attention to the exposed cable assembly on the filament housing frame. The filament should be switched on for short periods and the lamp retracted to check that the final retracting motion breaks the lamp relay circuit. The general chapter on landing lamps is in A.P.4343, Vol. 1, Sect. 21.

This file was downloaded  
from the RTFM Library.

Link: [www.scottbouch.com/rtfm](http://www.scottbouch.com/rtfm)

Please see site for usage terms,  
and more aircraft documents.

