

Chapter 52

TAIL LAMP, TYPE C

LIST OF CONTENTS

				<i>Para.</i>					<i>Para.</i>
<i>Introduction</i>	1	Operation	4
Description	2	Servicing	5
Installation	3					

LIST OF ILLUSTRATIONS

				<i>Fig.</i>
<i>Tail lamp, Type C</i>	1
<i>Lamp, with cover removed</i>	2
<i>Angles of divergence</i>	3

LEADING PARTICULARS

					<i>Ref. No.</i>
Tail lamp, Type C	5CX/1257
<i>Blue glass</i>	5CX/1258
<i>Washer, circular section</i>	5CX/1259
<i>Washer, rectangular section</i>	5CX/1260
<i>Lampholders, S.B.C., Type B</i>	5CX/2680
<i>Lamp, filament, 24V, 6W</i>	5L/9952258
<i>Lamp, filament, 24V, 10W</i>	5L/9952276

Introduction

1. The tail lamp, Type C, an external view of which is shown in Fig. 1, provides two lighting services for night flying aircraft, namely: formation keeping and navigation. The formation light is blue and is only visible to other aircraft at approximately the same

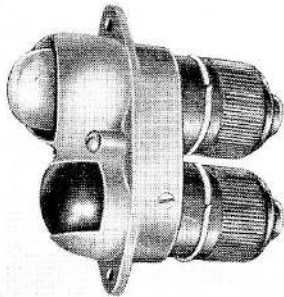

Fig. 1. Tail lamp, Type C

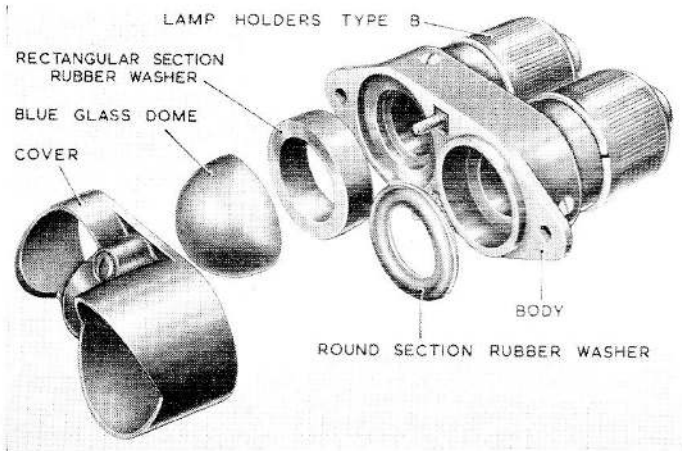

Fig. 2. Lamp, with cover removed

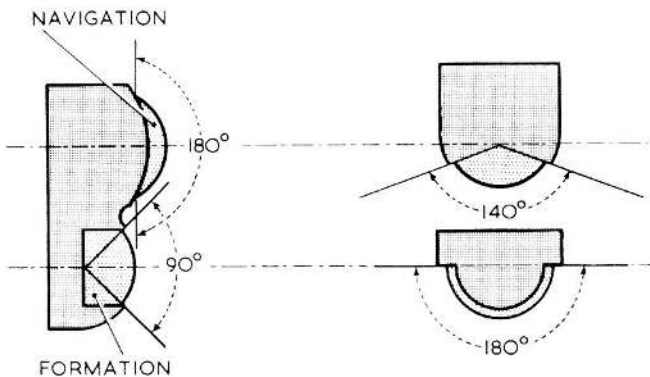

Fig. 3. Angles of divergence

level, but is not visible from the ground. The navigation light indicates the presence and position of the aircraft, and as far as possible its direction. The lamp is primarily used on Naval Aircraft.

DESCRIPTION

2. The tail lamp, Type C (fig. 2), consists of an aluminium alloy die cast body containing two standard S.B.C. lampholders, Type B. These two lampholders are held in position by 6 B.A. countersunk screws. A rectangular section rubber washer and blue glass dome fit over the formation filament lamp, both being fixed to the body by bostic adhesive. A circular washer fits over the neck of the navigation filament lamp and prevents ingress of moisture. An aluminium alloy die cast cover fits over the filament lamps and glass and retains these items in position, the cover being secured by two counterbored captive screws in the cover.

INSTALLATION

3. The lamp, normally fitted behind a transparent window, is mounted on the fin unit of the aircraft. The angular range of vision of this lamp is shown in Fig. 3. The lamp is secured in position by two 4 B.A. screws. Access to terminals of the lamp is obtained by unscrewing the moulded cover.

OPERATION

4. The filament lamps are operated independently. The formation light is operated through a switch and dimmer resistance. The navigation lamp is normally used in co-operation with a flasher unit, Type A, and a morse and steady switch.

SERVICING

5. Check the operation of lamps by a functional test. At specified periods remove the cover and clean the filter glass, refixing it with bostic adhesive. Renew any filament lamp showing signs of discolouration. Renew perished or damaged rubber washers. Inspect the lampholders for free movement of spring-loaded plungers and see that they are free from corrosion.

RESTRICTED

This file was downloaded from the RTFM Library.
Link: www.scottbouch.com/rtfm

Please see site for usage terms, and more aircraft documents.

