

Chapter 54

SIGNALLING LAMP, TYPE C

LIST OF CONTENTS

| | <i>Para.</i> | | <i>Para.</i> |
|--------------------------------|--------------|--------------------------------------|--------------|
| <i>Introduction</i> | 1 | <i>Bulb and reflector</i> | 8 |
| <i>Operation</i> | 2 | <i>Cover assembly</i> | 9 |
| Description | 3 | <i>Sights</i> | 10 |
| <i>Lampholder</i> | 4 | <i>Electrical connections</i> | 11 |
| <i>Shutter assembly</i> | 6 | Servicing | 12 |

LIST OF ILLUSTRATIONS

| | <i>Fig.</i> |
|--|-------------|
| <i>Signalling lamp, Type C</i> | 1 |
| <i>Lamp, exploded view</i> | 2 |
| <i>View showing shutter positions</i> | 3 |
| <i>Section view</i> | 4 |

LEADING PARTICULARS

| | <i>Ref. No.</i> |
|--|-----------------|
| Signalling lamp, Type C | 5A/4391 |
| <i>Cable complete with connector</i> | 5A/4427 |
| <i>Screen, green</i> | 5A/1151 |
| <i>Screen, red</i> | 5A/1152 |
| <i>Transport box</i> | 5A/4411 |
| <i>Filament lamp, 11V, 60W (prefocused located)</i> | 5L/9952515 |

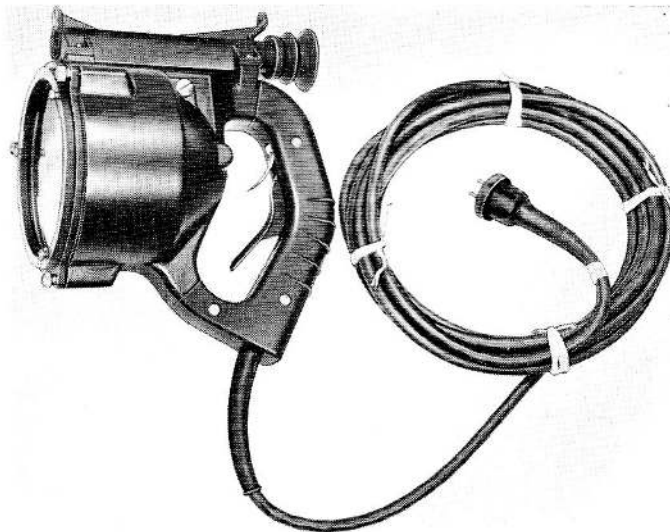

Fig. 1. Signalling lamp, Type C

Introduction

1. The lamp Type C (fig. 1), is a visual signalling lamp and may be used during the day or night. A double sighting arrangement is provided for focusing the beam on target. The signalling is effected by a shutter which operates over the filament lamp, and when covering the unblackened portion of it prevents light from falling on the reflector.

Operation

2. When signalling the lamp is connected to a source of supply and is held in both hands. For day signalling, the eye piece is held against one eye, the other eye is closed and the target held in the centre of the circle in the foresight. This ensures that the maximum beam intensity is thrown on to the target. The beam is visible up to approximately five miles in bright sunlight. For night use it is only necessary to use the top sight, the target being held at the apex of the triangular foresight and held in the centre of the circular rear sight.

DESCRIPTION

General

3. The lamp (fig. 2) consists of an aluminium die cast body and handle. A lampholder and reflector are contained in the lamp body together with the shutter assembly. A front cover assembly is secured to the front of the body by three screws. A shutter operating lever and filament lamp switch are located in the handle, and a target sighting arrangement is fixed to the top of the lamp. A section view of this lamp is shown in Fig. 4.

Lampholder

4. The lampholder is a two-pole type and designed to take a pre-focused filament lamp, it is in two parts consisting of a focus plate, to which is attached the lamp filament connections. These connections are contained in a metal housing which is secured to the focus plate against spring tension.

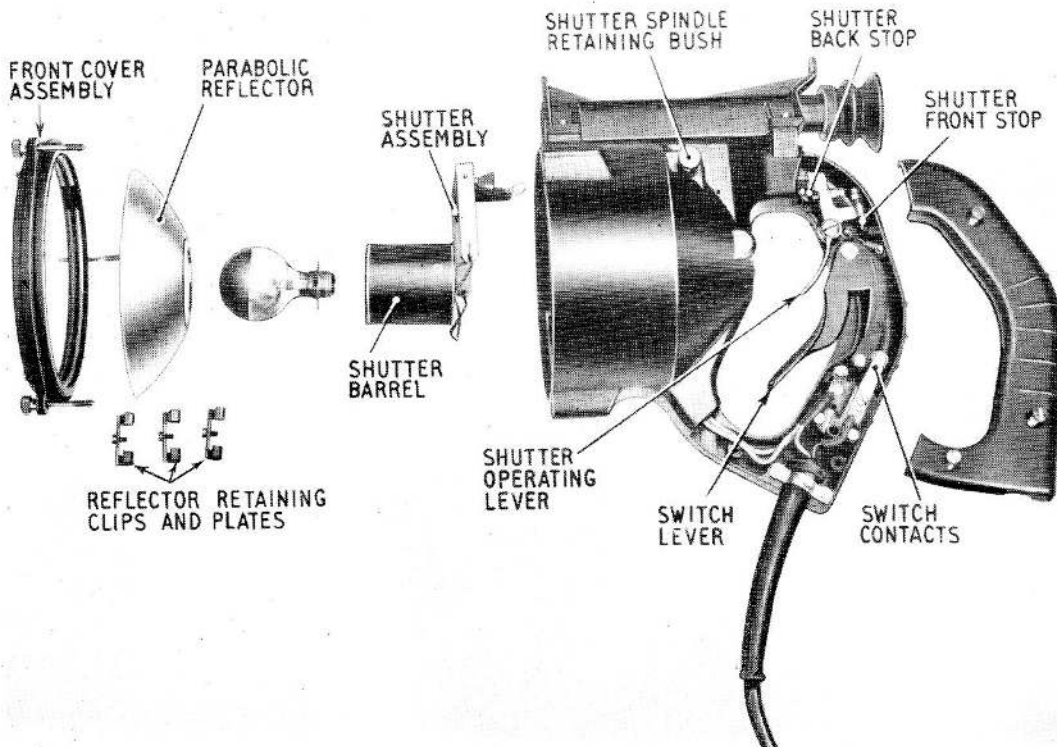

Fig. 2. Lamp, exploded view

RESTRICTED

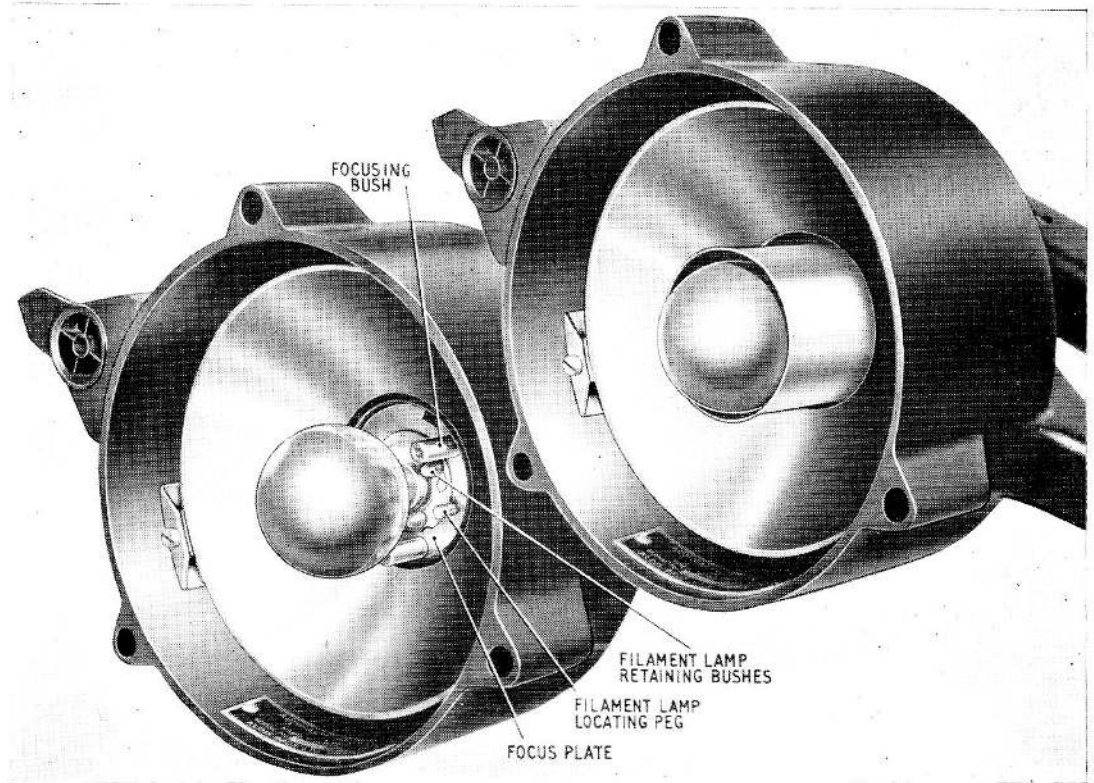

Fig. 3. View showing shutter positions

5. The lampholder is mounted by the focus plate on three carrier rods and held against spring tension by three bushes. By individual adjustment of these bushes (*fig. 3*), the filament lamp can be set to its correct focus position. Three retaining bushes spaced on the focus plate secure the bulb in position and a locating peg positioned at the centre of two of the focus bushes ensures that the bulb is set into the lampholder in its correct position. Two screw terminals at the rear of the lampholder are provided for cable connections.

Shutter Assembly

6. The shutter assembly consists of a shutter barrel, shutter support arm and spring, shutter bearing rod, thrust cup and extension spring. This assembly is pivoted about the bearing rod, which is held in position in the lamp body by a retaining bush (*fig. 2*). The shutter barrel is free to travel over the lamp filament and is aligned in its axial movement by the focus plate and the carrier rods. A

push rod which engages in the thrust cup and moved by the shutter lever operates the shutter to its rear position.

7. The shutter operates against the tension of the extension spring and it is returned to its forward position when the lever is released. *Fig. 3* shows the shutter in its forward and rear positions. Two stops (*fig. 2*) provided on the lever are for adjusting the shutter barrel in its forward and rear positions.

Bulb and reflector

8. The bulb in this signalling lamp is a special type and is pre-focused. The filament is accurately set in the bulb which is located by the lampholder. This ensures correct focusing when the bulb is replaced. The reflector is made of aluminium anodised, and polished. It is secured into the housing by three retaining clips and brackets.

Cover assembly

9. The front cover assembly consists of an aluminium casting containing a front glass and gasket. A "C" spring on the inside of this cover retains the glass in position. The assembly is fitted to the body and secured by three retaining screws. Three studs on the front of the cover are for securing a filter when required.

Sights

10. The sighting arrangement is constructed from one piece of metal, and consists of two sights. The upper sight consists of a triangular front sight and a circular aperture back sight. The lower sight consists of a ring in a circular

aperture in the front sight and a circular back sight. A black rubber eyepiece is fitted to the latter back sight and protects the eye when the lamp is used in a strong wind. The sight is positioned by a raised portion on the lamp body and secured by four screws.

Electrical connections

11. The supply to the filament lamp is switched by the operation of a switch lever located in the handle. This lever shown in (fig. 2) carries a contact which is mounted on an extension arm. This arm and contact moves between two spring leaf contacts secured to an insulated block located in the handle. Connections to

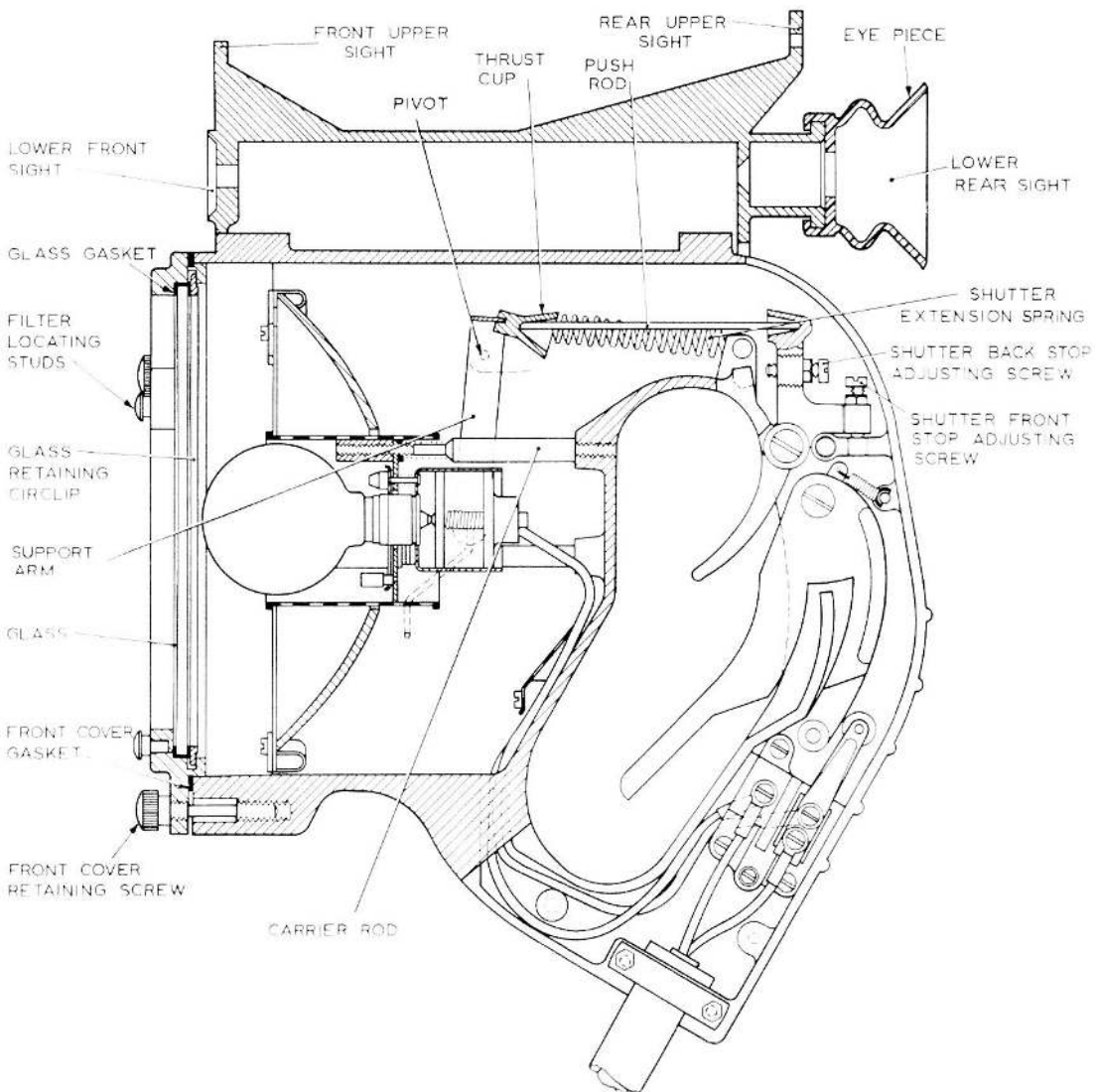

Fig. 4. Section view

RESTRICTED

the lamp and supply are provided by terminal screws on the insulated block, and connection to the filament lamp is through a hole provided between the handle and lamp body. A two-core cable together with a two-pin plug is provided for connecting the lamp to the supply. A rubber sleeve which fits over the end of the cable, protects it where it enters the handle.

SERVICING

12. The lamp should be inspected for damage and the shutter checked for free operation. In the event of damage the lamp should be tested for alignment of the beam. To do this a target at a distance of 10 ft. should be sighted and the lamp switched on. The beam should

appear approximately 4 in. below the target viewed. Failure in this test, the lamp should be returned for repair.

13. The reflector surface must be kept clean and where dirty, cleaned with a soft dry cloth, soapy water may be used. Abrasives and polish should not be used as damage to the surface will result. When replacing a filament lamp care should be taken to avoid scratching or marking the reflector.

14. The lamp should be kept free from moisture which, if present, will cause diffusion and scattering of the beam with loss of intensity. When the lamp is not in use it should be returned to its stowage box Ref. No. 5A/4411.

This file was downloaded
from the RTFM Library.

Link: www.scottbouch.com/rtfm

Please see site for usage terms,
and more aircraft documents.

