

Chapter 65

CABIN ROOF LAMP, TYPE B3550

LIST OF CONTENTS

	<i>Para</i>
<i>Introduction</i>	1
Description	2
Servicing	4
<i>Insulation resistance test</i>	5

LIST OF ILLUSTRATIONS

	<i>Fig.</i>
<i>Sectional view of lamp</i>	1

LEADING PARTICULARS

Cabin roof lamp, Type B3550	Ref. No. 5CX/5537
<i>Lamp filament, Type GE305</i>	<i>Ref. No. 5L/2648</i>
<i>Length</i> 3 $\frac{9}{16}$ in.
<i>Width</i> 2 $\frac{9}{16}$ in.
<i>Depth (face of glass to rear of reflector)</i> 1 $\frac{3}{8}$ in.

Introduction

1. The cabin roof lamp, Type B3550, is designed for flush mounting in the cabin

roof to provide general illumination in the cabin. The lamp shown in fig. 1 is normally controlled by conveniently placed remote switches.

RESTRICTED

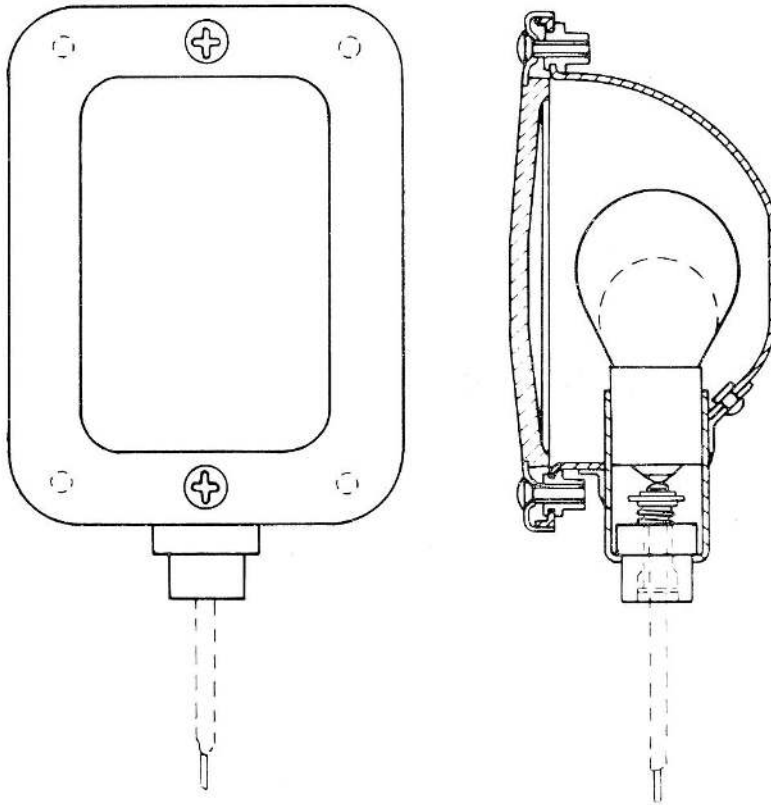

Fig. 1. Sectional view of lamp

DESCRIPTION

2. The lamp consists of a light alloy rectangular body, a lamp holder, a front glass and a front glass retaining ring. The body of the lamp which serves as a reflector incorporates the mounting flange by which it is secured to the aircraft roof. The turned rim of the body has four mounting holes, one at each corner, and also carries a threaded bush at the centre of each end to accommodate the retaining ring securing screws. The lamp holder is of the single contact, bayonet cap type and is silver soldered to a mounting bracket. It is let into the end of the lamp body and is secured by a bracket which is riveted to the lamp body.

3. The front of the lamp body is closed by a frosted glass lens, the edge of which is ground to fit the lip of the retaining ring. The retaining ring fits round the glass and is secured to the body by two screws. Connection to the lamp is made by a single conduc-

tor soldered to the contact of the lamp holder and is an integral part of the lamp.

SERVICING

4. The lamp should be examined for signs of damage and corrosion, and the lamp holder spring loaded contact examined for freedom of movement and signs of pitting and burning. The connecting wire should be checked for security of attachment and the insulation for chafing or other signs of damage. The two retaining ring securing screws must be removed to gain access for filament lamp renewal.

Insulation resistance test

5. With the filament lamp removed, using a 250V insulation resistance tester, the insulation resistance should be tested between the spring loaded contact and the lamp body. The insulation resistance should be not less than 5 megohms.

RESTRICTED

This file was downloaded
from the RTFM Library.
Link: www.scottbouch.com/rtfm

Please see site for usage terms,
and more aircraft documents.

