

ADMIRALTY  
AIR MINISTRY

## Chapter 9

### IDENTIFICATION LAMP, TYPE D

#### LIST OF CONTENTS

	Para.		Para.
Introduction	1	Operation	8
Description	2	Range	9
Installation	6	Servicing	11

#### LIST OF ILLUSTRATIONS

	Fig.
Identification lamp, Type D	1

#### LEADING PARTICULARS

		Stores Ref.
<i>Identification Lamp, Type D,</i>	<i>No. 1</i> Clear	5C/909
	<i>No. 2</i> Green	5C/912
	<i>No. 3</i> Red	5C/914
	<i>No. 4</i> Amber	5C/2729
<i>Spare fronts (with glass)</i>	Clear	5C/986
	Green	5C/987
	Red	5C/988
	Amber	5C/2730
<i>Filament lamps</i>	12V, 16W	5L/X.953201
	12V, 30W	5L/X.952401
	24V, 16W	5L/X.953202
	24V, 30W	5L/X.952404
<i>Jointing washers (langite)</i>		5C/911
<i>Weight</i>	4 oz.	
<i>Height</i>	2.83 in.	
<i>Length</i>	4.33 in.	
<i>Width</i>	2.78 in.	

RESTRICTED

ELECTRICAL MANUAL, STATIC CONSUMER EQUIPMENT (AIRBORNE)  
This is A.L. No. 37 to A.P.4343E, Vol. 1  
Section 7. List of Chapters : delete "(to be issued later)" after the title of Chapter 9, and write "(A.L.37)" in the outer margin against the deletion. Insert this Chapter 9 to follow Chapter 8, and record the incorporation of this A.L. in the Amendment Record Sheet.

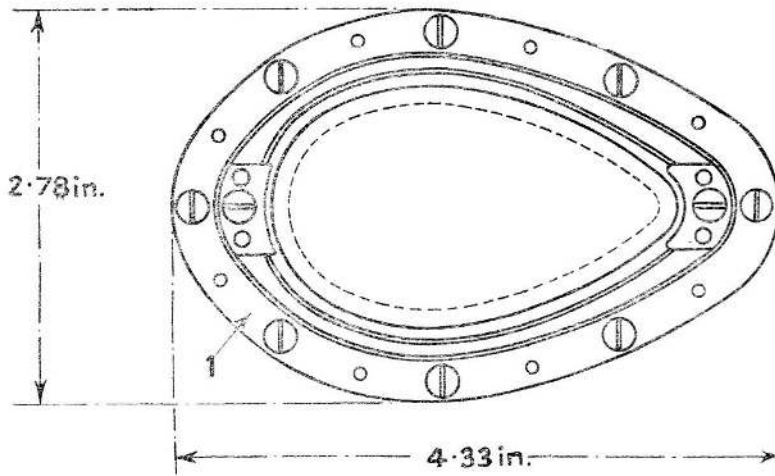
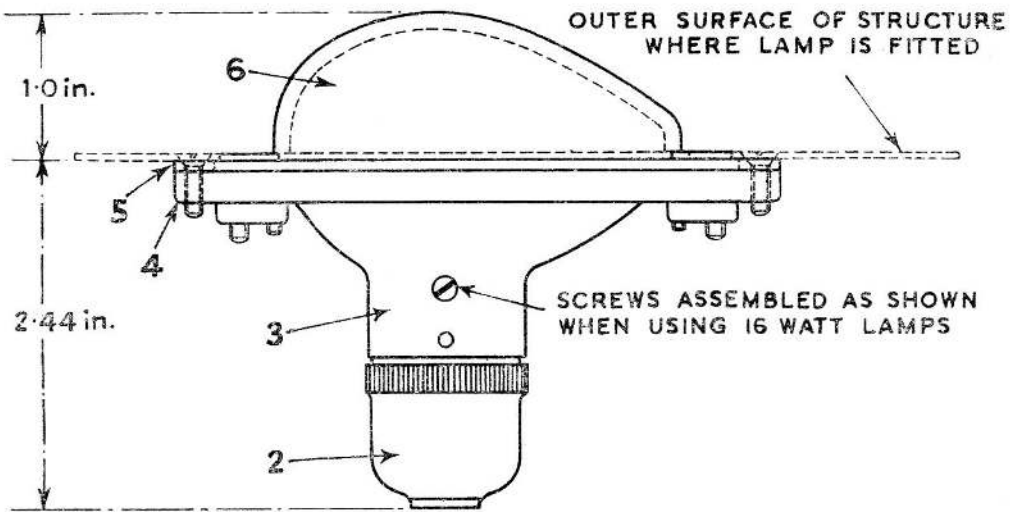

1 FIXING FLANGE  
2 LAMP SOCKET

3 REFLECTOR  
4 LAMP BODY

5 HOUSING FLANGE  
6 GLASS DOME

Fig. 1. Identification lamp, Type D

RESTRICTED

**Introduction**

1. The identification lamp, Type D, is so designed that by fitting a filament lamp of the correct wattage it is suitable for either upward or downward identification. By the use of appropriate switching the aircraft may use a steady light or signal in code. When used on small aircraft, the colour of the light may be varied by changing the glasses. On larger aircraft more than one lamp may be fitted.

**DESCRIPTION**

2. An illustration of the lamp is given in fig. 1. The lamp socket is constructed of moulded composition, is of the standard spring loaded plunger type, and is a sliding fit in the frosted aluminium reflector, to which it is secured by two 6 B.A. screws.

3. Two pairs of fixing holes are provided in the reflector to enable the holder to be fixed in alternative positions, so that a 16-watt lamp can be used for upward, or a 30-watt lamp for downward identification. As illustrated the lamp is used for upward identification. When used for downward identification, the two screws should be removed, the lamp socket moved so that the second pair of holes in the reflector register with the tapped holes in the socket, and the screws refitted.

4. The reflector is fitted to the body of the lamp and is secured at its ends by two 6 B.A. countersunk screws. The glass dome is held in an aluminium housing flange by two metal clips. The joint is made watertight and strain on the glass avoided by the use of plastic compound.

5. A glass mounting flange is fixed to the body of the lamp by two 6 B.A. countersunk screws, and a langite washer fitted between the body and the flange renders the joint watertight. The complete lamp assembly is fitted to an oval fixing flange.

**INSTALLATION**

6. When used for upward identification, the lamp can be fitted to any convenient position on the upper surface of the aircraft.

It should be as clear of obstruction as possible, and be visible from any position above the level of the aircraft.

7. The downward lamp is fixed on the lower surface of the aircraft and should also be free from obstruction. Only the glass dome projects below the surface of the airframe, the mounting flange being contained within the structure of the plane and secured with eight  $\frac{3}{32}$  in. countersunk rivets. The lamp is secured to the flange by eight 4 B.A. countersunk screws. When fitting a new lamp socket, the locating key on the socket should be removed before inserting the socket in the reflector.

**OPERATION**

8. Using an identification switchbox, the upward and downward lamps may be used to give a steady light together, or singly, or be operated together or singly by a morse key. Clear, red or green glasses may be fitted to individual lamps, or three lamps may be mounted together and so wired that they can be used individually or in any desired combination.

**Range**

9. When viewed from a point vertically below the aircraft, the range of the downward lamp is as great as is normally likely to be required, but the horizontal distance or plan range for reliable signalling is limited to about  $2\frac{1}{2}$  miles for clear glass, and is reduced when using coloured glasses.

10. The range at which signalling can be carried out with the upward lamp will depend on the angle of elevation of the observer and will be less with coloured than with clear glass. All distances will vary according to the prevailing visibility. A signalling speed in excess of eight words per minute is inadvisable when signalling in code.

**SERVICING**

11. The lamp socket connections and the correct operation of the lights should be checked periodically. Filament lamps must be renewed before they are completely burnt out. Should they show any signs of blackening they must be removed and new ones fitted.

**RESTRICTED**

This file was downloaded  
from the RTFM Library.

Link: [www.scottbouch.com/rtfm](http://www.scottbouch.com/rtfm)

Please see site for usage terms,  
and more aircraft documents.



**TELEBRIEF  
CONNECTIONS**

**E**