

Chapter 2

SEA VIXEN AUTO-THROTTLE SYSTEM

Cancelled
now 113F-0502-1

LIST OF CONTENTS

	Para.		Para.
Introduction	1	Throttle actuator	10
Throttle servo system	4	Magnetic clutch assembly	11
Unit description		Air speed datum and relay box	12
General	8	Servicing	13
Throttle actuator amplifier	9	Packaging	17

LIST OF ILLUSTRATIONS

	Fig.		Fig.
Throttle control servomechanism— schematic	1	Sea Vixen auto-throttle interconnec- tion diagram	2
		Auto-throttle signal flow	3

Introduction

1. The primary purpose of the Sea Vixen Auto-throttle system, is to regulate the air speed of the aircraft, by automatically controlling the port engine thrust via the pilot's throttle linkage. The throttle servo system maintains the air speed constant to within $\pm 1\frac{1}{2}$ knots in still air, during the final landing approach to an aircraft carrier.

2. The advantage of 'locking on' to a constant approach speed may clearly be seen if a normal 'deck' landing approach is considered, where engine thrust is manually controlled. Under these conditions the pilot must keep the aircraft speed constant at the landing datum speed. Consequently the throttle lever requires adjustment and, since the aircraft would be flying in the region of minimum drag speed, a large part of the pilot's attention, and skill would be required to maintain a constant speed approach.

3. Automatic speed control by the throttle servo system therefore releases the pilot from a difficult task, enabling

him to concentrate on the mirror and his other instruments during the landing approach. The chosen datum speed for auto-throttle engagement is dependent on the aircraft's configuration (i.e. flaps), and its landing weight. This speed is the optimum for landing characteristics, and the throttle servo system is designed to maintain the aircraft speed at this optimum figure.

Throttle servo system (fig. 1 and 3)

4. Primary control of the throttle servo system is by an air speed error signal which enables the system to correct deviations from a datum air speed. This signal is obtained by comparing a signal for an Air speed sensing unit with a preset air speed datum, this datum normally being set at 130 knots. In the Mk. 2 aircraft the pitch datum setting potentiometer offsets the airspeed datum, giving an effective air speed datum of 132 knots.

5. The system is also controlled by a pitch attitude signal which enables the throttle servo to anticipate the thrust changes required to compensate for attitude deviations which will result in speed changes.

RESTRICTED

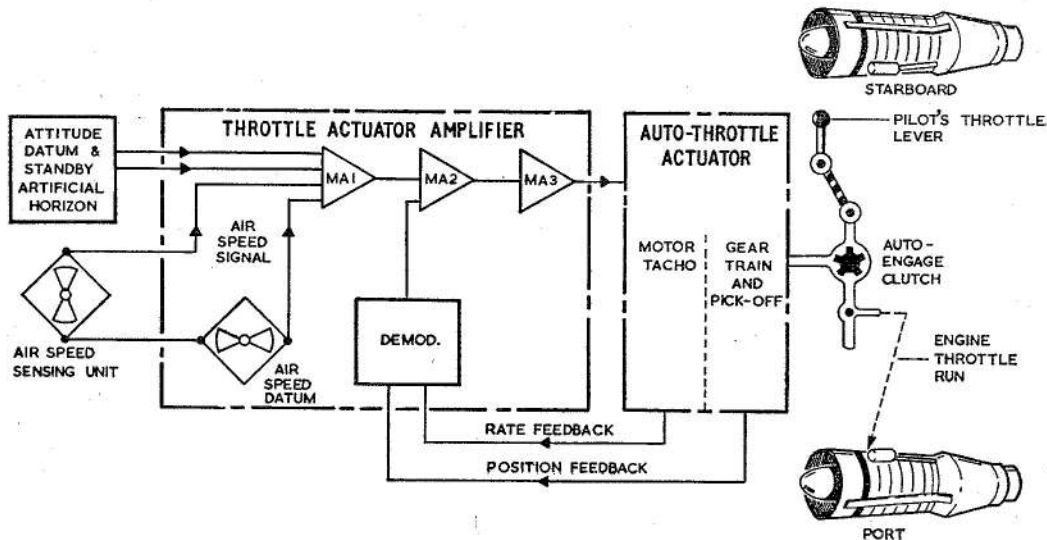

Fig. 1. Throttle control servomechanism—Schematic

This signal is obtained by comparing a pitch angle signal, sensed by a pitch signal potentiometer fitted in the standby artificial horizon, with an attitude datum. This attitude datum consists of a variable switch, and two potentiometers, the potentiometers are used for setting up the attitude datum and the variable switch marked in 1 knot divisions is used to provide speed variations of up to ± 5 knots. The zero position of the switch is equivalent to a 7.5 deg nose-up attitude, 130 knots (132 knots for Sea Vixen Mk. 2).

6. The air speed error signal, and the attitude correcting signal are applied to separate control windings of the first of the three magnetic amplifiers connected in cascade. The output from the third amplifier controls the amplitude and phase of the supply to the control winding of a motor tachogenerator within the actuator, and controls its speed, and direction of rotation. The motor drives an output ram through a reduction gear train, rack and pinion; this output is coupled through a clutch to the throttle linkage.

7. Position feedback is derived from an a.c. pick-off mechanically coupled to the output shaft, and rate feedback is derived from the tachogenerator. Both forms of feedback are algebraically summed, demodulated and applied to a common control winding on the second magnetic amplifier.

UNIT DESCRIPTION

General

8. The complete Sea Vixen Auto-throttle system (fig. 2) consists of four main units which have a total weight of 12.32 lb (excluding cable harness and piping). Brief descriptions of these units are given in the following paragraphs; full descriptions are given in other sections of this A.P.

Throttle actuator amplifier

9. The throttle actuator amplifier (Ref. No. 6TE/4449) functions in association with a throttle actuator to operate the port engine throttle, via a magnetic clutch, in response to thrust demands from signals obtained from the standby artificial horizon for pitch attitude and air speed sensing unit for air speed control. The unit is fitted in a mounting tray (Ref. No. 6TD/603).

Throttle actuator

10. The throttle actuator (Ref. No. 6TE/4453) controls the port engine throttle, to increase or decrease engine thrust as required in response to electrical signals from the throttle actuator amplifier. The output shaft of the actuator is driven via a gear train and rack by an electric motor, and has a linear motion which is coupled through a clutch to the port throttle linkage.

RESTRICTED

Magnetic clutch assembly

11. The magnetic clutch (Ref. No. 6TE/4456) couples the output of the auto-throttle actuator to the aircraft's throttle control linkage. The clutch is normally disengaged during flight. When the pilot engages the system the clutch locks the actuator to the control run, and the actuator then moves the entire throttle linkage.

Air speed datum and relay box

12. The air speed datum and relay box (Ref. No. 26FY/18964) is used in the auto-throttle system to provide an air speed signal relative to 130 knots, to the auto-throttle amplifier. It also contains relays which maintain a correct switching sequence, of the a.c. and d.c. supplies, and safety circuits for the complete system.

SERVICING

13. The 1st Line Servicing Procedures for the Sea Vixen Mk. 1 Auto-throttle Installation are given in A.P.4647A Volume 5 Flexible Servicing, Book 3.

14. The 1st Line Servicing Procedures for the Sea Vixen Mk. 2 Auto-throttle Installation are given in A.P.4647B Volume 5 Flexible Servicing Book 3.

15 Instruction for unit servicing will be found in the appropriate chapters of A.P.4343K.

16. The system test procedure involve the use of the following test equipment :—

- (1) Test set, auto-throttle 1st Line (Ref. No. 26FY/95399). Details of this test set will be found in A.P.4343K, Vol. 1, Sect. 10.
- (2) Pitot-static test set Mk. 3 (Ref. No. 6C/2106). Instructions for the use of this test set are contained in 1275T Volume 1, Section 3, Chapter 38.

PACKAGING

17. The packaging instructions for each individual unit of the auto-throttle system is included in their respective chapters.

RESTRICTED

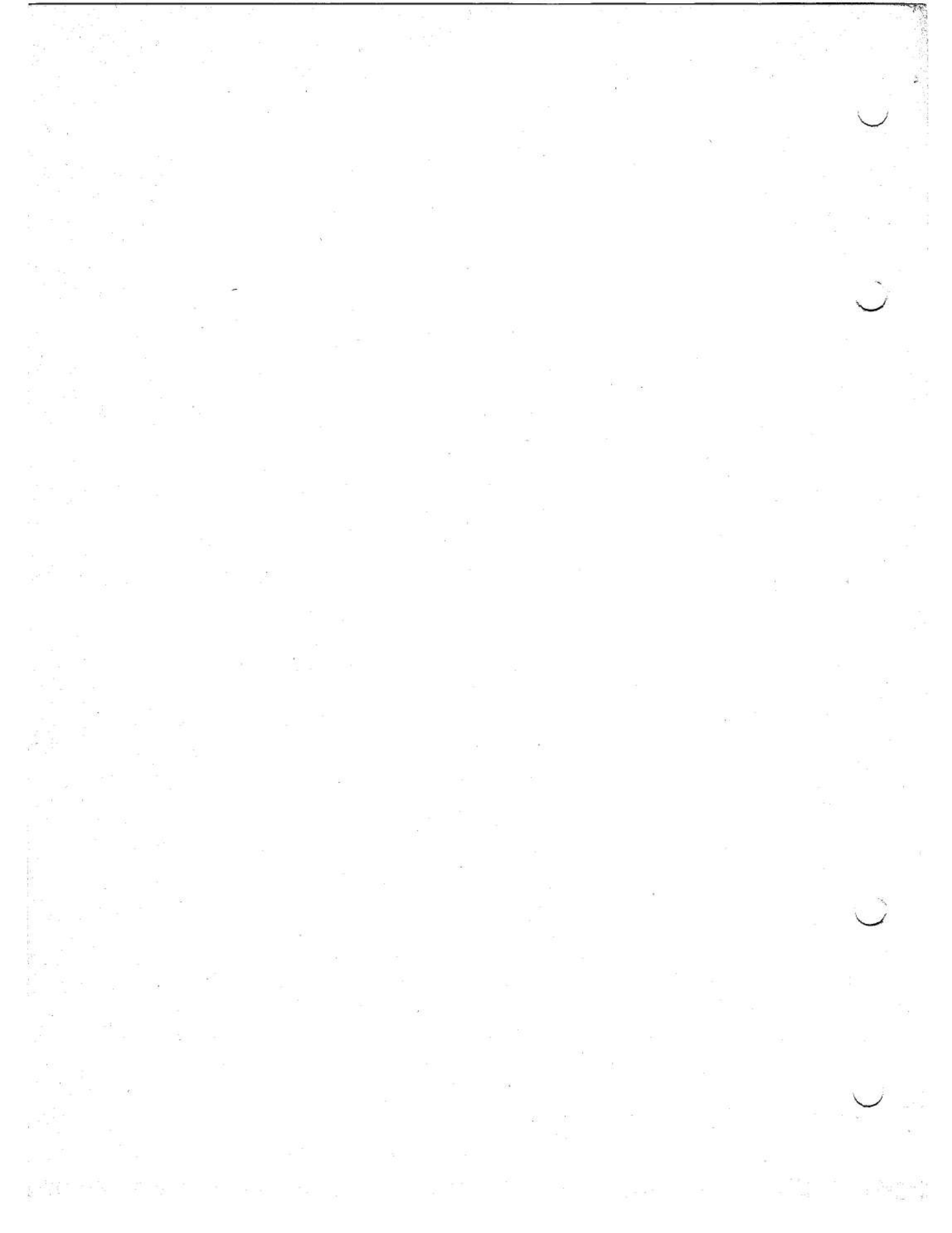

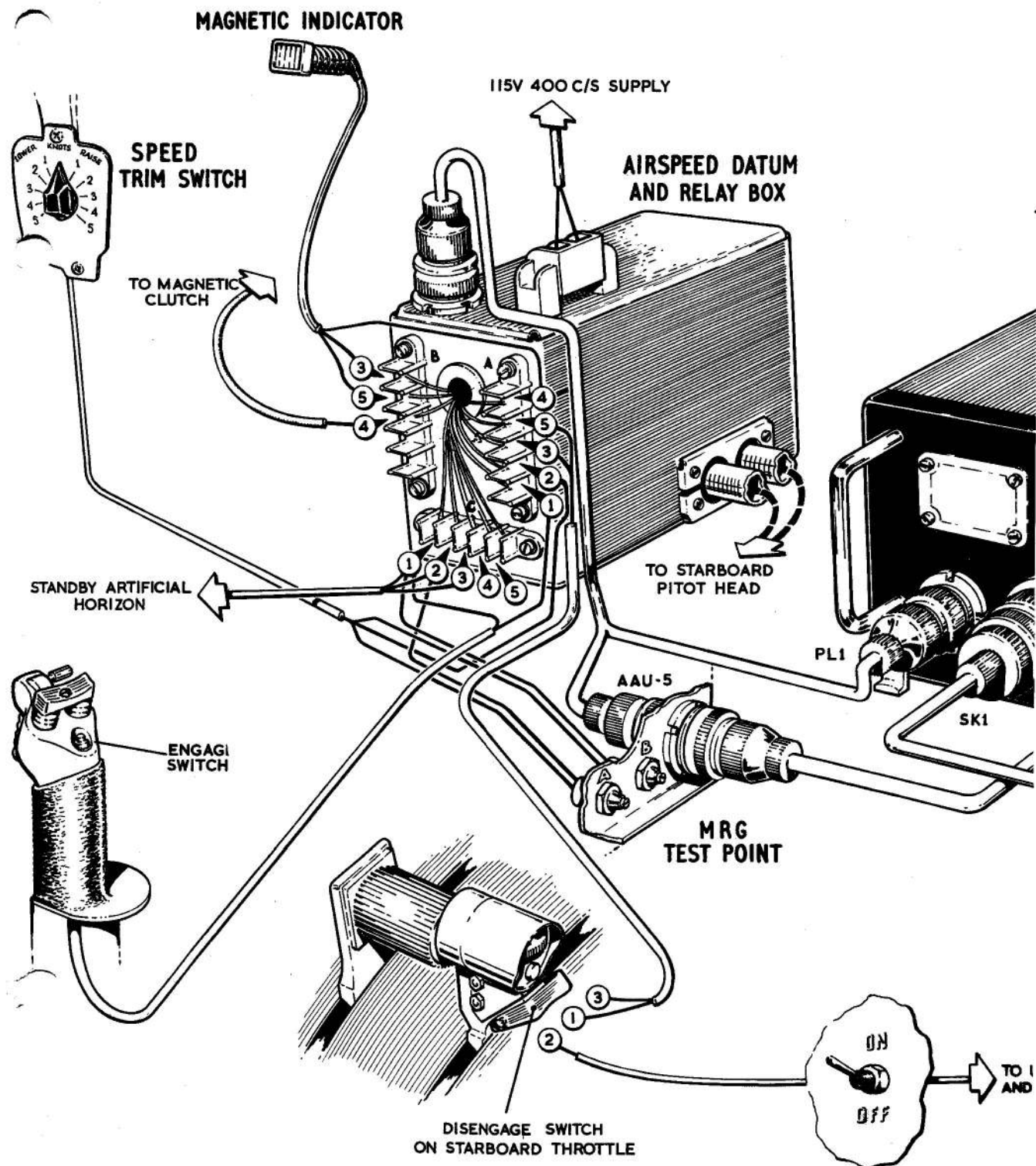

FR?

Sea Vixen auto-throttle
RESTR

**THROTTLE ACTUATOR
AMPLIFIER**

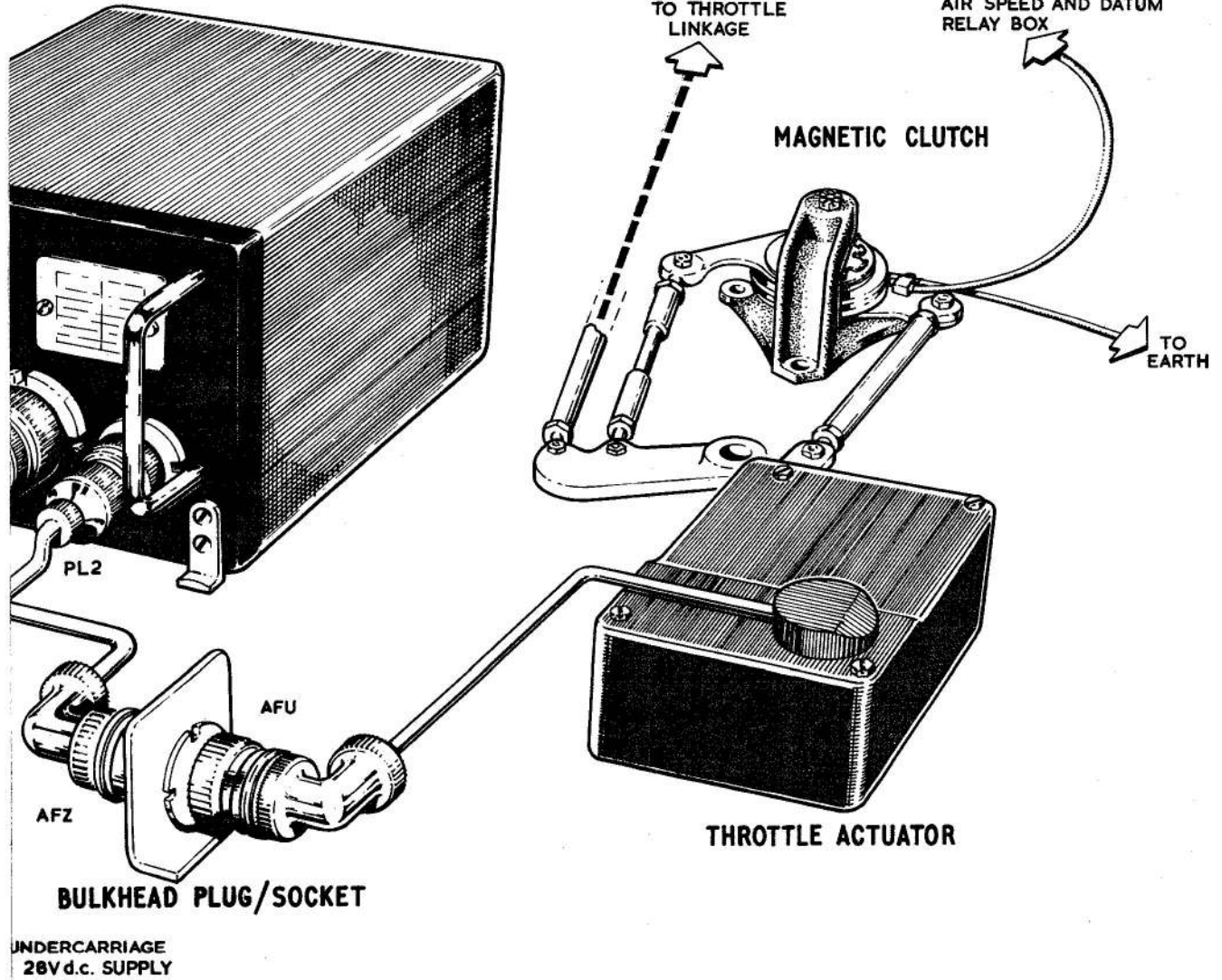

interconnections diagram
ICTED

FIG.2

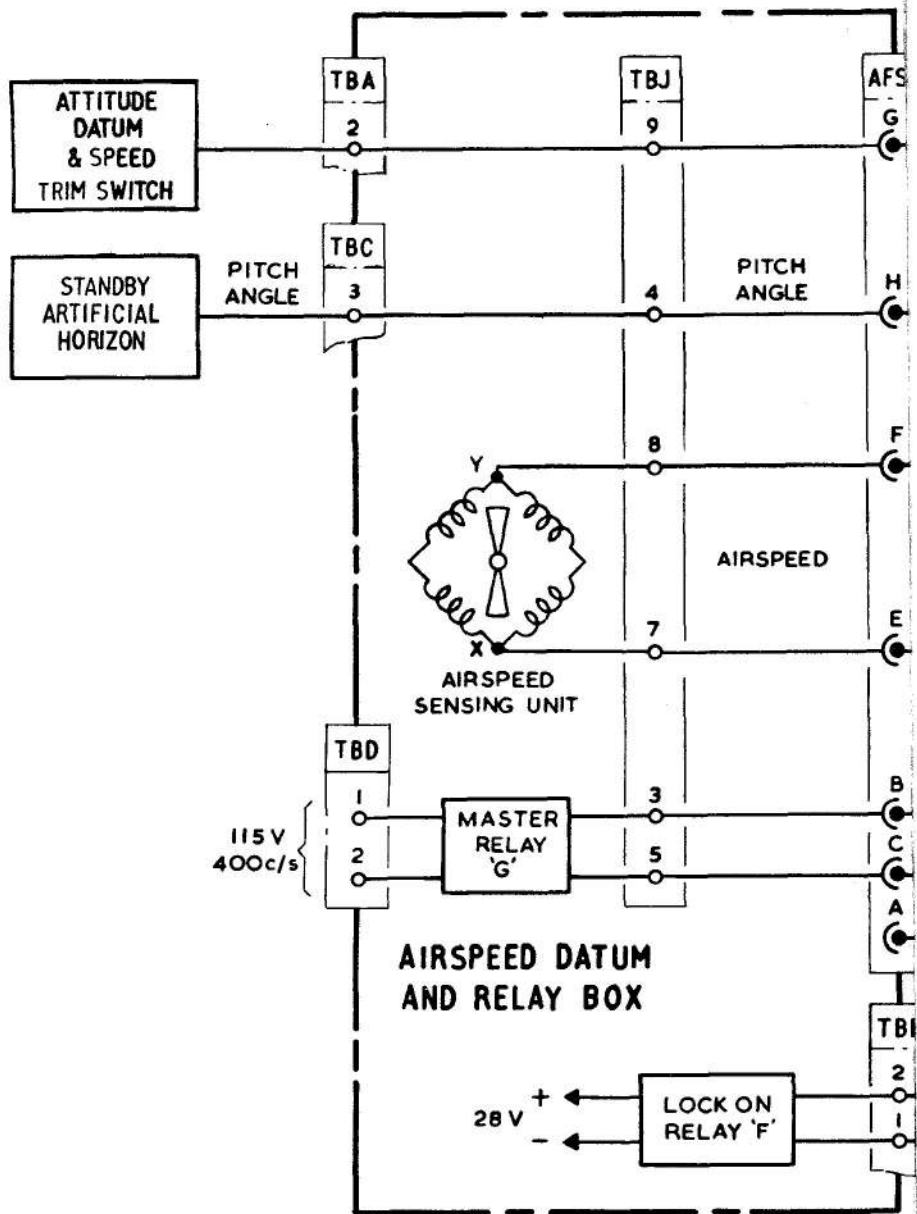
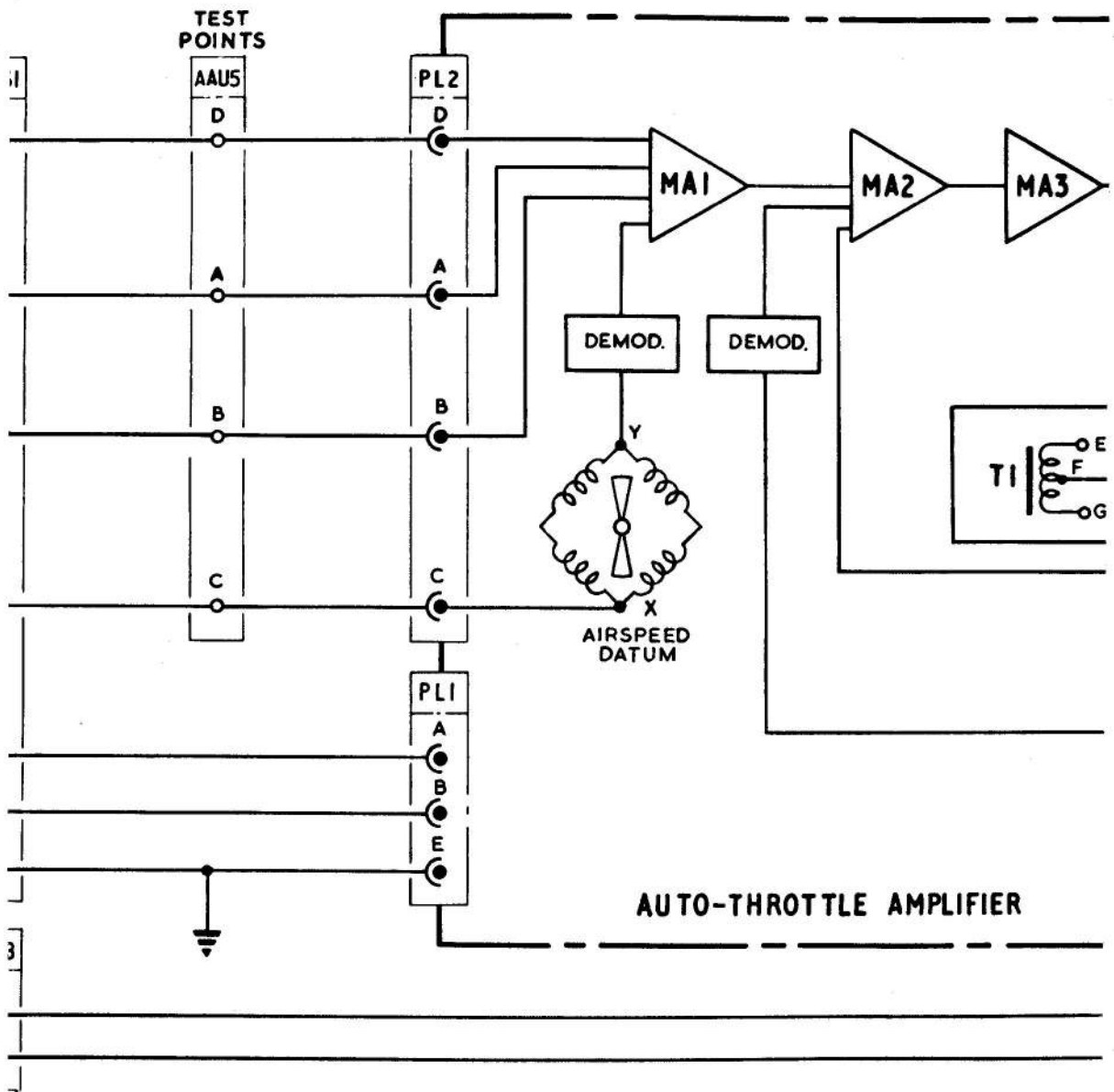

Fig.3



Auto-throttle signal flow
RESTRICTED

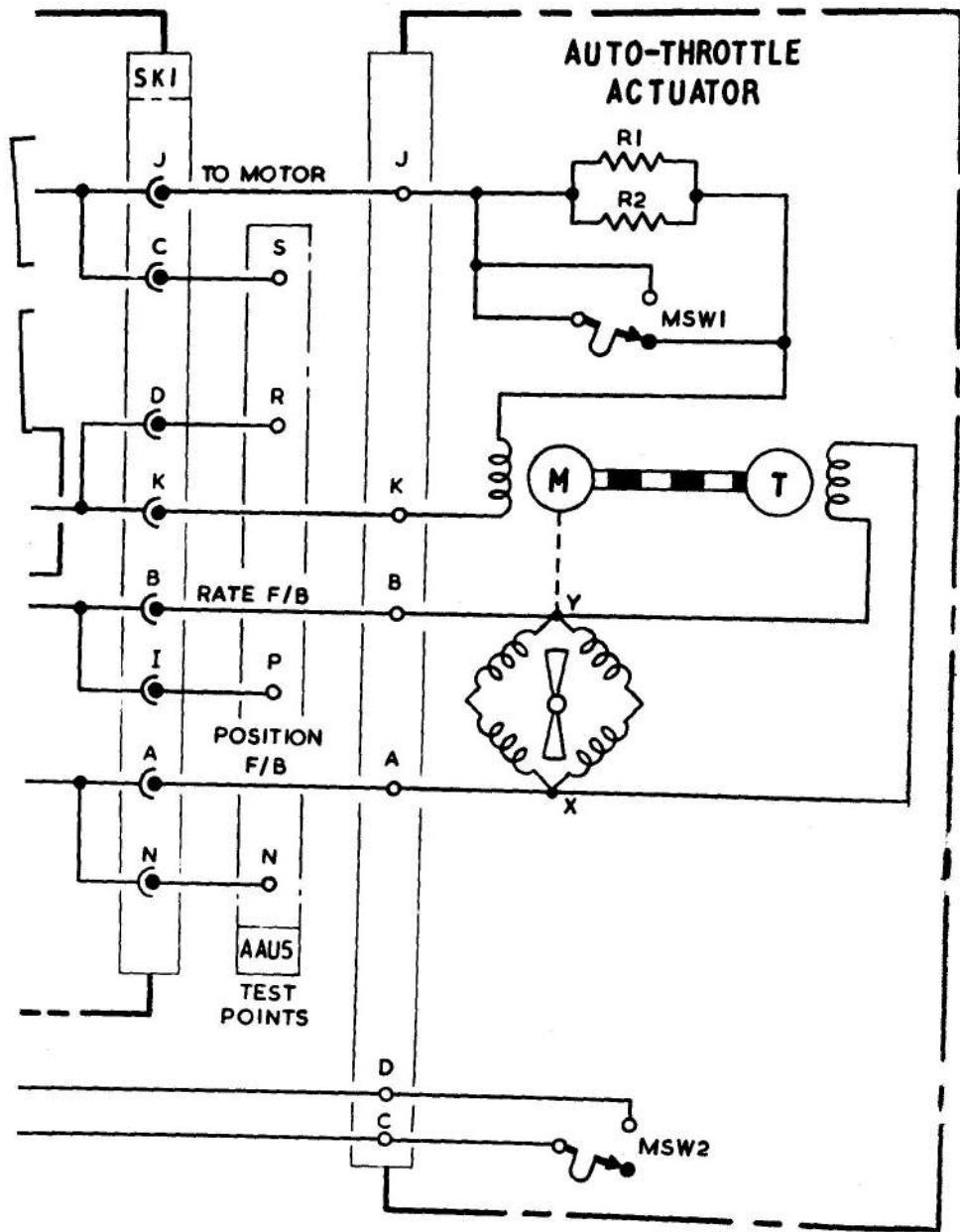

Fig. 3

1

2

3

4

This file was downloaded
from the RTFM Library.

Link: www.scottbouch.com/rtfm

Please see site for usage terms,
and more aircraft documents.

