

*Cancelled
now AP113F-0204-1*

Chapter 5

TEST SET, ULTRA, TYPE QT4066

LIST OF CONTENTS

	Para.		Para.
Introduction	1	General	21
Description	4	400 c/s oscillator	22
Meters, controls and indicators	5	Discriminator input circuit	24
Plugs and sockets	9	Governor input circuit	25
Cableform	10	Servicing	
Ancillary equipment	11	General	26
Principles of operation		Test equipment	27
General	12	Power supply	28
QT4063 control circuit	14	400 c/s oscillator checks	29
Discriminator input circuit	15	Discriminator output circuit checks	30
Governor input circuit	16	Governor input circuit checks	31
Dummy throttle motor	17	Dummy throttle motor checks	32
Override circuit	18	Test cableform checks	33
Test switches	19	Fault finding	34
Circuit description			

LIST OF TABLES

	Table		Table
Connections to SKT2 via test cableform	1	Circuit voltages	2

LIST OF ILLUSTRATIONS

	Fig.		Fig.
Test set, Ultra, Type QT4066	1	Component location diagram	5
Test equipment interconnections	2	Circuit diagram of test cableform	6
Front panel of test set, Type QT4066	3	Circuit diagram of test set, Type QT4066	7
Component location diagram	4		

LIST OF APPENDICES

		App.
Ancillary test equipment used with test set, Ultra, Type QT4066		1

LEADING PARTICULARS

Test set, Ultra, Type QT4066	Ref. No. 5G/3284
Power supplies	110 to 120V, 50 c/s or 200 to 250V, 50 c/s and 28V d.c.
Overall dimensions (excluding cableform)	36in. × 18in. × 12in.

RESTRICTED

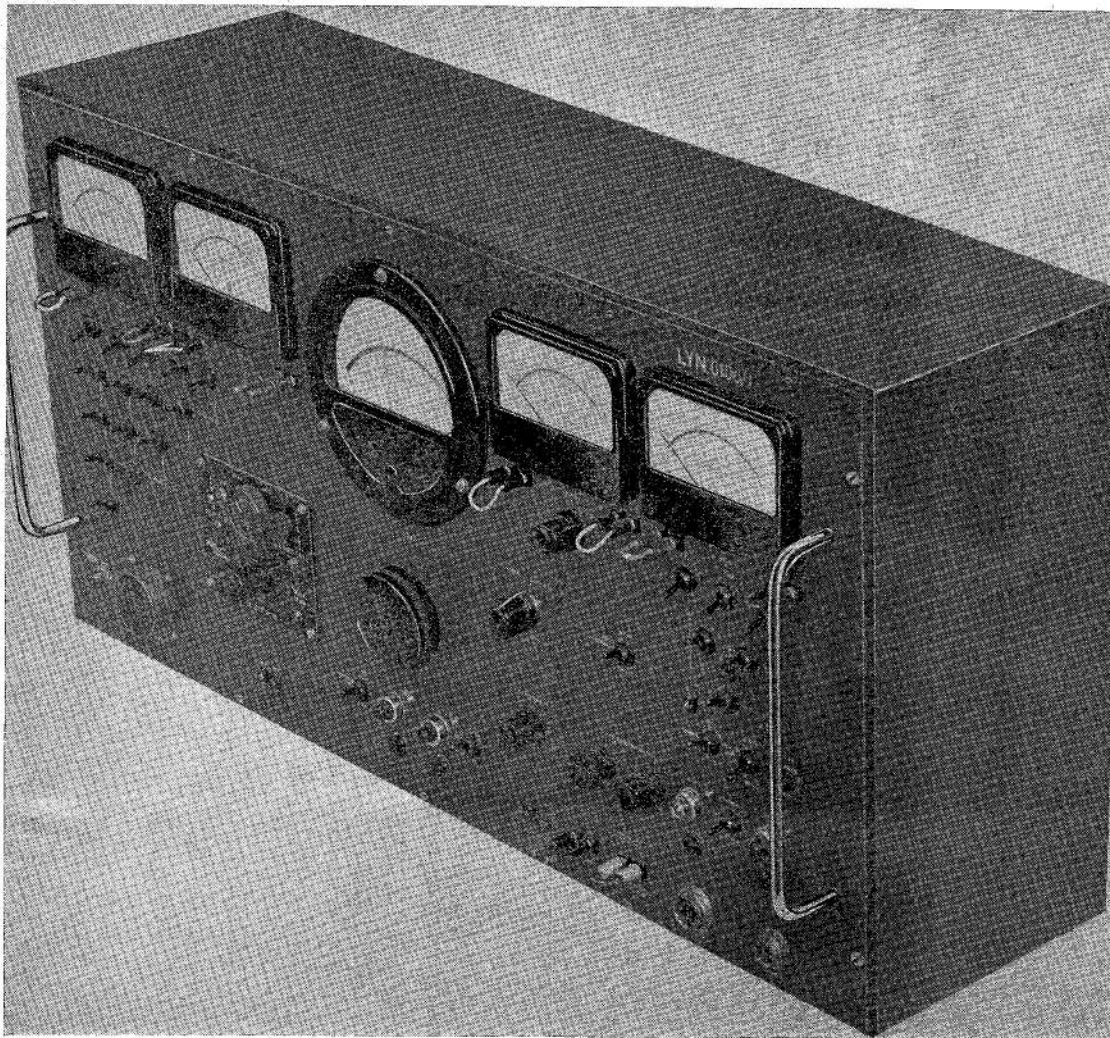

Fig. 1. Test set, Ultra, Type QT 4066

Introduction

1. Test set, Ultra, Type QT4066 is used for bench testing the components of the Throttle Control System, Ultra, Type B.A.P.3. The following units are used in conjunction with the test set:—

- (1) Test equipment, Ultra, Type Q2A8, which is described in A.P.4343K, Vol. 1, Sect. 10, Chap. 7.
- (2) Power amplifier, Ultra, Type QT 4063, which is described in A.P.4343K, Vol. 1, Sect. 10, Chap. 6.
- (3) Adaptor box, Ultra, Type QY4022.
- (4) Amplifier, Ultra, Type A401/3.
- (5) Throttle motor, Ultra, Type M174/1.
- (6) Transmitter, Ultra, Type T401/1 or T401/2.
- (7) C.J.C. unit, Ultra, Type C402.
- (8) Display unit, Ultra, Type D400.
- (9) Dummy C.J.C. unit.
- (10) Cambridge Workshop Potentiometer.
- (11) Engine speed indicator.
- (12) Galvanometer.
- (13) Multimeter, Type 12889.
- (14) Transmitter test jig, a description of which will be found in A.P.4343K, Vol. 1, Sect. 5, Chap. 1.

RESTRICTED

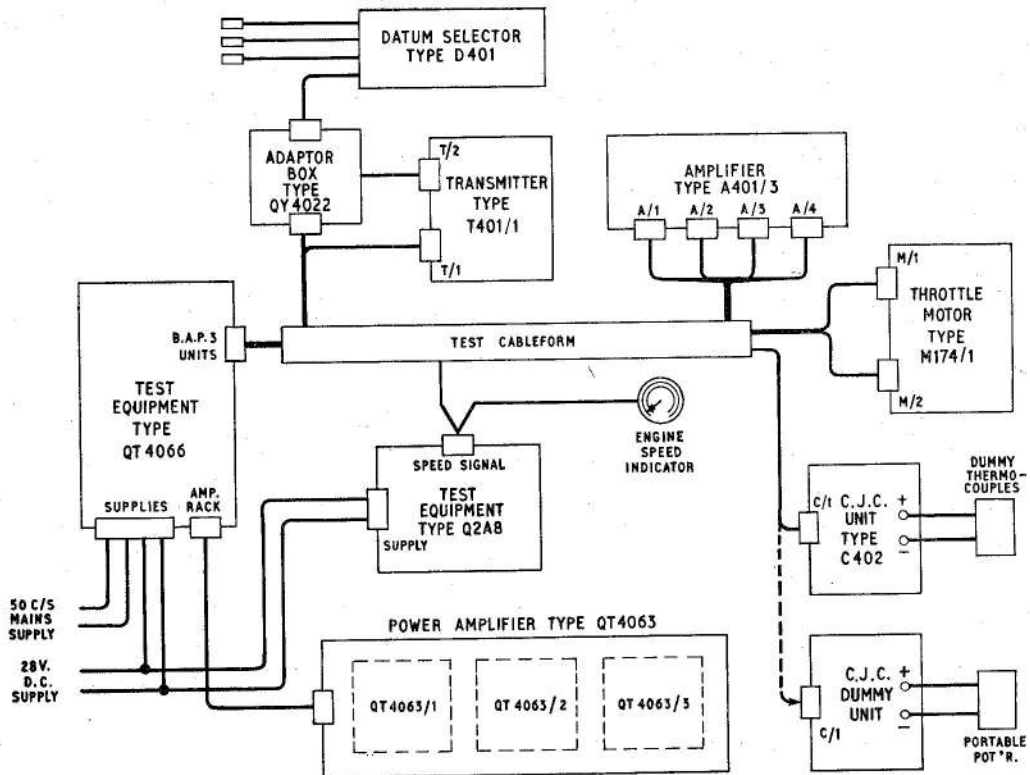

Fig. 2. Test equipment interconnections

- (15) Throttle motor test jig, a description of which will be found in A.P.4343K, Vol. 1, Sect. 7, Chap. 1.
- (16) Test cableform, which forms part of the test set, Type QT4066.
- (17) Dummy thermocouples.
- (18) Stopwatch.
2. The units are connected as shown in fig. 2. In conjunction with the units listed in para. 1, test set Type QT4066 is capable of performing standard serviceability tests on the following B.A.P.3. units:—
- (1) Amplifier, Type A401/3.
 - (2) Throttle motor, Type M174/1.
 - (3) Transmitter, Type T401/1 or T401/2.
 - (4) C.J.C. unit, Type C402.
 - (5) Datum selector, Type D401.
3. Test set, Type QT4066 comprises the following main circuits (fig. 7).
- (1) A 300 to 500 c/s oscillator feeding into the power amplifier, Type QT4063.
 - (2) A discriminator input circuit to simulate throttle demand signals.
 - (3) A governor input circuit to simulate signals from the speed governor circuit.
 - (4) A dummy normal throttle motor.
 - (5) A d.c. supply circuit to operate the override control and warning light system.
 - (6) Meter circuits to measure the voltages and currents of the 115V, 400 c/s supply from the power amplifier, Type QT4063 and the 28V d.c. supply.
 - (7) Switching circuits to test the operation of the safety systems.
 - (8) Provision is made for connecting a display unit, Type D400, to the slave transmitter. The display unit simulates one channel of the speed governor, datum selector and trim indicator circuits of the B.A.P.3. system.

RESTRICTED

DESCRIPTION

4. Test set, Type QT4066 is intended for bench or rack mounting and comprises a front panel (*fig. 3*), on which is located the controls, indicators and connecting plugs, and a chassis, on which is mounted the circuit components (*fig. 4 and 5*). An aperture is provided in the front panel to house the display unit, Type D400.

Meters, controls and indicators (*fig. 3*)

5. The following meters are provided:—

(1) Meter 1-0 to 5A d.c., used to measure the current drawn by the override motor in the throttle motor, Type M174/1.

(2) Meter 2-0 to 30V d.c., used to measure the voltage of the 28V d.c. supply to the override motor in the throttle motor, Type M174/1.

(3) Meter 3-300 to 500 c/s, used to measure the frequency of the 115V, 400 c/s supply from the power amplifier, Type QT4063.

(4) Meter 4-70 to 150V a.c., used to measure the voltage of the 115V, 400 c/s supply from the power amplifier, Type QT4063.

(5) Meter 5-0 to 1.5A a.c., used to measure the current drawn from the 115V, 400 c/s supply by the B.A.P.3 system.

6. The following controls are provided:—

(1) A slow motion drive knob, located below meter 3, controls the frequency of the 400 c/s oscillator, and hence the frequency of the 115V supply from the power amplifier, Type QT4063.

(2) SET 400 c/s—this control sets the level of the 400 c/s oscillator and hence the output supply from the power amplifier, Type QT4063.

(3) SELECT GOVERNING SIGNAL—this switch selects either the NORMAL governing signal, from the display unit, Type D400, or the SIMULATED signal from the governor input circuit in the test set.

(4) SET GOVERNOR INPUT—this control adjusts the level of the simulated governor signal.

(5) SELECT DISCRIMINATOR INPUT—this switch selects either the NORMAL discriminator signal, from the throttle motor, Type M174/1, or the SIMULATED signal from the discriminator input circuit in the test set.

(6) SET DISCRIMINATOR INPUT—these are COARSE and FINE controls and set the amplitude of the simulated discriminator signal.

(7) AMPLIFIER RACK—this switch connects a mains 50 c/s supply to the heater transformer in the power amplifier, Type QT4063.

(8) H.T.—this switch connects a further mains 50 c/s supply to the h.t. transformer in the power amplifier, Type QT4063.

(9) OVERRIDE-OFF-NORMAL—this switch selects the normal or override operating modes of the B.A.P.3 system. In the NORMAL position, the 115V, 400 c/s supply is fed to the amplifier, Type A401/3. In the OVERRIDE position, the 28V d.c. supply is fed to the override control switch in the test set and thence to the throttle motor, Type M174/1.

(10) OVERRIDE—this switch controls the d.c. supply to the throttle motor, Type M174/1. The motor is driven in an opening or closing direction depending on the setting of the switch.

(11) SELECT LOAD—this switch selects the load on the positioner output of the amplifier, Type A401/3. In the DUMMY position the amplifier output is fed to the windings of a locked motor in the test set. In the THROTTLE MOTOR position the amplifier output is fed to the throttle motor, Type M174/1.

(12) A3D PRESS TO O/C—this push-button open circuits the feedback line from the throttle motor, Type M174/1 to the amplifier Type A401/3.

(13) A cluster of six toggle switches, located below meter 5, are used to simulate short circuit and open circuit faults on the synchro system wiring, as a check on the safety circuits in the B.A.P.3 system.

(14) A cluster of fifteen toggle switches, located below meters 1 and 2 are used for short circuit and open circuit checks on the temperature system wiring.

RESTRICTED

RESTRICTED

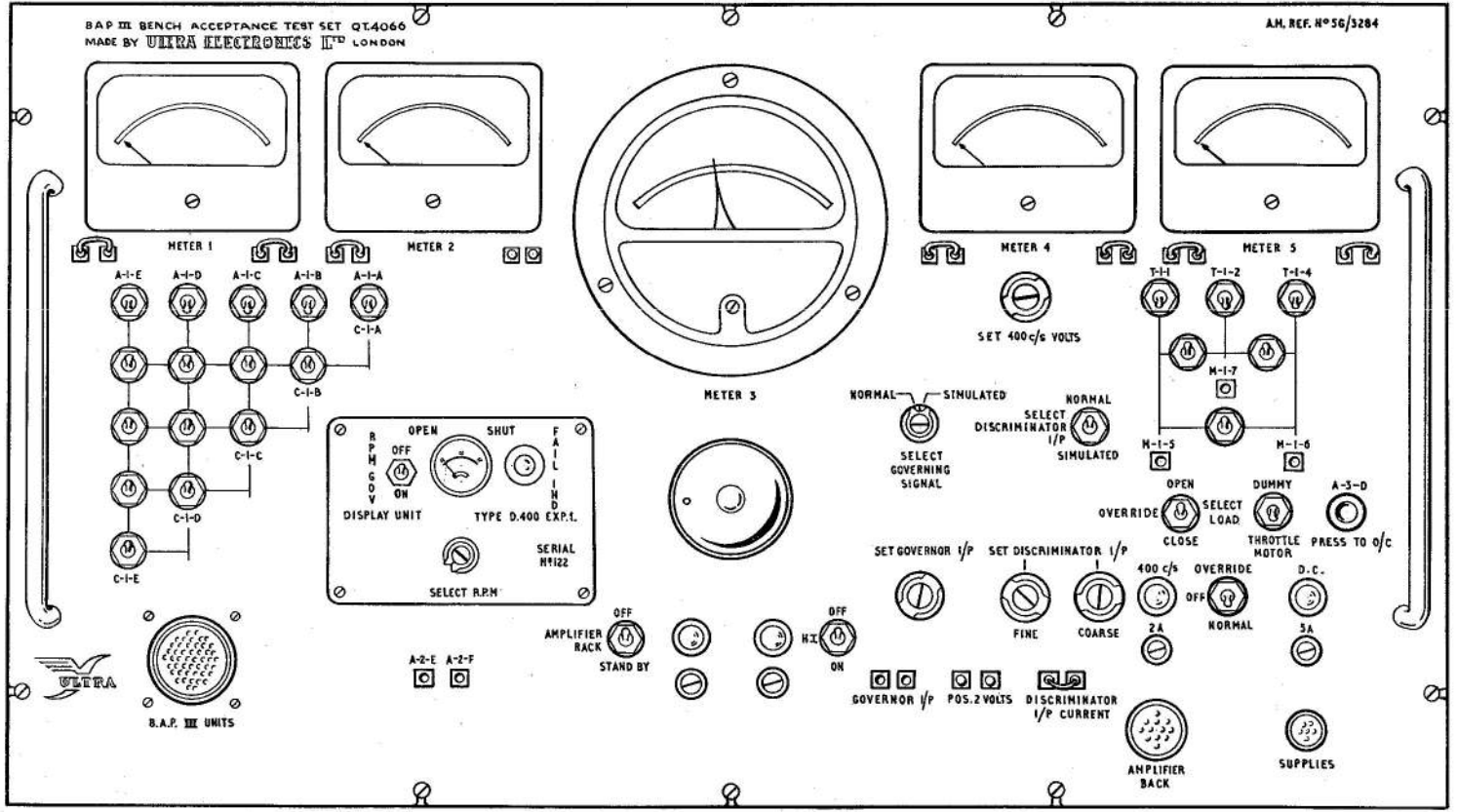

Fig. 3. Front panel of test set, Type QT4066

F.S./3

A.L.22, June 64

7. The following indicating lamps are fitted:—

- (1) Amplifier rack standby supply ON.
- (2) Amplifier rack h.t. supply ON.
- (3) 400 c/s supply to amplifier, Type A401/3 ON.
- (4) 28V d.c. supply ON.

8. Monitor points are provided to facilitate measurement of the following functions:—

- (1) Simulated governor input signal (GOVERNOR I/P).
- (2) POS. 2 VOLTS (amplifier, Type A401/3 output voltage).
- (3) Input current of simulated discriminator signal.
- (4)

M.1.5 } M.1.6 } M.1.7 }	Voltages on reset synchro stator in throttle motor, Type M174/1.
-------------------------------	--
- (5)

A.2.E. } A.2.F }	Trim indicator signal.
---------------------	------------------------

Plugs and sockets

9. The following plugs and sockets are fitted:—

- (1) SKT1—a 12-pole socket used to connect the power amplifier, Type QT 4063 to the test set. (labelled—AMPLIFIER RACK).
- (2) SKT2—a 48-pole Bendix socket used to connect the slave B.A.P.3 units, via the cableform, to the test set (labelled—B.A.P.3 UNITS).
- (3) SKT3—a 4-pole socket used to connect the display unit, Type D400 to the test set.
- (4) PL1—a 6-pole plug used to connect the 50 c/s mains supply to the test set (labelled—SUPPLIES).
- (5) PL2—a 12-pole plug used to connect the display unit, Type D400 to the test set.

Cableform (fig. 6)

10. The cableform provides a means of connecting the slave B.A.P.3 units to the test set. The connection to the test set B.A.P.3

UNITS socket is a 48-pole Bendix plug. From this plug the cableform has ten branch connections as follows:—

- (1) A 5-pole Breeze socket connecting to plug A1 on amplifier, Type A401/3.
- (2) A 14-pole Breeze socket connecting to plug A2 on amplifier, Type A401/3.
- (3) A 12-pole Breeze socket connecting to plug A3 on amplifier, Type A401/3.
- (4) A 2-pole Breeze socket connecting to plug A4 on amplifier, Type A401/3.
- (5) A 16-pole Cannon socket connecting to plug T1 on transmitter Type T401/1.
- (6) A 12-pole Cannon socket connecting to plug T2 on transmitter, Type T401/1.
- (7) A 5-pole Breeze socket connecting to plug C1 on the C.J.C. unit, Type C402.
- (8) A co-axial, Transradio plug connecting to the speed source (when used).
- (9) A 9-pole Breeze socket connecting to plug M1 on throttle motor unit, Type M174/1.
- (10) A 4-pole Breeze socket connecting to plug M2 on throttle motor unit, Type M174/1.

Ancillary equipment

11. Items (2) to (15) and (18), listed in para. 1, do not form part of the test set, Type QT 4066. They are described in Appendix 1 and are connected to the test set, and to each other, as shown in fig. 2.

PRINCIPLES OF OPERATION

General

12. As described in para. 1, the test set Type QT4066, operates in conjunction with other items of test equipment. It will be seen, in fig. 2, that the test set acts, mainly, as a junction box for the connections between the slave units of the B.A.P.3 system and the unit

RESTRICTED

which is being tested. Detailed operating instructions for the test set and the ancillary equipment will be found in the Chapters dealing with the individual components of the B.A.P.3 system. A list of these is given below:—

- (1) Amplifier, Type A401/3 in A.P. 4343K, Vol. 1, Sect. 4, Chap. 1.
- (2) Transmitter, Type T401/1 in A.P. 4343K, Vol. 1, Sect. 5, Chap. 1.
- (3) Throttle motor, Type M174/1 in A.P.4343K, Vol. 1, Sect. 7, Chap. 1.
- (4) Datum selector, Type D401/1 in A.P.4343K, Vol. 1, Sect. 6, Chap. 2.

13. The following main groups of circuits are included in the test set:—

- (1) Oscillator and mains control circuit for the power amplifier, Type QT4063.
- (2) 115V, 400 c/s monitoring circuit.
- (3) Discriminator input circuit.
- (4) Governor input circuit.
- (5) Dummy throttle motor circuit.
- (6) Override control and monitoring circuit.
- (7) Short circuit and open circuit test switches.

QT4063 control circuit

14. An oscillator in the test set generates a 400 c/s signal, the level and frequency of which can be set by two front panel controls. This signal is fed to the power amplifier where it undergoes various stages of amplification and is eventually fed back into the test set as a 115V, 400 c/s supply. The 50 c/s mains supply to the power amplifier is controlled by STANDBY and H.T. switches on the test set. The voltage, frequency and current loading of the 115V, 400 c/s supply are monitored by meters 1, 2 and 3 on the test set and fuses F2, F3 and F4 are inserted in the standby, h.t. and 115V supplies respectively. The 115V supply is fed out of the unit, via the NORMAL/OFF/OVERRIDE switch to the test cableform and thence to the slave amplifier, Type A401/3.

Discriminator input circuit

15. This circuit is used, when checking the positioner channel of the amplifier, Type A401/3, to simulate the input normally obtained from the reset synchro rotor in the throttle motor. The signal is obtained from the 115V, 400 c/s supply via a potentiometer chain giving coarse and fine adjustment of the signal. The signal is monitored at the DISC. I/P CURRENT test points on the test set and is fed, via the SELECT DISC. I/P switch and the test cableform, to the amplifier, Type A401/3.

Governor input circuit

16. This circuit is used, when checking the governor circuit of the transmitter, Type T401/1, to simulate the governor signal normally obtained from the datum selector unit, Type D401/1, or the display unit, Type D400. The signal is obtained from a 4.5V battery, via a resistor chain, and is monitored at the GOVERNOR I/P test points on the test set. The simulated signal is fed, via the SELECT GOVERNING SIGNAL switch and the test cableform, to the amplifier, Type A401/3.

Dummy throttle motor

17. The test set contains a hysteresis motor of the same type as that used in the throttle motor. The rotor is locked to simulate the normal load presented to the amplifier by the throttle motor. The dummy motor is switched into circuit by the SELECT LOAD switch and is used during positioner checks of the amplifier, Type A401/3 and for checks on the reset synchro in the throttle motor Type M174/1. Two test points labelled pos. 2 VOLTS enable the voltage applied to the windings of the dummy motor to be measured. The motor is cooled by a fan (*fig. 5*) driven from the 28V d.c. supply.

Override circuit

18. This circuit is used to check the override control system in the throttle motor, Type M174/1. It is also used during certain normal system checks when it is required to rotate the throttle motor shaft without using the slave transmitter. The override control signals are derived from an external, 28V d.c. supply. The d.c. supply is fed, via the NORMAL/OFF/OVERRIDE switch and fuse F1, to meters 1 and 2 which indicate current drawn and voltage,

RESTRICTED

respectively. The 28V d.c. supply is then fed, via the **VERRIDE** switch, to the test cableform and thence to the override motor in the throttle motor, Type M174/1. The **VERRIDE** switch feeds the d.c. supply to one or other of the override motor windings depending on the direction of throttle motor shaft movement required.

Test switches

19. A group of fifteen switches, located on the left-hand side on the test set front panel, are used to simulate short circuit and open circuit faults on the five signal lines between the C.J.C. unit, Type C402 and the amplifier, Type A401/3. These switches enable the operation of the temperature safety circuit, in the amplifier, to be checked.

20. A further group of switches, located on the right-hand side of the front panel, are used to simulate short circuit and open circuit faults on the three lines between the transmitter, Type T401/1 and the reset synchro stator in the throttle motor, Type M174/1. These switches enable the operation of the positioner safety circuit, in the transmitter, to be checked.

CIRCUIT DESCRIPTION

General

21. As will be seen from the circuit diagram, fig. 7, the test set is, mainly, in the nature of a junction box. The circuit description is, therefore, limited to the 400 c/s oscillator, the discriminator input circuit and the governor, input circuit. Table 1 lists the destinations or origins of the connections to the test set at the 48-way socket, SKT2.

400 c/s oscillator

22. V1 (a) and (b) comprise a Wien bridge oscillator in which the frequency determining component are R12, C7, C8, C9, C10 and R13. Variable capacitors C7 and C8 are ganged and provide a continuously variable frequency range of 300 c/s to 500 c/s. To maintain the output amplitude constant throughout the frequency range a thermistor, Th1, is connected, in series with C5, across the anode load of V1(b). Potentiometer RV4 controls the degree of positive feedback

applied to V1(b) and, in its optimum position, ensures an output waveform of sinusoidal shape.

23. The output of V1(b) is fed to V2(b) via C13 and thence to V2(a) via C4. The output from the anode of V2(a), is developed across RV5 and R23, connected to the cathode of V2(b). V2(a) and (b) provide a high impedance output in order to avoid frequency shift due to changes in external loads. RV6 is normally set to give an output from the power amplifier, Type QT4063 of 115V. The h.t. and heater supplies for V1 and V2 are obtained from the power amplifier.

Discriminator input circuit

24. Transformer T1 is fed with 115V, 400 c/s from the power amplifier, Type QT4063. The output of its secondary winding is fed to the resistor chain comprising R6, R7, RV2 (SET DISCRIMINATOR I/P—FINE) and RV3 (SET DISCRIMINATOR I/P—COARSE). The outputs from the sliders of RV2 and RV3 are fed to the SELECT DISC I/P switch. When this switch is in the SIMULATED position, the discriminator input signal is fed, via the test cableform, to the positioner input of the amplifier, Type A401/3. The signal line from the wiper of RV2 is broken at the DISCRIMINATOR I/P CURRENT test points to enable the input current to be measured with an external meter. Normally, these test points are shorted by a link.

Governor input circuit

25. The signals from the datum selector unit, Type D401, are in the form of two d.c. currents which are of equal value when the engine speed is at datum. The governor input circuit simulates these currents by means of a resistor chain R1, R2 and RV1 and the 4.5V battery BY1. When the slider of RV1 (SET GOVERNOR I/P) is at the centre of its travel, the currents flowing through R1 and R2 are equal. When the slider is offset, however, the currents are no longer equal and the governor amplifier in the transmitter, Type T401/1 receives an out of balance input signal corresponding to an engine speed above or below datum, depending on the setting of RV1. The difference between the two currents can be measured by connecting an ammeter between the GOVERNOR I/P test points on the front panel. Normally, these test points are shorted by a link.

RESTRICTED

TABLE 1

Connections to SKT2 via test cableform (fig. 6)

SKT2 Pole	Function	To	SKT2 Pole	Function	To
A B	{ temperature input }	A.1.A A.1.B	a b	{ not used }	T.2.11 T.2.12
C D	{ C.J.C. ref. volts from A401/3 }	A.1.C A.1.D	c d	{ not used }	A.2.E T.1.5
E	o/p of datum lift amp.	A.1.E	e f	{ temp. signal from C.J.C. }	C.1.A C.1.B
F G H	{ o/p of positioner amp. }	A.3.A A.3.B A.3.C	g h	{ C.J.C. ref. volts }	C.1.C C.1.D
J K L	{ transmitter synchro stator (via. A401/3) }	A.3.E A.3.F A.3.G	j	o/p of datum lift amp.	C.1.E
M N	{ i/p to positioner amp. }	A.3.H A.3.J	k m n	{ override control sup- plies to M174/1 }	M.2.A M.2.B M.2.C
O P	{ 115V, 400 c/s }	A.4.A A.4.B	p q r	{ normal motor control signals }	M.1.1 M.1.2 M.1.3
Q R	{ o/p of safety circuits }	T.2.1 T.2.2	s t u	{ supply volts to reset synchro }	M.1.5 M.1.6 M.1.7
S T	{ o/p to trim indicator }	T.2.3 T.2.4	v w	{ o/p signal from reset synchro }	M.1.8 M.1.9
U V	{ speed datum signal to governor amp. }	T.2.5 T.2.6	x	feedback sig. to A401/3	A.3.D
W X	{ speed signal to governor amp. }	T.2.7 T.2.8	y	o/p from feedback gen.	M.1.4
Y Z	{ engine tacho signal to datum selector }	T.2.9 T.2.10	z	not used	

Key to Table 1:—

- A — Amplifier, Type A401/3
- C — C.J.C. Unit, Type C402
- M — Throttle Motor, Type M174/1
- T — Transmitter, Type T401/1

RESTRICTED

SERVICING

General

26. Remove the test set, Type QT4066, from its rack. Reference to the circuit diagram, fig. 7, will show that a considerable amount of testing can be accomplished by simple point-to-point continuity checks. The meters may be checked by comparison with a previously calibrated Multimeter, Type 12889. Links on the front panel of the test set give access to the meter terminations for this purpose. Reference to fig. 4 and 5, illustrating the locations of the components, will facilitate point-to-point checks.

Test equipment

27. The following test equipment is required:—

- (1) Multimeter, Type 12889
- (2) Power amplifier Type QT4063
- (3) Oscilloscope capable of displaying a 400 c/s sinusoidal waveform
- (4) 2·21 kilohm \pm 10%, 1/4W resistor.
- (5) 100 ohm \pm 10%, 1/4W resistor. (two off)

Power supply

28. A 110 to 120V, 50 c/s or 200 to 250V, 50 c/s power supply is required.

400 c/s oscillator checks

29. (1) Check that the voltage selectors on the power amplifier, Type QT4063 are set for the mains supply to be used.
- (2) Connect the test set AMPLIFIER RACK connector to the power amplifier using the normal cable.
- (3) Connect the mains supply to poles A and B of the SUPPLIES connector on the test set.
- (4) Set the amplifier rack switch to STANDBY and, two minutes later, set H.T. switch to ON, and allow a three minute warm up time.
- (5) Check that the frequency control provides a range of frequency of 300 c/s to 500 c/s, as indicated on Meter 3.
- (6) Check that the SET VOLTS control provides a range of voltage of 70V to 150V.

(7) Set the oscilloscope attenuator to measure an a.c. voltage of 115V and connect the oscilloscope between the U-links below Meter 4.

(8) Set the frequency control, on the test set, to give an indicated frequency of 400 c/s on Meter 3.

(9) Using the oscilloscope timebase, measure the output frequency. This must be 400 c/s \pm 10 c/s.

(10) Observe the shape of the output waveform. This must be approximately sinusoidal.

Note . . .

If a double beam oscilloscope is used, the 400 c/s waveform may be compared with the waveform of the 50 c/s mains supply.

(11) Optimum shape of the 400 c/s waveform may be obtained by adjustment of RV5 (fig. 5).

Discriminator input circuit checks

30. (1) Connect the power amplifier and mains supply to the test set as described in para. 29(1) to 29(4).
- (2) Set the frequency to 400 c/s and the voltage to 115V.
- (3) Connect the 2·2 kilohm resistor between poles M and N of the B.A.P.3 UNITS socket.
- (4) Set the SELECT DISC. I/P switch to SIMULATED.
- (5) Remove the link between the DISC. I/P CURRENT test points and connect the Multimeter, on the 10 mA a.c. range, between the two test points.
- (6) Rotate the SET DISCRIMINATOR I/P, COARSE and FINE controls to their mid-positions, and check that the reading on the Multimeter varies by at least 2·5 mA when the COARSE control is rotated clockwise then counterclockwise.
- (7) Check that rotation of the COARSE and FINE controls results in a smooth change of current.
- (8) Switch off the mains supply and remove the test equipment and resistor. Replace the link between the DISC. I/P CURRENT test points.

RESTRICTED

RESTRICTED

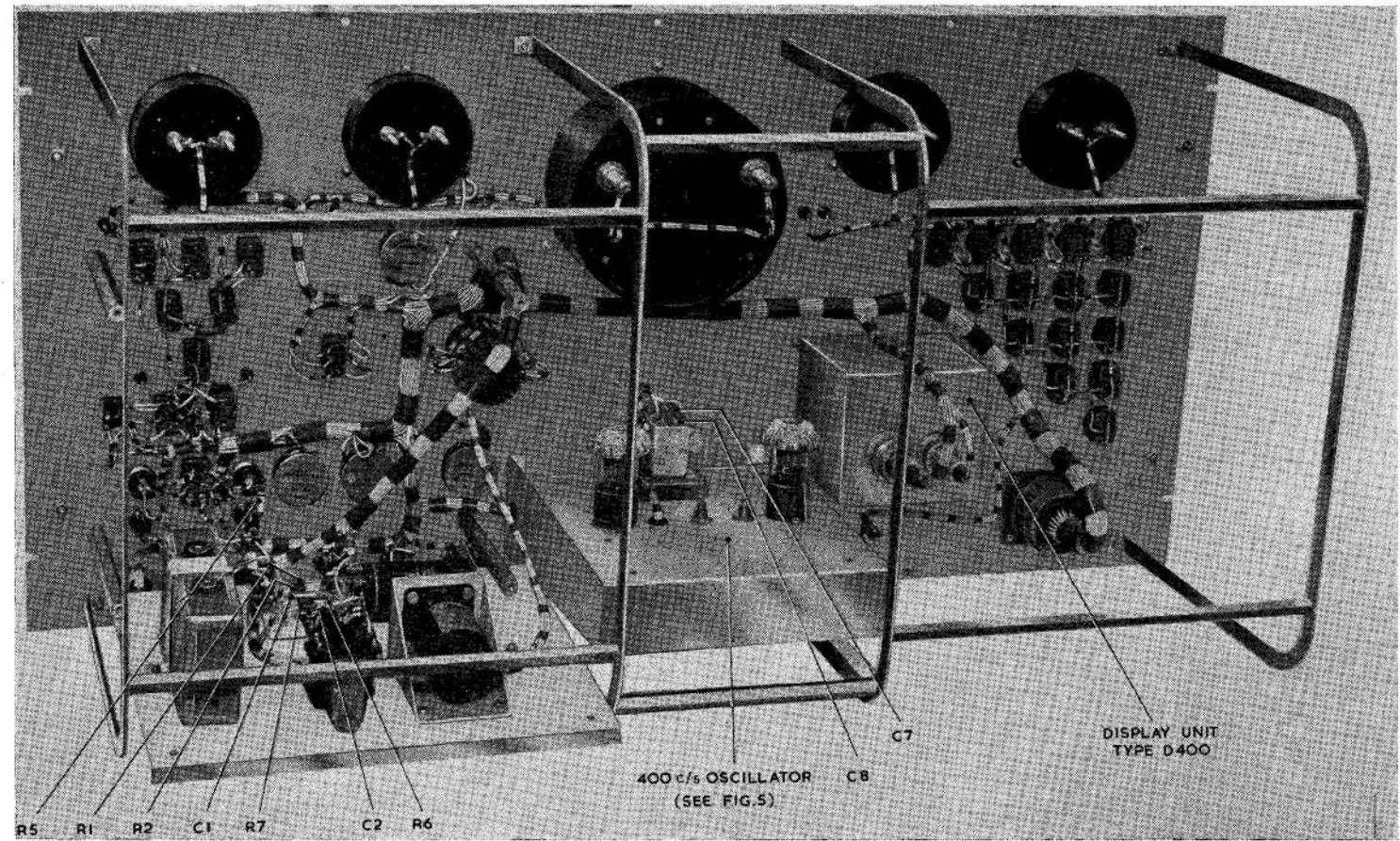

Fig. 4. Component location diagram

RESTRICTED

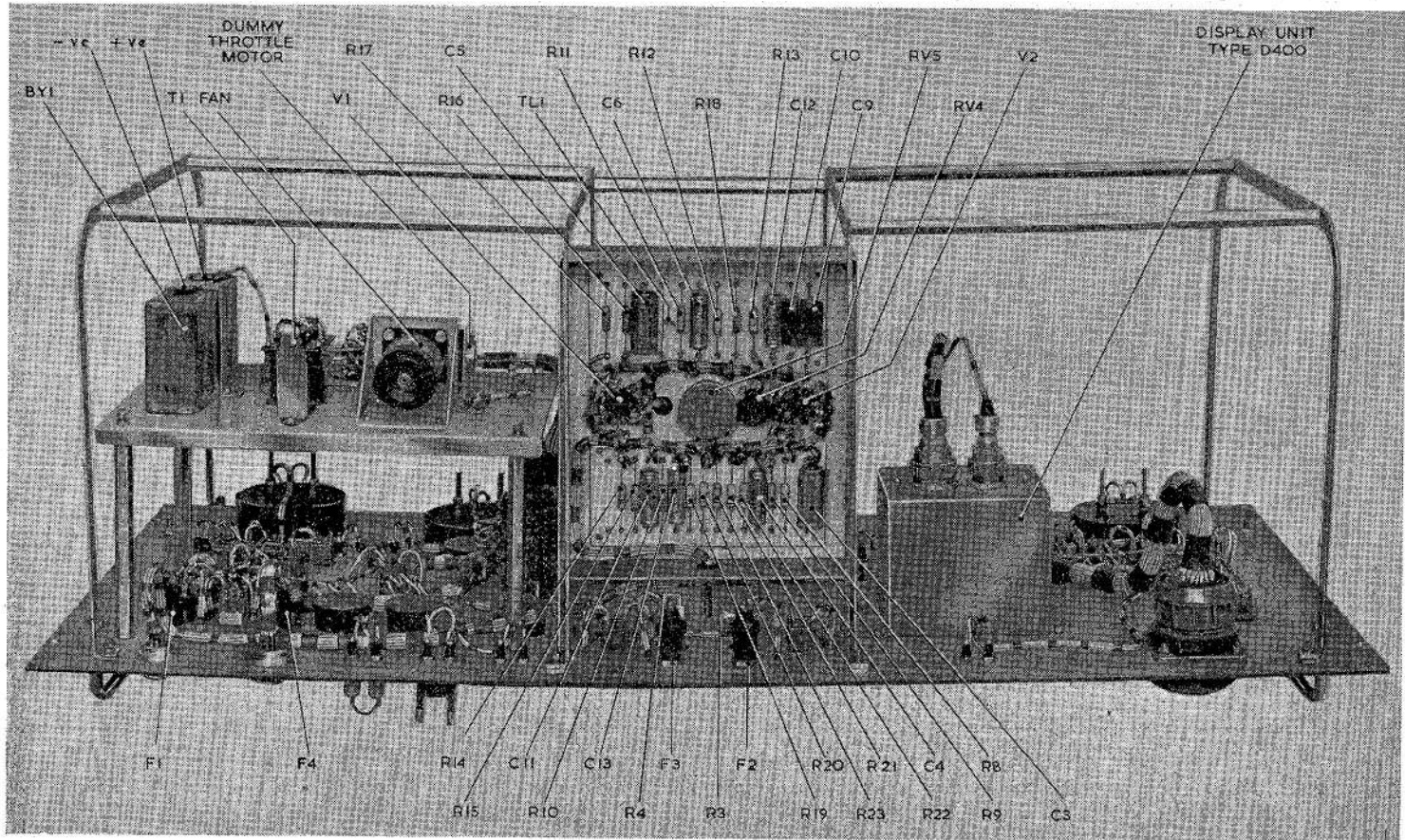

Fig. 5. Component location diagram

Governor input circuit checks

31. (1) Rotate the SET GOVERNOR I/P control fully counter clockwise.
- (2) Connect the Multimeter on the 50 μ A d.c. range, in place of the link between the GOVERNOR I/P test points.
- (3) Connect the two 100 ohm resistors between poles U-V and W-X of the B.A.P.3. UNITS socket.
- (4) Set the SELECT GOVERNING SIGNAL switch to SIMULATED and check that the reading on the Multimeter is at least 35 μ A.
- (5) Rotate the SET GOVERNOR I/P control fully clockwise and check that the reading on the Multimeter is 35 μ A.

Note . . .

It will be necessary to depress the REV M/C button on the Multimeter in order to obtain a reading.

- (6) Set the SELECT GOVERNING SIGNAL switch to NORMAL and remove the Multimeter and resistors. Replace the link between the GOVERNOR I/P test points.

Dummy throttle motor checks

32. (1) Set the SELECT LOAD switch to DUMMY.
- (2) Connect the multimeter, on the $\Omega \div 100$ range between poles F and G of the B.A.P.3 UNITS socket. The reading on the Multimeter should be within the limits 30 Ω to 37 Ω .
- (3) Transfer the Multimeter to poles G and H of the B.A.P.3 UNITS socket. The reading on the Multimeter should be within the limits 26 Ω to 35 Ω .

Test cableform checks

33. Tests on the cableform are restricted to point-to-point wiring checks. The circuit diagram, fig. 6, should be referred to when carrying out these checks.

FAULT FINDING

34. Fault finding on the 400 c/s oscillator will be facilitated by checking the circuit voltages listed in Table 2 using the Multimeter, Type 12889. The voltages shown were obtained on a unit with the test set, Type QT4066, connected to the power amplifier, Type QT4063, but with the B.A.P.3 UNITS plug disconnected.

TABLE 2**Circuit Voltages**

Monitor points	Multimeter range	Reading
V1, pin 2 to chassis	100V d.c.	86V
V1, pin 3 to chassis	10V d.c.	2.3V
V1, pin 5 to chassis	100V d.c.	88V
V1, pin 6 to chassis	10V d.c.	9.2V
V2, pin 2 to chassis	100V d.c.	50V
V2, pin 3 to chassis	2.5V d.c.	0V
V2, pin 5 to chassis	250V d.c.	109V
V2, pin 6 to chassis	10V d.c.	4.4V

35. It will be noticed that no limits have been quoted on the voltage readings. These figures are merely intended as a general

guide and will depend on the settings of RV4, RV5 and RV6.

RESTRICTED

○

○

○

○

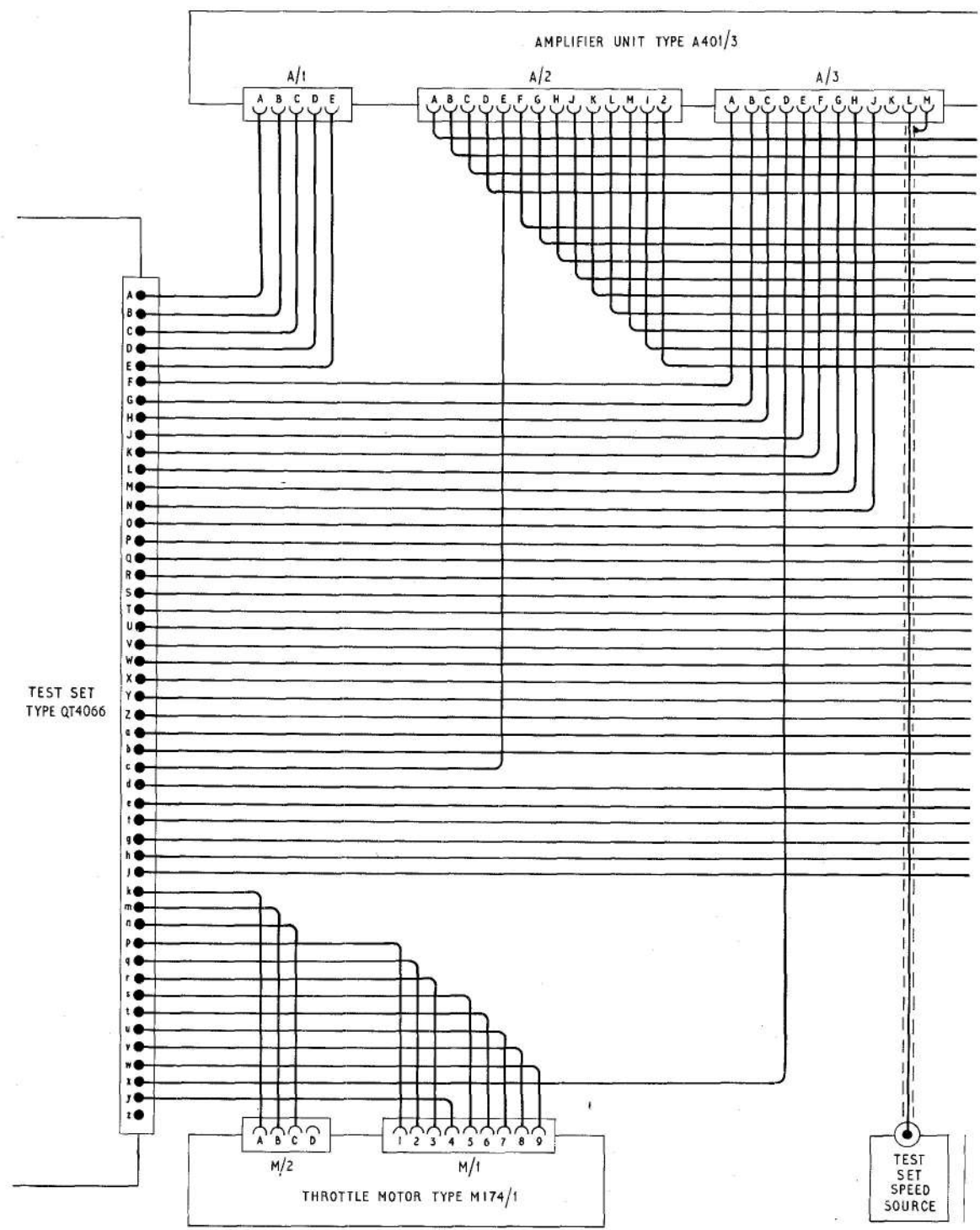

Fig.6
G.C.M.-372588 - 22-7-64

Circuit diagram of test cableform
RESTRICTED

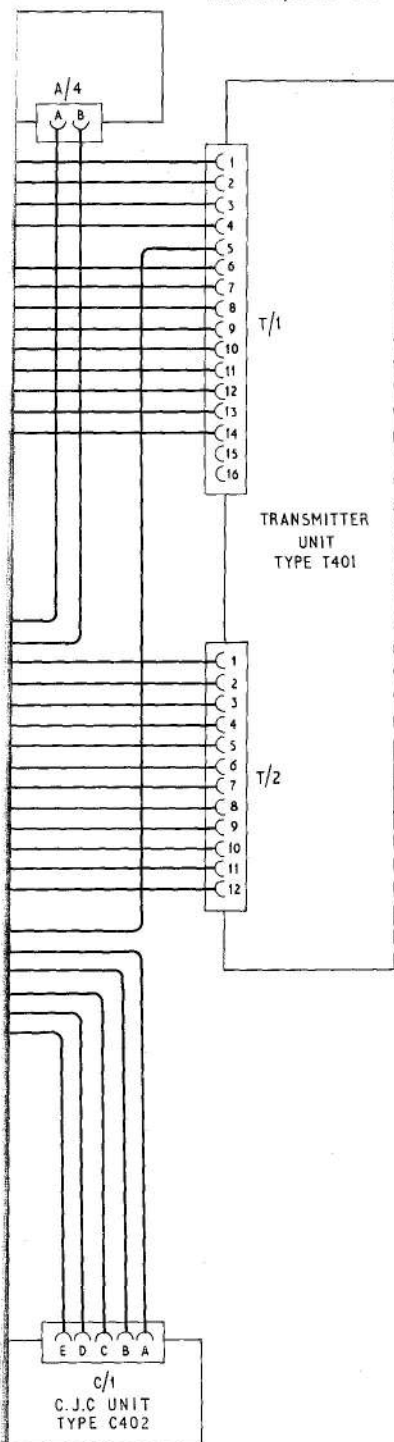
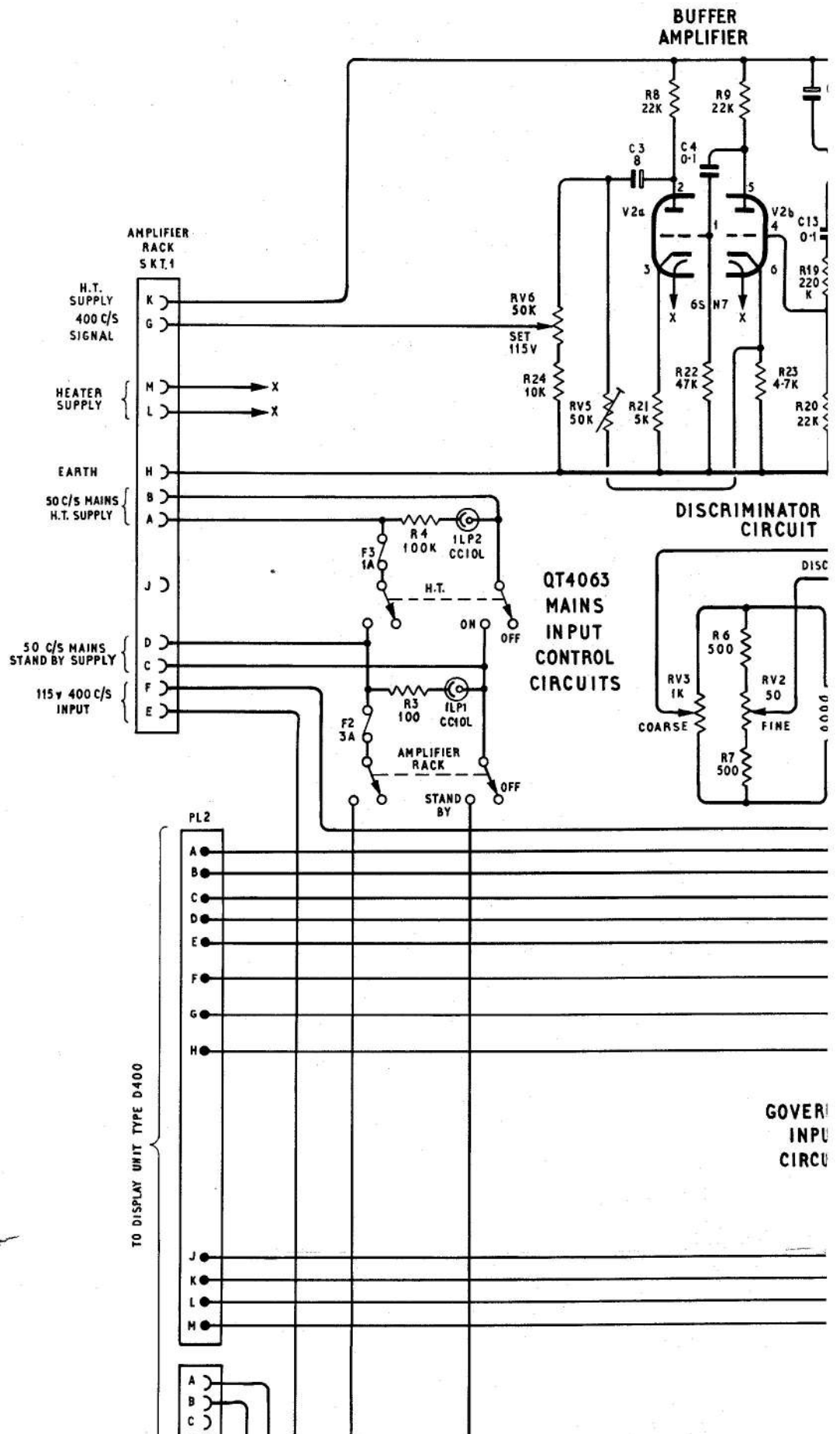
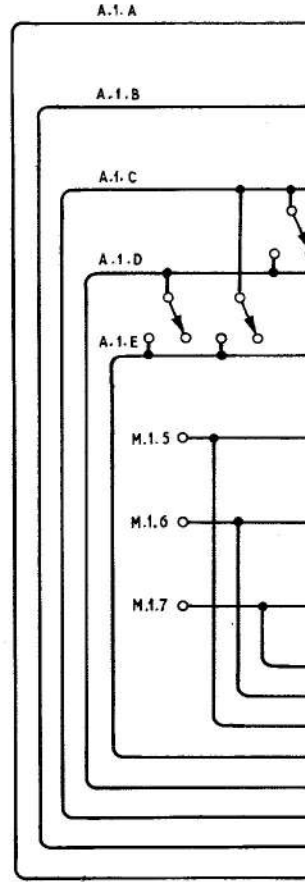
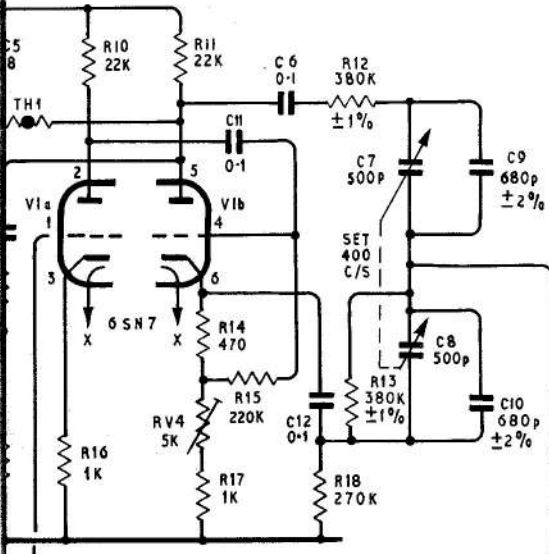

Fig.6



400c/s
OSCILLATOR

SA



INPUT 400c/s SUPPLY MONITORING
CIRCUIT

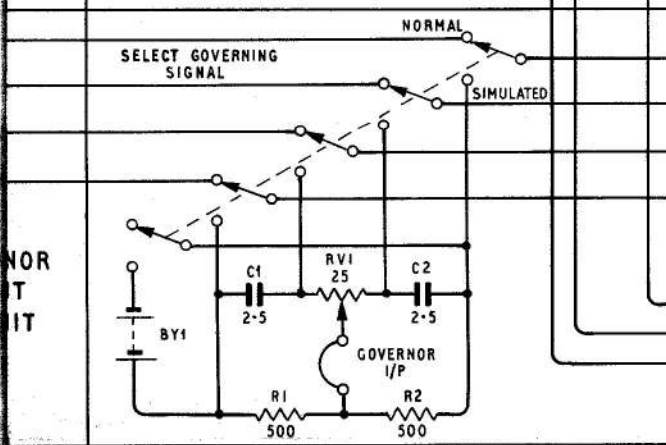
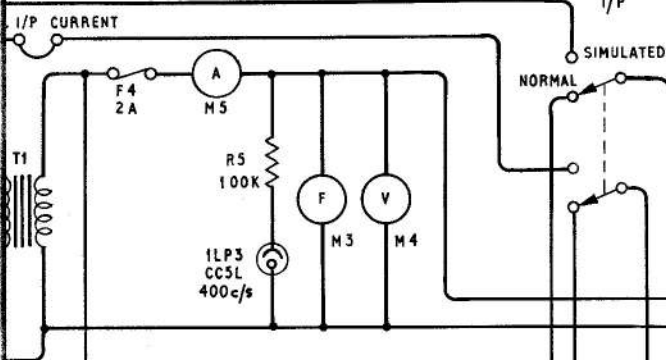

NOR
T
IT

DUMMY THROTTLE
MOTOR



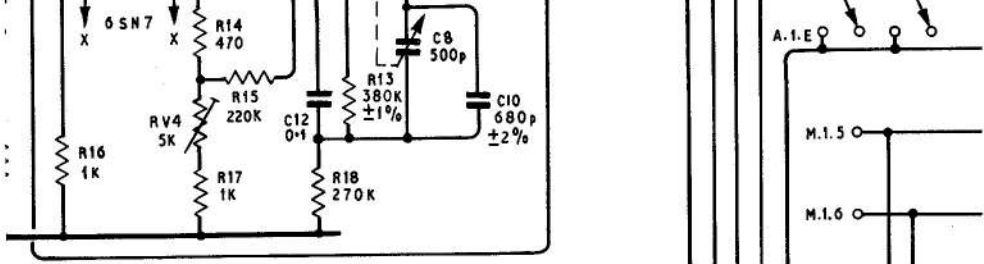

INPUT 400 c/s SUPPLY MONITORING CIRCUIT

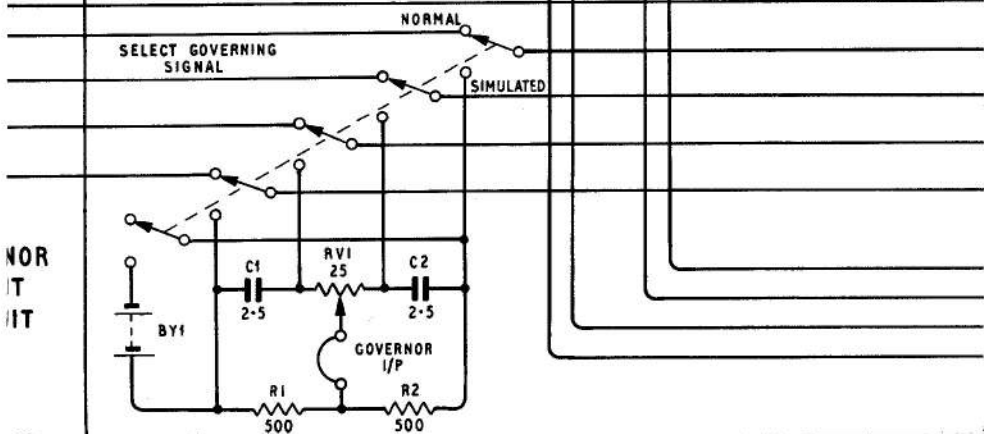
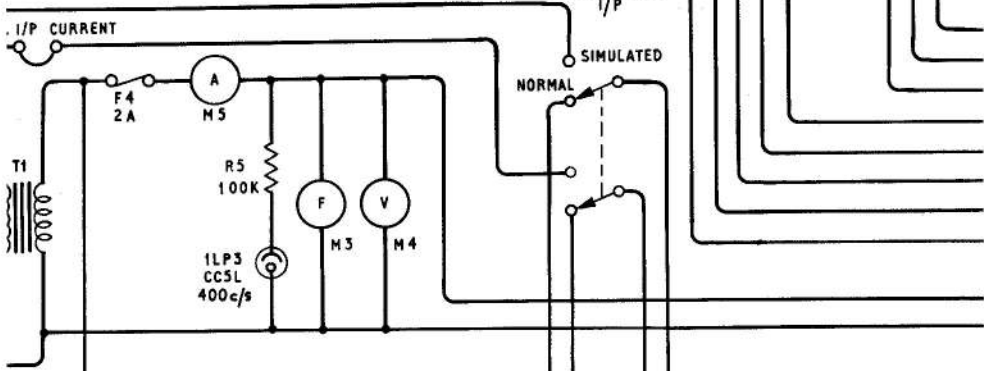
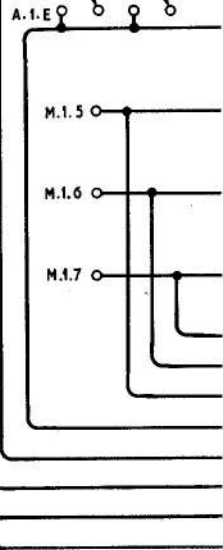

NOR
IT
IT

DUMMY THROTTLE MOTOR

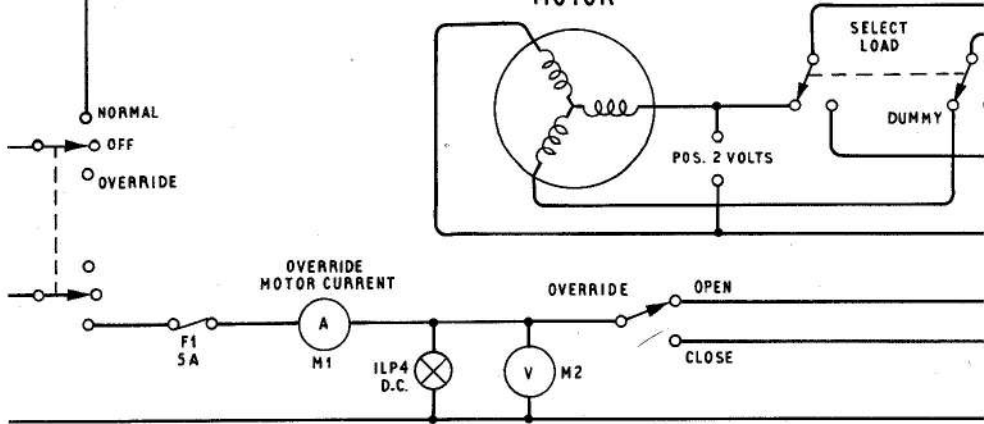

28 V.D.C. SUPPLY MONITORING CIRCUIT

diagram of test set, Type QT4066
RESTRICTED

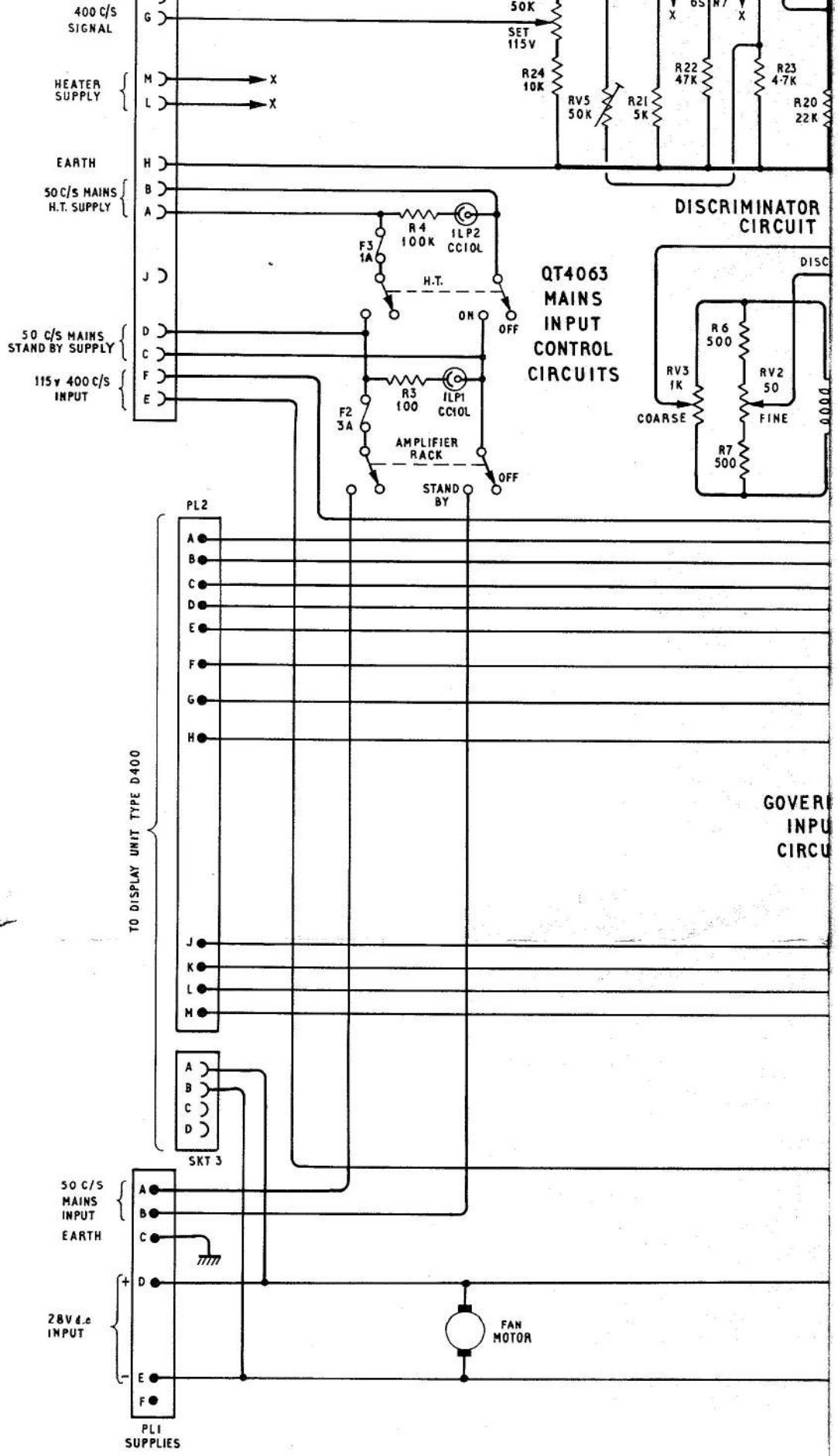

Fig. 7

G.C.M.-372588 - 22-7-64

Circuit

A.P. 4343K, Vol. 1, Sect. 10, Chap. 5
A.L. 22, June 64

SAFETY CIRCUITS TEST
SWITCHES

B.A.P.3 UNITS
SKT 2

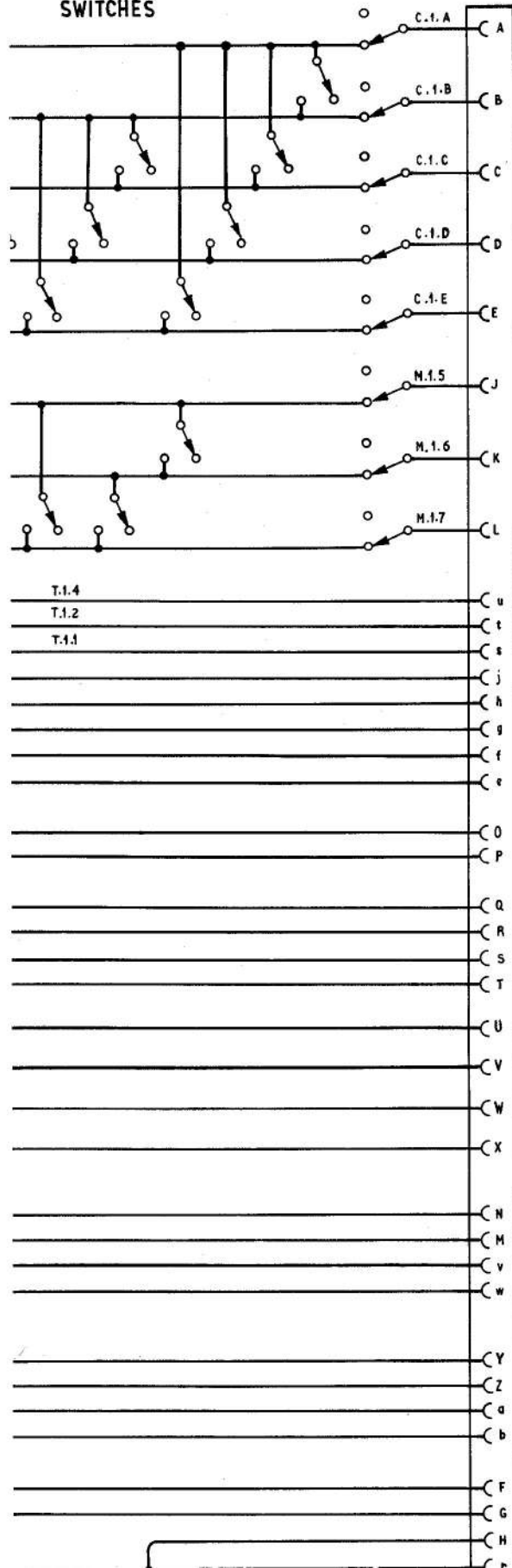

400 c/s
OSCILLATOR

SA

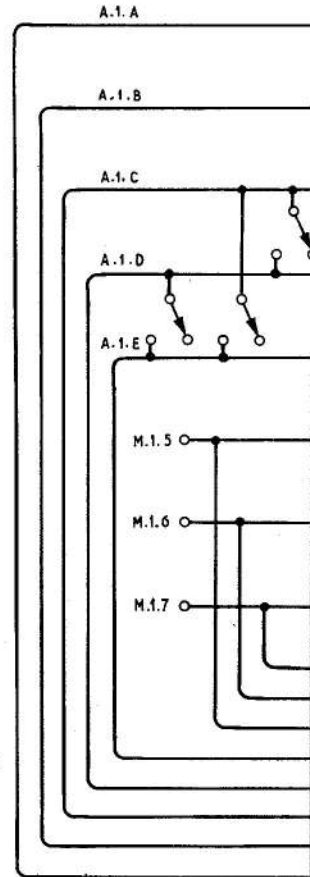
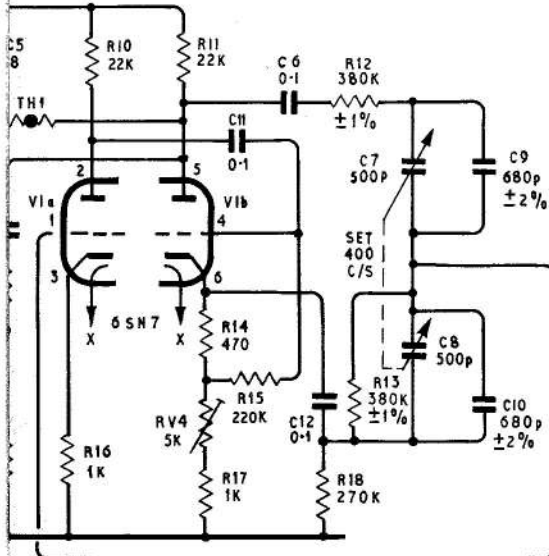

INPUT 400 c/s SUPPLY MONITORING
CIRCUIT

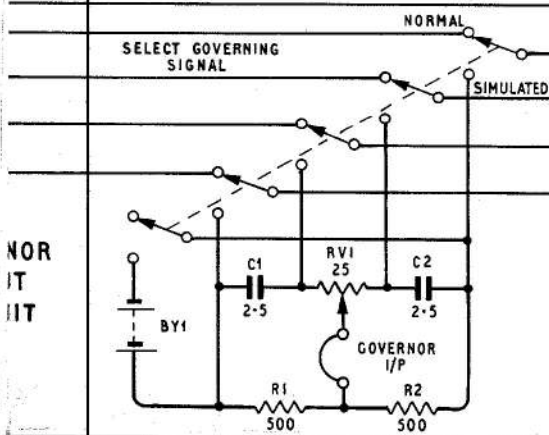
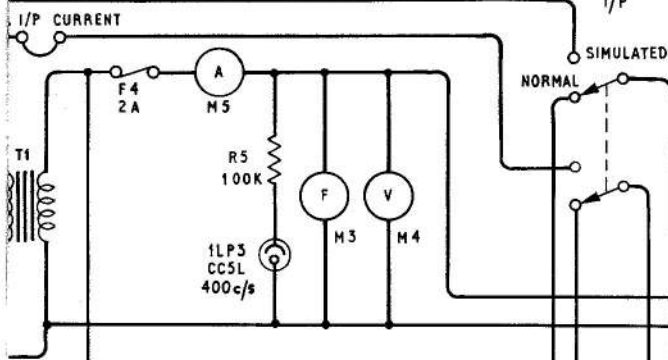

NOR
IT
IT

DUMMY THROTTLE
MOTOR



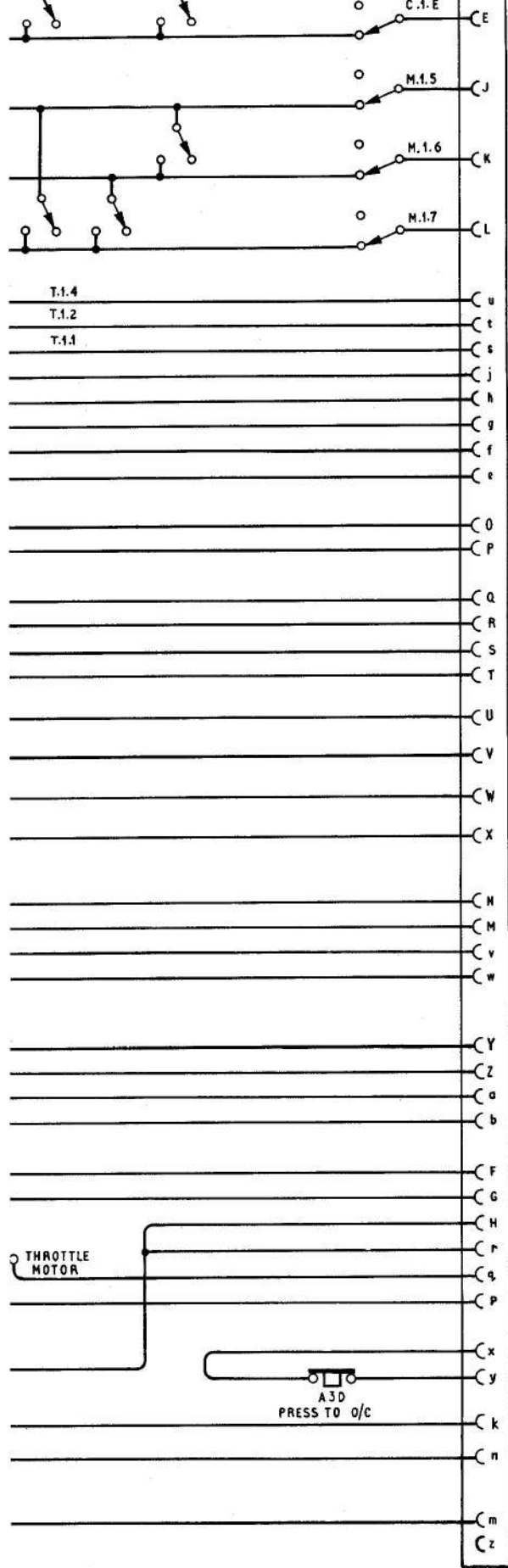

Fig.7

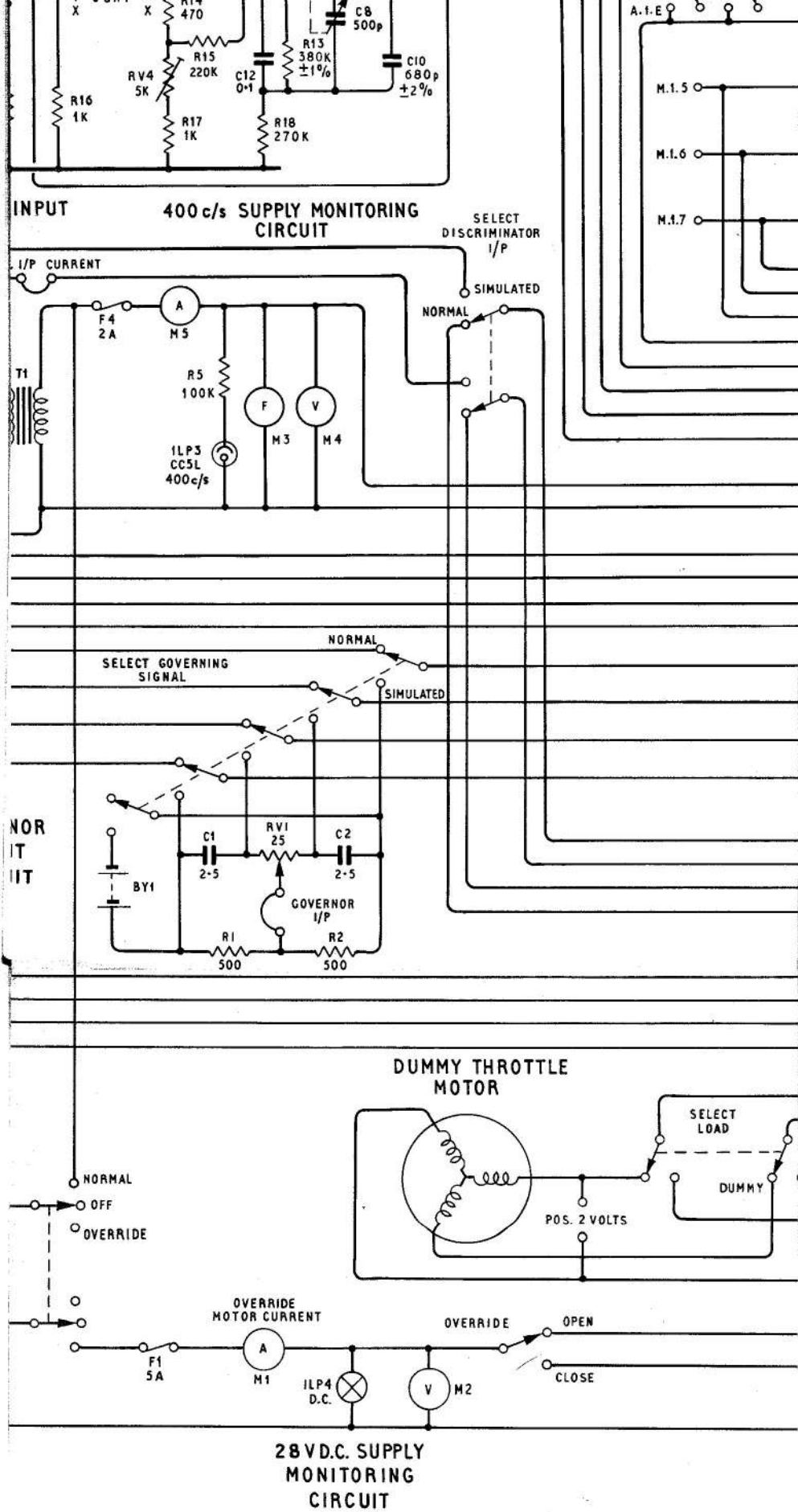

diagram of test set, Type QT4066
RESTRICTED

CANCELLED
 Now AP 120F-204-1.

Appendix 1

ANCILLARY TEST EQUIPMENT USED WITH TEST SET, ULTRA, TYPE QT4066

LIST OF CONTENTS

	<i>Para.</i>		<i>Para.</i>
<i>Introduction</i>	1	<i>Transmitter jig</i>	10
<i>Test equipment, Ultra, Type Q2A8</i>	2	<i>Throttle motor jig</i>	11
<i>Power amplifier, Ultra, Type QT4066</i>	4	<i>Galvanometer and terminals</i>	12
<i>Slave B.A.P.3 units</i>	5	<i>Display unit, Ultra, Type D400</i>	13
<i>Engine speed indicator</i>	6	<i>Power supply contactors</i>	14
<i>Dummy thermocouples</i>	7	<i>Portable potentiometer</i>	15
<i>Dummy C.J.C. unit</i>	8	<i>Adaptor box, Ultra, Type QY4022</i>	16
<i>Socket for engine speed signal</i>	9		

LIST OF ILLUSTRATIONS

	<i>Fig.</i>		<i>Fig.</i>
<i>Layout of test bench</i>	1	<i>Slave throttle motor in test jig</i>	3
<i>Slave transmitter in test jig</i>	2		

Introduction

1. Para. 1 of the main Chapter lists the ancillary equipment which is used with the test set to perform bench tests on the individual units of the B.A.P.3 system. The layout of the test bench is illustrated in fig. 1 and the following items are shown:—

- (1) Test equipment, Ultra, Type Q2A8
- (2) Power amplifier, Ultra, Type QT 4063 (3 off)
- (3) Slave amplifier, Ultra, Type A401/3
- (4) Slave transmitter, Ultra, Type T401/1
- (5) Slave throttle motor, Ultra, Type M174/1
- (6) Slave C.J.C. unit, Ultra, Type C402

- (7) Engine speed indicator
- (8) Starting switch for engine speed indicator
- (9) Dummy thermocouples
- (10) Dummy C.J.C. unit
- (11) Socket for engine speed signal
- (12) Transmitter jig
- (13) Throttle motor jig
- (14) Galvanometer and terminals
- (15) Display unit, Ultra, Type D400
- (16) Power supply contactors

Not shown in fig. 1 are the portable potentiometer and the adaptor box, Ultra, Type QY4022. Fig. 2 in the main Chapter

RESTRICTED

illustrates the electrical interconnections between the above units.

Test equipment, Ultra, Type Q2A8

2. This is a speed signal source with provision for accurate measurement of either the engine speed signal in an aircraft or the simulated speed signal fed to a speed control system. The speed source is described in A.P.4343K, Vol. 1, Sect. 10, Chap. 7. In the B.A.P.3 bench test rig, the equipment is used as a speed signal source when testing the amplifier, transmitter and datum selector. The speed measurement facility is not used for these tests, measurement of the speed signal being accomplished by means of the engine speed indicator (para. 6).

3. The equipment is in two parts. The control unit, Type QC2A80, is mounted on the left-hand equipment panel (*fig. 1*) and the motor unit, Type QM2A80, is mounted vertically behind the same panel. A 28V d.c. power supply is connected to the control unit. The speed signal output appears at a co-axial socket on the panel and is connected to the slave B.A.P.3 system by a co-axial cable forming part of the test cableform.

Power amplifier, Ultra, Type QT4063

4. Three power amplifiers are used in this installation, and they are designated QT 4063/1, QT4063/2 and QT4063/3. The amplifiers are connected in parallel and are fed with the 400 c/s signal from the oscillator in the test set, Type QT4066. The common, 115V, 400 c/s output is fed back to the test set, Type QT4066, and thence via the test cableform to the slave amplifier, Type A401/3. The three amplifiers are mounted in a rack which is located under the bench top, as shown in *fig. 1*. Electrical connections to and from the rack are made via a multi-cored cable. A full description of the power amplifiers will be found in A.P.4343K, Vol. 1, Sect. 10, Chap. 6.

Slave B.A.P.3 units

5. The slave units, comprising an amplifier, a transmitter, a throttle motor and a C.J.C. unit, form the basis of the bench test rig. The unit to be tested is connected into the slave system in place of its slave counterpart. The slave units are connected to each other, and to the test set, Type QT4066, by the test cableform. A description of the slave units is given in the following A.P.s.

(1) Amplifier, Type A401/3—A.P.4343 K, Vol. 1, Sect. 4, Chap. 1

(2) Transmitter, Type T401/1—A.P. 4343K, Vol. 1, Sect. 5, Chap. 1

(3) Throttle motor, Type M174/1—A.P. 4343K, Vol. 1, Sect. 7, Chap. 1

(4) C.J.C. Unit, Type C402—A.P.4343 K, Vol. 1, Sect. 1, Chap. 1

Engine speed indicator

6. The indicator is of a similar type to that fitted in the aircraft. It is used, in conjunction with the speed source, Type Q2A8, to measure the simulated speed signal fed into the B.A.P.3 system. The indicator is connected to the speed source.

Dummy thermocouples

7. The engine jet-pipe thermocouples are simulated by a 3.2 ohm resistor located above the slave C.J.C. unit on the left-hand equipment panel. The resistor is connected to the thermocouple terminals of the slave C.J.C. unit for temperature safety circuit checks on the amplifier, Type A401/3.

Dummy C.J.C. unit

8. The dummy unit simulates the d.c. resistance characteristics of a normal C.J.C. unit at 0°C. The need for ambient temperature corrections, when checking the temperature circuits of the amplifier, Type A401/3, is thus avoided. The temperature input signal is obtained from, and measured by, the portable potentiometer (para. 15) used in conjunction with chromel/alumel thermocouple temperature—voltage tables.

Socket for engine speed signal

9. This is a co-axial socket mounted on the left-hand equipment panel. The simulated speed signal is fed to this socket from the motor unit, Type QM2A80, and a co-axial plug on the test cableform passes the signal to the amplifier Type A401/3.

Transmitter jig. (*fig. 2*)

10. The jig consists of a base plate, to which the transmitter is clamped, a protractor and pointer, and a crank handle. The actuating shaft of the transmitter protrudes through each side of the transmitter casing; the protractor is secured to one end of the shaft and the crank handle is secured to the other end. The pointer is clamped to the transmitter casing. Using the jig, transmitter angles can be measured to an accuracy of $\pm 0.5^\circ$.

RESTRICTED

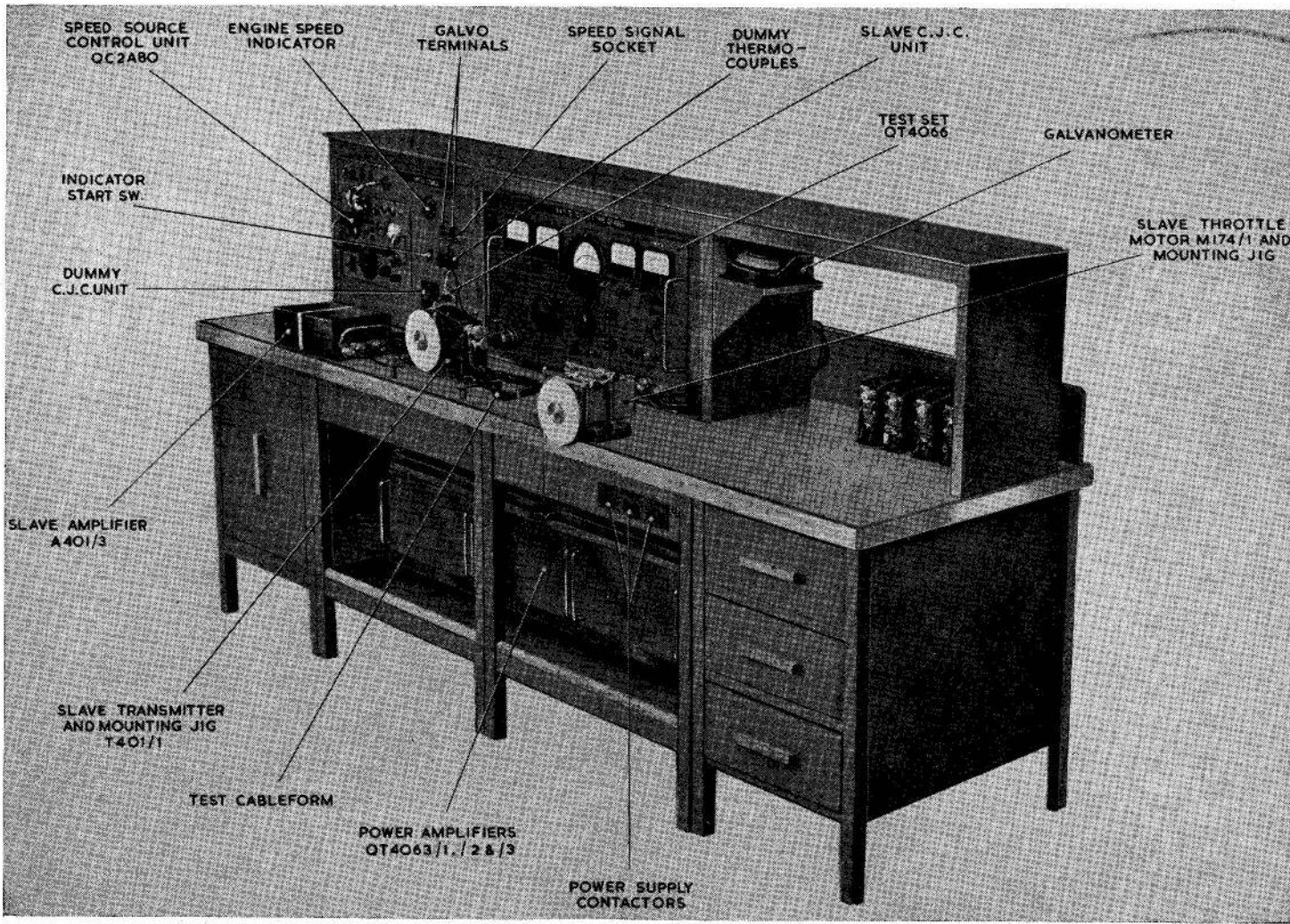

Fig. 1. Layout of test bench

RESTRICTED

Throttle motor jig (fig. 3)

11. The jig consists of a base plate, to which the throttle motor is clamped; a protractor and a set of weights. The protractor is secured to the output shaft of the throttle motor and a pointer, carried on pillars attached to the base plate, enables throttle motor angles to be measured to an accuracy of $\pm 0.5^\circ$. The protractor incorporates a six inch diameter pulley around which a cord is wrapped. Weights may be hung on this cord to provide various torque loads for the motor.

Galvanometer and terminals

12. The galvanometer is carried on a hinged platform to the right of the QT4066 panel. Connections to the galvanometer are made via two terminals located above the dummy thermocouples on the left-hand equipment panel. The galvanometer is used to determine the temperature reference datum of the B.A.P. 3 system.

Display unit, Ultra, Type D400

13. The display unit is mounted in an aperture in the front panel of the test set, Type QT4066. Electrical connections to the test set are made via a 12-pole socket and a 4-pole plug at the rear of the unit. The display unit comprises a trim indicator meter and a

failure warning lamp, similar to those fitted in the aircraft, together with a potentiometer and switch to simulate one channel of the datum selector unit, Type D401. The switch selects R.P.M. GOVERNING ON or OFF and the potentiometer sets the datum R.P.M.

Power supply contactors

14. In the installation illustrated, three contactors are fitted, but only two of these are used. The left-hand contactor controls the 115V, 50 c/s supply to the test set, Type QT4066. The right-hand contactor controls the 28V d.c. supply to the test set, Type QT4066; and to the speed source, Type Q2A8. The centre contactor (112V d.c.) is not connected.

Portable potentiometer

15. The portable potentiometer is used as a temperature signal source when testing C.J.C. units and amplifiers. In the installation under discussion, a Cambridge Workshop Potentiometer is used, but any other instrument of comparable range and accuracy is suitable.

Adaptor box, Ultra, Type QY4022

16. The adaptor box is used when testing datum selector units, Type D401. The box consists of a metal case on which are mounted

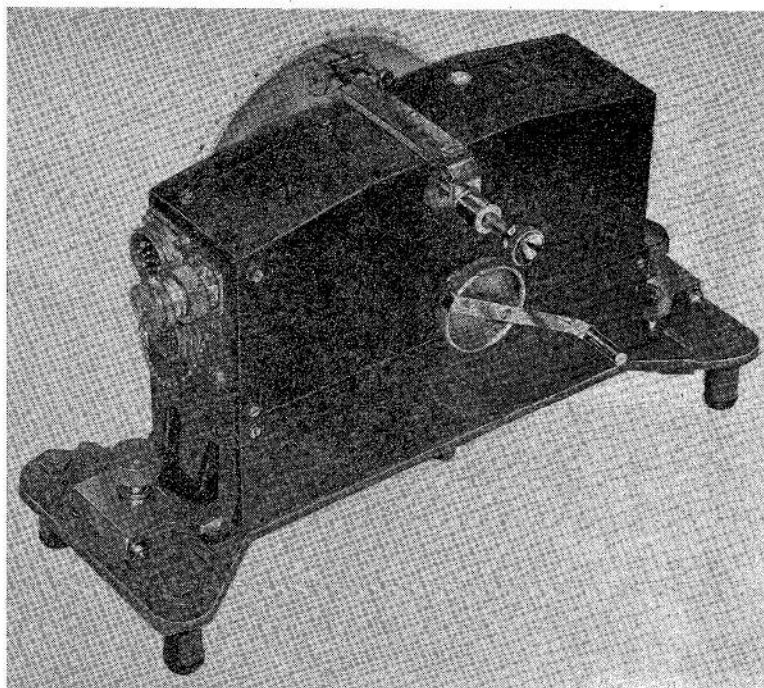

Fig. 2. Slave transmitter in test jig

RESTRICTED

two 12-way plugs. Extending from the case is a short cable terminating in a 12-way socket. The two plugs and the socket are wired in

parallel. The adaptor box and datum selector unit are connected to the test set and transmitter as shown in fig. 2 in the main chapter.

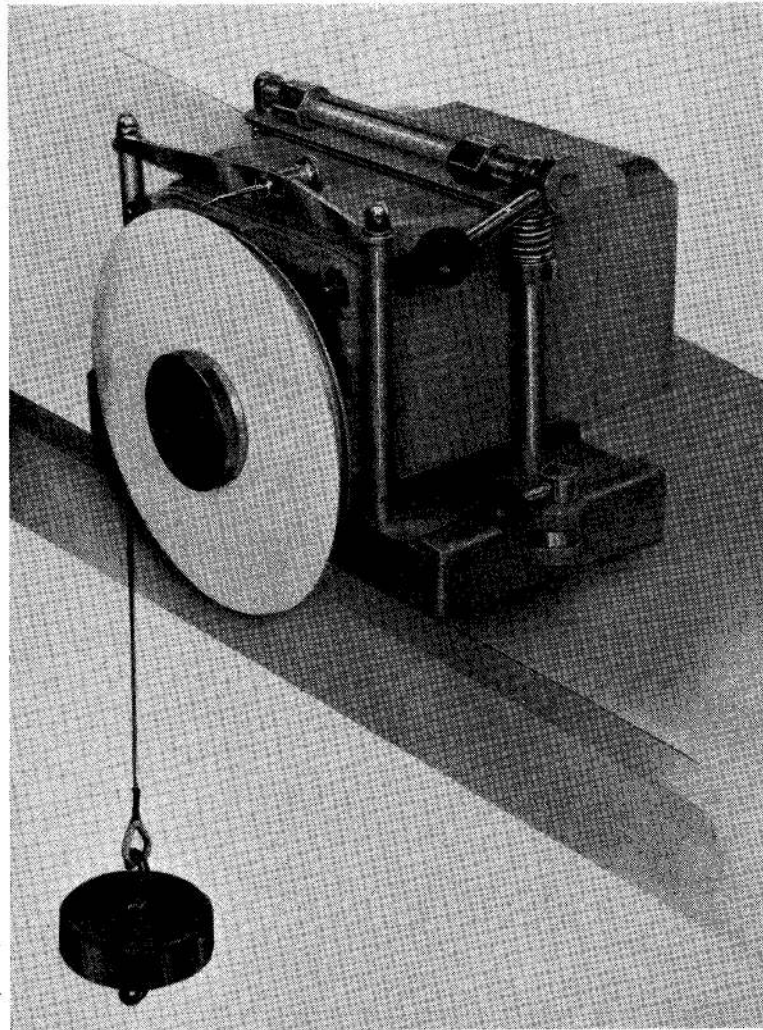
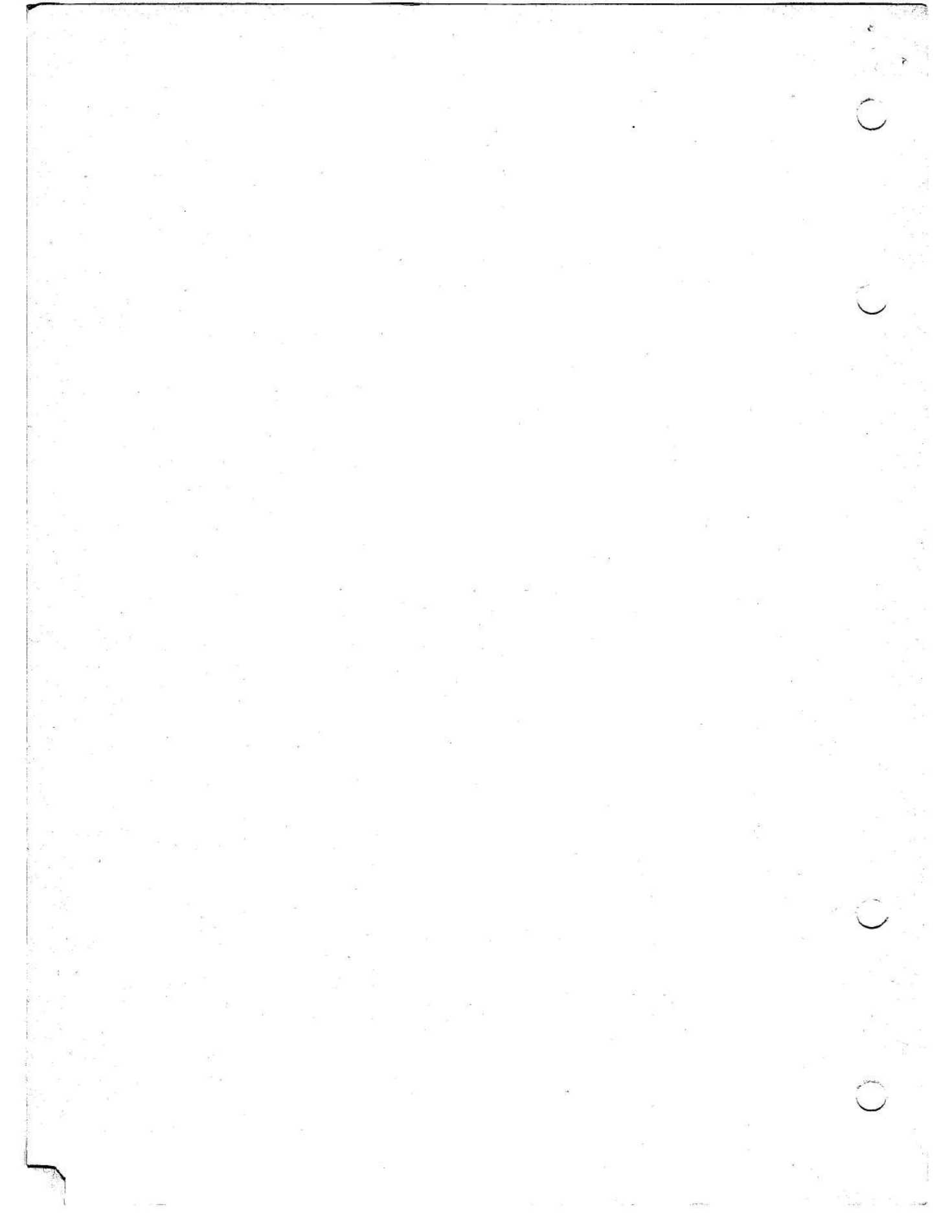

Fig. 3. Slave throttle motor in test jig

RESTRICTED



This file was downloaded
from the RTFM Library.

Link: www.scottbouch.com/rtfm

Please see site for usage terms,
and more aircraft documents.

