

*Cancelled,
now
obsolete*

Chapter 6

LIST OF CONTENTS

	<i>Para.</i>		<i>Para.</i>
<i>Introduction</i>	1	<i>Power supply</i>	14
Description	4	<i>Test connections</i>	15
Circuit Description	7	<i>Output</i>	16
Servicing		<i>Bias</i>	17
<i>Test equipment</i>	13	<i>Fault finding</i>	18

LIST OF ILLUSTRATIONS

	<i>Fig.</i>		<i>Fig.</i>
<i>Power amplifier, Ultra, Type QT4063</i> ...	1	<i>QT4063</i>	3
<i>Interconnections of QT4063 units</i> ...	2	<i>Test connections</i>	4
<i>Circuit diagram of power amplifier, Type</i>		<i>Component location diagram</i>	5

LIST OF TABLES

	<i>Table</i>
<i>Circuit voltages</i>	1

LEADING PARTICULARS

Power amplifier, Ultra, Type QT4063	Ref. No. 5G/3285
<i>Output (nominal)</i>	115V, 400 c/s 1-ph
<i>Output power</i>	up to 50VA
<i>Input voltages</i>	(a) approx. 0.5V, 100 to 600 c/s (b) 110 to 120V, 50 c/s or 200 to 250V, 50 c/s
<i>Input current from 50 c/s supply</i>	up to 1A (115V supply) up to ½A (230V supply)
<i>Overall dimensions</i>	19in. × 12in. × 22in.

RESTRICTED

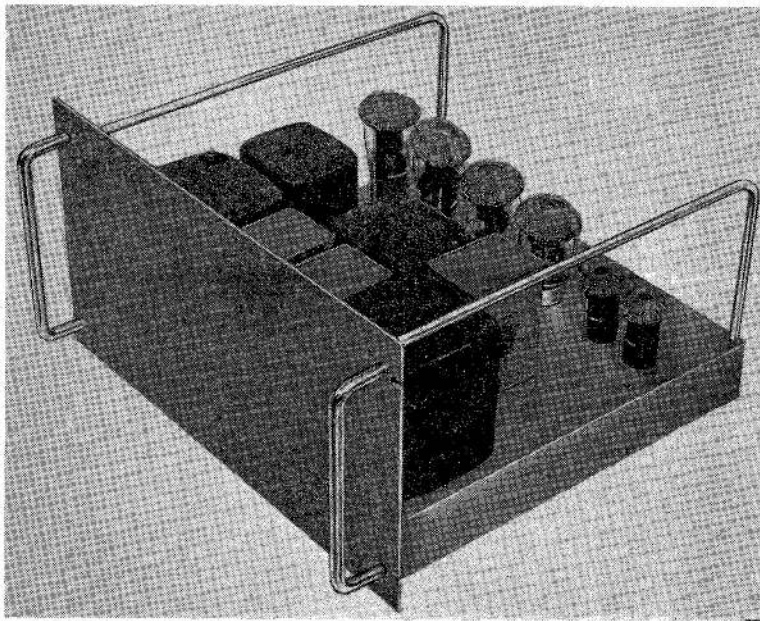

Fig. 1. Power Amplifier, Ultra, Type QT4063

Introduction

1. Power amplifier. Type QT4063 (*fig. 1*) is a 400 c/s power amplifier capable of providing a power output of 50VA. The amplifier is controlled by a 400 c/s signal from a separate, Wien bridge oscillator, in test set QT4066, and operates from a 115V or 230V (nominal) mains supply.

2. The amplifier has a fixed gain, the amplitude of the output voltage being dependent on the amplitude of the 400 c/s input signal. Similarly, the output frequency is dependent on the input frequency, which may be 100 to 600 c/s.

3. Two or more amplifiers may have their output terminals connected in parallel when load currents higher than 450mA are required. When used with test set, Type QT4066, three amplifiers, Type QT4063, are connected in parallel and are fed from a common 400 c/s signal generator in the test set. In this installation the amplifiers are designated QT4063/1, /2 and /3; an interconnection diagram is given in *fig. 2*.

DESCRIPTION

4. The amplifier, Type QT4063 is intended for rack mounting. It consists of a chassis assembly, on which all the electrical compo-

nents are mounted, secured to the front panel which may, in turn, be secured to the mounting rack.

5. Electrical connections to the amplifier are made via a Plessey Mk. 4 plug and two Mk. 4 Plessey sockets located at the rear of the chassis, as shown in *fig. 5*.

(1) Two-pole socket (SK1) for the output voltage.

(2) Six-pole socket (SK2) for the input voltage.

(3) Four-pole plug (PL1) for the mains supply.

6. There are no operating controls but two preset potentiometers, RV1 and RV2, are mounted on the chassis. These are used, during the setting up of the amplifier, to adjust the current sharing of the output valves.

CIRCUIT DESCRIPTION

7. The 400 c/s signal, from the external signal generator, is fed from pin A of SK2, via C1, to the grid of amplifier V1a (*fig. 3*). In installations where the output of the amplifier is used to drive a synchronous motor, C1 compensates for the variable input impedance characteristic of the motor.

RESTRICTED

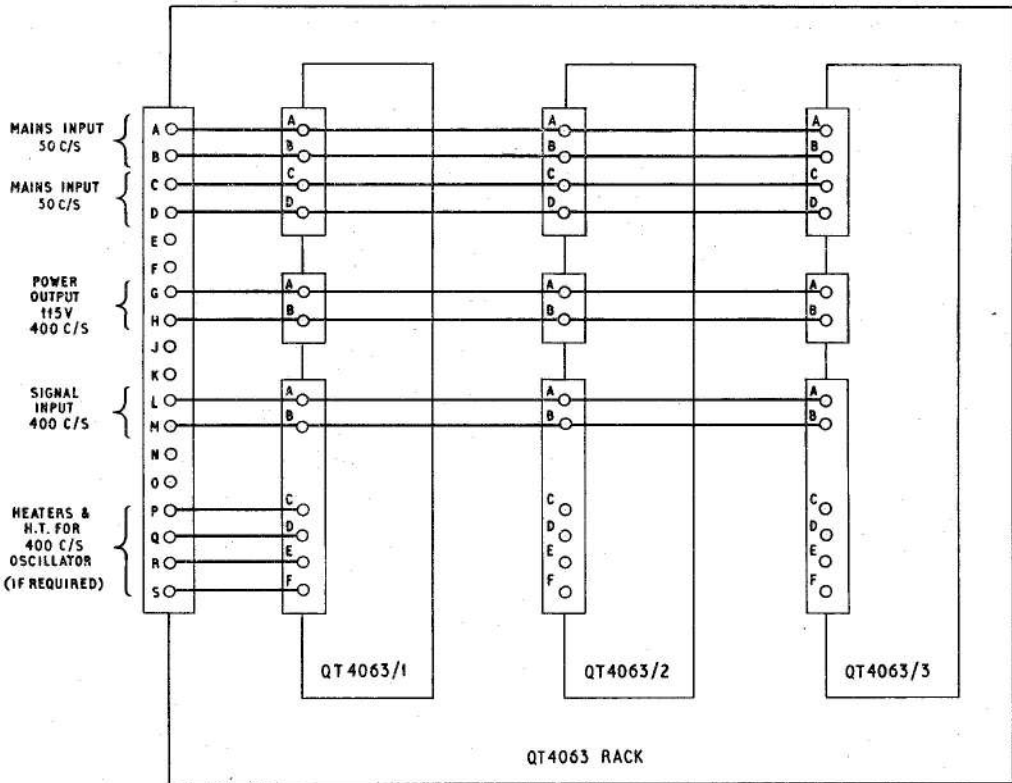

Fig. 2. Interconnections of QT4063 units

The output voltage thus remains constant over a wide range of frequency.

8. The output of V1a is fed to the phase-splitter V1b. Antiphase signals are taken from the anode and cathode of V1b via C5 and C6, to the grids of the driver amplifier V2a and V2b respectively. The outputs from V2 anodes are fed, via C8, R16 and C7, R21, to the output stage V3 and V4. These valves operate in class AB1 push-pull and feed the primary winding of the output transformer T3. The output of the amplifier is obtained from the secondary winding of T3 and is fed to pins A and B of SK1. Negative feedback is applied to the first amplifier, V1a, via R30, R5 and R2.

9. A negative d.c. bias supply is derived from the h.t. transformer secondary via C14 and MR1. This supply is smoothed by C13 and fed to the two preset potentiometers RV1 and RV2. Grid bias for valves V3 and V4 is

obtained from the wipers of these potentiometers, which are adjusted so that the cathode voltages of V3 and V4 are equal. This ensures equal current sharing between the output valves. The outputs from each of the three power amplifiers are connected in parallel as shown in fig. 2.

10. The amplifier h.t. supply is derived from transformer T1, via rectifiers V5 and V6. The h.t. supply is smoothed by L1, C10, C11 and C12 and decoupling for the h.t. dropper resistors R7, R9 and R22 is provided by C3, C4 and C9.

11. The heater supply for rectifiers V5 and V6 is obtained from the 5V secondary winding of transformer T2. This supply is fed via the thermal delay switch S1, which introduces a time delay of approximately 90 seconds. This ensures that the h.t. supply is not switched on until the heaters of valves V1, V2, V3 and V4 have warmed up.

RESTRICTED

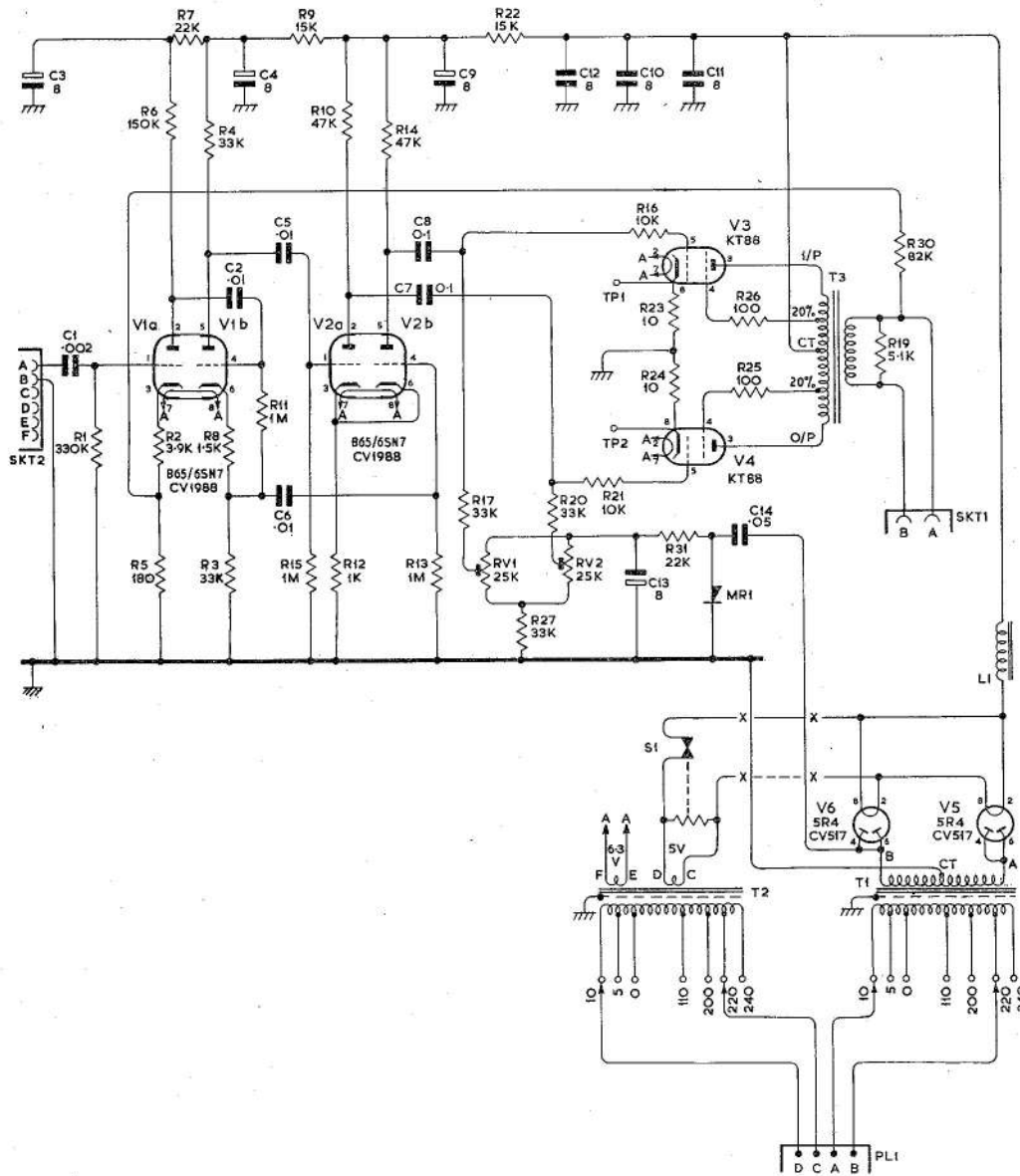

Fig. 3. Circuit diagram of power amplifier, Type QT4063

12. The primary windings of transformers T1 and T2 have tappings enabling the amplifier to be used on supplies of 110 to 120V or 200 to 250V, 50 c/s. The primary windings of T1 and T2 are connected to pins A, B, C and D of PL1. Pins C and D are connected to the 50 c/s supply via the 'STANDBY' switch and pins A and B are connected to the 50 c/s supply via an 'H.T.' switch. Both these switches are located on test set, Type QT4066.

SERVICING

Test equipment

13. The following test equipment is required:—

- (1) 100 ohm, 150W resistor
- (2) Oscilloscope (Cossor Type 1058)
- (3) Multimeter, Type 12889

RESTRICTED

- (4) 400 c/s oscillator (in test set, Type QT4066)

Power Supply

14. A 200 to 250V, 50 c/s or a 110V to 120V, 50 c/s mains supply is required.

Test connections

15. Set the two voltage selectors on the power amplifier to suit the mains supply in use. Connect the test equipment and power supply as shown in fig. 4. Note that when a three-amplifier installation is being tested, only one amplifier should be connected at a time.

Output

16. (1) Switch on the mains supply.
(2) Set the AMPLIFIER RACK switch to STANDBY and, two minutes later, set the H.T. switch to ON.
(3) When the H.T. supply lamp lights set the voltage and frequency of the supply to 115V, 400 c/s.
(4) Connect the 100 ohm resistor between poles O and P of the 48-way B.A.P.3 UNITS socket.
(5) Connect the oscilloscope across the 100 ohm resistor and adjust the oscilloscope attenuator and timebase so as to display two cycles of the output waveform.

- (6) Measure the output frequency and check that, between 350 c/s and 450 c/s, the output waveform is sinusoidal. As a comparison, the waveform of the 50 c/s mains may be displayed.

Bias

17. (1) With the test equipment set up as in para. 16 but with valve V1 removed, connect the Multimeter, on the 2.5V d.c. range between test point 1 (+ve) and chassis (see fig. 5).
(2) Adjust RV1 to obtain a reading of $0.55V \pm 0.05V$ on the Multimeter.
(3) Transfer the +ve lead of the Multimeter to test point 2 and adjust RV2 to obtain a reading of $0.55V \pm 0.05V$.
(4) The settings of RV1 and RV2 are interdependent and it may be necessary to repeat sub-para. (2) and (3) until balance is obtained.

Fault finding

18. If either of the above tests yield unsatisfactory results, or if the 400 c/s power output fails when the amplifier is in operation, carry out a wiring continuity check on the amplifier. Reference to the circuit diagram, fig. 3, and the component location diagram, fig. 5, will enable each component to be checked.

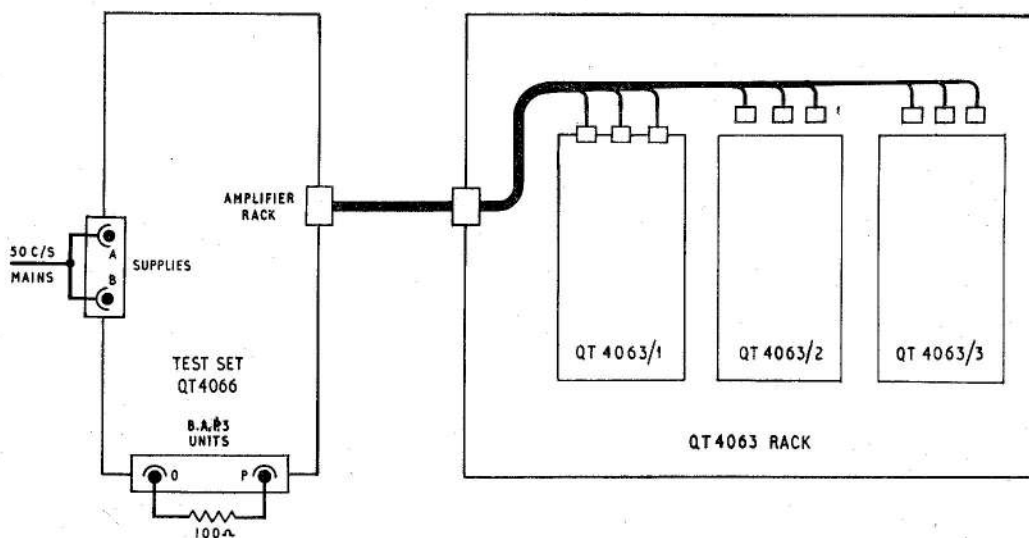

Fig. 4. Test connections

RESTRICTED

19. The readings should be obtained on a power amplifier with open circuited input and output connections. A 50 c/s mains supply should be fed into the nut on poles A and B of PL1. Pole A should be linked to pole D; pole B should be linked to pole C.

Caution . . .

If it is found necessary to renew resistors R23 or R24, the power rating of the replacements must not exceed 1/2W. Typical circuit voltages are given in Table 1.

TABLE 1

Circuit voltages (fig. 3)

Meter range	+ve lead	-ve lead	Voltage
1000V a.c.	V5 pin 6	chassis	630V
1000V a.c.	V6 pin 6	chassis	630V
1000V d.c.	T3 CT	chassis	520V
1000V d.c.	V3 pin 3	chassis	518V
1000V d.c.	V4 pin 3	chassis	518V
2.5V d.c.	V3 pin 8	chassis	0.6V
2.5V d.c.	V4 pin 8	chassis	0.6V
100V d.c.	chassis	C13(-ve end)	73V
250V d.c.	V2 pin 2	chassis	194V
250V d.c.	V2 pin 5	chassis	194V
10V d.c.	V2 pin 3	chassis	6.5V
250V d.c.	V1 pin 2	chassis	119V
250V d.c.	V1 pin 5	chassis	215V
10V d.c.	V1 pin 3	chassis	4.8V
100V d.c.	V1 pin 6	chassis	93V
10V a.c.	V1 pin 7	V1 pin 8	6.3V
10V a.c.	V6 pin 2	V6 pin 8	5V
1000V d.c.	C3 (+ve end)	chassis	286V

RESTRICTED

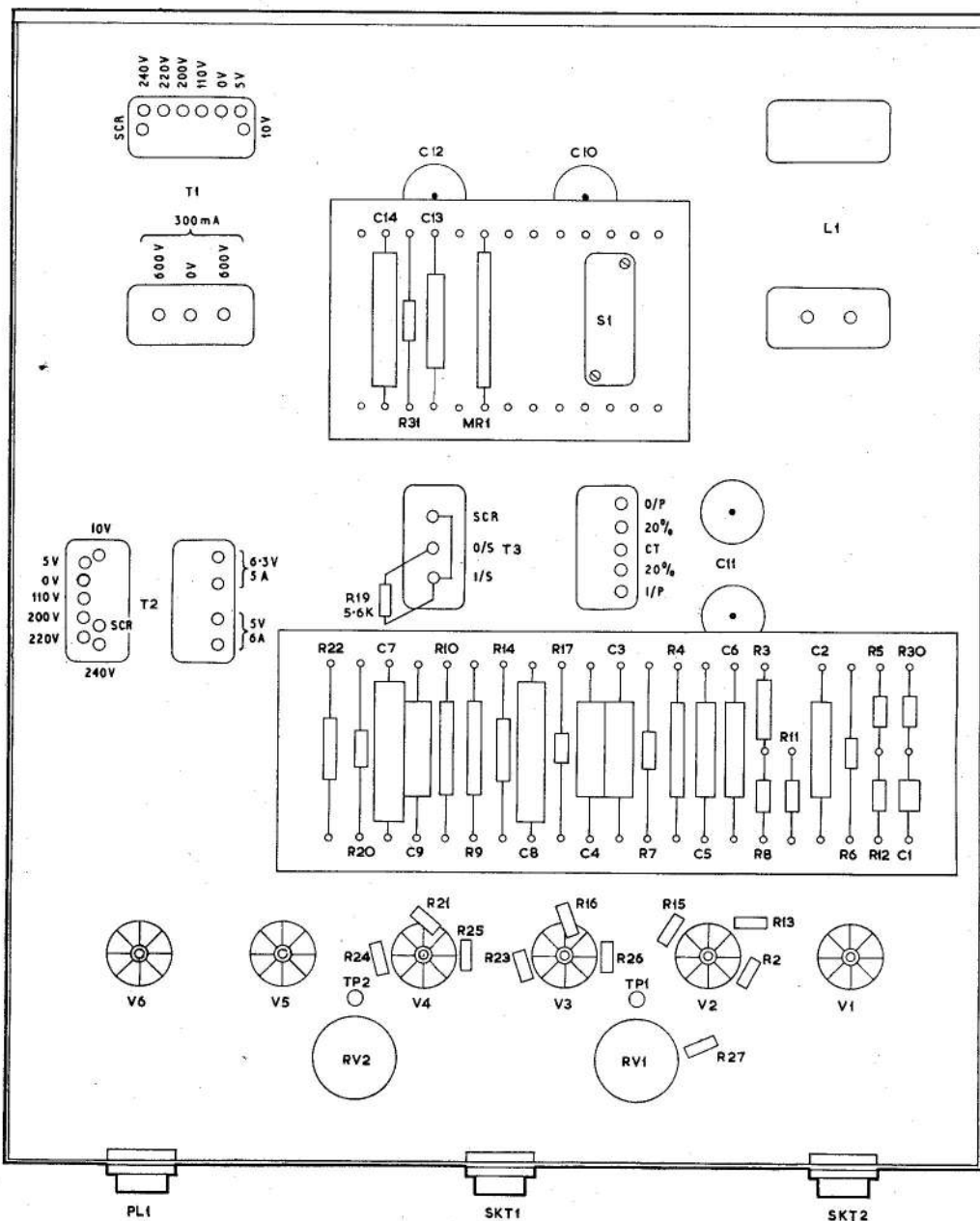
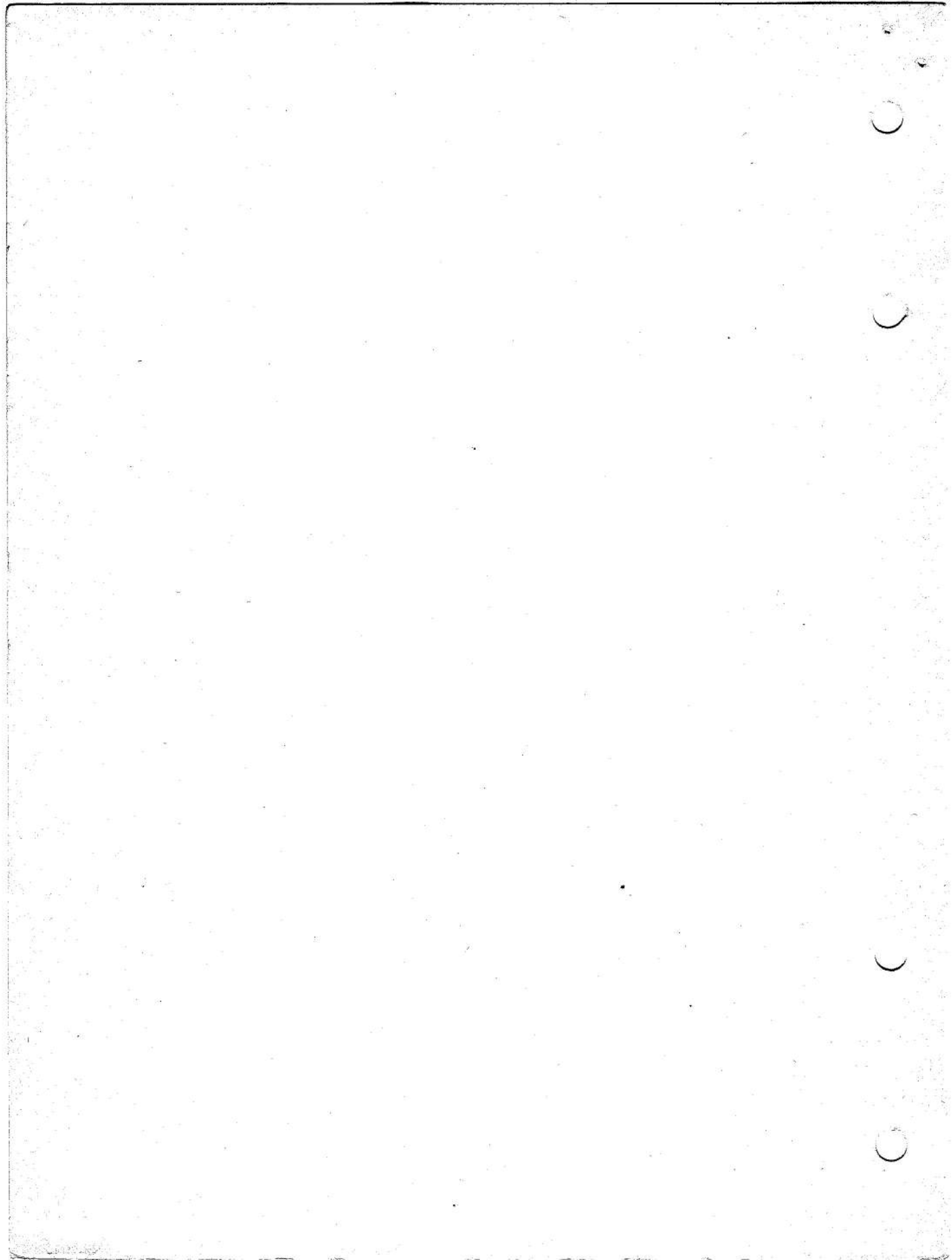

Fig. 5. Component location diagram

RESTRICTED



This file was downloaded
from the RTFM Library.

Link: www.scottbouch.com/rtfm

Please see site for usage terms,
and more aircraft documents.

