

*Cancelled
New 113-F-0411-1*

Chapter 1

AMPLIFIER UNITS SMITHS, TYPE EC1/6 and EC1/7

LIST OF CONTENTS

	Para.		Para.
<i>Introduction</i>	1	<i>Testing</i>	14
Description	2	<i>Connections</i>	15
Operation		<i>Test set batteries</i>	17
<i>Reference voltage</i>	4	<i>Power supplies</i>	18
<i>First stage</i>	5	<i>Removal of test cable QY2216</i>	19
<i>Second stage</i>	9	<i>Test set preparation</i>	20
<i>Output stage</i>	11	<i>Amplifier datum test</i>	21
<i>Negative feedback</i>	12	<i>Gain</i>	22
Servicing		<i>Time response</i>	23
<i>General</i>	13	<i>Insulation test</i>	24

LIST OF ILLUSTRATIONS

	Fig.		Fig.
<i>Amplifier, with cover removed</i>	1	<i>Bench test circuit</i>	4
<i>Underside of amplifier</i>	2	<i>Amplifier, EC1/6 circuit diagram</i>	5
<i>Block diagram of amplifier</i>	3		

LEADING PARTICULARS

<i>Amplifier unit, Smiths, Type EC1/6</i>	<i>Ref. No. 5CZ/5541</i>
<i>Amplifier unit, Smiths, Type EC1/7</i>	<i>Ref. No. 5CZ/6682</i>
<i>Output at datum temperature</i>	200mA
<i>Input voltage</i>	115V, 400c/s, 3ph.

Introduction

1. The EC1/6 and EC1/7 amplifiers are designed to control the fuel flow to an aircraft jet engine so that the jet pipe temperature is maintained at its optimum value. The two amplifiers are identical in all respects, but the EC1/7 code is given to the amplifiers used on Comet aircraft. The temperature is measured by a series of chromel-alumel thermocouples, mounted radially in the jet pipe and connected electrically in parallel. Any difference between the thermocouple

voltage and the reference voltage of the system is amplified to operate a solenoid controlling a valve in the fuel supply to the engine. This valve is a by-pass to the fuel pump so that when open it reduces the fuel supplied to the engine. When the jet pipe temperature rises above its optimum value, the solenoid is energized and the control valve is held open against the spring. The solenoid is de-energized and the valve is returned to a partly open position when the jet pipe temperature falls to its optimum value.

RESTRICTED

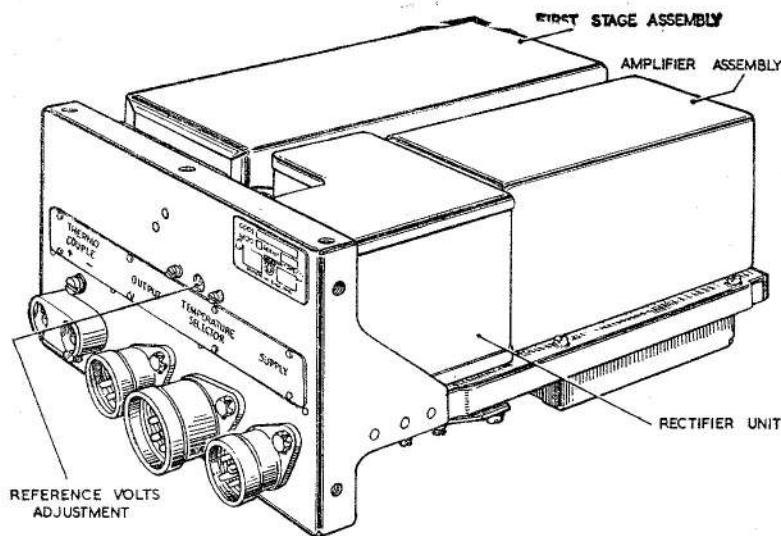

Fig. 1. Amplifier, with cover removed

DESCRIPTION

2. The components of the amplifier are mounted on a fabricated aluminium alloy chassis which is attached to the front panel. The whole assembly may be withdrawn from the cover after removing the four securing screws. The first stage assembly, amplifier assembly and rectifier unit are mounted above the chassis (fig. 1), and the reference voltage unit and feedback unit below the chassis (fig. 2). These sub-assemblies are contained in metal cases sealed against the ingress of moisture.

3. The cold junction compensator is wound on the thermocouple terminal assembly in the front panel, the front panel is itself the cold junction. The bias voltage of the transducers is supplied from the rectifier and capacitor arrangement which is mounted, together with a variable resistor, behind the front panel, and above the chassis. The variable resistor adjusts the reference-voltage of the system, the spindle is accessible through the front panel and is slotted for screwdriver adjustment. The rectifier assembly, located between the reference voltage and feedback units, supplies the reference voltage unit. The external connections to the amplifier are made on the front panel

through Plessey Mk.3 connectors, and for the thermocouple leads screw terminals. A temperature selector, of the correct value for operation of the system concerned, is fitted into the plug provided on the front panel.

OPERATION

Reference voltage

4. The reference voltage is derived from a resistance network, supplied by transformer TR5 to the rectifiers assembly and stabilized by the neon V1 (fig. 3 and 5). One arm of the resistance network includes the temperature selector, the value of which is chosen to provide the correct operating temperature for the system. The thermocouple voltage is compared with the reference voltage and the resultant signal is applied to the control winding of transducer X2 in the first stage of the amplifier. There is no input in the amplifier when the thermocouple e.m.f. balances the reference voltage. A resistor R14 across the thermocouple terminals prevents maximum fuel delivery to the engine in the event of the thermocouples becoming open-circuited. The resistors forming the voltage reference network include a cold junction compensator R13, to allow for changes in ambient temperature of the

RESTRICTED

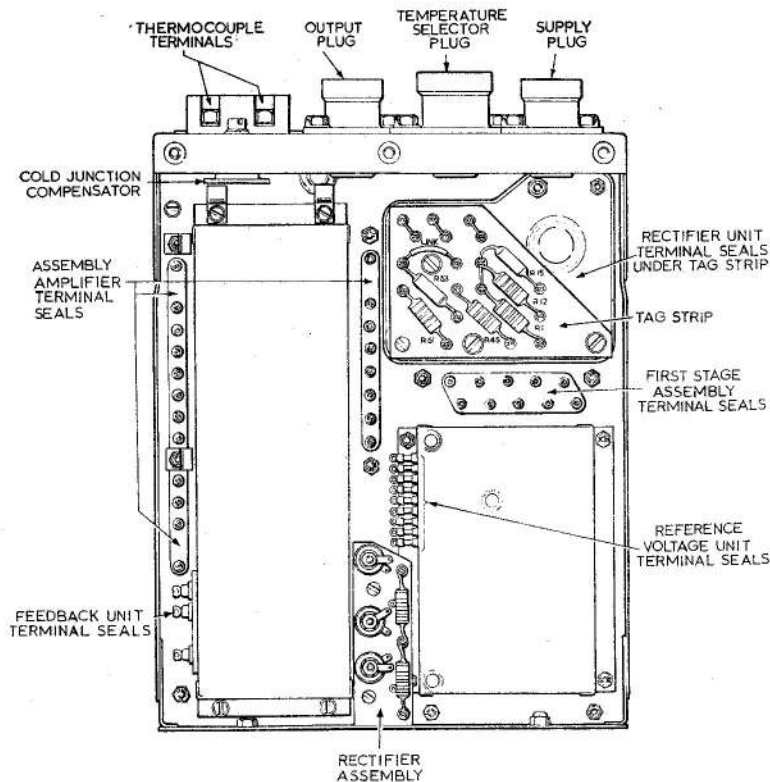

Fig. 2. Underside of amplifier

thermocouple cold junction, and a variable resistor R16-34 to provide an adjustment for the reference voltage prior to installation.

First stage

5. The signal from the reference voltage unit is applied to the control winding of the signal transducer X2 through the choke L1. The phase reference transducer X1 is controlled by a steady d.c. bias voltage, obtained

from the rectifier bridge MR2 through resistor R36. Choke L1 and resistor R36 are included to suppress the double frequency (second harmonic) current pulses which are induced into the control windings by the main exciting winding.

6. The exciting windings of the two transducers are connected in series and supplied from the main transformer TR1 via capaci-

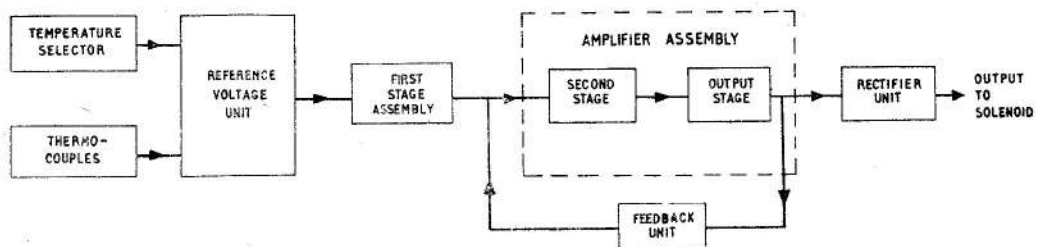

Fig. 3. Block diagram of amplifier

RESTRICTED

tor C2. The function of C2 is to limit the duration of the current pulses and so reduce the risk of overheating.

7. The output from this stage is supplied by an additional winding into which currents are induced by the main exciting winding, at double the supply frequency. The output windings of both transducers are connected across a phase sensitive rectifier network MR3-4-5-6, which functions as a synchronous switch. The steady output from X1 provides the reference phase and is loaded by resistor R39. By this arrangement the appropriate half of the output winding is connected to the output terminals and the sense of the input signal is preserved.

8. The output is developed across resistor R44, from where it is applied to the next stage. A voltage is also developed across the network R42, R43 and TH1, which supplies positive feedback to the transducer X2 via the smoothing choke L2.

Second stage

9. The second stage consists of two biased transducers, X3 and X4, connected in push-pull and provided with positive feedback. A choke L3 and capacitor C4 are included in the control circuit to smooth the input signal. The bias windings are supplied from the rectifier bridge MR2 and the output windings are connected in series across a secondary winding of the main transformer TR1. The auto-transformer TR2, connected between the centre-tap on the secondary winding of TR1 and the mid-point between the two transducer output windings, feeds the output to a phase sensitive rectifier network. This functions in a similar manner to the network used in the first stage, the appropriate half of the auto-transformer winding being switched across the output terminals of the stage. The reference supply to the bridge is taken from transformer TR1.

10. The output is developed between the centre-tap of auto-transformer TR2 and the centre-tap of the phase reference winding of TR1. The output circuit includes a voltage dropping resistance network R53, R54 and

TH2, across which is developed the positive feedback voltage for the transducers X3 and X4.

Output stage

11. The output stage has one transducer X5, the control circuit of which includes a choke L4 and smoothing capacitors C6 and C7. The transducer is excited from the secondary winding of transformer TR3 and the output is developed across the primary of the matching transformer TR4. The secondary winding of TR4 is connected to a rectifying bridge MR11, and the rectified signal to the output plug. The primary of TR4 is loaded by resistor R60 and capacitor C8, which improve the linearity of the output and compensates for the inductive load imposed by the fuel valve operating solenoid. A rectifying bridge MR12 is connected in the primary circuit of TR4 to provide positive feedback to the output transducer.

Negative feedback

12. Stable operation of the system is achieved by providing negative feedback from the output stage to the signal input to the second stage. The feedback supply is taken from the primary of the output transformer TR4, the current is rectified by MR13 and the feedback voltage is developed across the load resistor R52. This voltage is applied to the signal input to the second stage via a smoothing circuit R50, R51, C11 and C12, and capacitors C9 and C10, which ensure that the negative feedback operates only when the output signal from the amplifier is changing.

SERVICING

General

13. Examine the amplifier externally for damage, and corrosion. Remove the cover and examine the interior of the unit for damage, deterioration and security of the components. Replace the cover and test the amplifier as detailed below.

Testing

14. The following tests will check the datum temperature, gain and time response of the amplifier. The test equipment required is as follows:—

RESTRICTED

- (1) Test set, Ultra, Type QT223.
- (2) Nine-core test cable, Type QY2212.
- (3) Four-core test cable, Type QY2216.
- (4) A bench test rig made up as shown in fig. 4.
- (5) A 115V 3-phase, 400 c/s, supply.
- (6) Stop watch.
- (7) Temperature selector plug.

connect the commoning terminals to the test plug, similar leads must be used in the test rig. These leads must be made from Chromel and Alumel as shown in fig. 4.

16. In the test rig the thermocouple cluster is simulated by a resistor of equivalent resistance, and the resistor is connected to the amplifier terminals by Chromel-Alumel compensating leads. These leads should have a resistance equivalent to the leads used in the aircraft, or alternatively the actual aircraft leads may be used. It is important to ensure that the leads connecting the thermocouple

Connections

15. Since in the aircraft, compensating leads connect the amplifier input terminals to the thermocouple commoning terminals, and also

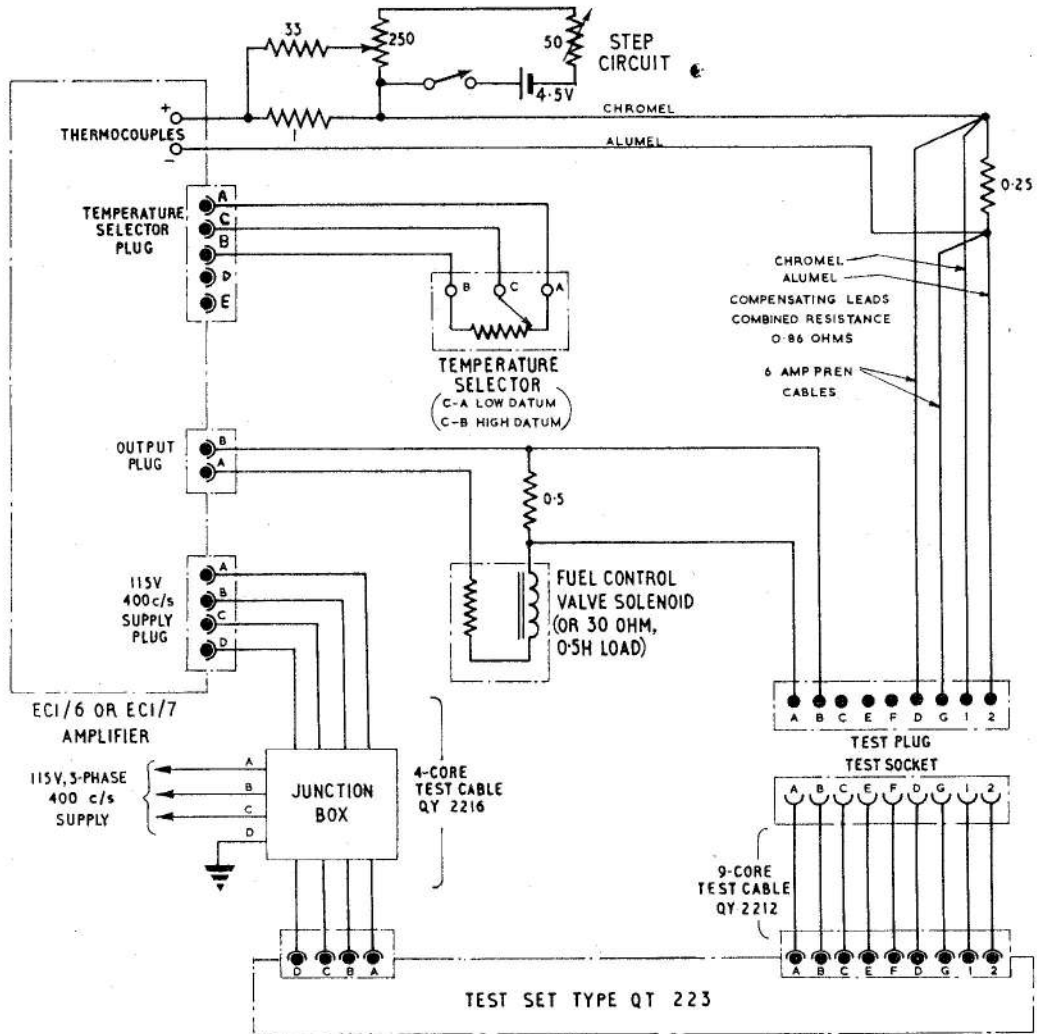

Fig. 4. Bench test circuit

RESTRICTED

simulating resistor make good electrical contact, since any additional resistance in the circuit will adversely affect the results.

Test set batteries

17. Check the test set batteries as follows :—
Reference source battery

(1) Set the TEMPERATURE DATUM and SIGNAL/TEMP. DATUM switch to the TEMPERATURE DATUM and SIGNAL position.

(2) Turn the test selector rotary switch to BATTERY.

(3) Note the reading on METER II which should be in green zone.

Temperature signal supply battery

(1) Set the TEMPERATURE DATUM and SIGNAL/TEMP. DATUM switch to the TEMPERATURE DATUM and SIGNAL position.

(2) Turn the test selector switch to T/C RES.

(3) Turn the T/C HARNESS SELECTOR to position 'H'.

(4) Depress the T/C RESIST key to the T/C RESIST test position.

(5) Turn the temp. signal 'COARSE' control slowly clockwise.

(6) METER II should show full scale deflection when the 'COARSE' control is turned approximately three-quarters full travel.

If either of the METER II readings differ from those given above, then that particular battery is unserviceable and should be renewed.

Power supplies

18. Connect the 115V, 3-phase, 400 c/s supply to the 4-core test cable, QY2216 and check the supply as follows:—

(1) Switch on the power supply and allow five minutes to elapse before proceeding with the test.

(2) Set test selector switch to C.P.S. The 400 c/s is indicated by METER I and the PHASING lamp should be extinguished.

(3) Set the test selector switch to VOLTS. The 115V supply is indicated by METER II, which should read in the blue zone, indicating the supply to be 110—120 volts. The PHASING lamp should light.

Note . . .

If the phasing lamp does not follow this sequence, either one phase is open-circuit or the phase sequence is incorrect.

Removal of test cable QY2216

19. Disconnect, and remove the test cable QY2216 from the test circuit. Connect the 115V, 400 c/s, 3-phase supply direct to the amplifier. supply plug.

Test set preparation

20. (1) Check that the SPEED DATUM/REHEAT 3-position switch is in the centre position (OFF).

(2) Check that the TEMPERATURE DATUM and SIGNAL/TEMP. DATUM 3-position switch is in the centre position (OFF).

(3) Check that the COARSE control is fully anti-clockwise and the FINE control is in the mid-travel position (i.e. 5 clockwise turns of the 10-turn potentiometer).

(4) Set the METER II range switch to the D.C. SOLENOID 800mA position.

(5) Set the galvanometer to the FREE position and zero the pointer if necessary, using the adjusting screw.

Note . . .

Automatic cold junction compensation is provided within the QT223 test set so that no correction for ambient temperature variation is required.

Amplifier datum temperature

21. Before performing the following tests the supply to the amplifier must be switched on, ◀ and 30 minutes allowed for the unit to warm up.▶

(1) Select HIGH DATUM setting.

(2) Set the DATUM TEMPERATURE SCALE, of the test set QT223, to the approximate datum temperature for the HIGH DATUM condition. (Red pointer indicates which portion of the helix cursor line gives the exact reading.)

(3) Set the T/C HARNESS SELECTOR switch to a position appropriate to the system under test. If a non-current drawing temperature indicator is used, the SERVO POT. position must be selected.

(4) Set the test selector switch to D.C. SOL.

RESTRICTED

(5) Set the TEMPERATURE DATUM and SIGNAL/TEMP. DATUM switch to the TEMPERATURE DATUM and SIGNAL position.

(6) Set METER II range switch to the $\div 2$ position.

(7) Turn the COARSE control slowly clockwise until METER II indicates approximately 400mA. (True reading: $400 \div 2 = 200\text{mA}$.) This operation applies a signal to the thermocouple terminals and simulates the approximate datum temperature.

Note . . .

When adjusting the COARSE control, to obtain an output current reading on METER II, allowance must be made for the inherent time lag of the amplifier. If allowance is not made, by careful setting of the COARSE control overshoot of the output current will be experienced.

(8) Momentarily depress the galvanometer key to the SET-UP position and observe galvanometer. Adjust DATUM TEMPERATURE SCALE until galvanometer reads within 3 divisions of zero. If the galvanometer reading is to the left of the centre zero, the DATUM TEMPERATURE SCALE reading must be increased, and if the reading is to the right, the DATUM TEMPERATURE SCALE reading must be decreased.

Note . . .

The galvanometer key should be depressed for short period of one or two seconds during "searching" in order to prevent overload on the galvanometer should there be a large error.

(9) Switch the galvanometer key to the GALVO-IN position. Make final adjustments to METER II reading with the temp. signal FINE control, if necessary, to give a 400mA indication (true reading 200mA). Adjust DATUM TEMPERATURE SCALE until zero indication on the galvanometer is obtained.

(10) Read of the datum temperature from the DATUM TEMPERATURE

SCALE. This reading should be within the High Datum limits specified for the system. Return the galvanometer to the mid-position after taking reading.

(11) If the datum temperature is not within the specified limits, readjust the temperature trimmer on the amplifier until an acceptable figure is obtained.

(12) Repeat the test to obtain the datum temperature corresponding to the Low Datum condition. For testing at Low Datum of 351°C. refer to Sect. 10, Chapt.1 of this publication. Return datum selector to HIGH DATUM.

Gain

22. (1) Decrease the temp. signal FINE control until the output on METER II indicates 100mA (true reading 50mA). Measure the temperature indicated on the DATUM TEMPERATURE SCALE with zero indication of the galvanometer. Return galvanometer key to mid-position after taking readings.

(2) Increase the temp. signal FINE control until the output on METER II indicates 700mA (true reading 350mA). Note the temperature indicated on the DATUM TEMPERATURE SCALE, with zero indication of the galvanometer as in the previous sub-para.

(3) The temperature difference indicated on the DATUM TEMPERATURE SCALE for sub-para. (1) and sub-para. (2) should be 6 to 10 deg.C.

(4) Return galvanometer key to the the centre (OFF) position.

Time response

23. Ensure datum selector is set to the HIGH DATUM position and proceed as follows:—

(1) Adjust the temp. signal controls to give 350mA (true reading) on METER II.

(2) Switch in Step Circuit (fig. 4) and adjust Step Circuit control potentiometers to reduce METER II reading to 50mA (true reading).

RESTRICTED

(3) Switch out Step Circuit and, using stop watch, Check the time taken for the current, indicated on METER II to rise from 50 to 250mA. Ensure that the current finally steadies at 350 ± 20 mA.

(4) Switch in Step Circuit again, and check the time taken for the current to fall from 350 to 150mA.

(5) Allow the current to fall to 50mA, and repeat the timing operations in sub-para.

(3) and (4). The average time for these four measurements should be between 15 and 30 seconds. ▶

Insulation resistance test

24. Measure the insulation resistance between the points listed below, the readings obtained should not be less than 5 megohms.

(1) Thermocouple +ve terminal and chassis.

(2) Thermocouple +ve terminal and pole A of the output plug.

(3) Thermocouple +ve terminal and pole A to the supply plug.

(4) Pole A of the output plug and chassis.

(5) Pole A of the output plug and pole A of the supply plug.

(6) Pole A of the supply plug and chassis.

RESTRICTED

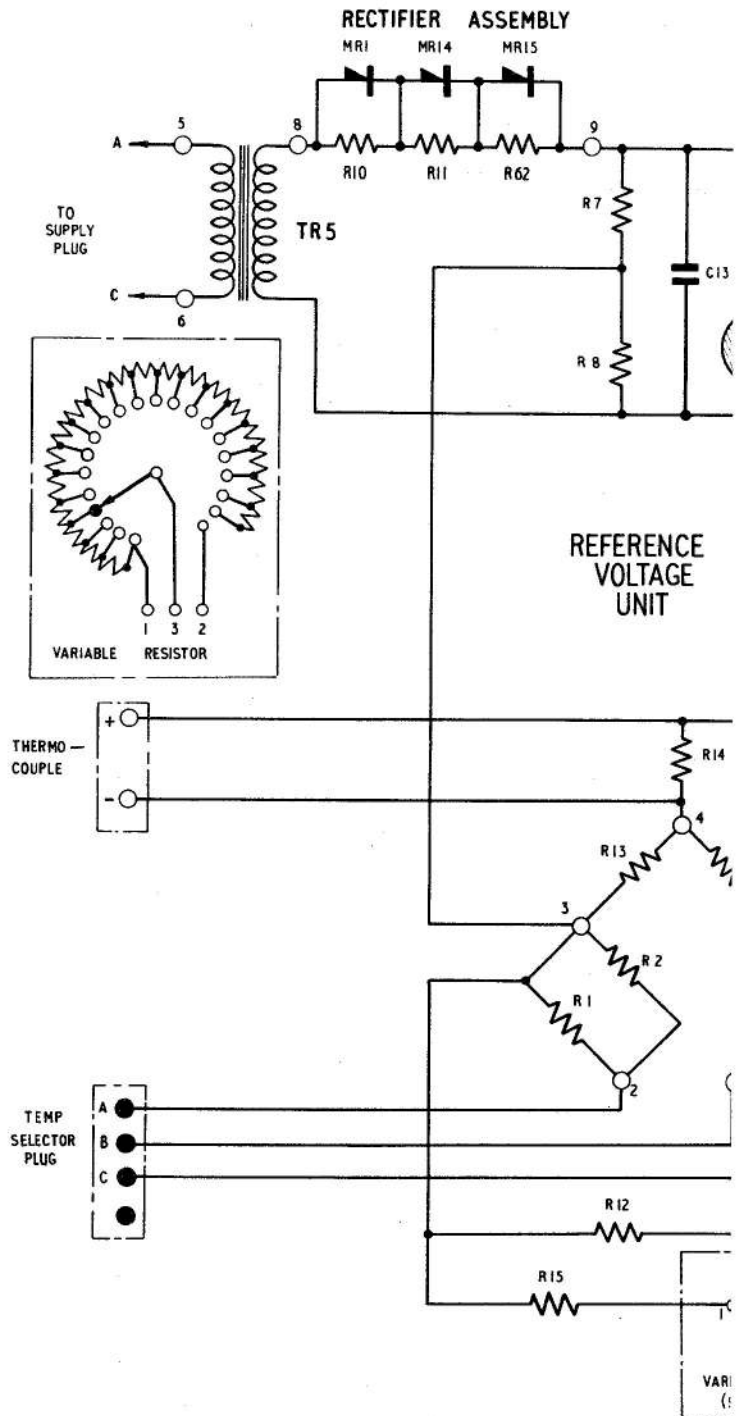
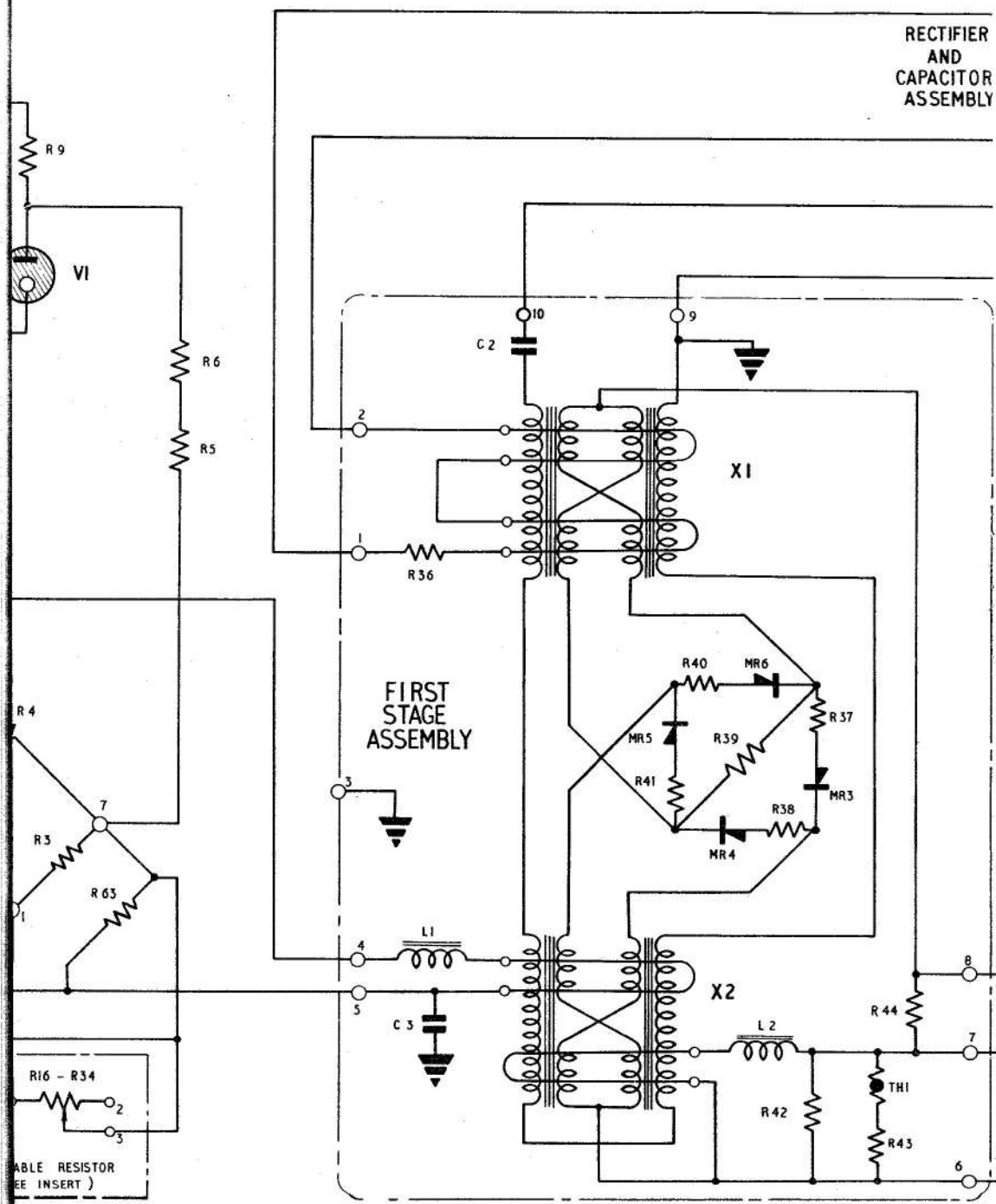

Fig.5

RECTIFIER
AND
CAPACITOR
ASSEMBLY



FIRST
STAGE
ASSEMBLY

R16 - R34
(SEE RESISTOR
VALUE INSERT)

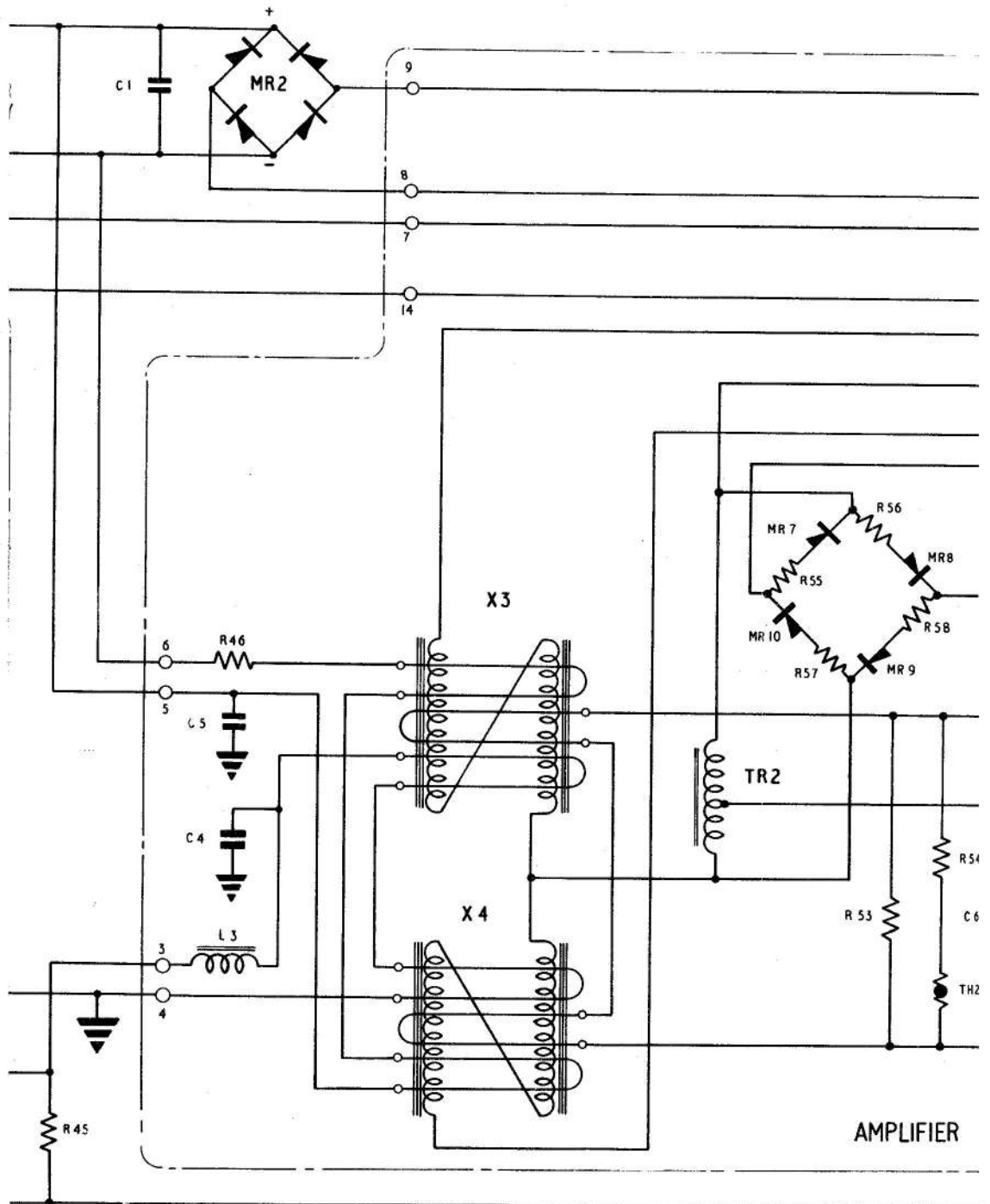

Amplifier EC I/6 circuit diagram

R E S T R I C T E D

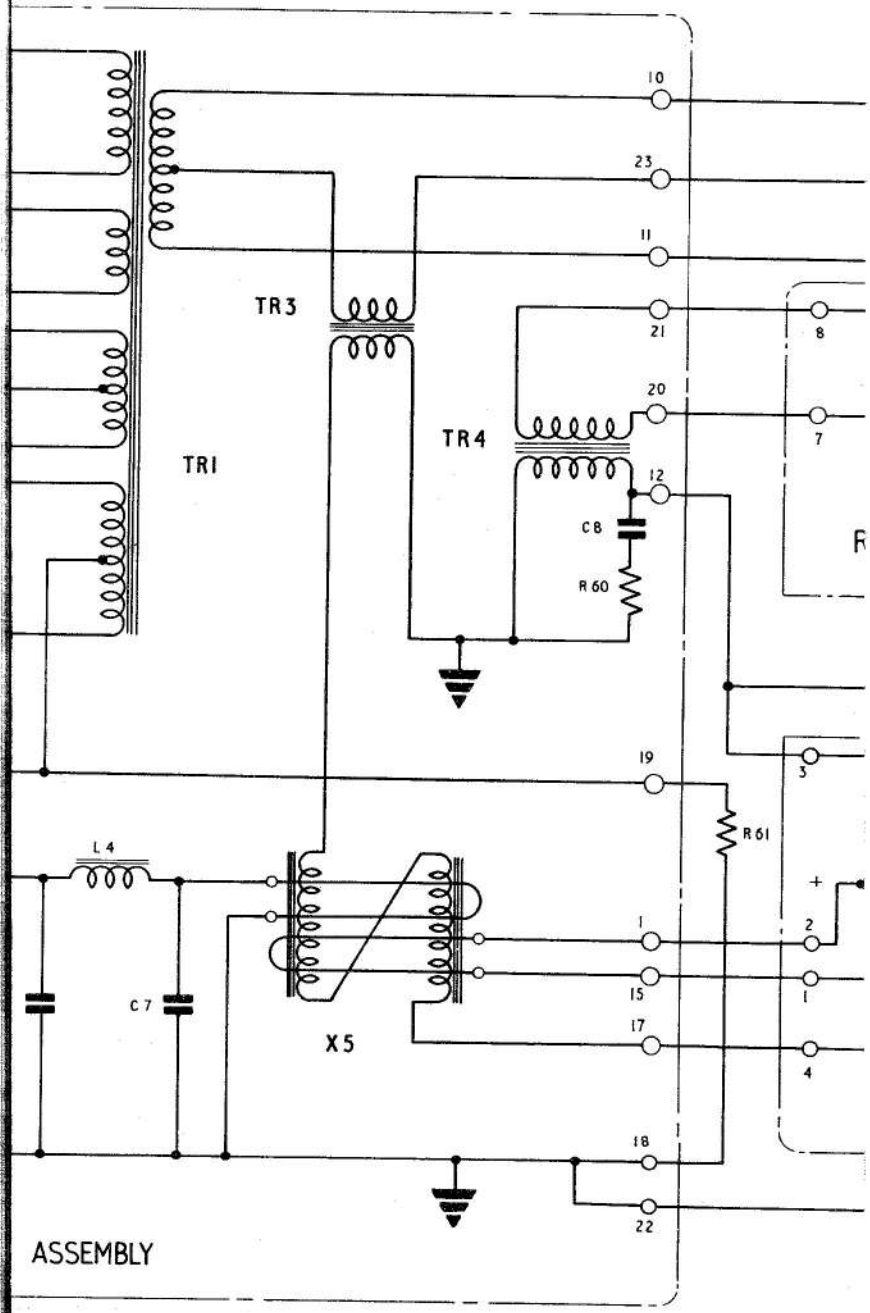

ASSEMBLY

This file was downloaded
from the RTFM Library.
Link:www.scottbouch.com/rtfm

Please see site for usage terms,
and more aircraft documents.

