

*Cancelled  
new AP 113F-0404-1*

**Chapter 10**

**AMPLIFIER, ULTRA, TYPE A601/1**

**LIST OF CONTENTS**

	Para.		Para.
<b>Introduction</b> ... ..	1	<b>Precautions</b> ... ..	51
<b>Description</b>		<b>Preparations</b> ... ..	52
<b>General</b> ... ..	6	<b>Connections</b> ... ..	53
<b>Principles of operation</b> ... ..	9	<b>Thermocouple harness resistance</b>	54
<b>Circuit description</b>	14	<b>Preparing the control unit and the</b>	
<b>Temperature Channel</b> ... ..	15	<b>motor unit</b> ... ..	55
<b>Speed channel</b> ... ..	20	<b>Temperature datum test</b> ... ..	56
<b>Low datum circuit</b> ... ..	23	<b>Temperature gain test</b> ... ..	57
<b>Stage 3</b> ... ..	24	<b>Standing current test</b> ... ..	58
<b>Output stage</b> ... ..	25	<b>R.P.M. datum test</b> ... ..	59
<b>Feedback circuits</b> ... ..	27	<b>R .P.M. gain test</b> ... ..	60
<b>Bias circuits</b> ... ..	36	<b>Low r.p.m. datum test</b> ... ..	61
<b>Datum selection and trim</b> ... ..	42	<b>Disconnecting the test equipment</b> ... ..	62
<b>Safety resistor</b> ... ..	45	<b>Aircraft test—ground running con-</b>	
<b>Test facilities</b> ... ..	46	<b>ditions</b> ... ..	63
<b>Testing</b>		<b>Fault finding</b>	
<b>Bench tests</b> ... ..	49	<b>Measurements</b> ... ..	64
<b>Aircraft tests-static conditions</b> ... ..	50	<b>Insulation resistance</b> ... ..	66

**LIST OF TABLES**

	Table
<i>Voltage and resistance measurments</i>	1
<i>Resistance values for continuity tests</i>	2

**LIST OF ILLUSTRATIONS**

	Fig.		Fig.
<i>Amplifier, Ultra, Type A601/1</i> ...	1	<i>Amplifier, Ultra, Type A601/1 block</i>	
<i>Temperature datum selector bobbin</i>	2	<i>schematic</i> ... ..	5
<i>Amplifier, Ultra, Type A601/1—top</i>		<i>Schematic diagram of Amplifier</i>	
<i>cover removed</i> ... ..	3	<i>circuits</i> ... ..	6
<i>Amplifier, Ultra, Type A601/1—</i>		<i>Aircraft test connections</i> ... ..	7
<i>bottom cover removed</i> ... ..	4	<i>Amplifier, Ultra, Type A601/1—</i>	
		<i>current</i> ... ..	8

**RESTRICTED**

## LEADING PARTICULARS

Amplifier, Ultra, Type A601/1	...	...	...	...	Ref. No. 5CZ/6588
Output at datum speed or temperature	...	...	...	...	225 mA d.c.
Power supplies	...	...	...	115V, 400 c/s; 1-ph 28V d.c.	
Temperature datum	...	...	...	dependent on the type of datum selector fitted.	
Speed datum	...	...	...	...	4428 r.p.m.
Temperature datum trim range	...	...	...	approx. 35°C (using RV3)	
Speed datum trim range	...	...	...	185 r.p.m. (using RV4)	
Output with open circuit inputs	...	...	...	...	approx 85 mA.
Dimensions	...	...	...	11 in. × 4 $\frac{1}{8}$ in. × 6 $\frac{5}{8}$ in.	
Weight	...	...	...	...	12 $\frac{1}{2}$ lb.

The following temperature datum selector units, Types ZR76 and ZR86 are designed for use with amplifier, Ultra, Type A601/1.

Type	Ref. No.	Temperature datums (°C)		
		Cruise	Climb	Take-off
ZR76/AE	5CZ/6011	595	625	655
ZR76/AP	5CZ/6165	615	645	675
ZR76/AR	5CZ/6166	600	615	660
ZR86/BL	5CZ/6855	610	635	670
ZR86/BV	5CZ/7391	630	665	690

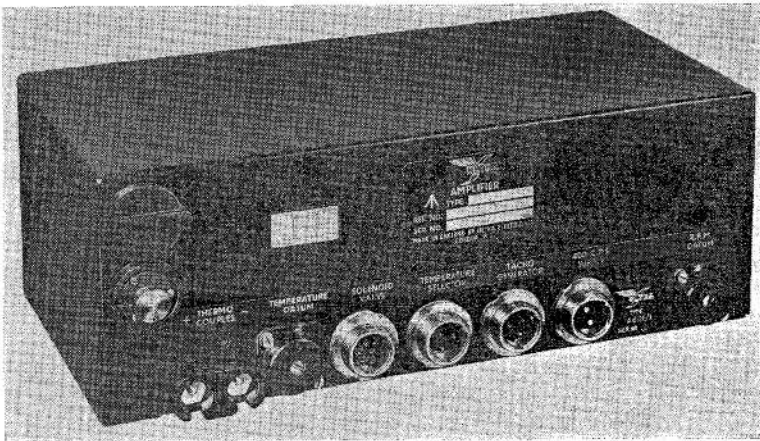

Fig. 1. Amplifier, Ultra, Type A601/1

**RESTRICTED**

## Introduction

1. Amplifier, Ultra, Type A601/1 (fig. 1) is a magnetic amplifier unit designed to effect limitation of the low pressure compressor speed, and jet-pipe temperature of a gas-turbine engine. Datum selector units (fig 2) provide a range of temperature datums according to flight requirements; the speed datum is fixed.

2. Sensing elements consist of a tachogenerator coupled to the low pressure compressor shaft, and thermocouples attached to the engine jet-pipe. The signals from these sensing elements are fed simultaneously to the amplifier where they are compared with the preset datums. If either input exceeds its datum the amplifier produces a d.c. output current which is used to energise a solenoid operated valve in the engine fuel system, thus reducing the flow of fuel until the speed, or temperature, falls below datum. The control system operates only to prevent the datums being exceeded; no control is exercised as a result of below-datum signals. If both input signals exceed their datums, the output contains a component proportional to the error present in each channel. The extent of fuel limitation provided by the control system is about 50% of the total fuel flow so the system is, therefore, in the category of a trim control.

3. During steady state conditions, for instance, whilst the aircraft is cruising, the amplifier response is slow, 8-10 seconds being required to cover the full output current range. Minor transients of speed, and temperature arising from random variations in fuel flow, do not, therefore, produce any limiting. However, the response rate is proportional to the rate of change of the input signals, rapid changes of input resulting in response rates of less than 100 m./sec. Thus rapid increases in speed, or temperature, are anticipated, and overshoot of the control system is largely eliminated.

4. The speed datum is set during manufacture but the temperature datum may be altered over a wide range by the use of a suitable datum selector unit. The selector is plugged into the front panel of the amplifier and is used in conjunction with temperature selector relays within the amplifier. The relays are controlled by a control switch operated by the pilot or flight

engineer. The datum selector unit allows a choice of three datums, corresponding to take-off, climb and cruise conditions. A.P.4343K, Vol. 1, Sect. 6, Chap. 1 describes the datum selectors used in amplifier, Type A601/1.

5. Further information about the general principles of the control system will be found in A.P.4343, Vol. 1, Sect. 13, Chap. 4, dealing with jet pipe temperature control, and A.P.4343, Vol. 1, Sect. 5, Chap. 1, dealing with magnetic amplifiers.

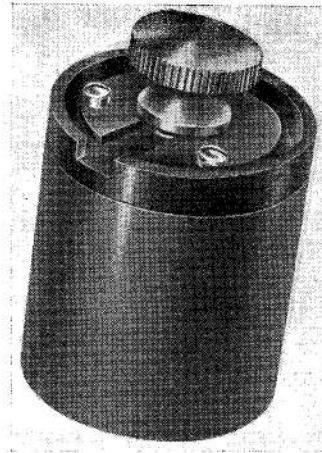

Fig. 2. Temperature datum selector bobbin

## DESCRIPTION

6. The components of the amplifier are mounted on the top, and underside, of a chassis, which is enclosed by a top cover, and a baseplate. Certain parts of the amplifier, namely the magnetic amplifying stages, the discriminator, the rectifier, the power transformer, and the capacitor unit, are housed in sealed canisters. Access to the electrical connections to these canisters is obtained from the underside of the chassis (fig. 4). Fig. 3 shows the layout of the canisters, and selector relays. It will be seen that two sockets are provided for the insertion of selector bobbins. In current applications of the amplifier, the upper socket is unused, and a blanking cap is fitted in the top cover over this socket.

**RESTRICTED**

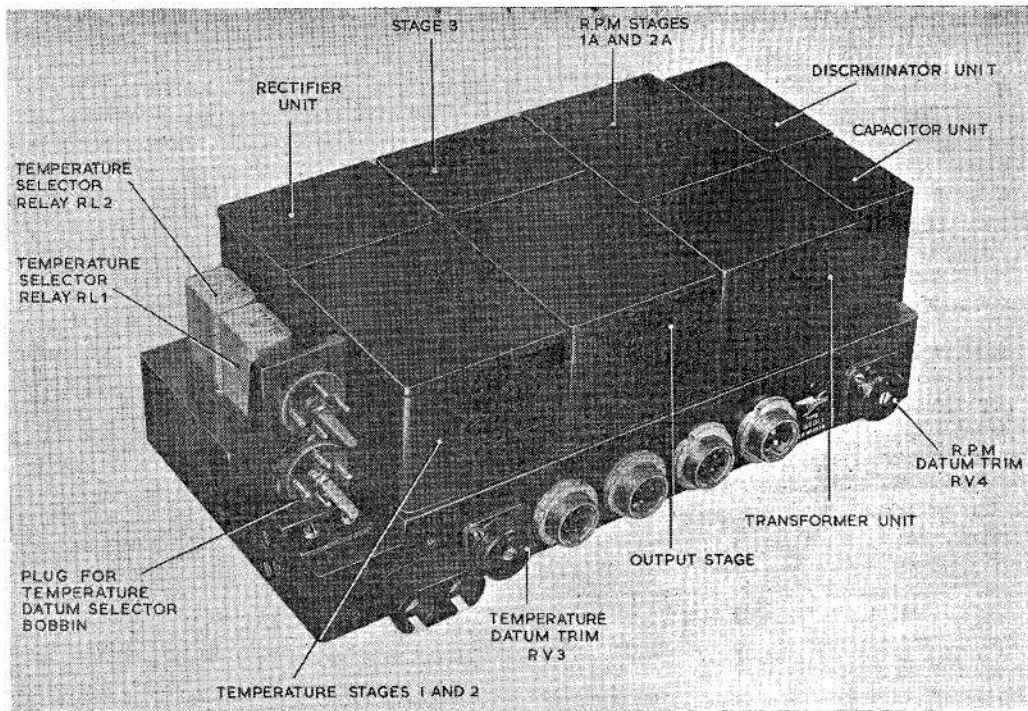
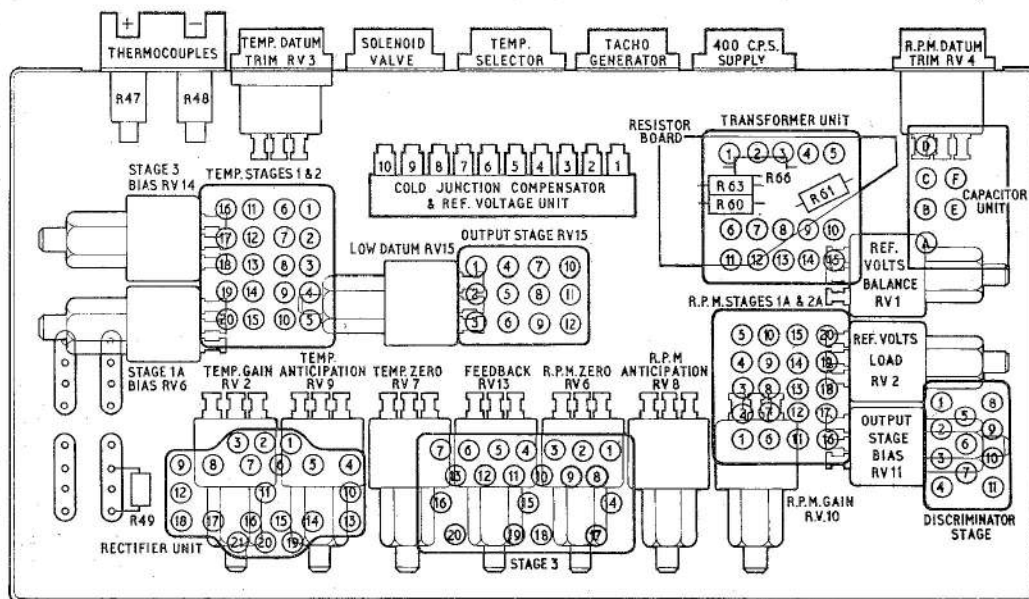

Fig. 3. Amplifier, Ultra, Type A601/1—top cover removed



SCRAP VIEW OF POTENTIOMETER TERMINALS

Fig. 4. Amplifier, Ultra, Type A601/1—bottom corner removed

**RESTRICTED**

7. Electrical connections to the amplifier are as follows:—

- (1) A two-pole plug for the 400 c/s supply.
- (2) A three-pole plug for the tachogenerator signal.
- (3) A six-pole socket for the output, and test connections.
- (4) A three-pole plug for the 28V d.c. supply to the temperature selector relays.
- (5) A two-pole terminal block for the connections to the aircraft engine thermocouple harness.

8. Four,  $\frac{1}{4}$  in. UNF inserts, located in the base of the amplifier are used for securing the amplifier to its mounting in the aircraft. Instructions concerning the depth of entry of the securing bolts are provided on the base plate of the amplifier.

#### PRINCIPLES OF OPERATION

9. A block schematic diagram (fig. 5) illustrates the main circuit features of the amplifier Type A601/1.

10. The power supplies for the individual stages are derived from the transformer unit, fed from the 115V, 400 c/s aircraft supply.

11. The temperature input signal is derived from chromel-alumel thermocouples located in the engine jet-pipe. This signal is applied to the reference volts, and cold junction compensation bridge, via the datum selector unit. The cold junction compensation bridge corrects the input signal to offset errors caused by variations of ambient temperature at the cold junction formed by the thermocouple terminals of the amplifier. The compensated voltage is then compared with a preset datum voltage derived from a stabilised reference source. The difference between the input, and datum voltages, is the temperature error voltage, and forms the input to temperature amplifier stage 1. Further amplification follows in stage 2, and the temperature signal is then combined with the amplified speed error signal in stage 3. The output of stage 3 is fed to the final amplifying stage, stage 4. The output of stage 4 is rectified, and fed, via the output plug of the amplifier, to the fuel control valve solenoid.

12. The engine speed signal is derived from an a.c. tachogenerator coupled to the low pressure compressor shaft. The frequency of the signal is directly proportional to engine speed. The signal is applied to a frequency discriminator bridge to produce a d.c. voltage the level of which depends on engine speed. A speed datum voltage is derived from the resistive arm of the bridge, and the d.c. speed signal is compared with this datum voltage, resulting in an error voltage which is applied to the input of speed signal amplifier stage 1A. Further amplification follows in stage 2A, the output of which is mixed with the output of the temperature channel in stage 3.

13. A number of feedback loops (fig. 6) provide control of gain, response, and stability, and various bias supplies maintain the magnetic amplifiers at their optimum points.

#### CIRCUIT DESCRIPTION

14. A circuit diagram of the amplifier is illustrated in fig. 8.

##### Temperature channel

15. A 72V, 400 c/s supply from winding W6 of transformer T1 is rectified by MR12 and MR13, smoothed by R1 and C1 and applied across the voltage stabilising bridge R2, R3, RV1 and MR11. The output voltage of this bridge, at seals 14 and 20 of stage 3, is stabilised against fluctuations of the 400 c/s power supply by the Zener reverse voltage characteristic of the silicon diode MR11. Adjustment of the stabilised output is effected by RV1 and RV2, and the voltage is fed to the cold junction compensation (C.J.C.) unit. Potentiometers RV1 and RV2 are preset, and locked, during the initial setting up of the amplifier.

16. The thermocouple output is applied to the C.J.C. unit via selector relays RL1 and RL2, the selector bobbin, the control winding of temperature stage 1, and the datum trim potentiometer, RV3. Operation of a selector relay RL1 or RL2 adjusts the reference voltage, and therefore enables a temperature datum to be selected that is appropriate to a specified flight condition, i.e. TAKE-OFF, CRUISE or CLIMB. The temperature datums, corresponding to these

**RESTRICTED**

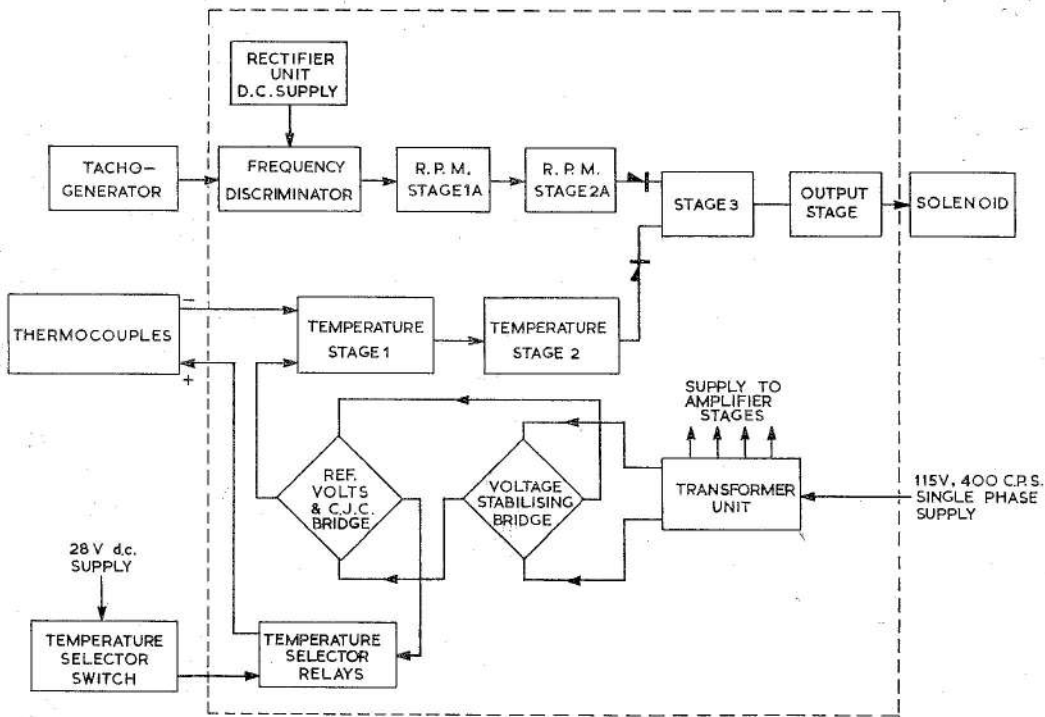

Fig 5. Amplifier, Ultra, Type A601/1—block schematic

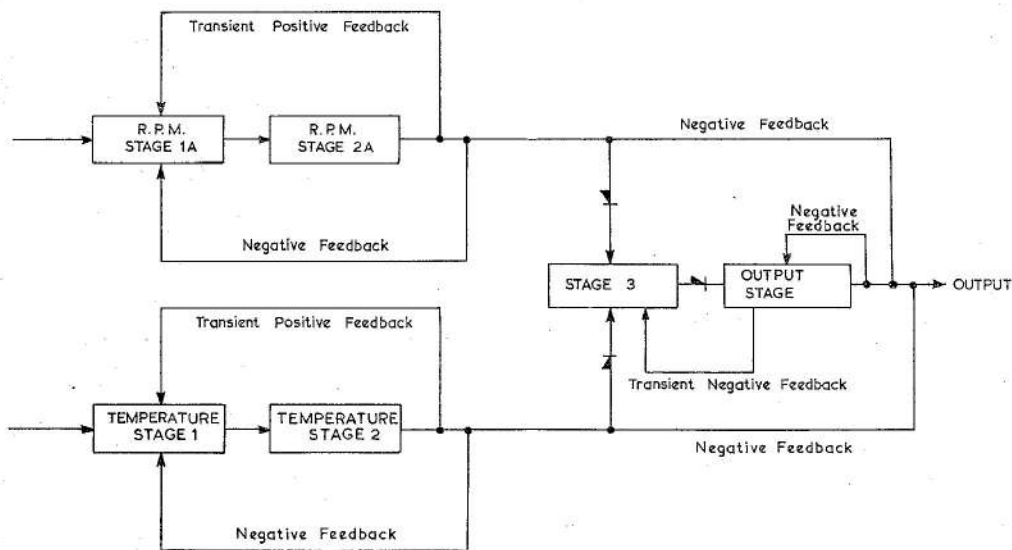

Fig. 6. Schematic diagram of amplifier feedback circuits

**RESTRICTED**

flight conditions, are specified by the engine manufacturer. Alternative combinations of three temperature datums, arranged to suit individual engine characteristics, can be obtained by using alternative types of plug-in selector bobbin as listed previously.

**17.** The voltage from the thermocouples opposes the reference voltage at the reference voltage, and C.J.C. bridge. Any voltage difference results in a current (error signal) in the control winding of temperature stage 1. At the selected datum temperature, the reference, and thermocouple voltages are balanced, and the error signal is approximately zero. Potentiometer RV3 is used as a final trim to obtain this balanced condition.

**18.** To limit the jet-pipe temperature to the specified datum it is necessary to compensate for thermocouple voltage changes which are due to changes in the cold junction ambient temperature. Compensation is effected by the inclusion of a copper resistance coil, located adjacent to the thermocouple input terminals, in one arm of the C.J.C. bridge. The resistance of the copper coil varies as the ambient temperature varies, and therefore modifies the reference voltage level of the C.J.C. bridge. The subsequent change in C.J.C. bridge reference voltage is equal, and opposite, to the voltage change, due to the change in cold junction ambient temperature, at the thermocouple input terminals. The amplifier temperature channel is therefore referred to a thermocouple voltage which is dependent solely on the hot junction temperature.

**19.** The temperature error signal is amplified by stages 1 and 2. Each of these amplifying stages comprises a pair of auto-self-excited transducers operating in push-pull and therefore responds to above datum (positive), or below (negative), signals. The output from stage 2, with the addition of feedback from the output stage (via R40), is applied to a control winding in stage 3, via rectifier MR27 which eliminates any negative temperature signals from temperature stage 2. MR27 ensures, therefore, that only those signals resulting from an above-datum temperature are passed to stage 3.

#### Speed channel

**20.** The frequency of the a.c. input from the tachogenerator is directly proportional to

compressor speed. Frequency discrimination of this a.c. signal is performed by a transistorised version of the Maxwell bridge discriminator.

**21.** The tachogenerator signal is applied to the common base-emitter circuit of transistors VT1 (n-p-n) and VT2 (p-n-p) connected so that the a.c. signal triggers the transistors in alternate half-cycles. Transient surge protection for the transistors is provided by the limiting resistors R64 and R65 and Zener diodes MR46 and MR47. During the positive half of the a.c. cycle, VT1 conducts and charges capacitor C3 via R53. During the negative half-cycle, VT2 conducts thus discharging C3 via R52. Each resistor, R52 and R53, will therefore carry a d.c. current the average value of which depends on: applied voltage x capacity x switching frequency.

**22.** This current results in a mean potential, at the junction of R52 and VT2, which is directly proportional to engine speed. The potential is compared with an ambient compensated reference potential from the resistive arm of the bridge, namely R61, R17, RV16, RV4, R55 and R54 to the lower end of R53. The bridge will be in balance when the mean potential at the junction of R52 and VT2 equals the potential of the resistive arm. Unbalance of the bridge, which occurs when the compressor speed departs from the selected datum, will result in a current flow through the control winding of stage 1A via inductor L1. The output of stage 1A receives further amplification in stage 2A. Each stage consists of a pair of auto-self-excited transducers, operating in push-pull. The rectified output of stage 2A is applied to a control winding in stage 3, via rectifier MR26 which eliminates negative speed signals from stage 2A. MR26 ensures, therefore, that only those signals resulting from an above datum speed are passed to stage 3.

#### Low datum circuit

**23.** A low c.r.p.m. datum test circuit is provided by the resistor network R15, R60, R63, R44, R43 and RV15 and windings 3 and 4 of stage 1A. This circuit is connected across R5 in the temperature reference source, thus providing a stable, temperature compensated potential in the series-parallel network of R15, R60, R63, R44 and R43 and this poten-

**RESTRICTED**

tial produces a current flow through winding 3 of stage 1A to provide positive bias. When a short circuit is connected across pins E and F of the SOLENOID VALVE socket, a current which is preset by RV15 flows in windings 3 and 4 increasing the bias ampere turns, thereby causing the stage to reach a balanced state with a lower speed input signal. This arrangement enables the speed control system to be tested over its full range without the necessity to run the engine at full speed.

### Stage 3

24. The speed and temperature signals are applied to the control windings of the auto-self-excited transducer in stage 3 and are therefore combined and amplified in this stage. The output of stage 3 is fed via rectifier MR32, to the control winding of the output stage. Stage 3 is biased negatively and, in the absence of positive input signals, the output would be negative, thus biasing the output stage well into the negative state, and any subsequent positive signal would have to drive the output stage from this condition. Inclusion of the rectifier MR32 eliminates the negative output from stage 3 and thereby ensures that the output stage level does not fall below that resulting from the standing current. A quick response to signals above datum is thereby maintained.

### Output stage

25. The output stage consists of a single-ended transducer, the output of which is bridge-rectified by MR35 to MR38 and applied to the solenoid-controlled valve in the engine fuel system. If either the speed or temperature signal exceed its selected datum, an output signal is applied to the fuel valve to provide the required corrective action. If both signals exceed their respective datum values, the output signal contains a component proportional to the error present in each channel.

26. Resistor R14 located in the C.J.C. unit, is connected in series with the load circuit and provides a test voltage at terminals C and D of the output (SOLENOID VALVE) plug. Connections from the speed channel to the pins E and F of the output plug provide a means of obtaining a low r.p.m. datum for test purposes by short circuiting these pins.

### Feedback circuits

27. There are seven main feedback loops.

These provide stability and control of the gain and time response. A block schematic diagram (fig. 6) illustrates the feedback circuits of the amplifier.

28. A positive feedback voltage from the output of r.p.m. stage 2A is developed across RV8, connected between terminals 4 and 5. The required proportion of this voltage is applied across winding 6 of r.p.m. stage 1A. Capacitors C7 and C8 and resistor R24 are connected in series with this winding; the circuit functions, therefore, under transient conditions, i.e. is responds to changes in r.p.m. in the sense that anticipates further changes in the same direction. This feedback is inoperative during steady state conditions and the amount of feedback applied depends on the rate of change of the error.

29. A negative feedback voltage from the output of r.p.m. stage 2A is developed across R28, and is applied to winding 5 of stage 1A in series with potentiometer RV10. The potentiometer is connected to r.p.m. stage 2A at terminals 5 and 8, and constitutes the gain control for the speed channel.

30. A temperature change anticipation circuit is provided by the voltage developed across RV9, and applied across winding 3 of temperature stage 1. Capacitors C9 and C10, and a resistor R33 are connected in series with this winding. The circuit functions, therefore, under transient conditions in the same way as the r.p.m. anticipation circuit.

31. A negative feedback voltage is developed across R37 by the output of stage 2, and is applied to winding 4 of temperature stage 1 to provide control of the temperature gain. Potentiometer RV12 is connected in series with this winding.

32. A negative feedback voltage is developed by the output of stage 4, across R40 (stage 4, terminals 2 and 12) and, together with the temperature error signal, is applied to winding 4 (temperature control winding) of stage 3. The purpose of this feedback loop is to provide stability in the amplifier during operation of the temperature channel.

33. A negative feedback voltage is developed across potentiometer RV13 by the output of stage 4, and together with the r.p.m. error signal, is applied to winding 3

**RESTRICTED**

(r.p.m. control winding) of stage 3. The purpose of this feedback loop is to provide stability in the amplifier during operation of the r.p.m. channel.

**34.** A transient negative feedback loop from the output stage to stage 3 consists of the voltage induced in windings 2 and 4 of the output stage (terminals 10 and 11), applied to winding 2 of stage 3 (terminal 4 and 5) in series with the primary of transformer T2 located in the rectifier unit. If the r.p.m. error signal is steady, or zero, there is no current in the transformer secondary, and hence no e.m.f. is induced in the primary which acts simply as a fixed impedance. If temperature changes now occur, the transient negative feedback is fully effective so that response to temperature changes is slow. If, however, a transient r.p.m. error occurs, and current flows in the transformer secondary, the e.m.f. induced in the primary opposes the transient negative feedback. The negative feedback is now ineffective, and very fast response to the r.p.m. error change is ensured.

**35.** Negative feedback for stage 4 is provided by a single turn winding, winding 6, which carries the output current.

#### Bias circuits

**36.** The r.p.m. stage 1A is biased negatively by winding 7 which carries the current in the mixing resistors R21 and R22. The winding is shunted by the variable resistor RV6, by means of which stages 1 and 2A are balanced.

**37.** The r.p.m. stage 2A is negatively biased by means of a positive feedback of the current in the mixing resistors R25 and R26, to winding 5. The cross-bias technique is used, i.e. the mixing current in the X-transducer is used for the Y-transducer bias, and vice-versa.

**38.** The temperature stage 1 is negatively biased, winding 5 carrying the current from the mixing resistors R30 and R31. The winding is shunted by the potentiometer RV7 which is adjusted to obtain balance of stages 1 and 2.

**39.** In temperature stage 2 negative bias is effected by winding 5 which carries the current from mixing resistors R34 and R35.

**40.** Stage 3 is negatively biased by winding 6 which carries the current in resistors R38 and R39. In addition, a preset negative bias is provided by winding 5, the current being derived from rectifiers MR39 and MR40 in temperature stage 2; the amplitude is adjusted by RV14. This bias controls the rate of fall of solenoid current when input signals, exceeding the datum levels, are removed

**41.** In the output stage, preset negative bias is provided by winding 5 which carries the current derived from MR39 and MR40. The bias level is controlled by the value of the fixed shunt resistor R41, and the variable resistor RV11. This bias is adjusted to give the required setting of standing output current. R41 controls the level of the bias to offset the effects of changes of ambient temperature.

#### Datum selection and trim

**42.** The speed datum is set initially, by RV16, and fine control of the datum level is provided by RV4, which is the front panel control marked R.P.M. DATUM. RV4 has a range of approximately 4.5% in steps of 0.3%.

**43.** The required temperature datum, corresponding to specified flight conditions, is selected by operation of the selector relays, RL1 and RL2.

(1) With RL1, and RL2 both de-energized, the selected temperature datum corresponds to the TAKE-OFF condition.

(2) With RL1 de-energized, and RL2 energized, the selected temperature datum corresponds to the CLIMB condition.

(3) With RL1 energized, and relay RL2 de-energized, the selected temperature datum corresponds to the CRUISE condition.

Operation of the selector relays adjusts the balance of the reference voltage, and C.J.C. bridge, and therefore modifies the value of the reference voltage. When the engine jet-pipe is at the selected temperature datum, the reference voltage is equal to the thermocouple signal, and the input to temperature stage 1 is approximately zero. Potentiometer RV3 is the trim control for the temperature datum, and has a range

**RESTRICTED**

of approximately 35°C, effective on all datum levels; it is a front panel control and is labelled TEMPERATURE DATUM. The selected temperature datums, corresponding to the above flight conditions, are dependent on the type of selector bobbin that is inserted in the magnetic amplifier unit. Temperature datums to suit individual engine characteristics can be obtained by using the appropriate type of selector bobbin.

44. Both trim controls, RV3 and RV4, are 'click' potentiometers operating in fifteen steps lettered A to R with positions I and O omitted.

#### Safety resistor

45. A 4-7k $\Omega$  resistor (R29), located in temperature stages 1 and 2, ensures that a negative signal is passed to the amplifier in the event of an open-circuit fault on the thermocouples.

#### Test facilities

46. Provision is made for monitoring the output current of the amplifier, and also for artificially lowering the speed datum to a level suitable for ground running tests on an aircraft mounted amplifier.

47. Resistor R14, in the C.J.C unit, is in series with the output current flowing through pole A of the output socket. The ends of this resistor are also connected to poles C and D of the same socket. The voltage developed across the resistor, can, therefore, be measured whilst the amplifier is in operation and this voltage gives a direct indication of the output current.

48. A low speed datum facility is provided, which allows the amplifier to be tested to its full speed datum with the aircraft engine running at idling speed. This test facility is described in para. 23.

## TESTING

#### Bench tests

49. Instructions for bench testing the amplifier, Type A601/1 are given in Appendix A of this Air Publication.

#### Aircraft tests—static conditions

50. The following tests are performed on an installed amplifier, and represent a

check on the aircraft wiring, power supply, speed and temperature indicators, and jet-pipe thermocouples, as well as on the amplifier itself. For these tests, the jet-pipe thermocouple signal is simulated by a test voltage injected into the system at the thermocouple commoning points. The test speed signal is injected at the engine end of the tachogenerator cable. The amplifier output load is formed by the fuel bleed valve solenoid on the engine.

#### Precautions

51. To avoid possible damage to the Test Set QT223 the following precautions must be observed.

(1) Before switching on the supply, and unless the testing instructions state otherwise, the REHEAT/SPEED DATUM switch must be in the OFF position.

(2) When adjusting the DATUM TEMPERATURE scale, during temperature signal measurements, avoid running the scale control knob hard on to its limit stops.

#### Preparations

52. Before connecting the test equipment to the amplifier, Type A601/1, the following procedure must be carried out.

(1) Set the TEMP. DATUM/OFF/TEMPERATURE DATUM & SIGNAL switch (QT223) to TEMPERATURE DATUM and SIGNAL.

(2) Set the TEST SELECTOR switch (QT223) to BATTERY and check that the needle of METER II (QT223) is in the green zone. If not, renew the reference source battery in QT223. (Mallory Type SKB 544 Ref. No. 5J/3465).

(3) Turn the TEST SELECTOR switch (QT223) to T/C RES.

(4) Turn the HARNESS SELECTOR switch (QT223) to position G.

(5) Depress the T/C RESIST TEST key switch (QT223) to the T/C RESIST TEST position.

(6) Rotate the TEMP. SIGNAL COARSE control (QT223) slowly clockwise.

(7) METER II (QT223) should indicate full scale deflection before full travel of the COARSE control. If it does not, renew the temperature

**RESTRICTED**

signal source battery in QT223. (Mallory Type SKB 536 Ref. No. 5J/3464).

(8) Set the TEMP. DATUM/OFF/TEMPERATURE DATUM AND SIGNAL switch (QT223) to OFF.

(9) Set the TEMP. SIGNAL COARSE and FINE controls (QT223) fully counter-clockwise.

(10) Set METER II switch (QT223) to D.C. SOLENOID 800 mA.

(11) Set the TEST POSITION switch (QC2A80) to AIRCRAFT.

(12) Set the SPEED SIGNAL controls (QC2A80) fully counter-clockwise.

(13) Set the SPEED DATUM scale (QC2A80) to 100%.

(14) Set the SELECT METER TEST switch (QC2A80) to BATT.

(15) Set the SELECT SPEED MEASUREMENT RANGE switch (QC2A80) to position 1.

(16) Check that the needle on METER I (QC2A80) is in the green zone. If it is not, renew the battery in QC2A80 (Mallory Type SKB 544 Ref. No. 5J/3465). Return the SELECT SPEED MEASUREMENT RANGE switch (QC2A80) to OFF.

(17) Check that the tachogenerator in the motor unit (QM2A80) is of the same type as that fitted in the aircraft.

(18) During tests of the r.p.m. channel of the amplifier, avoid running the motor in QM2A80 at non-synchronous speeds for prolonged periods.

### Connections

53. Connect the test equipment, and power supplies to the aircraft cabling as shown in fig. 7.

### Thermocouple harness resistance

54. This test is effected by comparing the resistance of the aircraft thermocouple harness with that of a standard resistor in the test set, Type QT223.

(1) Set the T/C HARNESS SELECTOR switch (QT223) to the position appropriate to the thermocouple cluster under test. The standard resistors associated with the switch positions are given below.

Switch position	Resistance (ohms)
A	1.5
B	1.0
C	0.8
D	0.5
E	0.34
F	0.3
G	0.25
H	0.2
J	SPARE

Harness resistance outside the range given overleaf may be measured by using a separate plug-in resistor unit which is brought into circuit when the T/C HARNESS SELECTOR is set to position J.

(2) Set the TEST SELECTOR switch (QT223) to T/C RES.

(3) Set the TEMP. DATUM/OFF/TEMPERATURE DATUM AND SIGNAL switch (QT223) to TEMPERATURE DATUM AND SIGNAL.

(4) Rotate the TEMP. SIGNAL COARSE control (QT223) clockwise until the needle of METER II (QT223) coincides with the red scale mark.

(5) Depress the T/C RESIST. TEST switch (QT223) to T/C RESIST TEST. The needle of METER II (QT223) should not deviate from the red line by more than 3 scale divisions. If it does, a thermocouple circuit fault is indicated. This fault should be found and corrected before proceeding further.

(6) Rotate the TEMP. SIGNAL COARSE control (QT223) fully counter-clockwise and set the TEMP. DATUM / OFF / TEMPERATURE DATUM AND SIGNAL switch (QT223) to OFF.

### Preparing the control unit and the motor unit

55. (1) Set the TORQUE switch (QM2A80) to HIGH.

(2) Set ROTATION switch (QM2A80) to A.C.W.

(3) Set A/C TESTS switch (QM2A80) to STATIC.

**RESTRICTED**

(4) Set TACHO GENERATOR LOAD switch (QC2A80) to NO LOAD and set the DATUM SELECTOR switch (QC2A80) to HIGH.

(5) Set the SELECT SPEED MEASUREMENT RANGE switch (QC2A80) to position 1.

(6) Set the 28V D.C. SUPPLY switch (QC2A80) to ON, and check that the supply lamp is lit.

(7) If the supply lamp does not light, check the polarity of the d.c. supply.

(8) Set the SELECT METER TEST switch (QC2A80) to  $\emptyset 1$ , and check that meter I (QC2A80) indicates an output voltage from the tachogenerator.

(9) Rotate the SPEED SIGNAL COARSE control (QC2A80) slowly clockwise until the motor reaches synchronous speed. This is indicated by a slowly increasing reading on METER I.

(10) Continue to rotate the SPEED SIGNAL COARSE control slowly clockwise until METER I indicates 20V.

(11) Unclamp the galvanometer (QC2A80), and zero the needle. Adjust the SPEED SIGNAL FINE control (QC2A80) so as to reduce the galvanometer deflection, depressing the GALVO key at frequent intervals to observe the effect on the galvanometer.

#### Note . . .

*For a galvanometer deflection the left of zero, the SPEED SIGNAL FINE control must be turned clockwise, and for a deflection to the right of zero, the control must be turned counter clockwise. When the galvanometer deflection is within 5 scale divisions of zero, set the GALVO key to READ.*

(12) Make final adjustments to the SPEED SIGNAL FINE control (QC2A80) to obtain a null on the galvanometer.

(13) Check that the reading on METER I is within  $\pm 2V$  of the figure specified by the manufacturers of the tachogenerator.

e.g. Kelvin and Hughes

Type KGA0801	26V
Elliot Type 30575 Mk. II	21V

(14) Set the SELECT METER TEST switch (QC2A80) to positions  $\emptyset 2$  and  $\emptyset 3$  in turn, and carry out the procedure detailed in sub-para. (11) and (12).

(15) The reading on METER 1, in each case, must be within  $\pm 1V$  of the reading obtained in sub-para. (13).

(16) Failure to achieve the readings specified above indicates a fault in the tachogenerator or test cables. . .

(17) Set the GALVO key to its central position and allow the motor unit QM2A80) to run for 5 minutes before proceeding further.

(18) Set the SPEED DATUM scale (QC2A80) to 70% and adjust the SPEED SIGNAL COARSE and FINE controls (QC2A80) to obtain a null on the galvanometer (QC2A80).

#### Temperature datum test.

56. (1) Set the DATUM TEMPERATURE scale (QT223) to the TAKE-OFF datum and set the DATUM SELECTOR control switch, on the flight deck, to TAKE-OFF.

(2) Set the T/C HARNESS SELECTOR switch (QT223) to the appropriate position as instructed in para. 54. If the jet-pipe temperature indicator, on the flight deck, is of the non-current drawing type, or uses separate thermocouples, set the T/C HARNESS SELECTOR switch to the SERVO POT position.

(3) Set the TEST SELECTOR switch (QT223) to D.C. SOL.

(4) Set the TEMP. DATUM/OFF/TEMPERATURE DATUM AND SIGNAL switch to TEMPERATURE DATUM AND SIGNAL.

(5) Set the METER II switch (QT223) to  $\div 2$ .

(6) Set the TEMP. SIGNAL FINE control (QT223) to its mid-position.

(7) Rotate the TEMP. SIGNAL COARSE control (QT223) slowly clockwise until meter II (QT223) indicates 450mA (true current 225mA).

(8) Unclamp the galvanometer (QT223), and zero the needle.

(9) Momentarily depress the GALVO key (QT223) to the SET UP position, and observe the deflection of the galvanometer needle. Adjust the DATUM TEMPERATURE scale

**RESTRICTED**

(QT223) so as to reduce the galvanometer reading, depressing the GALVO key at frequent intervals to observe the effect on the galvanometer.

**Note . . .**

*For a galvanometer deflection to the left of zero, the DATUM TEMPERATURE scale indication must be increased, and for a deflection to the right of zero, the scale indication must be decreased. When the galvanometer deflection is within 5 scale divisions of zero, set the GALVO key to GALVO IN.*

- (10) Make final adjustments to the TEMP. SIGNAL FINE control (QT223), if necessary, to maintain the 450mA indication on METER II.
- (11) Adjust the DATUM TEMPERATURE scale (QT223) to obtain a null on the galvanometer, and check that METER II still indicates 450mA.
- (12) Note the reading on the DATUM TEMPERATURE scale (QT223). This must be within  $\pm 2.5^{\circ}\text{C}$  of the TAKE-OFF datum.
- (13) If the DATUM TEMPERATURE scale reading is not within the specified limits, adjust the TEMPERATURE DATUM TRIM control on the amplifier until an acceptable figure is obtained. Each 'click' or step of the TEMPERATURE DATUM TRIM control corresponds to a datum change of  $2.5^{\circ}\text{C}$ .
- (14) Set the GALVO key (QT223) to its central position.
- (15) Set the DATUM SELECTOR switch, on the flight deck, to CLIMB.
- (16) Set the DATUM TEMPERATURE scale (QT223) to Climb datum, and carry out the procedure detailed in sub-para. (7) to (11) above.
- (17) The reading of the DATUM TEMPERATURE scale should be within  $\pm 2.5^{\circ}\text{C}$  of the CLIMB datum.
- (18) Set the DATUM SELECTOR control switch, on the flight deck, to CRUISE.
- (19) Set the DATUM TEMPERATURE scale (QT223) to the CRUISE datum, and carry out the procedure detailed in sub-para. (7) to (11) above.

(20) The reading on the DATUM TEMPERATURE scale should be within  $\pm 2.5^{\circ}\text{C}$  of the CRUISE datum.

(21) If either of the readings obtained in sub-para. (17) and (20) above are incorrect, the TEMPERATURE DATUM TRIM control in the amplifier may be adjusted as described in sub-para. (13). It should be remembered however, that all three datums are altered by a change in the setting of the DATUM TRIM control. It is therefore, necessary to recheck the three datums after the DATUM TRIM control has been reset.

**Temperature gain test**

- 57 (1) With the QT223 controls set up as at the conclusion of the temperature datum test, rotate the TEMP. SIGNAL FINE control (QT223) until METER II indicates 200mA (true current 100mA).
- (2) Carry out the procedure detailed in sub-para. 56 (9), and obtain a null on the galvanometer.
- (3) Note the reading on the DATUM TEMPERATURE scale (QT223). Set the GALVO key to its mid-position.
- (4) Adjust the TEMP. SIGNAL FINE control (QT223) until METER II indicates 700 mA (true current 350 mA).
- (5) Carry out the procedure detailed in sub-para. 56(9) and obtain a null on the galvanometer.
- (6) Note the reading on the DATUM TEMPERATURE scale (QT223).
- (7) The difference between the readings obtained in (3) and (6) above must be within the limits  $8^{\circ}\text{C}$  to  $11^{\circ}\text{C}$ .
- (8) Set the GALVO key (QT223) to its central position, and clamp the galvanometer.
- (9) Set the DATUM SELECTOR control switch, on the flight deck, to TAKE-OFF.

**Standing current test**

58. (1) With the QT223 controls set up as at the conclusion of the temperature gain test, set the TEMP. DATUM/

**RESTRICTED**

OFF / TEMPERATURE DATUM AND SIGNAL switch (QT223) to OFF.

(2) The current indicated on METER II (QT223) must not exceed 170 mA (true current 85 mA).

(3) Set the TEMP. SIGNAL COARSE and FINE CONTROLS (QT223) fully counter-clockwise).

#### R.P.M. datum test

59. (1) Set the SPEED DATUM scale (QC2A80) to 106%.

(2) Rotate the SPEED SIGNAL COARSE and FINE controls (QC2A80) slowly clockwise until METER II (QT223) indicates 450 mA (true current 225 mA).

(3) Momentarily depress the GALVO key (QC2A80) to SEARCH, and observe the deflection of the galvanometer needle. Adjust the SPEED DATUM scale (QC2A80) to reduce the galvanometer deflection, depressing the GALVO key at frequent intervals to observe the effect on the galvanometer.

#### Note . . .

*For a galvanometer deflection to the left of zero, the SPEED DATUM scale must be turned clockwise, and for a deflection to the right of zero, the scale must be turned counter-clockwise. When the galvanometer deflection is within 5 scale divisions of zero, set the GALVO key to READ.*

(4) Make final adjustments to the SPEED DATUM scale to obtain a null on the galvanometer. Check that METER II (QT223) still indicates 450 mA.

(5) Note the reading on the SPEED DATUM scale. This must be  $106\% \pm 0.3\%$ .

(6) If the SPEED DATUM scale reading is not within the specified limits, adjust the R.P.M. DATUM TRIM control on the Amplifier until an acceptable figure is obtained. Each 'click' or step of the R.P.M. DATUM TRIM control corresponds to a datum change of 0.3%.

(7) Set the GALVO key (QC2A80) to its mid-position.

#### R.P.M. gain test

60. (1) With the QC2A80 controls set up as at the conclusion of the r.p.m. datum test, rotate the SPEED SIGNAL FINE control (QC2A80) until METER II (QT223) indicates 200 mA (true current 100 mA).

(2) Carry out the procedure detailed in sub-para. 59 (3) and obtain a null on the galvanometer. Check that METER II (QT223) still indicates 200 mA.

(3) Note the reading on the SPEED DATUM scale (QC2A80). Set the GALVO key to its mid-position.

(4) Adjust the SPEED SIGNAL FINE control (QC2A80) to obtain a reading of 700 mA (true current 350 mA) on METER II (QT223).

(5) Carry out the procedure detailed in sub-para. 59 (3), and obtain a null on the galvanometer. Check that METER II (QT223) still indicates 700 mA.

(6) Note the reading on the SPEED DATUM scale (QC2A80). Set the GALVO key to its mid-position.

(7) The difference between the readings obtained in (3) and (6) above must be within the limits of 1.5% to 2%.

#### Low r.p.m. datum test

61. (1) Set the SELECT METER TEST switch (QC2A80) to  $\emptyset$ 1.

(2) Turn the SPEED SIGNAL COARSE control (QC2A80) counter-clockwise until METER I (QC2A80) indicates less than 20V.

(3) Set the DATUM SELECTOR switch (QC2A80) to LOW.

(4) Adjust SPEED SIGNAL FINE control (QC2A80) until METER II (QT223) indicates 450 mA (true current 225 mA).

(5) Set the SPEED DATUM scale (QC2A80) to 90.2%.

(6) Carry out the procedure detailed in sub-para. 59 (3), and obtain a null on the galvanometer.

(7) Note the reading on the SPEED DATUM scale (QC2A80). This must be  $90.2\% \pm 0.3\%$ . Set the GALVO key to its mid-position.

**RESTRICTED**

**Disconnecting the test equipment**

62. (1) Set the SELECT SPEED MEASUREMENT RANGE switch (QC2A80) to OFF.
- (2) Set the TEMP. SIGNAL COARSE and FINE controls (QT223) fully counter-clockwise.
- (3) Set the SPEED SIGNAL COARSE and FINE controls (QC2A80) fully counter-clockwise.
- (4) Clamp the two galvanometers (QC2A80) and (QT223).
- (5) Switch off the aircraft supplies.
- (6) Disconnect the test equipment.
- (7) Reconnect the aircraft connections.
- (8) Replace the blanking cap on the aircraft test plug.

**Aircraft test—ground running conditions**

63. (1) Connect the test equipment to the aircraft cabling as shown in fig. 7.
- (2) Set the TEMP. SIGNAL COARSE and FINE controls fully counter-clockwise.
- (3) Set the TEST SELECTOR SWITCH to D.C. SOL. Set METER II switch to  $\div 2$ . Set SPEED DATUM /REHEAT switch to OFF.
- (4) Start up the engine associated with the amplifier to be tested.
- (5) Set the engine speed to 70% as indicated on the revolution counter on the flight deck.
- (6) Adjust the TEMP. SIGNAL COARSE and FINE controls until METER II indicates 200 mA (true current 100 mA).

(7) Slowly increase the throttle lever setting.

(8) The engine speed should not rise by more than 1.5% and the reading on METER II should rise to approximately 700 mA, (true current 350 mA). Set TEMP. SIGNAL COARSE and FINE controls fully counter-clockwise.

(9) Adjust the engine speed to the low datum figure recorded in para. 61 (7).

(10) Set the SPEED DATUM/REHEAT switch to SPEED DATUM, and check that the reading on METER II is  $450 \text{ mA} \pm 40 \text{ mA}$  (true current  $225 \text{ mA} \pm 20 \text{ mA}$ ). If necessary, adjust the R.P.M. TRIM control on the amplifier to obtain this figure.

(11) Shut down the engine.

(12) Disconnect the test equipment, and replace the aircraft connections.

**FAULT FINDING****Measurements**

64. Should the preceding tests, or the tests in Appendix A, indicate that the amplifier is faulty, it may be possible to locate the fault by measuring the voltage, and resistance between certain seals inside the amplifier or by applying a continuity test to the amplifier.

65. Table 1 gives the values of voltage, and resistance which should be obtained when measuring these voltages and resistances. Fig. 4 illustrates the locations of the various canisters inside the amplifier, and identifies their seal numbers. Resistance values for the continuity tests are given in Table 2.

**RESTRICTED**

TABLE 1

## Voltage and resistance measurements

Stage	Circuit	Seals	Voltage	Resistance
RECTIFIER UNIT	Feedback transformer primary	3 & 4	—	35 $\Omega$
	Feedback transformer secondary	5 & 6	—	8 $\Omega$
	Input to rectifier bridge	13 & 14	49V a.c.	100 $\Omega$
	Output from rectifier bridge	7 & 9	20V d.c.	1.8k $\Omega$
	Resistors R17, R61	11 & 17	10.5V d.c. (dependent on settings of RV4 & RV16)	1.1k $\Omega$
	MR7, R18 fwd. res.	14(-) & 7(+)	—	5.5k $\Omega$
	MR7, R18 rev. res.	14(+) & 7(-)	—	17k $\Omega$
	MR5, R18 fwd. res.	13(-) & 7(+)	—	5.5k $\Omega$
	MR5, R18 rev. res.	13(+) & 7(-)	—	17k $\Omega$
	MR6 fwd. res.	9(-) & 13(+)	—	1.5k $\Omega$
	MR6 rev. res.	9(+) & 13(-)	—	20k $\Omega$
	MR8 fwd. res.	9(-) & 14(+)	—	1.5k $\Omega$
	MR8 rev. res.	9(+) & 14(-)	—	20k $\Omega$
	R44	18 & 19	—	90 $\Omega$
R43	19 & 20	—	90 $\Omega$	
C.J.C. UNIT	Ref. volts and C.J.C. bridge	1 & 2	—	1 $\Omega$
		2 & 3	—	370 $\Omega$
		2 & 4	—	2.8 $\Omega$
		3 & 5	—	370 $\Omega$
		5 & 8	—	17.5 $\Omega$
	Resistor R14	9 & 10	—	0.5 $\Omega$
DISCRIMINATOR UNIT	Transformer input	8 & 9	33V a.c.	1.5 $\Omega$
	Transformer output	6 & 7	49V a.c.	105 $\Omega$
	D.C. supply for Maxwell Bridge	5(-) & 11(+)	19V d.c.	1.8k $\Omega$
	Tacho input	1 & 2	K & H tacho 26V Elliot tacho 21V	10k $\Omega$

RESTRICTED

TABLE 1—(cont.)  
Voltage and resistance measurements

Stage	Circuit	Seals	Voltage	Resistance
TRANSFORMER UNIT	Transformer primary	7 & 8	115V a.c.	9.3Ω
	Supply to stages 1A & 2A	1 & 2	5.75V a.c.	1.3Ω
		2 & 3	5.75V a.c.	1.3Ω
	Supply to stages 1 & 2	13 & 14	5.75V a.c.	1.3Ω
		14 & 15	5.75V a.c.	1.3Ω
	Supply to stage 3	4 & 5	5.75V a.c.	1.3Ω
		4 & 6	5.75V a.c.	1.3Ω
	Supply to output stage and discriminator	9 & 10	33.5V a.c.	1.7Ω
	Supply to voltage stabilising bridge	11 & 12	62.5V d.c.	—
	STAGES 1A & 2A	Stage 1A control	19 & 20	—
Stage 1A low datum		11 & 12	—	23Ω
		6 & 11	—	23Ω
Stage 1A —ve f/b		5 & 8	—	100Ω
Stage 1A anticipation		7 & 13	—	75Ω
Stages 1A & 2A bias, mixing and control		10 & 15	—	0.5Ω
Stage 2A output and bias		4(+) & 5(-)	—	46Ω
Supply to stage 1A		16 & 17	5.75V a.c.	1.3Ω
		17 & 18	5.75V a.c.	1.3Ω
Supply to stage 2A		1 & 2	5.75V a.c.	1.3Ω
	2 & 3	5.75V a.c.	1.3Ω	
STAGES 1 & 2	Stage 1 control	19 & 20	—	60Ω
	Stage 1 anticipation	4 & 11	—	190Ω
	Stage 1 —ve f/b	5 & 7	—	100Ω
	Stages 1 & 2 bias, mixing and control	10 & 15	—	0.5Ω
	Stage 2 output and bias	4 & 5	—	150Ω
	Supply to stage 1	16 & 17	5.75V a.c.	1.3Ω
		17 & 18	5.75V a.c.	1.3Ω
	Supply to stage 2	1 & 2	5.75V a.c.	1.3Ω
	2 & 3	5.75V a.c.	1.3Ω	

RESTRICTED

TABLE 1—(Cont.)  
Voltage and resistance measurements

Stage	Circuit	Seals	Voltage	Resistance
STAGE 3	Control winding (r.p.m.)	10 & 11	—	100 to 150 $\Omega$
	Control winding (temp.)	8 & 9	—	100 to 150 $\Omega$
	Diode MR26	10(+) & 13(-)	—	100 to 150 $\Omega$
	Diode MR27	8(+) & 19(-)	—	100 to 150 $\Omega$
	Transient f/b winding	4 & 5	—	40 $\Omega$
	Bias winding	17 & 18	2mV d.c.	2.7 $\Omega$
	Output and mixing	6 & 7	—	13.5 $\Omega$
	Supply	1 & 2	5.75V a.c.	1.3 $\Omega$
		2 & 3	5.75V a.c.	1.3 $\Omega$
		Bias supply	12 & 14	0.3V d.c.
	Supply to voltage stabilising bridge	15 & 16	62.5V d.c. ...	—
	Output from voltage stabilising bridge	14 & 20	3.6V d.c. ...	—
OUTPUT STAGE	Control winding	4 & 5	—	13.5 $\Omega$
	Bias winding	7 & 8	0.27V d.c.	34 $\Omega$
	Transient feedback winding	1 & 10	—	2 $\Omega$
		1 & 11	—	35 $\Omega$
		9(-) & 12(+)	—	1k $\Omega$
	Output	9(+) & 12(-)	—	66 $\Omega$
	Feedback resistor, R40	2 & 12	—	0.5 $\Omega$
Supply from transformer	3 & 6	33.5V a.c.	—	

Note . . .

- (1) Measurements should be made using a Multimeter Type 12889 Ref. No.
- (2) Resistance measurements are undertaken with the amplifier disconnected from all external circuits.
- (3) Voltage measurements are undertaken with the amplifier energised from a 115V, 400 c/s supply. Whilst measur-

- ing voltages at the Rectifier Unit, a speed signal should be injected using the circuit shown in fig. 1 of Appendix A. The level of the speed signal should be such as to give an amplifier output of 225mA.
- (4) Tolerances are  $\pm 15\%$  for resistance measurements and  $\pm 10\%$  for voltage measurements.

TABLE 2

## Resistance values for continuity tests

Plug or Socket	Poles	Resistance
400 C.P.S. SUPPLY TEMPERATURE SELECTOR	A & B	9.3Ω
	A & B	1.4kΩ
	B & C	700Ω
TACHO GENERATOR SOLENOID VALVE	A & C	700Ω
	A & B	10kΩ
	C & D	0.5Ω
	A(-) and B(+)	1kΩ
	E & F	1.65kΩ
		(Dependent on setting of RV15).

**Insulation resistance**

66. The insulation resistance between the following points should be not less than 20MΩ when measured with a 500V d.c. insulation resistance tester.

**Caution . . .**

*Disconnect the thermocouple before applying the insulation tests.*

(1) Thermocouple terminals, and the chassis.

(2) All plug and socket pins, and the chassis.

(3) All Tachogenerator plug pins, and the Thermocouple +ve terminal.

(4) All 400 C.P.S. Supply plug pins, and the Thermocouple +ve terminal.

(5) All Tachogenerator plug pins, and all 400 C.P.S. Supply plug pins.

(6) All Solenoid Valve socket pins, and all 400 C.P.S. Supply plug pins.

(7) All Tachogenerator plug pins, and all Solenoid Valve socket pins.

**RESTRICTED**

1000

1000

1000

1000

1000

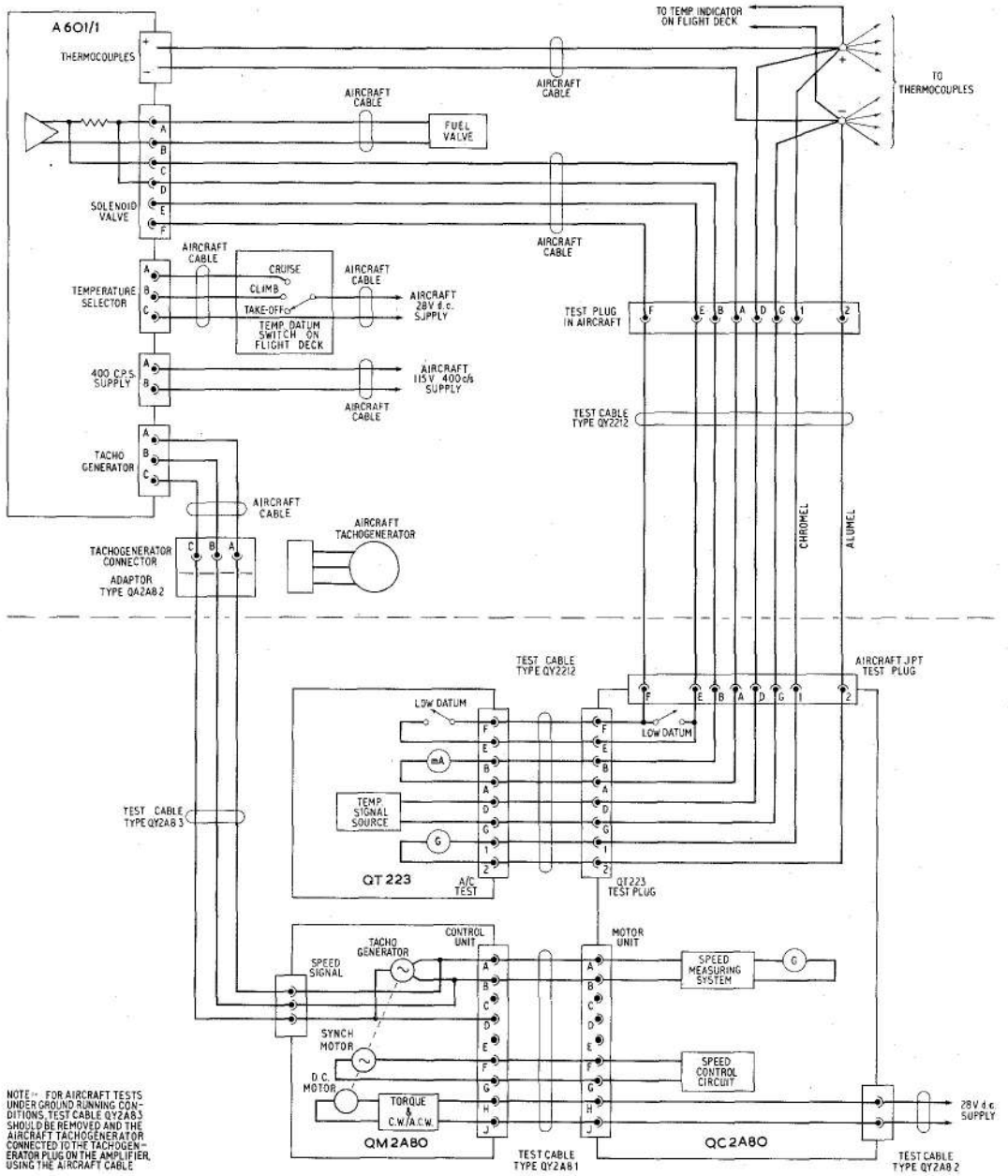

**Fig. 7 Aircraft test connections**  
**RESTRICTED**

2

3

4

5



### R.P.M. STAGES 1A & 2A

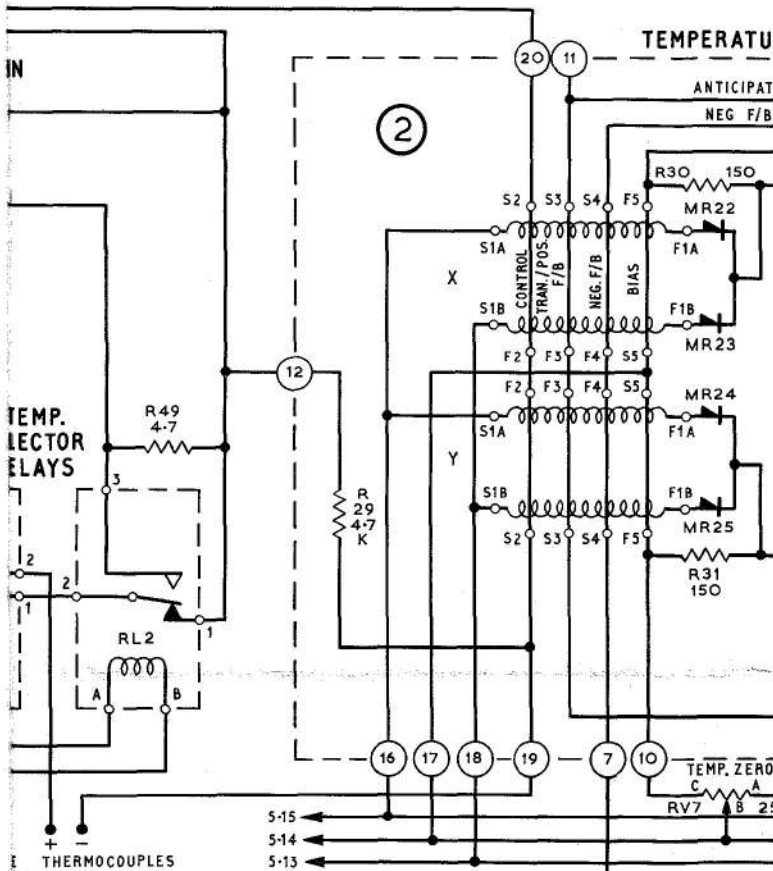
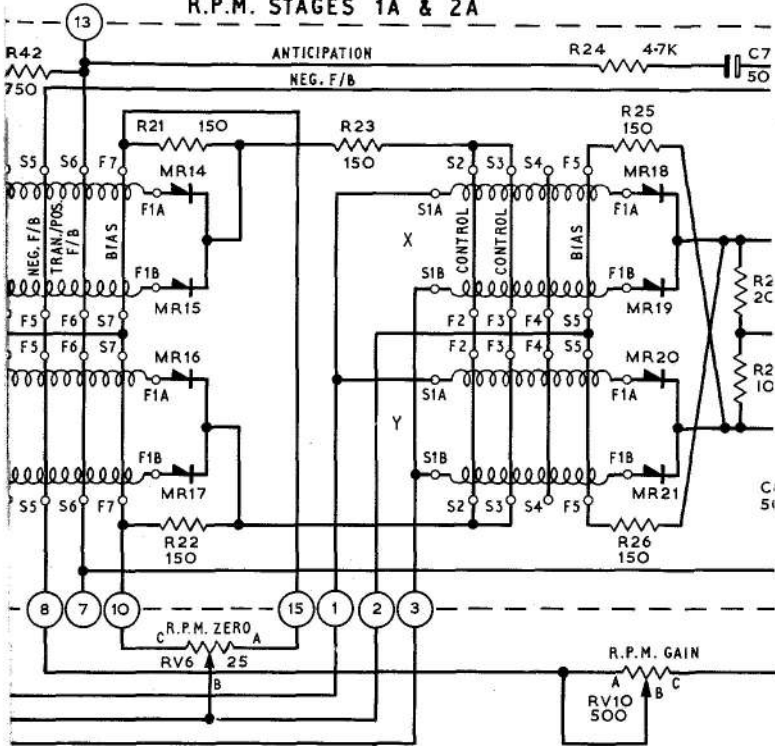

5-15  
5-14  
5-13

TEMPERATURE  
THERMOCOUPLES

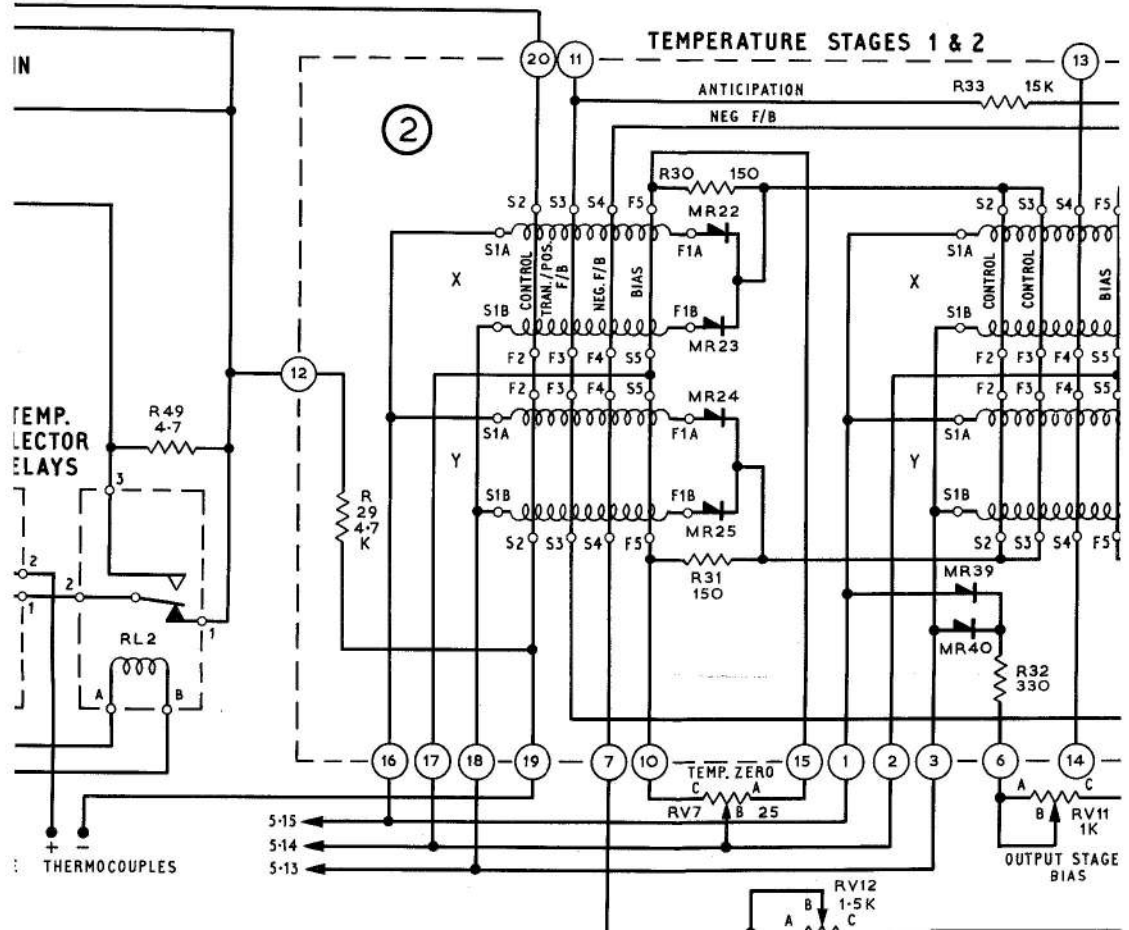
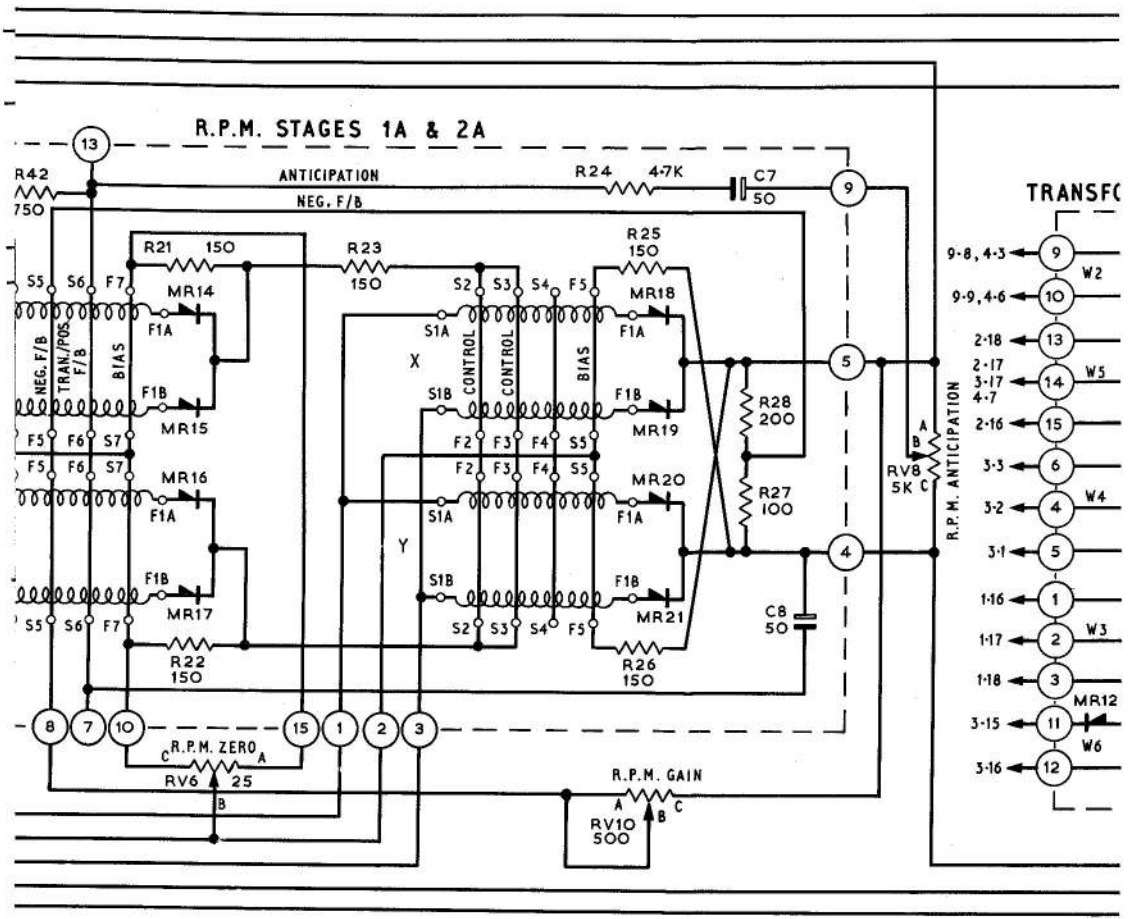

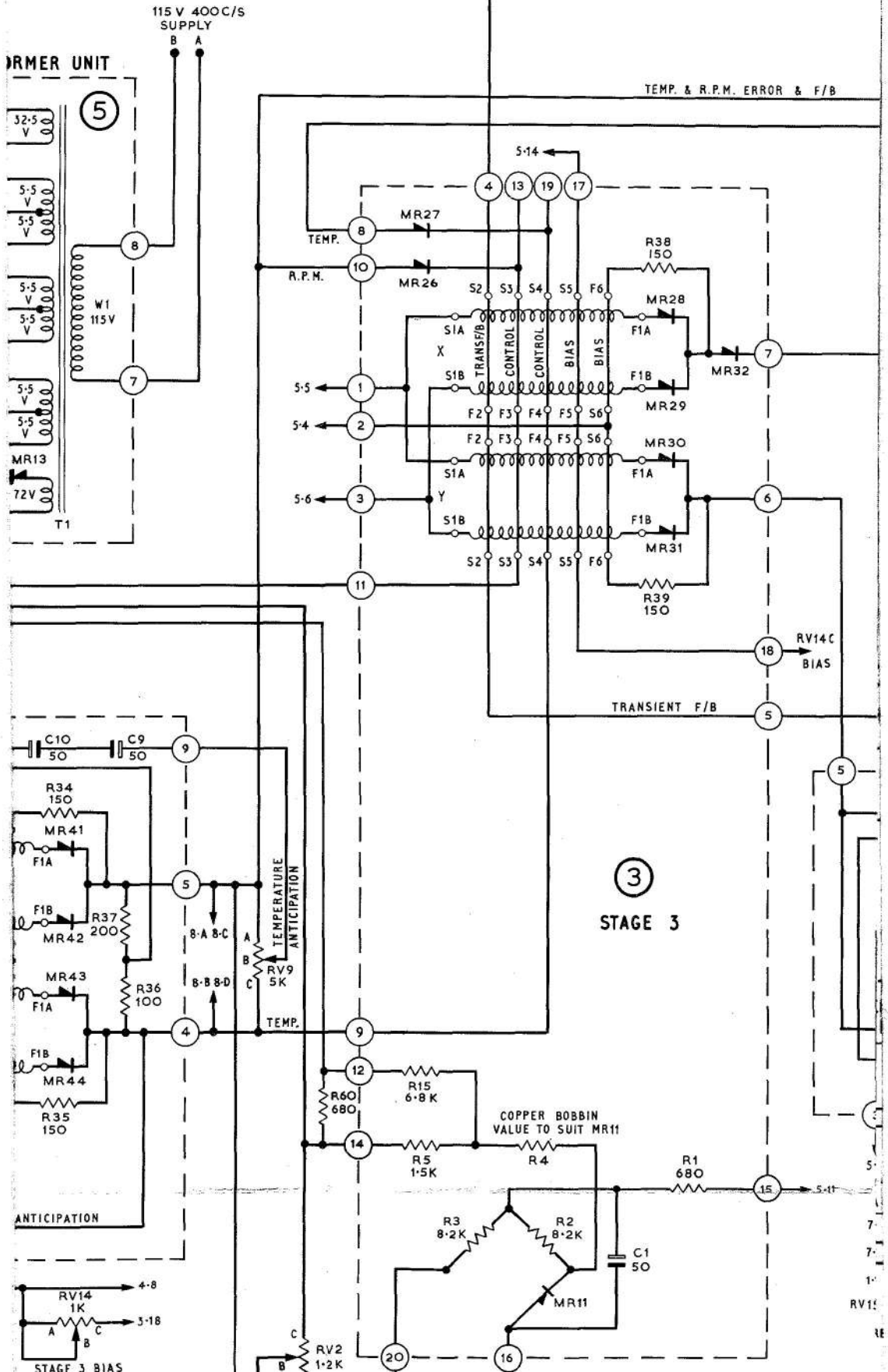

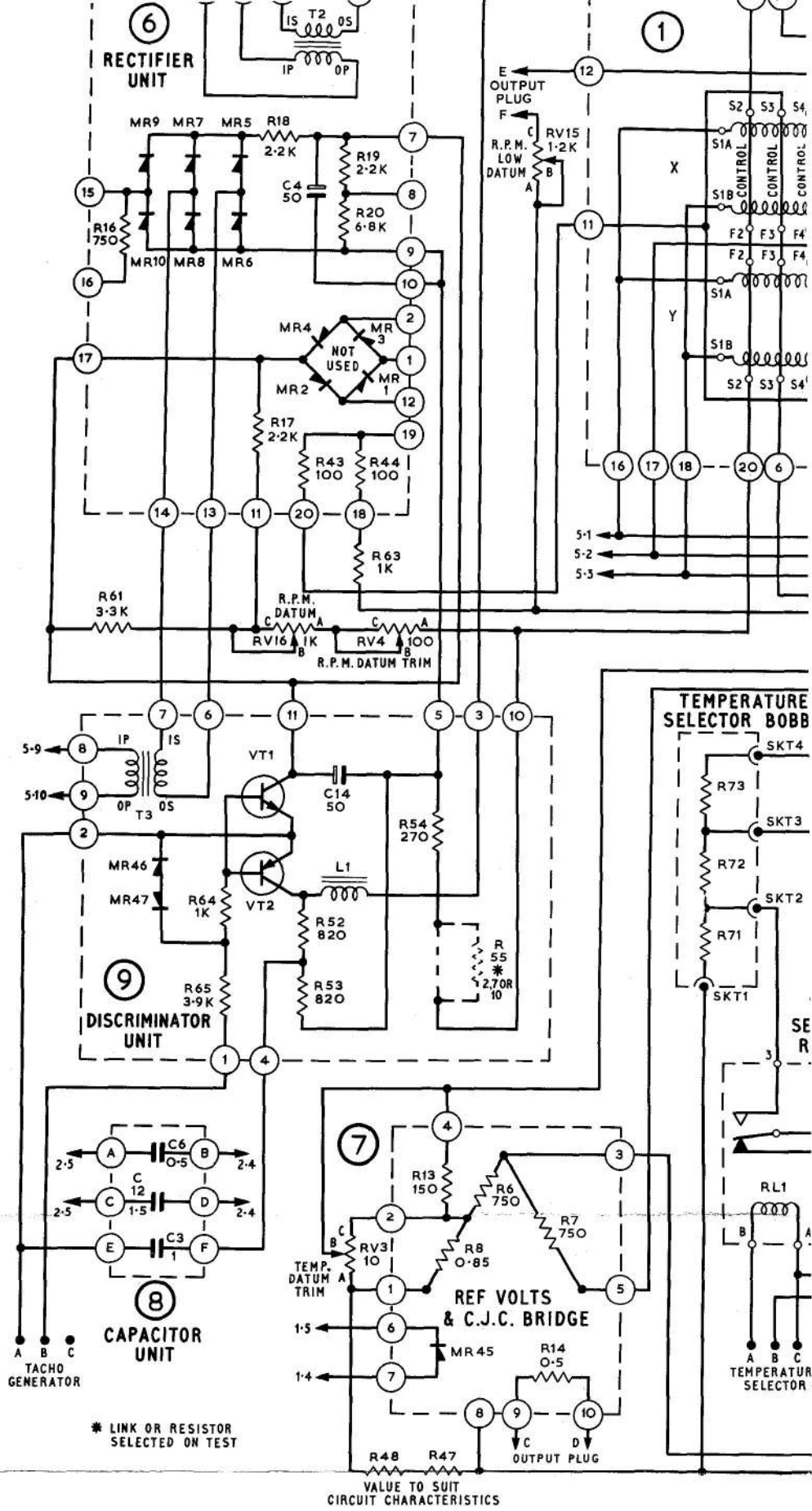
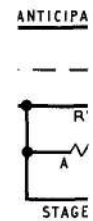
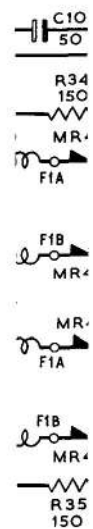
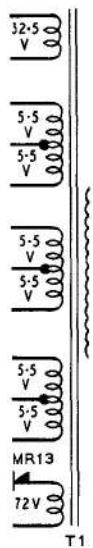

\* LINK OR RESISTOR SELECTED ON TEST

VALUE TO SUIT  
CIRCUIT CHARACTERISTICS

6C Fig.8  
:D





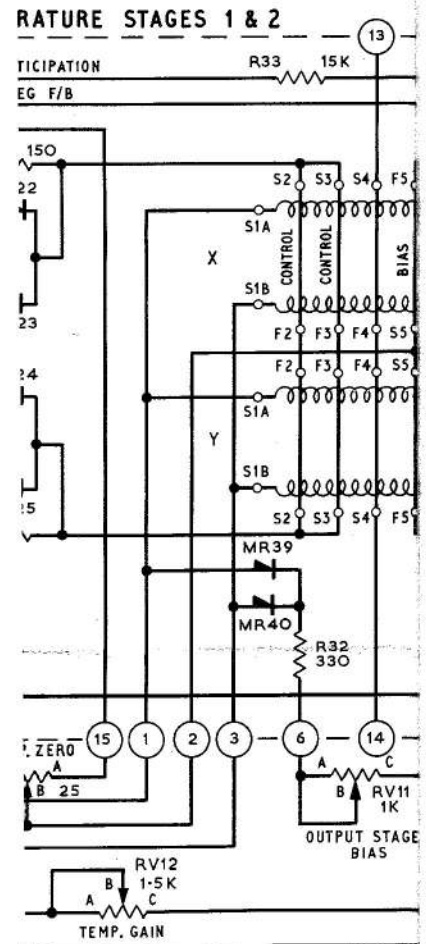
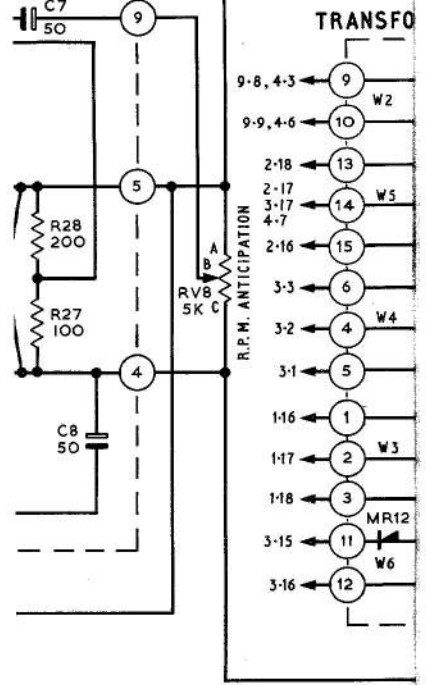
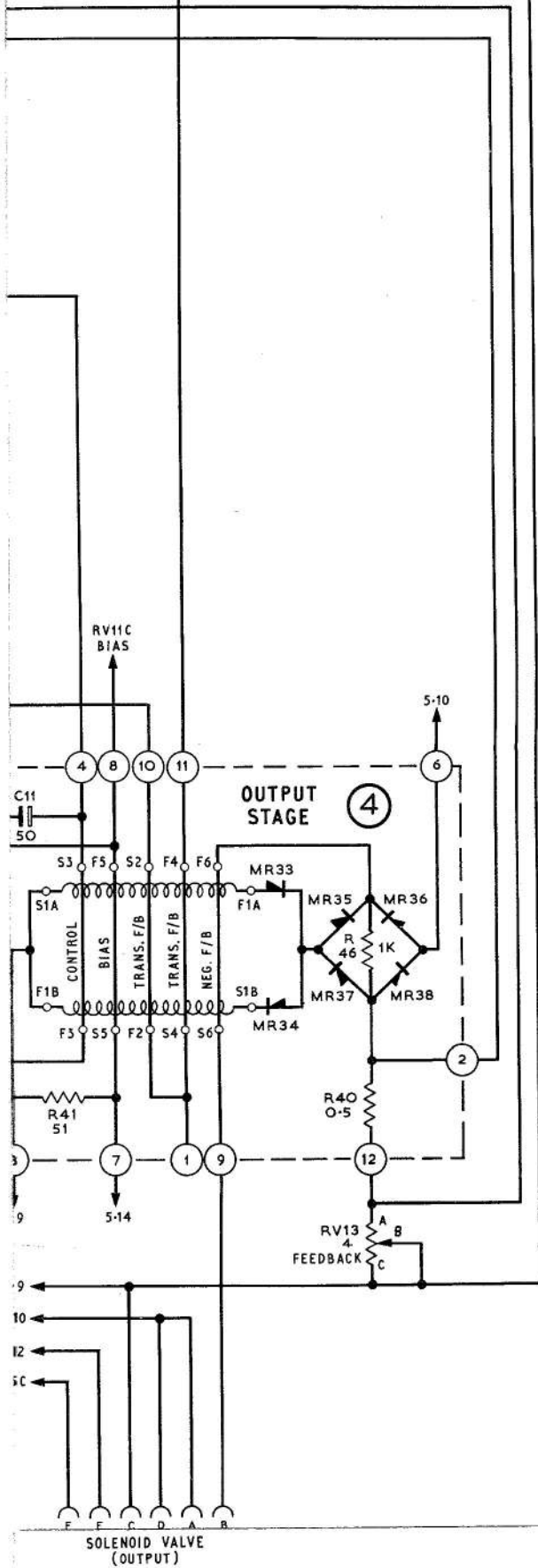

Fig.8

zr. Ultra. Type A  
RESTRICTED

**Appendix A**  
**STANDARD SERVICEABILITY TEST**  
**for**  
**AMPLIFIER, ULTRA, TYPE A601/1**

**Introduction**

1. The tests detailed in this Appendix may be applied to the unit before it is put into service, or at any time to determine its serviceability.

**TEST EQUIPMENT**

2. The following test equipment is required:—

- (1) Test set, Ultra Type QT223
- (2) Control unit, Ultra, Type QC2A80
- (3) Motor unit, Ultra, Type QM2A80
- (4) Temperature step function unit, Ultra, Type QE2232
- (5) Test cable, Ultra, Type QY2212
- (6) Test cable, Ultra, Type QY2A8.1
- (7) Test cable, Ultra, Type QY2A8.2
- (8) Test cable, Ultra, Type QY2A8.3
- (9) Test cable, Ultra, Type QY2216
- (10) Test cable, Ultra, Type QY2A8.9
- (11) Test cable, Ultra, Type QY2A8.10
- (12) Adapter for item (8)\*
- (13) Adapter for item (9)\*
- (14) Adapter for item (10)\*
- (15) Adapter for item (11)\*
- (16) Test circuit as illustrated in fig. 1.
- (17) Temperature selector bobbin Type ZR86/BV (Ref. No. 5CZ/7391). See A.P. 4343K, Vol. 1, Sect 6, Chap. 1.
- (18) Stop watch.

\*Local manufacture—to suit amplifier connectors.

**POWER SUPPLIES**

3. The following power supplies are required:—

- (1) 115V, 400 c/s, 1-ph, capable of supplying up to 50VA.
- (2) 28V d.c., capable of supplying a current of up to 6A.

**Preparation**

4. Before connecting the test equipment to the amplifier, Type A601/1, the following procedure must be carried out.

- (1) Set the TEMP. DATUM/OFF/TEMPERATURE DATUM & SIGNAL switch (QT223) to TEMPERATURE DATUM & SIGNAL.
- (2) Set the TEST SELECTOR switch (QT223) to BATTERY, and check that the needle of METER II (QT223) is in the green zone. If it is not, renew the reference source battery in the QT223 (Mallory Type SKB 544 Ref. No. 5J/3465).
- (3) Set the TEST SELECTOR switch (QT223) to T/C RES.
- (4) Set the T/C HARNESS SELECTOR switch (QT223) to G.
- (5) Depress the T/C RESIST. TEST switch (QT223) to the T/C RESIST. TEST position.
- (6) Rotate the TEMP. SIGNAL COARSE control (QT223) slowly clockwise.
- (7) METER II (QT223) should indicate full scale deflection before the COARSE control reaches full travel. If full scale deflection is not indicated, renew the temperature signal source battery in the QT223 (Mallory Type SKB536 Ref. No. 5J/3464).

**RESTRICTED**

(8) Set the SPEED DATUM/RE-HEAT switch (QT223) to its centre position.

(9) Set the TEMP. DATUM/OFF/TEMPERATURE DATUM & SIGNAL switch (QT223) to OFF.

(10) Set the TEMP. SIGNAL COARSE and FINE controls (QT223) fully counter-clockwise.

(11) Set METER II switch (QT223) to +2.

(12) Set the TEST POSITION switch (QC2A80) to BENCH.

(13) Set the SPEED SIGNAL COARSE and FINE controls (QC2A80) fully counter-clockwise.

(14) Set the SPEED DATUM scale (QC2A80) to 100%.

(15) Set the SELECT METER TEST switch (QC2A80) to BATT.

(16) Set the SELECT SPEED MEASUREMENT RANGE switch (QC2A80) to position 1.

(17) Check that the needle of METER I (QC2A80) is in the green zone. If not, renew the battery in the QC2A80 (Mallory Type SKB 544 Ref. No. 5J/3465).

(18) Set the SELECT MEASUREMENT RANGE switch (QC2A80) to OFF.

(19) Check that the tachogenerator, in the motor unit (QM2A80), is Elliot Type 30575 Mk. 11 or Kelvin & Hughes Type KGA0801.

### Connections

5. Connect the test equipment, power supplies and amplifier under test as illustrated in fig. 1. Do not switch on the power supplies. The QE2232 is attached to the case of the QT223 by two captive screws.

### Power supply

6. (1) Switch the 400c/s supply ON, and allow a five minute warm-up time.

(2) Set the TEST SELECTOR switch (QT223) to C.P.S. and check that METER (QT223) indicates 400c/s. The PHASING lamp (QT223) should be lit.

(3) Set the TEST SELECTOR switch (QT223) to VOLTS, and check that the needle of METER II (QT223) is in the BLUE zone. The PHASING lamp (QT223) should be extinguished.

### Selector bobbin

7. Plug the temperature datum selector bobbin, specified in para. 2 (17) into the lower of the two sockets in the amplifier, Type A601/1.

### Temperature datum

8. (1) Set the DATUM SELECTOR switch (QC2A80) to TAKE-OFF, and the IN/OUT switch (QE2232) to OUT.

(2) Set the DATUM TEMPERATURE scale (QT223) to approximately 690°C.

(3) Set the T/C HARNESS SELECTOR switch (QT223) to SERVO POT.

(4) Set the TEST SELECTOR switch (QT223) to D.C. SOL.

(5) Set the TEMP. DATUM/OFF/TEMPERATURE DATUM & SIGNAL switch (QT223) to TEMPERATURE DATUM & SIGNAL.

(6) Set the SELECT METER TEST switch (QC2A80) to D.C. SOL.

(7) Set the TEMP. SIGNAL FINE control (QT223) to its mid-position.

(8) Rotate the TEMP. SIGNAL COARSE control (QT223) slowly clockwise until METER II (QT223) indicates 450 mA (225 mA true reading).

(9) Unclamp and zero the galvanometer (QT223).

### Note . . .

*For a galvanometer deflection to the left of zero, the scale indication must be increased, and for a deflection to the right the scale indication must be decreased. When the deflection is within 5 scale divisions of zero, set the GALVO key to GALVO IN.*

(10) Momentarily depress the GALVO key (QT223) to the SET UP position, and observe the deflection of the galvanometer needle. Adjust the DATUM TEMPERATURE scale (QT223) to reduce the galvanometer deflection to zero.

(11) Adjust the TEMP. SIGNAL FINE control (QT223), if necessary, to maintain the 450 mA indication on METER II (QT223).

(12) Adjust the DATUM TEMPERATURE scale (QT223) to obtain final balance on the galvanometer, and check that METER II (QT223) still indicates 450 mA.

**RESTRICTED**

- (13) The DATUM TEMPERATURE scale (QT223) should indicate  $690^{\circ}\text{C} \pm 2.5^{\circ}\text{C}$ .
- (14) Set the GALVO key (QT223) to its mid-position, and set the DATUM SELECTOR (QC2A80) to CLIMB.
- (15) Repeat the procedure detailed in sub-para. (8) to (12) above.
- (16) The DATUM TEMPERATURE scale (QT223) should indicate  $665^{\circ}\text{C} \pm 2.5^{\circ}\text{C}$ .
- (17) Set the GALVO key (QT223) to its mid-position and set the DATUM SELECTOR (QC2A80) to CRUISE.
- (18) Repeat the procedure detailed in sub-para. (8) to (12) above.
- (19) The DATUM TEMPERATURE scale (QT223) should indicate  $630^{\circ}\text{C} \pm 2.5^{\circ}\text{C}$ .
- (20) If any of the datums specified in sub-para. (13), (16) or (19) are outside their limits adjust the TEMPERATURE DATUM trim control on the amplifier to obtain an acceptable figure for all three datums. Each step of the trim control corresponds to a datum change of  $2.5^{\circ}\text{C}$ . Care must be taken to ensure that all three datums are within their  $\pm 2.5^{\circ}\text{C}$  limits.
- (21) Set the GALVO key (QT223) to its mid-position but leave the other controls as set up.

#### Temperature gain

9. (1) With the test equipment controls set up as at the conclusion of the temperature datum test (para. 8), rotate the TEMP. SIGNAL FINE control (QT223) until METER II (QT223) indicates 200 mA (100 mA true reading).
- (2) Carry out the procedure detailed in sub-para. 8 (8) to 8 (12) maintaining the 200 mA reading on METER II (QT223).
- (3) Record the reading of the DATUM TEMPERATURE scale (QT223), and set the GALVO key (QT223) to its mid-position.
- (4) Rotate the TEMP. SIGNAL FINE control (QT223) until METER II (QT223) indicates 700 mA (true reading 350 mA).

- (5) Carry out the procedure detailed in sub-para. 8 (8) to 8 (12) maintaining the 700 mA reading on METER II (QT223).
- (6) Record the reading of the DATUM TEMPERATURE scale (QT223), and set the GALVO key (QT223) to its mid-position.
- (7) Subtract the reading obtained in sub-para. (3) from that obtained in sub-para. (6). The difference should be  $8^{\circ}\text{C}$  to  $10^{\circ}\text{C}$ .
- (8) Clamp the galvanometer but leave the other controls set up.

#### Temperature channel response time

10. (1) Set the TEMP. DATUM/OFF/TEMPERATURE DATUM & SIGNAL switch (QT223) to TEMPERATURE DATUM & SIGNAL.
- (2) Set the DATUM SELECTOR switch (QT223) to TAKE-OFF, and the IN/OUT switch (QE2232) to OUT.
- (3) Set the TEST SELECTOR switch (QT223) to D.C. SOL.
- (4) Set the T/C HARNESS SELECTOR switch (QT223) to SERVO-POT.
- (5) Set the TEMP. SIGNAL COARSE and FINE controls (QT223) to obtain an indication on METER II (QT223) of 700 mA (true reading 350 mA).
- (6) Carry out the procedure detailed in sub-para. 8 (9) and 8 (10) to obtain null conditions on the galvanometer (QT223), and check that METER II (QT223) still indicates 700 mA.
- (7) Note the reading on the DATUM TEMPERATURE scale (QT223), and set the GALVO key (QT223) to its mid-position.
- (8) Set the IN/OUT switch (QE2232) to IN.
- (9) Set the DATUM TEMPERATURE scale (QT223) to a temperature  $11^{\circ}\text{C}$  lower than that noted in sub-para. (7).
- (10) Adjust the FINE and COARSE controls (QE2232) to obtain a null on the galvanometer (QT223). Check that the indication on METER II (QT223) is 90 to 110 mA (true reading 45 to 55 mA). Set the GALVO key (QT223) to its mid-position.

RESTRICTED

(11) Set the IN/OUT switch (QE2232) to OUT and, using the stopwatch, note the time taken for the indication on METER II (QT223) to rise from 200 mA to 500 mA. (true reading 100 mA to 250 mA).

(12) Repeat sub-para. (8) and (11) three times, and calculate the average of the four intervals. This should be within the limits 3 to 5 sec.

#### Standing current

11 (1) With the test equipment controls set up as at the conclusion of the temperature gain test (para. 9), set the TEMP. DATUM / OFF / TEMPERATURE DATUM & SIGNAL switch (QT223) to OFF.

(2) The indication on METER II (QT223), at this point, should be 90 to 110 mA (true reading 45 to 55 mA).

(3) On METER II (QC2A80), note the output current:—

(a) with the amplifier thermocouple terminals short-circuited, and

(b) with the amplifier thermocouple terminals open-circuited.

(4) Under neither condition must the reading on METER II (QT223) exceed 85 mA.

(5) Clamp the galvo (QT223), and set the TEMP. SIGNAL COARSE and FINE controls (QT223) fully counter-clockwise.

#### Preparations for r.p.m. channel checks

12. (1) Set the TORQUE switch (QM2A80) to HIGH.

(2) Set the ROTATION switch (QM2A80) to A.C.W.

(3) Set the A/C TESTS switch (QM2A80) to STATIC.

(4) Set the DATUM SELECTOR switch (QC2A80) to HIGH.

(5) Set the TACHO GENERATOR LOAD switch (QC2A80) to IND. & RESIST.

(6) Set the SELECT SPEED MEASUREMENT RANGE switch (QC2A80) to position 1.

(7) Set the 28V D.C. SUPPLY switch (QC2A80) to ON, and check that the SUPPLY lamp is lit. If the lamp does not light, check polarity of the d.c. supply (+ve to pole A of the SUPPLY plug).

(8) Set the SELECT METER TEST switch (QC2A80) to  $\emptyset 1$  and check that METER I (QC2A80) indicates that an output voltage is being produced by the tachogenerator.

(9) Rotate the SPEED SIGNAL COARSE control (QC2A80) slowly clockwise until the a.c. motor in the motor unit, QM2A80, reaches synchronous speed. This is indicated by a slowly increasing reading on METER I (QC2A80).

#### Caution . . .

*Avoid running the a.c. motor for long periods at non-synchronous speeds.*

(10) Continue to rotate the SPEED SIGNAL COARSE control (QC2A80) slowly clockwise until METER I (QC2A80) indicates 20V.

(11) Unclamp the galvanometer (QC2A80) and, if necessary, zero the needle.

(12) Momentarily depress the GALVO key (QC2A80) to the SEARCH position, and observe the deflection of the galvanometer reading. Adjust the SPEED SIGNAL FINE control (QC2A80), depressing the GALVO key (QC2A80) at frequent intervals to observe the effect on the galvanometer.

#### Note . . .

*For a galvanometer deflection to the left of zero turn the SPEED SIGNAL FINE control clockwise, and for a deflection to the right of zero turn the control counter-clockwise. When the deflection is within five scale divisions of zero, set the GALVO key to READ.*

(13) Make final adjustments to the SPEED SIGNAL FINE control (QC2A80) to obtain a null on the galvanometer.

(14) Check that the reading on METER I (QC2A80) is within  $\pm 2V$  of the figure specified below for the tachogenerator used in the motor unit, Type QM2A80:

Elliot	
Type 30575 Mk. II	21V.
Kelvin & Hughes	
Type KGA0801	26V

(15) Set the SELECT METER TEST

**RESTRICTED**

switch (QC2A80) to positions  $\emptyset 2$  and  $\emptyset 3$  in turn, and carry out procedure detailed in sub-para. (12) and (13) above. In each instance, the reading of METER I (QC2A80) must be within  $\pm 1V$  of the reading obtained in sub-para. (14). Failure to achieve the above test figures indicates a fault in the tacho-generator or test cables.

(16) Set the GALVO key (QC2A80) to its mid-position, and allow a five minute warm-up time.

#### R.P.M. datum

13. (1) Set the SPEED DATUM scale (QC2A80) to 160%.
- (2) Rotate the SPEED SIGNAL FINE control (QC2A80) slowly clockwise until METER I (QC2A80) indicates 225 mA. METER II (QT223) can be used to give a more sensitive indication.
- (3) Momentarily depress the GALVO key (QC2A80) to SEARCH, and observe the deflection of the galvanometer needle. Adjust the SPEED DATUM scale (QC2A80) to reduce the galvanometer deflection, depressing the GALVO key at frequent intervals to observe the effect on the galvanometer.

#### Note . . .

*For a galvanometer deflection to the left of zero, turn the SPEED DATUM scale clockwise, and for a deflection to the right zero, turn the SPEED DATUM scale counter-clockwise. When the deflection is within five scale divisions of zero, set the GALVO key to READ.*

- (4) Make final adjustments to the SPEED DATUM scale to obtain a null on the galvanometer. Check that METER I (QC2A80) still indicates 225 mA.
- (5) The reading on the SPEED DATUM scale (QC2A80) should be  $106\% \pm 0.3\%$ . If the reading is not within these limits, adjust the R.P.M. DATUM trim control on the amplifier under test until an acceptable figure is obtained. Each step of the trim control corresponds to a datum change of approximately 0.3%.

- (6) Set the GALVO key (QC2A80) to its mid-position.

#### R.P.M. gain

14. (1) With the QC2A80 controls set up as at the conclusion of the r.p.m. datum check in para. 13 rotate the SPEED SIGNAL FINE control (QC2A80) until METER I (QC2A80) indicates 100 mA.
- (2) Carry out the procedures detailed in sub-para. 13 (3), and obtain a null on the galvanometer. Check that METER I (QC2A80) still indicates 100 mA.
- (3) Note the reading on the SPEED DATUM scale (QC2A80), and set the GALVO key (QC2A80) to its mid-position.
- (4) Adjust the SPEED SIGNAL FINE control (QC2A80) to obtain an indication of 350 mA on METER I (QC2A80).
- (5) Carry out the procedure detailed in sub-para. 13 (3), and obtain a null on the galvanometer. Check that METER I (QC2A80) still indicates 350 mA.
- (6) Note the reading on the SPEED DATUM scale (QC2A80), and set the GALVO key (QC2A80) to its mid-position.
- (7) Subtract the reading obtained in sub-para. (3) from that obtained in sub-para. (6). The difference should be 1.5% to 2%.

#### R.P.M. low datum

15. (1) Set the SELECT METER TEST switch (QC2A80) to  $\emptyset 1$ .
- (1) Turn the SPEED SIGNAL COARSE control (QC2A80) slowly counter-clockwise until METER I (QC2A80) indicates 20V or less.
- (3) Set the DATUM SELECTOR switch (QC2A80) to LOW.
- (4) Set the SELECT METER TEST switch (QC2A80) to D.C. SOL., and adjust the SPEED SIGNAL FINE control (QC2A80) until METER I (QC2A80) indicates 225 mA.
- (5) Set the SPEED DATUM scale (QC2A80) to 90.2% .

**RESTRICTED**

(6) Carry out the procedure detailed in sub-para. 13 (13) and obtain a null on the galvanometer. Check that METER I (QC2A80) still indicates 225 mA.

(7) The reading on the SPEED DATUM scale should be  $90.2\% \pm 0.3\%$ . Set the GALVO key (QC2A80) to its mid-position.

(8) Set the DATUM SELECTOR switch (QC2A80) to HIGH., and set the SPEED SIGNAL COARSE and FINE controls (QC2A80) fully counter-clockwise.

(9) Switch the 28V d.c. supply OFF.

#### Disconnecting the test equipment

16. (1) Set the SELECT SPEED MEASUREMENT RANGE switch (QC2A80) to OFF.

(2) Switch off the 400 c/s supply.

(3) Turn the TEMP. and SPEED COARSE and FINE controls (QT223 and QC2A80) fully counter-clockwise.

(4) Set the TEMP. DATUM/OFF/TEMPERATURE DATUM & SIGNAL switch (QT223) to OFF.

(5) Clamp the two galvanometers.

(6) Disconnect the test cables and remove the QE2232 from the QT223.

**RESTRICTED**

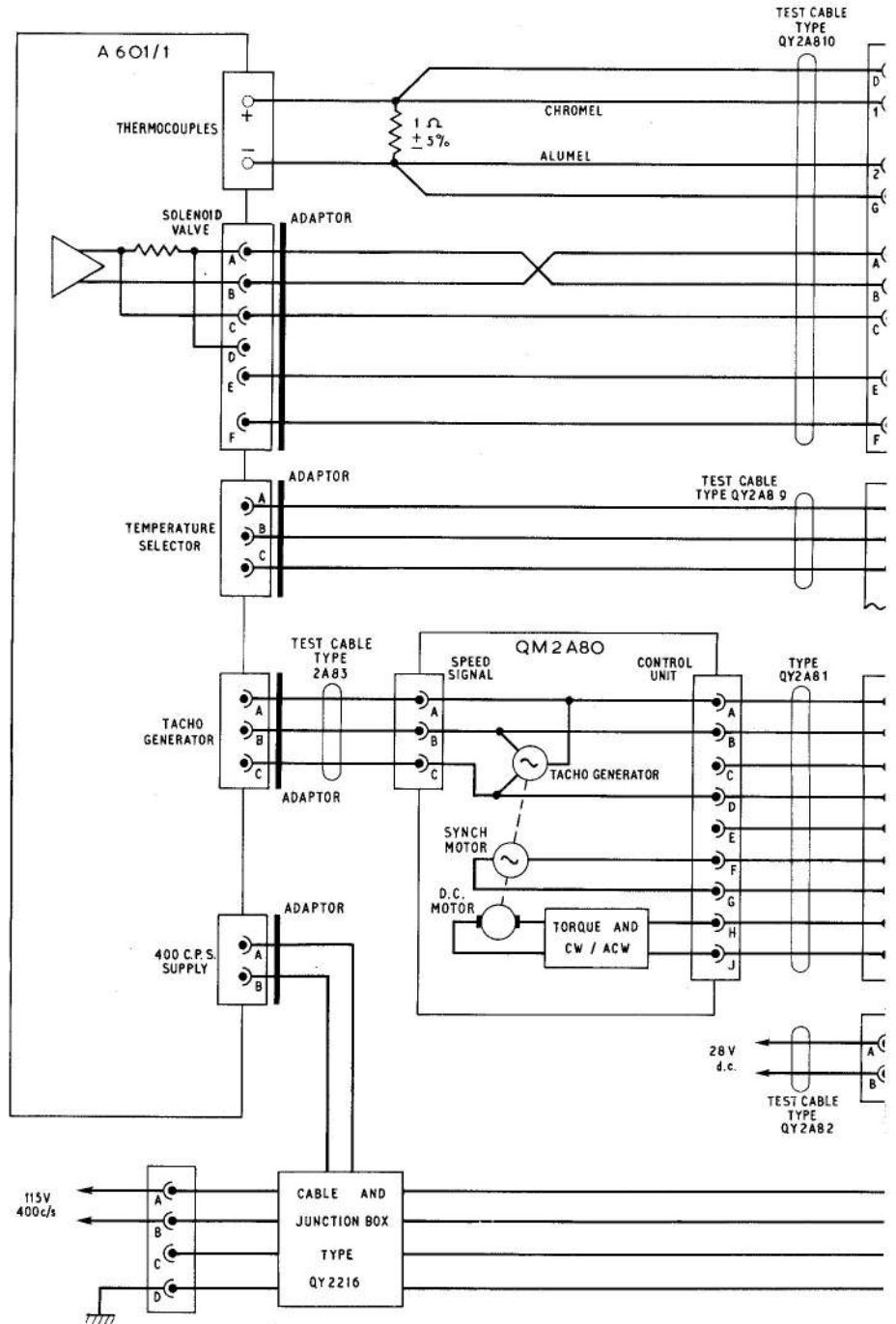
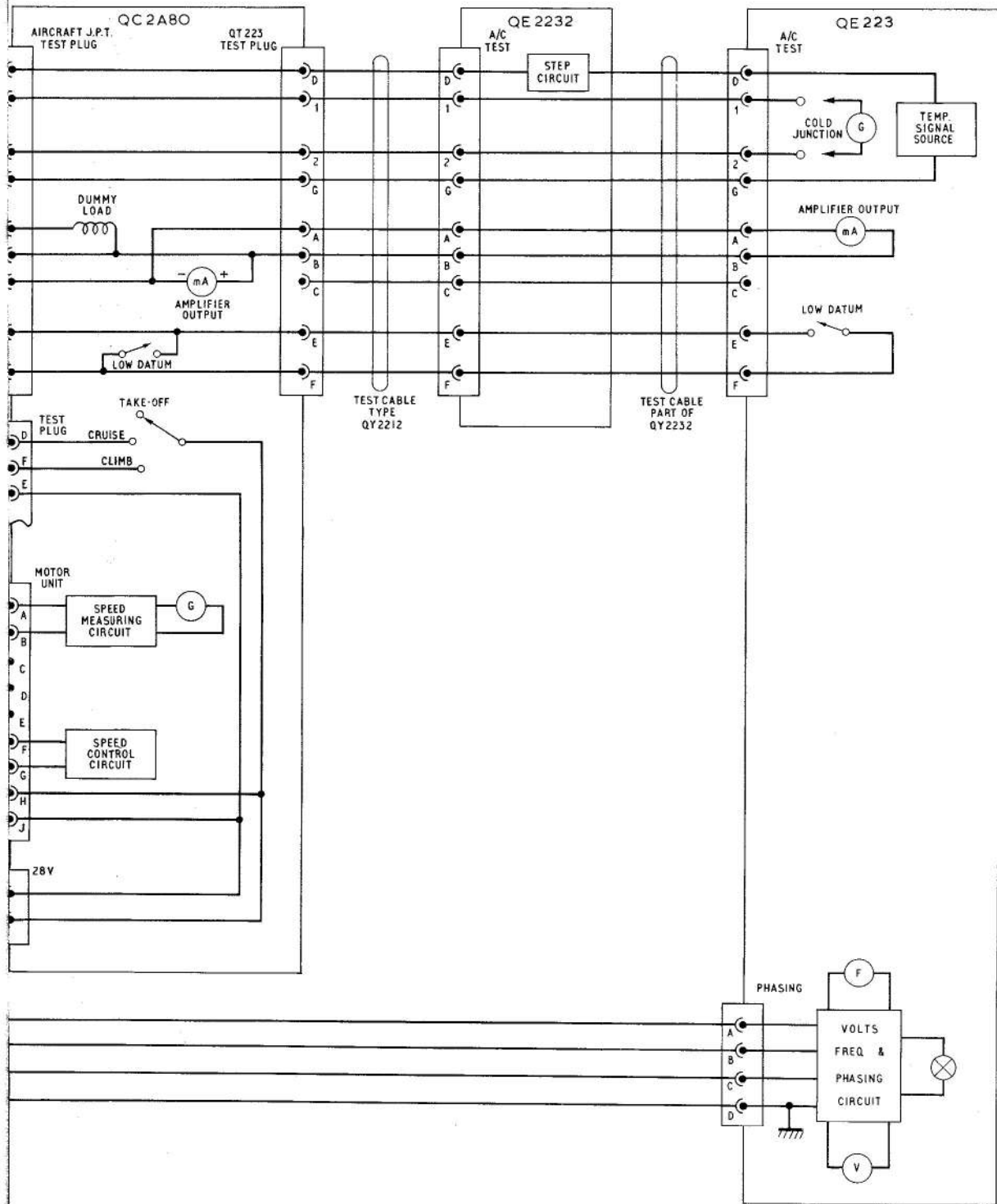

Fig. 1

Benc



h test connections  
**RESTRICTED**

**Fig. 1**

This file was downloaded  
from the RTFM Library.

Link: [www.scottbouch.com/rtfm](http://www.scottbouch.com/rtfm)

Please see site for usage terms,  
and more aircraft documents.

