

CHAPTER 1

ELECTRICAL SERVICES TEST CONSOLE

LIST OF CONTENTS

	<i>Para.</i>		<i>Para.</i>
<i>Introduction</i>	1	<i>Airbrakes and Main flaps</i>	23
DESCRIPTION			
Construction	3	<i>Heater Mats</i>	25
<i>Control panels</i>	9	<i>Contactors circuit test</i>	27
<i>Electrical supplies</i>	11	<i>Miscellaneous fire extinguishers</i>	29
<i>Extension looms</i>	18	<i>Auxiliary services test</i>	31
<i>Powered flying controls extension loom</i>	19	SERVICING	
Test circuits			
<i>Engine bay connections</i>	21	<i>Filament lamp replacement</i>	33
		<i>Periodic checks</i>	34

LIST OF ILLUSTRATIONS

	<i>Fig.</i>		<i>Fig.</i>
<i>General arrangement</i>	1	<i>Left hand control panel wiring diagram</i>	4
<i>Controls panels</i>	2	<i>Right hand control panel wiring diagram</i>	5
<i>Airbrakes and main flaps test set</i>	3		

LIST OF TABLES

	<i>Table</i>		<i>Table</i>
<i>Loom colour codings</i>	1	<i>Heater mat selections—Starboard</i>	3
<i>Heater mat selections—Port</i>	2	<i>Contactors test switch selections</i>	4

LIST OF APPENDICES

	<i>App.</i>		<i>App.</i>
<i>Schedule of tests</i>	1		
<i>Extension cable looms</i>	2	<i>Schedule of parts</i>	3

LEADING PARTICULARS

<i>Type</i>	80610P1
<i>Ref. No.</i>	26DE/95274
DIMENSIONS	
<i>Length</i>	31.5 in.
<i>Width</i>	24.5 in.
<i>Height (With wheels)</i>	46.5 in.
<i>Height (Without wheels)</i>	42.5 in.
<i>Weight</i>	185 lb.
<i>Supply voltages</i>	28 volts d.c. 112 volts d.c.

RESTRICTED

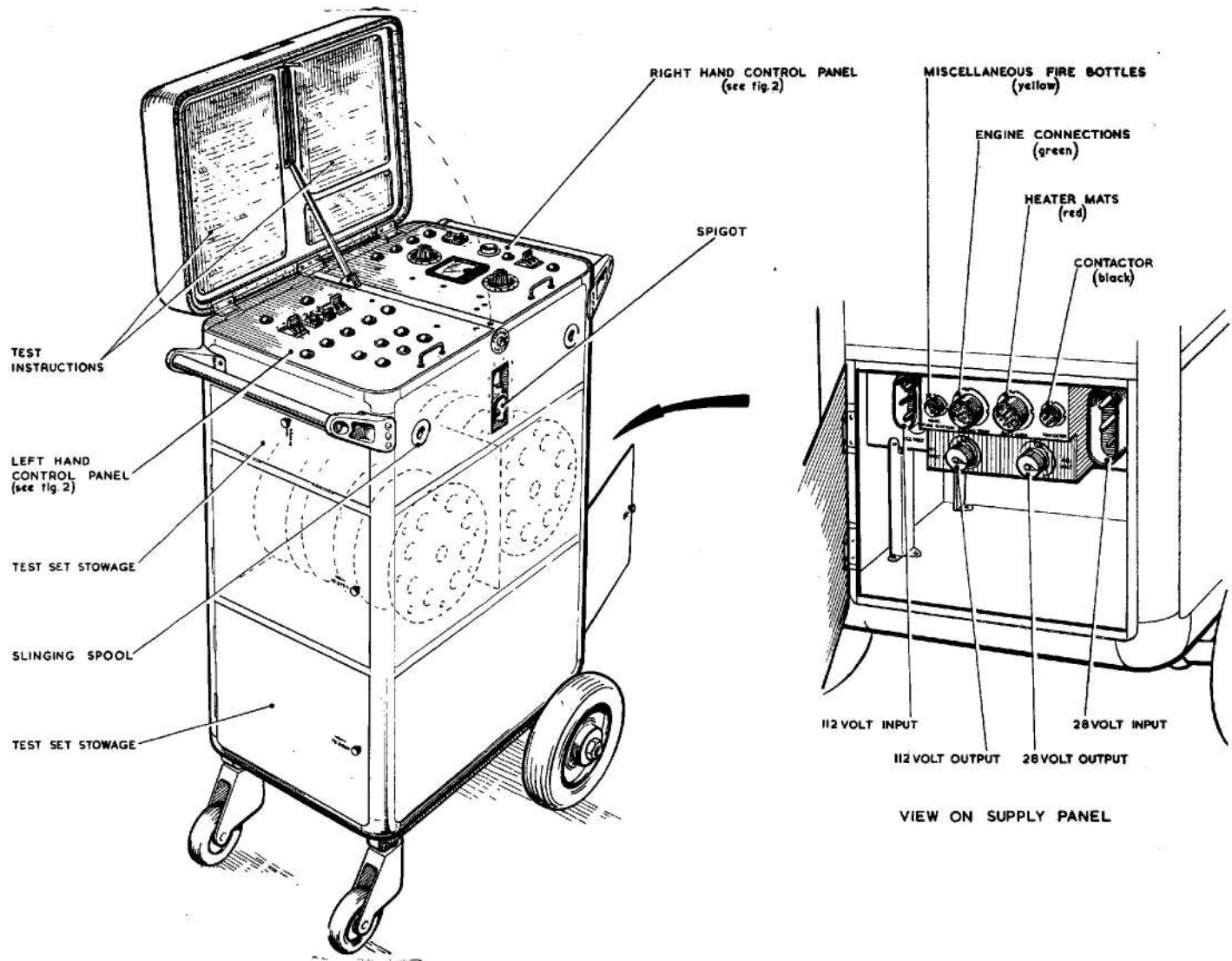

Fig. 1. General arrangement

Introduction

1. The transportable electrical test console, Ref. No. 26DE/95274, is designed to facilitate ground servicing on Victor B. Mk. 1 aircraft. Installations tested with this equipment comprise:— Engine bay connections, airbrakes and main flaps, heater mats, heater mat contactors and miscellaneous fire extinguishers. The console also provides

facilities for external tests with output supplies at 28 volts d.c. and 112 volts d.c.

2. This chapter contains descriptive and servicing information on the console and, where necessary, illustrations are provided. Operating instructions for use during a particular circuit test are given in Appendix 1.

DESCRIPTION

CONSTRUCTION

3. The test console, fig. 1, is of riveted light alloy construction built up from Widney Dorlec standard sections and sheet metal. It has two solid-tyred castoring wheels at the front and two fixed pneumatic-tyred wheels (pressurized to 15 lb./sq. in.) at the rear. The fitment of two tubular handles, one at each end, make the console fully manoeuvrable in confined spaces.

4. The body of the console is divided into four separate compartments; these are positioned vertically, one above the other. The lower three compartments are accessible through hinged doors forward and aft, whilst the top compartment is exposed on raising the hinge lid. To prevent the lid from inadvertently closing, there is a channelled locking strut which, on full extension, has a pin that automatically seats in grooves cut at the end of the channel.

Note . . .

The top of the console must not be used as a step as the lid is not strong enough for this purpose.

5. Within the top compartment there are two Tufnol control panels carrying switches, indicator lamps and meters associated with the test circuits. Some circuits do not use these controls; airbrakes and main flaps, for example, are tested by a subsidiary hand-held test set which can be stored within the console (*para. 23*).

6. The two lower compartments are subdivided into front and rear sections by a transverse diaphragm. Both sections of the uppermost of these compartments are used

to store drums of cable for use during testing operations. There are three drums in each section (*fig. 1*).

7. The rear section of the bottom compartment (*fig. 1*), has a fixed bracket on which are mounted four colour-coded connector plugs, input plugs for 28 volt and 112 volt, and two auxiliary output sockets providing 28 volt and 112 volt supplies. The front section of the bottom compartment provides storage space for the airbrake and main flaps hand-held test set.

8. For transportation and hoisting purposes, the console has four slinging spools, located one at each of the four corners, on the outside of the top compartment. The spools are normally flush mounted but may be extended by pulling the spool body along a housing built into the structure of console; each spool is retained in the housing by an 0.25 in. dia. B.S.F. bolt. Two retractable spigots, one on each side of the top compartment, are used for unreeling the drums of cable. The spigots are hinged at their base to fold flush into the sides of the console.

Control panels

9. The two control panels (*fig. 2*) in the top compartment are mounted side by side and are termed, respectively, left hand and right hand. The left hand panel carries the main switches, indicator lamps and circuit breakers for the 28 volt and 112 volt input and also the indicator lamps for starter motor, fuel and spill valves, ignition, H.P. cocks, engine fire extinguishers and miscellaneous fire extinguisher circuits. The right hand panel carries a SUPPLY ON circuit breaker and lamp, control switch and indicator lamps for test-

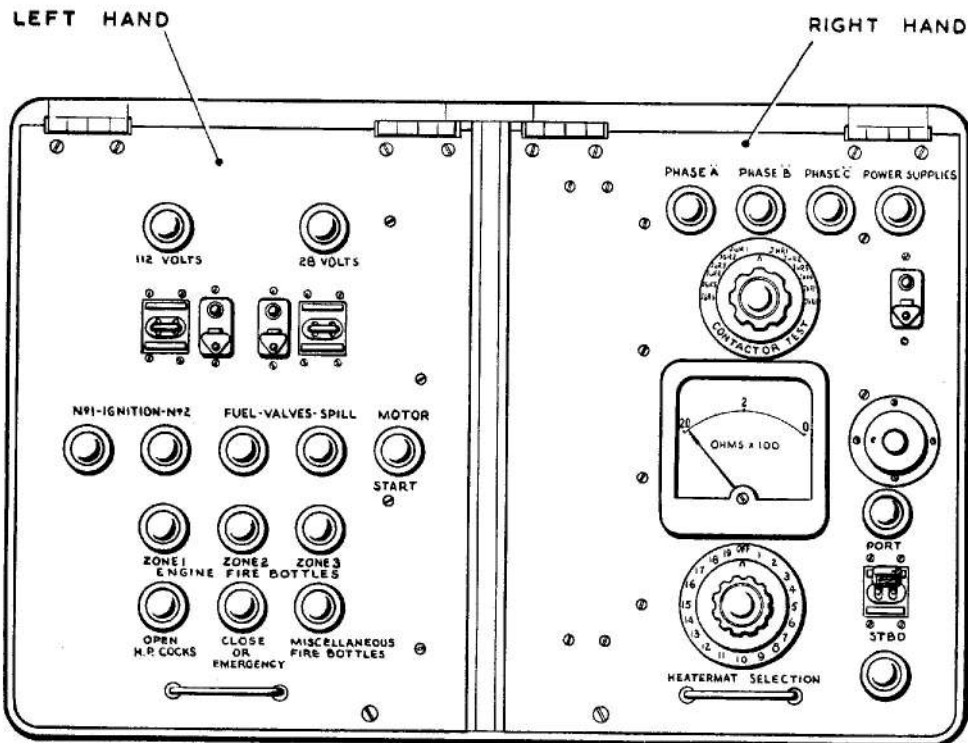

Fig. 2. Controls panels

ing port and starboard heater mat supplies, potentiometer, ohmmeter, mat selector switch, contactor selector switch and three phase lamps. On both panels each switch or lamp has its function clearly indicated in white paint.

10. On the reverse side of the control panels, which are secured in position by Dzus fasteners, are ten electro-magnetic relays, Type SM5/N33; two 20-way terminal blocks, Ref. No. 5X/3181; a 10-way terminal block, Ref. No. 5X/2863, and the wiring connections to the switch lamps and indicators. Each control panel can be hinged back into the open lid of the console when access to the wiring is necessary. When the lid is closed, weather protection for both control panels is by a rubber seal fitted round the periphery of the top compartment.

Electrical supplies

11. The 28 volt and 112 volt input supplies are obtained from the ground supply truck or other suitable source, and are connected to the console through the appropriate plug in the bottom compartment (fig. 1).

12. The 112 volt input (fig. 4) is routed to a 25 amp. circuit breaker, on the left hand control panel, which controls the supply to the 112 volt double pole control switch, Ref. No. 5CW/4199, and the 112 VOLT ON indicator lamp. The control switch is used to reverse the polarity of the supply to the 112 volt output socket and is provided as an extra test facility. Although the specification of the test console calls up the 112 volt supply, this supply is not used in connection with the test console circuits at present.

13. The 28 volt input (fig. 4) is routed along the inside of one of the upright frames of the console to terminal blocks below the control panels. These terminal blocks are numbered and function as distribution points for the supply. Terminal block No. 2, Ref. No. 5X/3181, is fitted below the left hand control panel and has ten terminals coded C1 to C10 (negative), and also ten coded D1 to D10 (positive). The input supply is connected to terminal D10 and connections are led away to a 15 amp. circuit breaker (from D9) for the 28 volt output socket, and to terminal block No. 3 (from D7) for the heater mats and contactor test circuits.

RESTRICTED

14. The 15 amp. circuit breaker, on the left hand control panel, connects the supply to terminal No. 2 of the 28 volt double pole control switch, Ref. No. 5CW/4199, and to the 28 VOLT ON indicator lamp; an earth for this supply is provided by terminal C9 on the 20-way terminal block (para. 13). The control switch is used to reverse the polarity of the supply to the 28 volt output socket.

15. Terminal block No. 3, Ref. No. 5X/2863, is fitted below the right hand control panel and has ten terminals coded from E1 to E10 (fig. 5). Terminals E1 to E5 are linked together and provide earthing facilities by their connection with terminal C7 on terminal block No. 2 (para. 13). Terminal E6 receives the 28 volt supply from terminal D7 and directs it to one side of a 5 amp circuit breaker on the right hand control panel. With this circuit breaker 'made', the supply is connected to terminals E7 to E10, which are linked together.

16. Terminals E7, E8, E9 and E10 distribute the supplies as follows:—

E7 A connection is taken from this terminal to illuminate the POWER SUPPLIES indicator lamp.

E8 Supplies the positive terminal of the ohmmeter and thence to terminal 1A of the heater mat rotary selector switch.

E9 Supplies terminal 'OA' of the heater mat rotary selector switch. With the switch selected to this position the supply is directed to terminal 2A of the contactor test rotary selector switch.

E10 Supplies the PORT/STBD. double pole selector switch, and this switch, when selected, routes the supply to either the PORT or STBD. indicator lamp. The port and starboard reference is used in conjunction

with tests on either the port or starboard side of the aircraft, i.e. by means of the appropriate test socket in aircraft distribution boards JG (port) or JE (starboard). In the PORT selection of the switch, console relay No. 7 is energized. This changes the direction of the output supply from pin X to pin R.

17. Certain of the test circuits, i.e. Engine bay connections, Miscellaneous fire extinguishers and Airbrakes and Main flaps do not require the console electrical supplies for test purposes. The console wiring for these installations is essentially to connect the indicator lamps in circuit, the energizing supply being taken from the aircraft L.V. supplies.

Extension looms

18. The drums of cable, para. 6, are used during testing operations to connect the aircraft to the console, or the hand-held test set as appropriate. Each drum has the cable formed into a loom, the ends of which are fitted with plugs or sockets to accord with the respective test point on the aircraft. For identification purposes, the loom sockets are colour-coded and, at the console, they are connected to similarly coloured plugs in the power compartment of the console. The loom colour codes are given in Table 1; the composition of each loom is given in Appendix 2.

Powered flying controls extension loom

19. Prior to the introduction of Victor B. Mk. 1 Mod. 318, which connects all electrical wiring to the powered flying control unit through a common plug and socket mounted on the valve block housing, it is necessary, during testing operations, to extend the aircraft loom. An extension loom is provided on the console for this purpose.

TABLE 1
Loom colour codings

Colour	Function
Yellow	Console—Miscellaneous fire extinguishers
Green	Console—Engine bay connections
Red	Console—Heater mats and contactors
Black	Console—Heater mats and contactors
White	Test set—Airbrake and main flaps
Blue	Powered flying controls extension loom—pre. mod. 318

20. In addition to the extension looms a shorting link is also provided for use when checking the engine bay connections. The shorting link is stowed in a clip provided on the inner face of the access door to the front section of the bottom compartment.

TEST CIRCUITS

Engine bay connections

21. The console is designed to test engine control functions when an engine (any one) has been removed from the aircraft. For this test, the left-hand control panel, the shorting link and the loom colour-coded green are used. The left hand control panel has warning lamps for:— Starter motor, fuel and spill valves, ignition, H.P. cocks and the fire extinguishers in Zones 1, 2 and 3. These are connected through terminal block coded No. 1 to the 25-pin fixed plug, Ref. No. Z560201, in the front section of the bottom compartment. The 'Green' loom has, at the engine bay end, eight free plugs and two ferruled lugs; these are connected to the associated engine bay terminations (*Appendix 2, Table 1*).

22. Electrical power supplies for operation of the lamps on the left hand control panel are derived from the aircraft circuits. Control over the circuit is by the engine controls in the aircraft which, when an engine start control is operated, will cause the test console lamps to operate in sequence. Test instructions for the engine bay connections are given in *Appendix 1, Schedule 1*.

Airbrakes and Main flaps

23. The airbrakes and main flaps are tested with the appropriate hand held test set (*fig. 3*); this is stored in the rear section of the bottom compartment. The test set contains two lamps, one amber and the other red, a double pole change-over switch and a six-pin fixed plug colour-coded white. The 'White' loom has one end connected to this plug; the other end of the loom is connected to the aircraft selector and the aircraft wiring (*Appendix 2, Table 6*).

24. Electrical supplies to permit the test to be made are derived from the aircraft circuits and, except for the double pole switch on the test set, are controlled from the aircraft. Instructions on testing are given in *Appendix 1, and Schedule 2*. They are also engraved on the upper face of the test set.

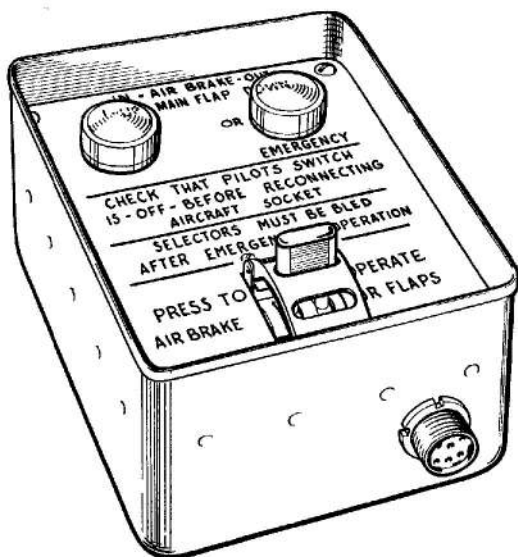
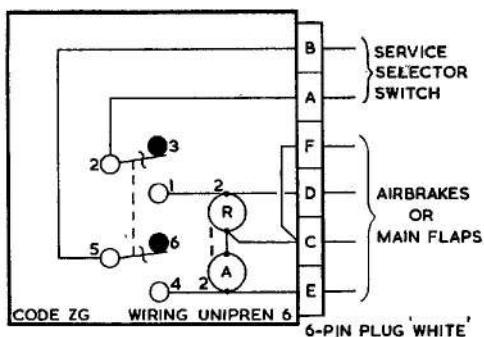

Fig. 3. Airbrakes and main flaps test set

Heater mats

25. Certain areas on the aircraft have electrically heated, resistance type elements fitted. These are tested by checking the resistance obtained from a particular heater against known values; these are given in *Tables 2 and 3*. Testing instructions are given in *Appendix 1, Schedule 3*.

26. Normally, the heater mats are supplied with 208 volt, variable frequency a.c. power but, for test purposes, the console 28 volt d.c. supply is used. This is directed to individual heaters by operating the rotary switch (*para. 16*) on the right hand control panel, through positions engraved 1-19 (*Table 2 and 3*). The test console is connected in the heater mats

RESTRICTED

circuits through the loom colour-coded red and a 25-way test socket (on distribution boards JG, port, and JH, starboard) as required.

Contactors circuit test

27. The contactors circuit test is associated with the heater mats tests, as the contactors tested are those which connect the aircraft a.c. supplies to the heater elements. The object of the test is to prove their operation by illuminating three 'phase lamps' on the right hand control panel; the lamps are marked A, B and C to accord with the normal coding of the aircraft a.c. supply.

28. Supplies to the contactor rotary selector are taken from terminal block No. 3 (*para.* 16) and are controlled by the 5 amp circuit breaker and position No. 0 of the heater mat rotary selector. When the contactor switch is selected to any of the marked aircraft contactors, the supply is routed to energize the control coil of the appropriate console relay (*Table 4*). In addition, a connection from the selector switch is routed through the 'black' loom and test socket on distribution board JG or JH to the aircraft 208 volt a.c. bus-bars. Contactors on boards JG and JH are operated from the aircraft and, when the appropriate contactor is selected, the closure of its contacts connects the 28 volt supply through the 'red' loom and console relays to illuminate the console phase lamps. Testing instructions are given in Appendix 1, Schedule 4.

32. Apart from periodic checks on the condition of all connections, relays, instruments, lamps and switches the test console should require little servicing.

Filament lamp replacement

33. When it is necessary to replace a filament lamp proceed as follows:—

- (1) Remove the lamp cover and unclip the control panels.
- (2) Raise the respective control panel and, on the underside, locate the lamp where the filament has failed.

Miscellaneous fire extinguishers

29. This circuit is used to test all electrically discharged fire extinguishers on the aircraft except those in the engine bays or those operated by 'Firewire' elements. The respective extinguishers are electrically disconnected and the connecting plug fitted into the free socket of the 'yellow' loom. At its other end the loom is connected to the appropriately coloured plug on the console which, in turn, is connected to the test lamp on the left hand control panel.

30. Electrical power supplies for operation of the test lamp are derived from the aircraft circuit. Control over the operation of the circuit is by the normal aircraft fire extinguisher controls. Testing instructions are given in Appendix 1, Schedule 5.

Note . . .

Certain fire extinguishers are connected together in series. During circuit test operations it is essential that ALL fire extinguishers, except those being tested, are disconnected from the aircraft electrical supplies.

Auxiliary services test

31. The front section of the bottom compartment contains two sockets; these are for 28 volt and 112 volt extra test facilities respectively. No looms or test instructions are provided for the sockets since it is for the users to connect fittings and cables appropriate to the equipment to be tested. However, all precautions consistent with the potential hazards of any proposed test must be observed.

SERVICING

(3) Push the lamp holder along its slide until the filament lamp protrudes from the topside of the control panel.

(4) Remove the unserviceable filament lamp and replace with a serviceable lamp, Ref. No. 5L/9953202.

Note . . .

Three spare filament lamps are contained in a storage below the left hand control panel.

(5) Withdraw the lamp holder into the slide.

(6) Replace the control panel and lamp cover.

Periodic checks

34. The following periodic checks are recommended:—

(1) Ensure the pneumatic tyres are correctly inflated to 15 lb./sq. in. at all times.

(2) Keep the looms free from oil, grease, dirt and damage.

(3) When not in use, ensure looms are correctly coiled and stored.

(4) Ensure all mechanical moving parts are lubricated.

TABLE 2

Heater mat selections—Port

Selection	Loom Pin	Supplies	Ohm Resistance
OFF	—	Contactors test switch	—
1	—	Earth at terminal E3	—
2	F	Port boundary layer heater, cable Y	5-6
3	E	Port boundary layer heater, cable B	5-6
4	D	Port boundary layer heater, cable R	5-6
5	A	Port saddle heater, cable R	17-20
6	B	Port saddle heater, cable B	17-20
7	C	Port saddle heater, cable Y	17-20
8	G	Port splitter heater	22-26
9	H	Port nostril heater	39-44
10	W	Not used	—
11	V	Zone 3 outer engines	39-45
12	R	Heaters on battery access door	60-69
13	Q	Heaters under battery shelf	40-46
14	P	Heaters on undercarriage bay wall	60-69
15	O	Zone 2 outer engine heater	39-45
16	N	Zone 2 inner engine heater	39-45
17	M	Zone 3 inner engine heater	39-45
18	L	Aileron power unit heater	18-21
19	J	Alternator cooling duct heater and wing jet pump splitter	35-41

TABLE 3

Heater mat selections—Starboard

Selection	Loom Pin	Supplies	Ohm Resistance
OFF	—	Contactors test switch	—
1	—	Earth terminal E3	—
2	F	Stbd. boundary layer heater, cable Y	5-6
3	E	Stbd. boundary layer heater, cable B	5-6
4	D	Stbd. boundary layer heater, cable R	5-6

RESTRICTED

TABLE 3 (continued)
Heater mat selections—Starboard

Selection	Loom Pin	Supplies	Ohm Resistance
5	A	Stbd. saddle heater, cable R	17-20
6	B	Stbd. saddle heater, cable B	17-20
7	C	Stbd. saddle heater, cable Y	17-20
8	G	Stbd. nostril heater	38-44
9	H	Stbd. splitter heater	60-70
10	W	Elevator feel simulator heaters	153-179
11	V	Rudder feel simulator heaters	153-179
12	X	Aileron and elevator feel simulator heaters	153-179
13	Q	Rudder power unit splitter and Zone 3 outer engine	36-42
14	P	Pitot head heater	27-32
15	O	Zone 2 outer engine heater	39-45
16	N	Zone 2 inner engine heater	39-45
17	M	Zone 3 inner engine heater	39-45
18	L	Aileron power unit heater	18-21
19	J	Alternator cooling duct heater and wing jet pump splitter	35-41

TABLE 4
Contactor test switch selections

Selection	Console Relay	Aircraft contactor energizing supply	Aircraft control S/W
JHR1	2	Board JD 28v. supply	Test s/w—board AJ
JHR2	3	Board JD 28v. supply	Test s/w—board AJ
JHR3	5	Board JD 28v. supply	Test s/w—board AJ
JHR4	6	Board JD 28v. supply	Test s/w—board AJ
JHR7	4	Board AJ 28v. supply	*Port pitot—panel AZ
JHR11	1	Board JD 28v. supply	Test s/w—board AJ
JGR1	2	Board JD 28v. supply	Test s/w—board AJ
JGR2	8	Board JD 28v. supply	Test s/w—board AJ
JGR3	9	Board JD 28v. supply	Test s/w—board AJ
JGR4	6	Board JD 28v. supply	Test s/w—board AJ
JGR5	10	L.V. battery supplies	*Stbd. battery s/w panel BB
JGR11	1	Board JD 28v. supply	Test s/w—board AJ

* Supplies routed through a thermal switch



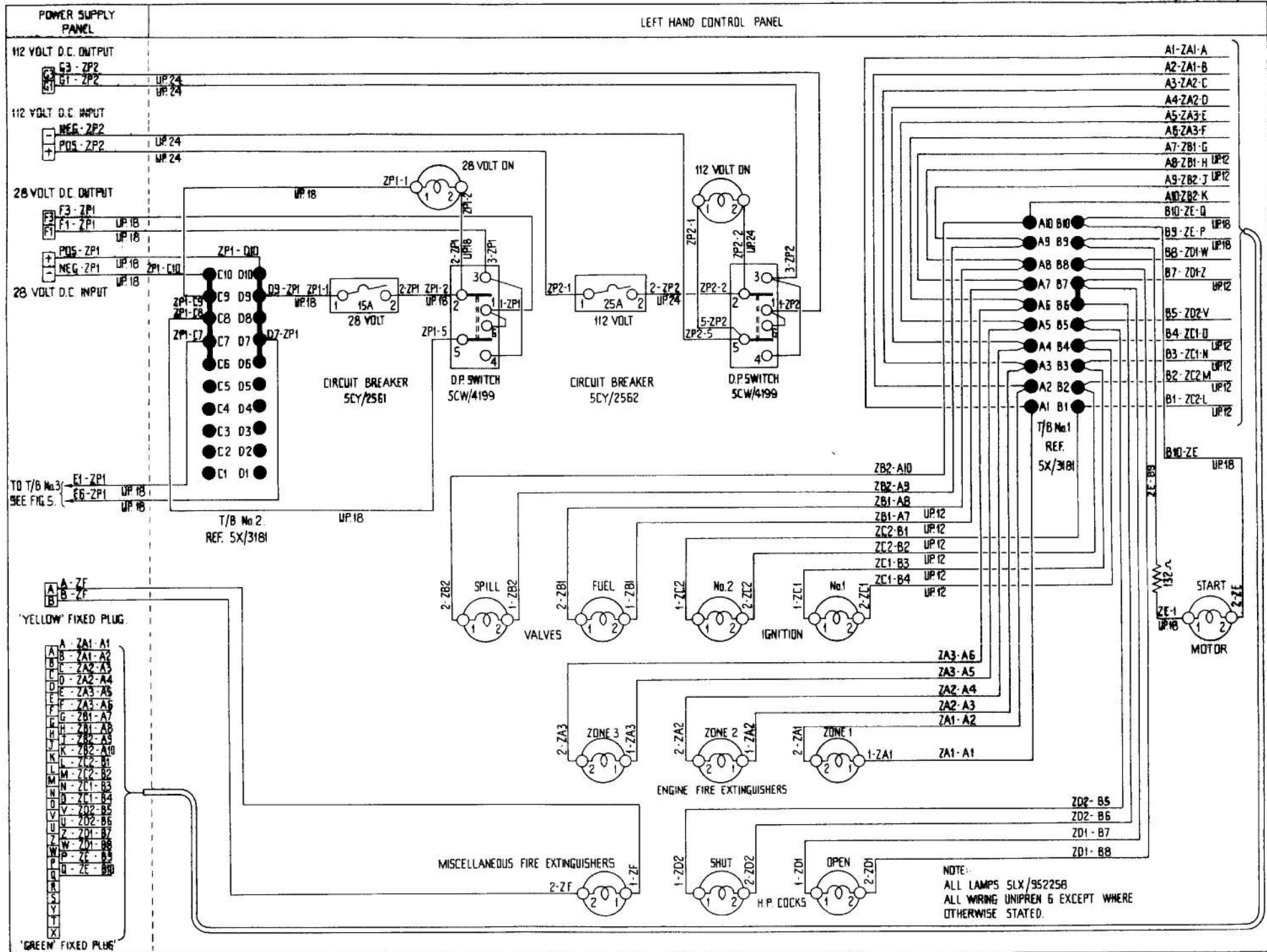

Fig.4. Left hand control panel wiring diagram

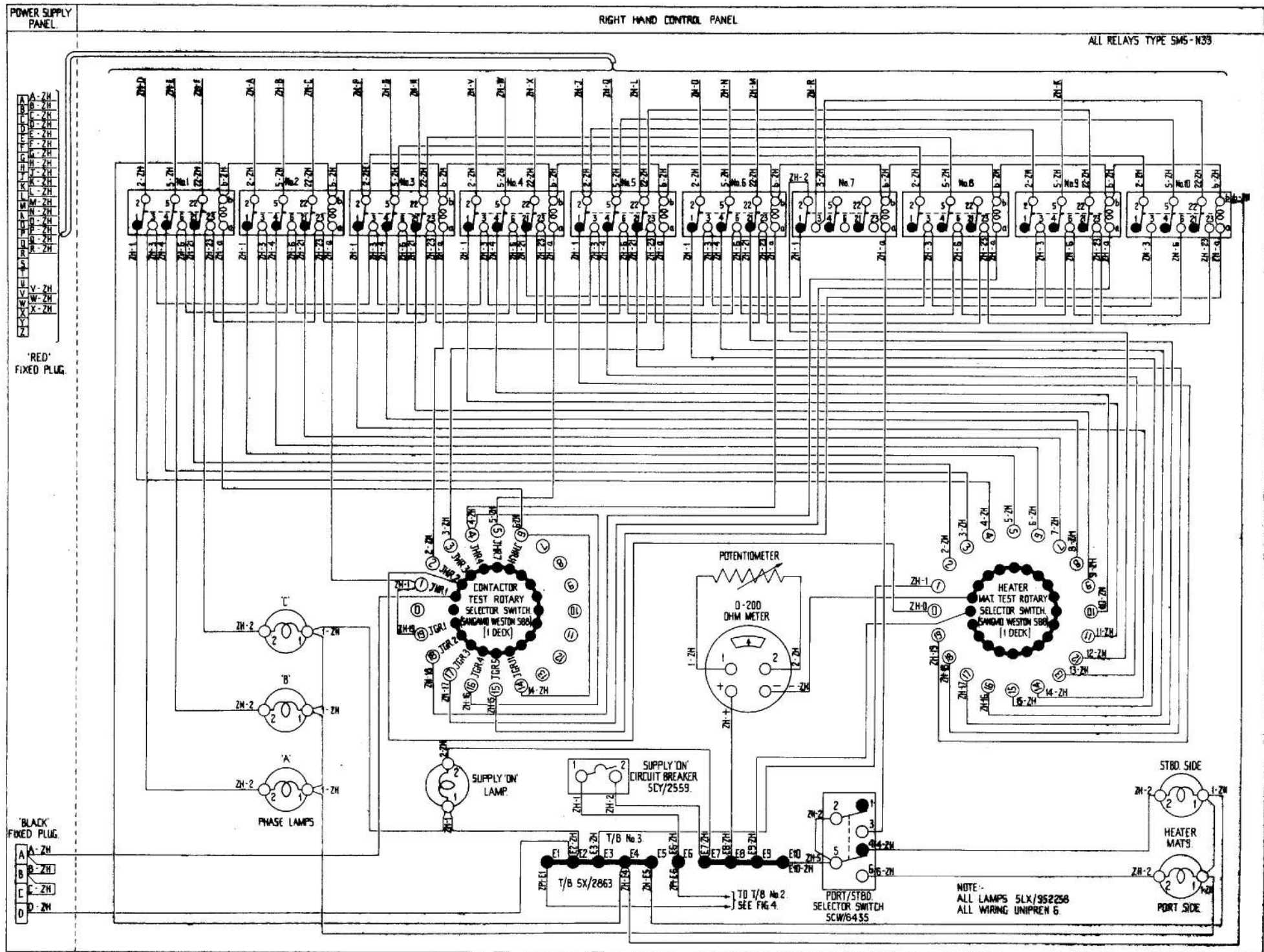

Fig. 5. Right hand control panel wiring diagram

APPENDIX 1

SCHEDULE OF TESTS (Aircraft systems)

LIST OF CONTENTS

	<i>Schedule</i>		<i>Schedule</i>
<i>Engine bay connections</i>	1	<i>Contactor test</i>	4
<i>Airbrakes and main flaps</i>	2	<i>Miscellaneous fire extinguishers</i> ...	5
<i>Heater mats</i>	3	<i>Auxiliary 28v. and 112v. d.c. supplies</i>	6

SCHEDULE 1—ENGINE BAY CONNECTIONS

(a) Introduction

(1) It is possible to test the engine bay connections and make a simulated engine start even with the engine removed from the aircraft engine bay. The starting sequence of operations is shown by indicator lamps on the left hand panel of the console. This circuit employs the loom colour-coded green.

(b) Pre-test requirements

- (1) Position the test console below the engine bay.
- (2) Ensure that the aircraft electrical power supplies are switched 'OFF'.
- (3) Connect the 'green' loom to the 'green' plug on the console.
- (4) Disconnect the fire extinguishers in Zones 1, 2 and 3, and connect the appropriate loom plugs to the aircraft fire extinguisher sockets.
- (5) Disconnect the fuel and spill valves, H.P. cock and ignition units and connect the appropriate loom plugs to the aircraft sockets.
- (6) Disconnect the starter motor and connect loom leads +VE and -VE to the respective aircraft leads, i.e. +VE to +VE and -VE to -VE.

Note . . .

Ensure that the leads are not in contact with the aircraft structure or servicing equipment.

- (7) 'Short out' the overspeed relay contacts with the shorting link provided on the console.

(8) Ensure:—

Alternator switches	OFF
Motor-ignition isolation switches	ON
Engine start circuit breaker	Made
H.P. cock circuit breaker	Made
Engine fire warning circuit breaker	Made
Starter Master switch	GROUND

(c) Test procedure

- (1) Switch aircraft 28v. and 112v. supplies ON.
- (2) Select the appropriate engine on the engine selector switch.
- (3) Press the starter button. This causes the starter lamp on the console to be illuminated and remain on for 30 seconds. When the light goes out pull the starter button OUT.
- (4) The fuel valve, spill valve and the two ignition lamps on the console are illuminated for 3 seconds after the starter lamp.
- (5) Open the throttle. This extinguishes the H.P. cock CLOSED lamp and illuminates the OPEN lamp.
- (6) Press the appropriate engine fire extinguisher switches. This switches off the H.P. cock OPEN lamp and illuminates the CLOSED lamp. Also, the fire warning lamps for zones 1, 2 and 3 are illuminated.
- (7) 'Trip' the fire warning and engine start circuit breakers (A.P.4506A, Vol. 1, Book 2) and then press the engine relight button at the pilot's position. This causes the ignition lamp and fuel valve lamp, on the console, to illuminate.

- (8) Close the throttle.
- (9) Repeat test 1-8 on the other engines.

(d) After test

- (1) Switch OFF the power supplies and disconnect the console.

- (2) Reconnect engine services.

- (3) Ensure that the starting link is removed from the overspeed relay.

SCHEDULE 2—AIRBRAKES AND MAIN FLAPS

(a) Introduction

- (1) The airbrakes and main flaps are tested with the appropriate hand-held test set. The test employs the loom coloured white.

(b) Pre-test requirements

- (1) Position the test console by the aircraft.
- (2) Ensure the aircraft's 28v. and 112v. supplies are switched OFF.
- (3) Connect the loom to hand-held test set
- (4) Remove the socket from the normal selector and connect the loom to the aircraft socket and cylinder.

(c) Test procedure

- (1) Switch on the aircraft supplies.
- (2) Ensure hydraulic pumps are running.

- (3) Select airbrakes out and press switch on test circuit. The appropriate light will go out when the airbrakes have reached the limit of travel. Repeat in reverse direction.

- (4) Repeat for emergency selection.

- (5) The airbrake position indicator is tested by ensuring that the indicator corresponds to the position of the airbrakes while the test is in progress.

(d) After test

- (1) Switch OFF the supplies at the pilot's stations and re-connect the aircraft socket to the selector.
- (2) Bleed the emergency selector after it has been operated.

(e) Main flaps

- (1) The main flaps are tested similarly to the airbrakes.

SCHEDULE 3—HEATER MATS

(a) Introduction

- (1) The console is used to test the electrically heated surfaces on the aircraft. All controls necessary for testing are mounted on the right hand control panel of the console.

- (2) The loom coloured red is used on this test.

(b) Pre-test requirements

- (1) Position the console adjacent to the plenum chamber access door.
- (2) Connect the 'Red' loom between the test console and the respective test socket in either distribution board JG or JH.

(c) Test procedure

- (1) With the loom connected to distribu-

tion board JG select the console change-over switch to port.

- (2) Select the heater mat switch to OFF.

- (3) Select the 28v. supply to the console and close the 5 amp circuit breaker on the right hand panel.

- (4) Select contactor test switch to OFF.

- (5) Select the required heater mat on the selector switch and read off the ohmmeter.

- (6) Compare the value obtained with the values given in Tables 2 and 3.

- (7) Repeat the above tests for the other distribution board selecting the change-over switch to starboard.

(d) After test

- (1) Switch OFF the electrical supplies.
- (2) Disconnect the looms and store.

RESTRICTED

SCHEDULE 4—CONTACTOR TEST

(a) Introduction

- (1) The operation of the aircraft three phase contactors is proved by this test. The looms coloured red and black are used.

(b) Pre-test requirements

- (1) Position the test console adjacent to the plenum chamber.
- (2) Connect the appropriate looms to the console.
- (3) Select change-over switch to port.
- (4) Select the heater mat switch OFF.
- (5) Connect the 28v. supply to the console and close the 5 amp circuit breaker on the right hand control panel.

(c) Test procedure

- (1) Switch ON the aircraft's 28v. supply.
- (2) Operate the anti-icing controls in the cabin to close contactors in board JG and JH.
- (3) Select the contactor required on the console selector switch. If the aircraft contactors are serviceable, the three-phase lamps A, B and C, on the console, will light up for each contactor in turn.
- (4) Repeat the above test for distribution board JH, after selecting the change-over switch to starboard.

(d) After test

- (1) Switch OFF the console and aircraft supplies.
- (2) Disconnect the loom and store.

SCHEDULE 5—MISCELLANEOUS FIRE EXTINGUISHERS

(a) Introduction

- (1) The miscellaneous fire bottles comprise all electrically operated extinguishers fitted to the aircraft apart from those in each engine bay. The circuit for each is tested individually.

(b) Pre-test requirements

- (1) Position the console adjacent to the bottle being tested.
- (2) Connect the 'yellow' loom to the console.
- (3) Unreel the loom.
- (4) Disconnect all the electrically operated miscellaneous fire extinguishers.
- (5) Connect the loom plug to the electrical socket of the fire extinguisher to be tested.

- (6) Switch ON the aircraft 28v. d.c. electrical supply.

(c) Test procedure

- (1) Depress the appropriate fire-push switch. If the aircraft electrical circuit is serviceable the console lamp will illuminate.
- (2) Repeat the above procedure for the other fire extinguishers.

(d) After test

- (1) Switch OFF the aircraft 28v. d.c. supply.
- (2) Reconnect all the miscellaneous fire extinguishers.
- (3) Disconnect the console loom and store.

SCHEDULE 6—AUXILIARY 28V. AND 112V. D.C. SUPPLIES

The 28v. and 112v. d.c. outlets on the console are controlled by the respective circuit breakers for testing external equipment. These two outlets have reversible polarity

controlled by the two change-over switches. All testing with the console auxiliary supplies must comply with fully approved procedure.



APPENDIX 2

EXTENSION CABLE LOOMS

LIST OF CONTENTS

	<i>Table</i>		<i>Table</i>
<i>Extension cable loom—Green ...</i>	... 1	<i>Extension cable loom—Yellow ...</i>	... 4
<i>Extension cable loom—Red ...</i>	... 2	<i>Extension cable loom—P.F.C. ...</i>	... 5
<i>Extension cable loom—Black ...</i>	... 3	<i>Extension cable loom—White ...</i>	... 6

TABLE 1

Extension cable loom—Green

Part No.	Size	Termination				Aircraft	Connection
		Sleeve	Console	Sleeve			
802453K2	UP12	A-ZA1	Mk. 4 Free Socket Z.560221, 25 Pin	ZA1-A	5X/6001	Zone 1 fire extinguisher	
802453K3	UP12	B-ZA1		ZA1-B			
802453K4	UP12	C-ZA2		ZA2-A	5X/6001	Zone 2 fire extinguisher	
802453K5	UP12	D-ZA2		ZA2-B			
802453K6	UP12	E-ZA3		ZA3-A	5X/6001	Zone 3 fire extinguisher	
802453K7	UP12	F-ZA3		ZA3-B			
802453K8	UP12	G-ZB1		ZB1-A	5X/6006	Fuel valve	
802453K9	UP12	H-ZB1		ZB1-B			
802453K10	UP12	J-ZB2		ZB2-C	5X/6001	Spill valve	
802453K11	UP12	K-ZB2		ZB2-D			
802453K12	UP12	L-ZC2		ZC2-A	5X/6001	No. 2 ignition	
802453K13	UP12	M-ZC2		ZC2-B			
802453K14	UP12	N-ZC1		ZC1-A	5X/6001	No. 1 ignition	
802453K15	UP12	O-ZC1		ZC1-B			
802453K16	UP18	P-ZE		ZE-Relay	5H/40	Starter motor	
802453K17	UP18	Q-ZE		ZE-Earth	5H/40		
802453K18	UP12	S-ZD		ZD-4	5X/6379	H.P. fuel cocks	
802453K19	UP12	T-ZD		ZD-3			
802453K20	UP12	U-ZD2		ZD2-1	5X/6036	H.P. fuel cocks	
802453K21	UP12	Y-ZD2		ZD2-7			
802453K22	UP12	W-ZD1		ZD1-6	5X/6036	H.P. fuel cocks	
802453K23	UP12	X-ZD		ZD-3			
802453K24	UP12	Y-ZD		ZD-4	5X/6036	H.P. fuel cocks	
802453K25	UP12	Z-ZD1		ZD1-1			

TABLE 2
Extension cable loom—Red

Part No.	Size	Termination				
		Sleeve	Console	Sleeve	Aircraft	Connection
802458K2	UP12	A-ZH	Mk. 4 Free Socket, Z.560220, 25 Pin	ZH-A	Mk. 4 Free Plug, Z.560400, 25 Pin	Test socket in either distribu- tion board JG or JH
802458K3	UP12	B-ZH		ZH-B		
802458K4	UP12	C-ZH		ZH-C		
802458K5	UP12	D-ZH		ZH-D		
802458K6	UP12	E-ZH		ZH-E		
802458K7	UP12	F-ZH		ZH-F		
802458K8	UP12	G-ZH		ZH-G		
802458K9	UP12	H-ZH		ZH-H		
802458K10	UP12	I-ZH		ZH-I		
802458K11	UP12	J-ZH		ZH-J		
802458K12	UP12	K-ZH		ZH-K		
802458K12	UP12	L-ZH		ZH-L		
802458K13	UP12	M-ZH		ZH-M		
802458K14	UP12	N-ZH		ZH-N		
802458K15	UP12	O-ZH		ZH-O		
802458K16	UP12	P-ZH		ZH-P		
802458K17	UP12	Q-ZH		ZH-Q		
802458K18	UP12	R-ZH		ZH-R		
802458K19	UP12	S-ZH		ZH-S		
802458K20	UP12	T-ZH		ZH-T		
802458K21	UP12	U-ZH		ZH-U		
802458K22	UP12	V-ZH		ZH-V		
802458K23	UP12	W-ZH		ZH-W		
802458K24	UP12	X-ZH		ZH-X		
802458K25	UP12	Y-ZH		ZH-Y		
802458K26	UP12	Z-ZH		ZH-Z		

TABLE 3
Extension Cable loom—Black

Part No.	Size	Termination				
		Sleeve	Console	Sleeve	Aircraft	Connection
802459K2	UP12	A-ZH	Mk. 4 Free Socket Z.560160 4-Pin	ZH-A	Mk. 4 free plug Z.560360 12-pin	Test socket in either distribu- tion board JG or JH
802459K3	UP12	B-ZH		ZH-B		
802459K4	UP12	C-ZH		ZH-C		
802459K5	UP12	D-ZH		ZH-D		

RESTRICTED

TABLE 4

Extension cable loom—Yellow

Part No.	Size	Termination			Aircraft	Connection
		Sleeve	Console	Sleeve		
802454K2 802454K3	Uniflex- Pren 6	A-ZF	Mk. 4 Free Socket Z.560090 2-pin	ZF-A	Single plug 5X/6001 2-pin	Miscellaneous fire extinguishers
		B-ZF		ZF-B		

TABLE 5

Extension cable loom—Powered flying controls

Part No.	Size	Termination			End ' B '	Length
		Sleeve	End ' A '	Sleeve		
802460K2 802460K3 802460K4 802460K5 802460K6 802460K7 802460K8 802460K9	Uniflex- pren 6	A-ZJ	Socket 5X/6781	ZJ-A	Plug 5X/6091	2.5 ft.
		B-ZJ		ZJ-B		2.5 ft.
		C-ZJ		ZJ-C		2.5 ft.
		D-ZJ		ZJ-D		2.5 ft.
		G-ZJ		ZJ-G		2.5 ft.
		H-ZJ		ZJ-H		2.5 ft.
		J-ZJ		ZJ-J		2.5 ft.
		K-ZJ		ZJ-K		2.5 ft.

TABLE 6

Extension cable loom—White

Part No.	Size	Termination			Test Set	Connection	
		Sleeve	Test Set	Sleeve			
802451K2 802451K3 802451K4 802451K5 802451K6 802451K7	Uniflex pren 6	A-ZG	Mk. 4 Breeze Socket Z.560120 6-pin	ZG-A	5X/6799	Aircraft selec- tor	
		B-ZG		ZG-B			
		C-ZG		ZG-C			
		D-ZG		ZG-D		5X/6179	Aircraft cable
		E-ZG		ZG-E			
		F-ZG		ZG-F			

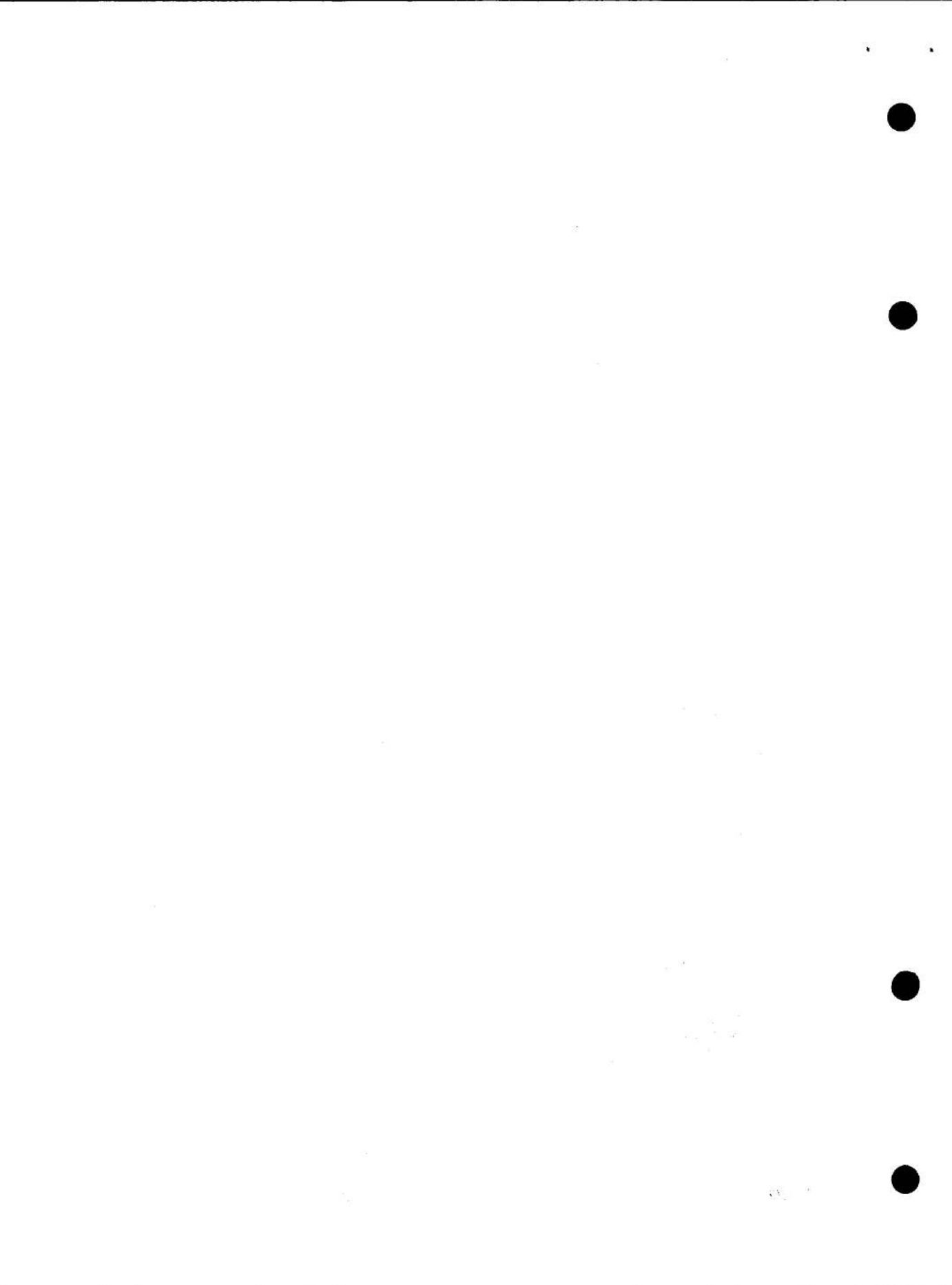

APPENDIX 3

SCHEDULE OF PARTS

Ref No.	Part No.	Description	Qty.	Manufacturer, Spec. Material, Etc.
26DE/95274	80610P1	Console, electrical services ground test, Spares for:—	1	Handley Page
	80610P32	Axle	1	S.1
	80620P4	Bar, check for lid	1	
26DE/95319	80549P1	Box, test, airbrake and flaps, Group, Spares for:—	1	
	80549P5	Handle	1	Leather
	80549P7	Panel, Group, Spares for:—	1	
5CX/-		Lamp, signal	1	Bulgin
5CX/-		Lamp, signal	1	Bulgin
	80549P8	Panel, bare	1	Perspex
5CW/4225		Switch, double pole	1	
	CZ.49223	Socket, miniature 6-way	1	Plessey
	80576P1	Bracket, for plugs	1	
	80615P12	Button, push for lid catch	1	S.1
	No. 8623	Castor	2	Slingsby
	80610P35	Chain, check for top doors	4	
5CY/4314		Connector, 28 volt d.c.	1	
5CY/4315		Connector, 112 volt d.c.	1	
	80612P1	Door, centre c/w catch	2	
	80613P1	Door, lower c/w catch	2	
	80632P1	Door, top c/w catch	2	
	80604P1	Drum, cable "green" group	1	
	80604P2	Drum, cable "red, white, black, blue" group	4	
	80604P3	Drum, cable "yellow" group	1	
		Spares for:—		
	80604P5	Bush, bearing	1	(e.a) D.T.D. 197
	80604P6	Clip, cable for ass. 1	1	Sp. Steel
	80604P7	Clip, cable for ass. 2	4	Sp. Steel
	80604P8	Clip, cable for ass. 3	1	Sp. Steel
	DL.81	Hinge, concealed	8	Widney Dorlec
	80620P7	Hinge, assembly for lid	6	
	80620P8	Hinge, assembly for lid	1	
	80614P1	Lid, assembly	1	
	80618P1	Panel, L.H. group	1	
		Spares for:—		
5X/3181		Block, terminal 20-way	2	
5CY/2561		Breaker, circuit 15 amp	1	
5CY/2562		Breaker, circuit 25 amp	1	
5L/9953202		Lamp, filament	13	
5CX/-	D230/G (amber)	Lamp, signal	5	Bulgin
5CX/-	D230/G (red)	Lamp, signal	8	Bulgin
	80618P2	Panel, bare	1	LFS. 21
5CW/4199		Switch, double pole	2	

APPENDIX 3
SCHEDULE OF PARTS (Continued)

Ref No.	Part No.	Description	Qty.	Manufacturer, Spec. Material, Etc.
	80619P1	Panel, R.H. group	1	
		Spares for:—		
5X/2863		Block, terminal 10-way	1	
5CY/2599		Breaker, circuit 5 amp	1	
	80572P1	Bracket, relay	1	
	80571P1	Guard, potentiometer	1	
	80619P13	Label, for contactor switch	1	
	80619P4	Label, for heater mat switch	1	
5L/9953202		Lamp, filament	6	
5CX/-	D230/G/red	Lamp, signal	2	Bulgin
5CX/-	D230/G/amber	Lamp, signal	3	Bulgin
5CX/-	D230/G/green	Lamp, signal	1	Bulgin
		Ohmmeter 0-200 ohms	1	E.I.C. Ltd.
	80619P2	Panel, bare	1	LFS.21
		Potentiometer, 150 ohms	1	E.I.C. Ltd.
5CW/4182		Switch, double pole C/O	1	
5CW/-	S88/4	Switch, rotary	1	Sangamo Weston
5CW/-	S88/2	Switch, rotary	1	Sangamo Weston
	80577P1	Panel, supply	1	
5A/3104		Plug, output 28 volt	1	
10H/-	Z560050	Plug, 2-way 19 amp	1	
10H/-	Z560130	Plug, 4-way 19 amp	1	
10H/-	Z560200	Plug, 25 way 5 amp	1	
10H/-	Z560201	Plug, 25 way 5 amp	1	
	SM5/N33	Relay, miniature	10	
	80610P19	Sleeve, for handle	2	P.V.C.
	80615P15	Spigot, drum group	1	
		Spares for:—		
	80615P18	Ball, 0.25 in. dia.	2	
		Spring	1	D.T.D. 315
5A/2166		Socket, output 28 volt	1	
	80615P14	Spigot, for lid catch	1	S.I.
	80615P24	Spool, slinging assy.	4	T45 & S515
		Spring, for lid catch button	1	D.T.D. 215
	80610P18	Tube, handle 1 in. × 17G × 13.75	2	T.4
	80610P33	Washer, bearing for axle	2	S.I.
	80610P34	Washer, bearing for axle	2	S.I.
	No. 8471	Wheel, pneumatic tyred	2	

RESTRICTED

This file was downloaded
from the RTFM Library.

Link: www.scottbouch.com/rtfm

Please see site for usage terms,
and more aircraft documents.



LIGHTNING MK. 1
COVER PITOT HEAD
EB2-88-5111