

Chapter 3

TEST PANEL—STABILISED VOLTAGE POWER PACK

LIST OF CONTENTS

	<i>Para.</i>	Operation	<i>Para.</i>
<i>Introduction</i>	1	<i>General</i>	10
		<i>Test procedure</i>	11
		<i>After test</i>	12
Description		Servicing	
<i>General</i>	4	<i>General</i>	13
<i>Controls and Indicators</i>	6	<i>Fuses</i>	14
<i>Internal arrangement</i>	8	<i>Indicator lamp</i>	15
		<i>Pye socket</i>	16

LIST OF TABLES

	<i>Table</i>	<i>Table</i>
<i>Details of cable assemblies</i>	1	<i>Schedule of parts</i> 2

LIST OF ILLUSTRATIONS

	<i>Fig.</i>	<i>Fig.</i>
<i>General view</i>	1	<i>Circuit diagram (test panel and power pack)</i> 2

LEADING PARTICULARS

<i>Type</i>	<i>Avro Part No.</i> 1Z.9113
<i>Ref. No.</i>	26DC/95205

DIMENSIONS

<i>Length</i>	18.378 in.
<i>Width</i>	16 in.
<i>Height</i>	12 in.
<i>Weight</i>	15.5 lb.
<i>Operating voltage</i>	22-28 volts d.c.

Introduction

1. The test panel provides a convenient method of determining the on-load output voltage characteristics of the stabilized voltage power pack used on the Vulcan aircraft fuel system.
2. This chapter contains a description of the test panel and a simplified circuit diagram of the test panel and power pack circuit, together with operating and servicing instructions.
3. A description of the stabilized voltage power pack and its use is given in A.P.4505A, Vol. 1, Book 2 (Vulcan 1), and A.P.4505B, Vol. 1, Book 2 (Vulcan 2).

DESCRIPTION

General

4. The test panel (*fig. 1*) is a container of light alloy construction with a central recess which accommodates a rack for mounting the stabilized voltage power pack. The front of the container slopes upward towards the rear to form the control panel, and the back plate is detachable. The mounting rack is

secured to the container by eight 2 BA bolts and stiff-nuts and, with the exception that no anti-vibration mountings are fitted, is similar to the aircraft mounting rack (Avro Part No. V.6632).

5. Interconnection between the test panel and the power pack is made through a Pye socket fitted to the mounting rack. To facilitate entry of the power pack plug into the socket, the mounting rack is also provided with two dowels which engage the locating holes in the power pack body. Four pins on the Pye socket are used, two for the 28-volt d.c. input to the power pack, and two for the variable d.c. output from the power pack to the loading resistors housed inside the test panel. Access to the resistors and to the test panel wiring is made by removing the detachable back plate.

Controls and indicators

6. Mounted on the left-hand side of the control panel are the switches and meters associated with the input supply to the power pack under test. They consist of a master switch, a 0-10 ohm variable resistor for

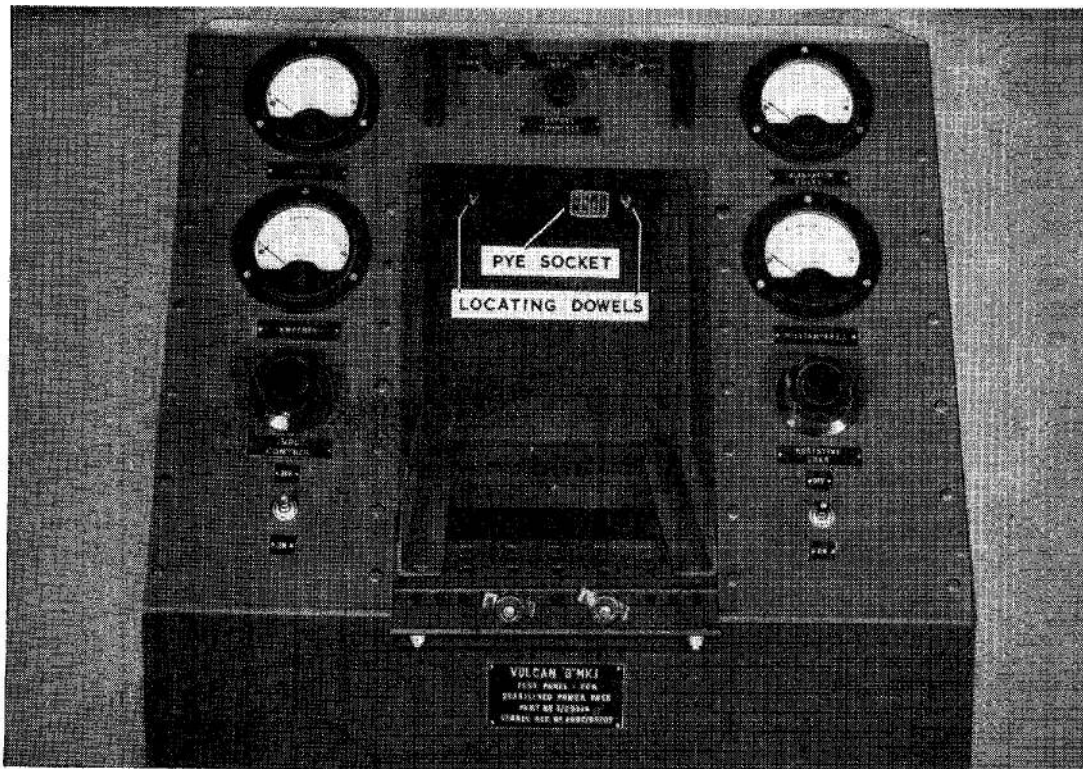

Fig. 1. General view

RESTRICTED

input control, a 0-5 amp. ammeter and a 0-30 volt voltmeter. A similar arrangement for control and indication of power pack output is provided on the right-hand side of the panel and consists of a loading switch, a 0-1000 ohm variable resistor for resistive load control, a 0-25 m.A. milliammeter and 0-50 voltmeter. The variable resistor is connected in series with a fixed resistance of 1750 ohms.

7. The supply terminals and fuses and an indicator lamp are mounted at the top centre position on the control panel. The lamp will light when the supply to the power pack is switched on, provided the power pack is functioning normally. The slight interval between switching on and the lamp striking is normal and is the warming up time necessary for the filaments of the valves in the power pack.

Internal arrangement

8. The fixed 1750 ohm resistor for loading the power pack is mounted on a bracket riveted to the left-hand side plate of the test panel, the resistor being secured to the bracket by 4 BA bolts and stiff nuts.

9. For the internal wiring, a cable loom made up from lengths of unipren 6 cable is used for connecting the test panel to the power pack; individual lengths of cable being used for other connections. Details of these cables are given in TABLE 1.

OPERATION

General

10. The stabilized voltage power pack is designed to give satisfactory performance within the input voltage range of 22 to 28 volts d.c. The normal test is carried out with an input voltage of 22 volts d.c. in order that performance under the most unfavourable conditions shall be observed. It is found that performance improves as the input voltage is raised towards the upper limit.

Test procedure

11. To conduct a test on a stabilized voltage power pack proceed as follows:—

- (1) Set all switches on the test panel to OFF.
- (2) Position the power pack on the mounting rack to engage the locating dowels, and carefully couple the power pack plug to the Pye socket.

(3) Connect a direct current supply of suitable voltage to the input terminals of the test panel.

(4) Set the master (input) switch to ON and adjust the input control to give an indicated 22 volts on the 0-30 voltmeter.

Note . . .

Within a few seconds of switching ON, the heater elements of the valves in the power pack will reach normal working temperature and the indicator lamp should light.

(5) With the right hand (load) switch set to OFF, adjust the power pack percentage refuelling selector to 100 per cent. An output of 50 volts should be shown on the 0-50 voltmeter with the selector at this setting.

(6) Set the right hand (load) switch to ON and adjust the load current, by means of the resistive load control, to obtain an indication of 20 mA. on the milliammeter. At this load the indicated output voltage should be within 1 per cent of 50 volts (i.e. voltage drop not to exceed 0.5 volts).

(7) The linearity of the percentage selector can be checked by selecting 80, 60, 40 per cent, etc., at which settings the indicated output voltage should be 40 volts, 30 volts, 20 volts, etc., respectively.

Note . . .

The procedure for adjusting the stabilized voltage power pack is contained in A.P.4505A, Vol. 1, Book 2, Section 5, Chapter 1, Group 5.

After test

12.

- (1) Set all test panel switches to OFF.
- (2) Disconnect the external power supply.
- (3) Remove the power pack from the test panel.

SERVICING

General

13. There is little servicing required on the test set which contains no moving parts other than the movements of the four instruments. The instruments should be serviced as necessary in accordance with instructions currently in force, and periodically calibrated against sub-standard instruments.

RESTRICTED

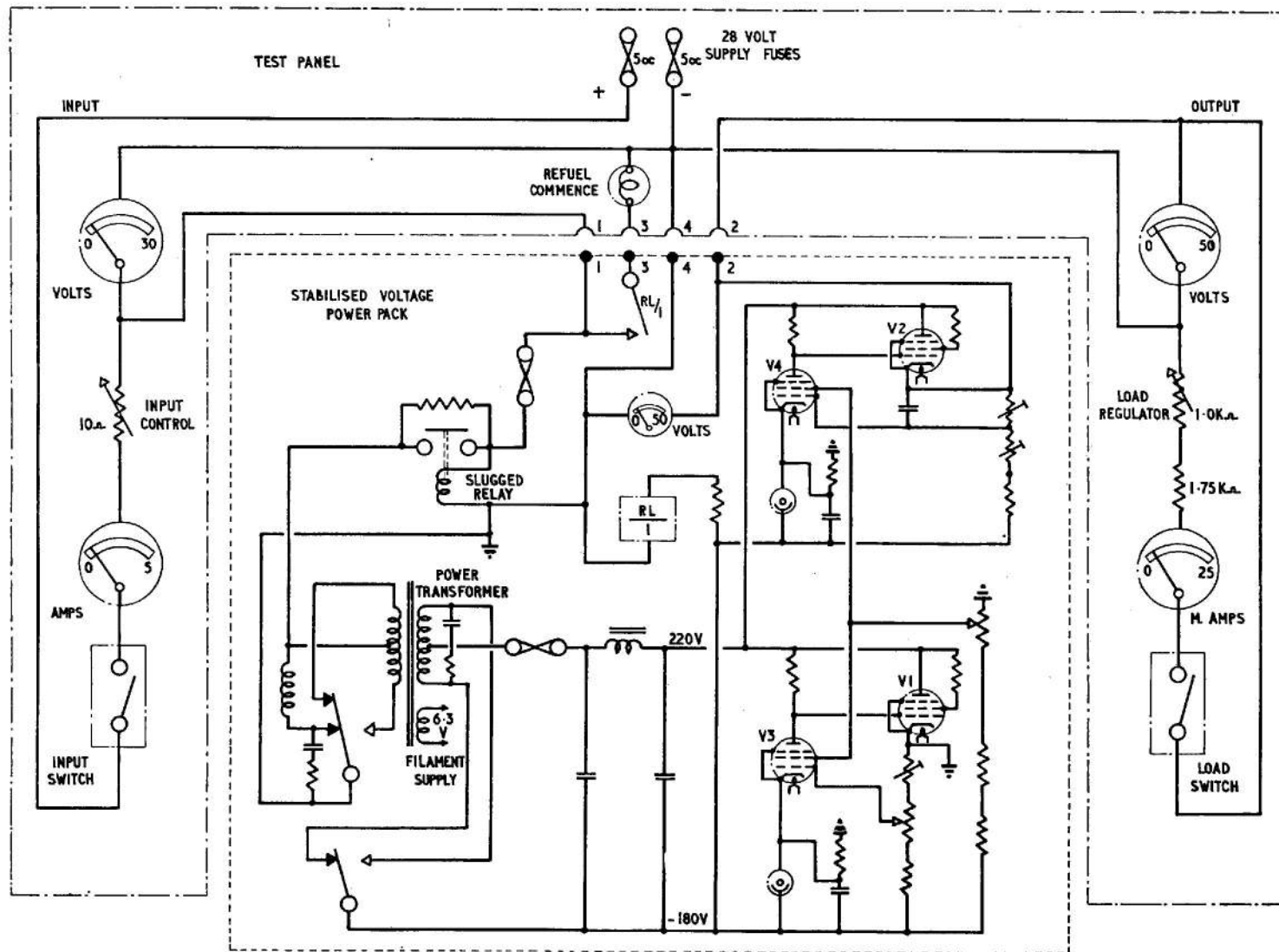

Fig. 2. Circuit diagram (test panel and power pack)

Fuses

14. These should be checked periodically for continuity.

Indicator lamp

15. If, after switching on the power supply, the lamp fails to light after the usual slight

delay, check the filament for serviceability before condemning the power pack.

Pye socket

16. This should be kept clean, and any damage made good without delay. A faulty socket could damage an otherwise serviceable power pack.

Table 1
Details of Cable Assemblies

PART NO.	FROM (END A)	TO (END B)
2Z/9649	0-30 voltmeter +ve	Pye socket, pin 1
	Milliammeter +ve	Pye socket, pin 2
	Lamp (refuel commence) —1	Pye socket, pin 3
	0-30 voltmeter —ve	Pye socket, pin 4
3Z/9649	Fuse No. 1-2	Switch No. 1-2
4Z/9649	Switch No. 1-1... ..	Ammeter +ve
5Z/9649	Ammeter —ve	10 ohm resistor —1
6Z/9649	Input terminal +ve	Fuse No. 1-1
7Z/9649	Milliammeter —ve	Switch No. 2-1
8Z/9649	Milliammeter +ve	0-50 voltmeter +ve
9Z/9649	Switch No. 2-2... ..	1000 ohm load regulator —1
10Z/9649	1750 ohm fixed resistance—2	0-50 voltmeter —ve
11Z/9649	0-50 voltmeter —ve	0-30 voltmeter —ve
12Z/9649	0-50 voltmeter —ve	Lamp (refuel commence) —2
13Z/9649	0-30 voltmeter —ve	No. 2 fuse —2
14Z/9649	Input terminal —ve	No. 2 fuse —1
15Z/9649	10 ohm resistor —2	0-30 voltmeter +ve
16Z/9649	1750 ohm fixed resistance —1	1000 ohm load regulator —2

Table 2
Schedule of Parts

Part No.	Description	Qty.	Spec.	Material size per part, manufacturers, etc.
1Z9113	Test panel, stabilized power pack	1	Complete	
2Z9113	Container	1	Complete	
3Z9113	Front panel	1	L.72	Alum Alloy 18.378 in. × 22.5 in. × 16 SWG.
4Z9113	Side panel	2	L.72	Alum Alloy 16 in. × 12 in. × 16 SWG.
5Z9113	Bottom panel	1	L.72	Alum Alloy 18.25 in. × 12 in. × 16 SWG.
38Z9113	Back plate	1	L.72	Alum Alloy 18.378 in. × 16.128 in. × 16 SWG.
44Z9113	Tray	1	Complete	
1Z9750	Mounting rack	1	Complete	
13Z9113	Voltmeter 0-30 V.d.c.	1		Sangamo Weston Type S.20
14Z9113	Ammeter 0-50 A.d.c.	1		Sangamo Weston Type S.20
15Z9113	Voltmeter 0-50 V.d.c.	1		Sangamo Weston Type S.20
16Z9113	Milliammeter 0-25 mA.d.c.	1		Sangamo Weston Type S.20
17Z9113	Skirted knob, 2 in.	2		P.X. Fox Ltd., Horsforth, Yorks.
18Z9113	Potentiometer, 10 ohm	1	No. PX25/B	P.X. Fox Ltd., Horsforth, Yorks.
19Z9113	Potentiometer, 1000 ohm	1	No. 1 VC.13	Bulgin Ltd., Essex
20Z9113	Switch	2	No. S.261	Bulgin Ltd., Essex
21Z9113	Terminal black	1	No.L1001/1W	Belling-Lee
22Z9113	Terminal red	1	No.L1001/1W	Belling-Lee
23Z9113	Warning lamp	1	5C/1069	Rotax Type H.2702
24Z9113	Filament, 24V, 3 watt	1	5L/9951272	
25Z9113	Fuse, 5 amp. (Slydlock)	2	X.5344	E. Wilcox Ltd., Wythenshawe, Manchester
39Z9113	'Pye' socket body and angle entry cover	1	734491/730606	Power Controls Ltd., Newmarket
40Z9113	Resistor, 1750 ohm	1	P.R.138	Bulgin Ltd., Essex

RESTRICTED

This file was downloaded
from the RTFM Library.

Link: www.scottbouch.com/rtfm

Please see site for usage terms,
and more aircraft documents.

