

Chapter 2

PORTABLE BOMB CIRCUIT (SHACKLETON MK. 3) TEST SET

LIST OF CONTENTS

	<i>Para.</i>		<i>Para.</i>
<i>Introduction</i>	1	<i>Sono-buoy</i>	18
Description		<i>Heaters</i>	19
<i>General</i>	3	<i>Marine marker</i>	20
<i>Test box</i>	4	<i>Fuzing circuits</i>	21
<i>Connector set</i>	9	<i>Jettison and reset</i>	22
<i>Recorder</i>	10	<i>Lindholme</i>	23
Operation		<i>Muff doors</i>	24
<i>General</i>	12	<i>Use of recorder</i>	25
<i>Release test</i>	15	<i>Recorder operation</i>	26
<i>Fault reset</i>	17	<i>50 c/s timing</i>	29
		<i>Interpretation of the record</i>	30

LIST OF ILLUSTRATIONS

	<i>Fig.</i>		<i>Fig.</i>
<i>Portable bomb circuit test set</i>	1	<i>Interconnection diagram</i>	5
<i>Indicator and control panel</i>	2	<i>Recorder circuit</i>	6
<i>Connectors</i>	3	<i>Circuit diagram</i>	7
<i>Recorder</i>	4		

LEADING PARTICULARS

Portable bomb circuit (Shackleton Mk. 3) test set ..	Ref. No. 26FP/95550
<i>Event recorder, Type 10</i>	<i>Ref. No. 5G/3211</i>
<i>Input voltage</i>	28 d.c.
<i>Overall dimensions</i>	36.5 in. × 19.5 in. × 27.75 in.

RESTRICTED

Introduction

1. The test set provides facilities for testing the armament installation of a Shackleton Mk. 3 aircraft. The unit is connected to the butt connectors in the aircraft bomb bay, and simulates in a simple form the circuits of the Avro heavy and medium stores carriers.
2. The equipment, which is designed for ease of transportation, comprises a test box and connector storage boxes supported in a frame (fig. 1). The test box contains a uniselector, relays and banks of indicator lamps, which load the various aircraft circuits and give indication of satisfactory functioning. Connectors are provided for connecting the test box to the aircraft carrier stations and when not in use are stored in boxes below the test box (fig. 1). Facilities for connecting a recorder to the test box are provided to enable the quality of the release pulses to be checked.

DESCRIPTION

General

3. The test box is supported in a channel section frame and the connector boxes are stowed in a rack below the test box. The frame is fitted with removable carrying handles and rests on skids formed from aluminium bar. The connector boxes are held in the rack by retaining plates, which are secured to the front cross member by knurled-headed bolts. To gain access to the connectors, the bolts are slackened off, the retaining plates turned through 90 deg., and the bolts tightened down. The connector box may then be withdrawn halfway, and the hinged lid opened.

Test box

4. The test box comprises an alloy case with a detachable lid, and four snap fasteners for securing the lid to the box. The top panel of the box carries the controls and indicators, and the internal components comprising a uniselector and three relays are mounted on a hinged Paxolin tray. At the front left-hand corner of the box is the recorder housing; the

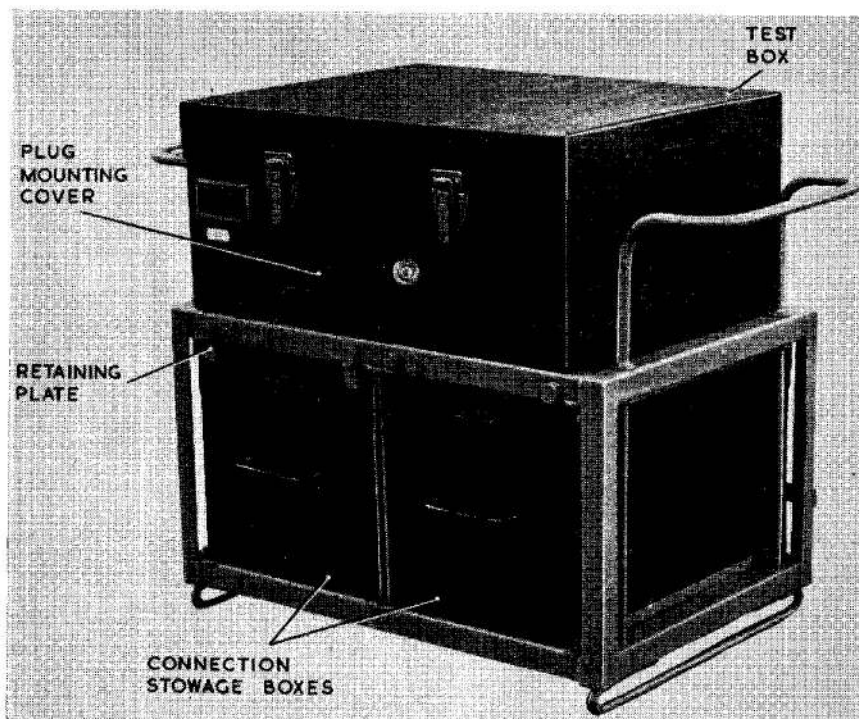

Fig. 1. Portable bomb circuit test set

RESTRICTED

corner is hinged and can be folded down to give access to the recorder interior and mounting. The recorder is secured to its mounting bracket by two knurled-headed bolts.

5. The indicators mounted on the test box panel are arranged in four rows and seven columns. Each row corresponds to a group of carrier stations, referred to on the test box as 'positions'. The station groups or positions comprise the following carrier stations:—

Position 1—Stations 1, 2 and 3.

Position 2—Stations 4, 5 and 6.

Position 3—Stations 7 and 8.

Position 4—Stations 9, 10 and 11.

Each position is fed from two junction boxes in the bomb bay, one supplying the starboard butt connectors and the other supplying the port connectors. Reference should be made to the Aircraft Handbook for details of the armament installation.

6. From left to right the columns of indicators are as follows:—

(1) **RELEASE LAMPS**—Each position has three green release lamps, each lamp representing a release unit and is operated via the uniselector by the release pulses from the aircraft bomb distributor.

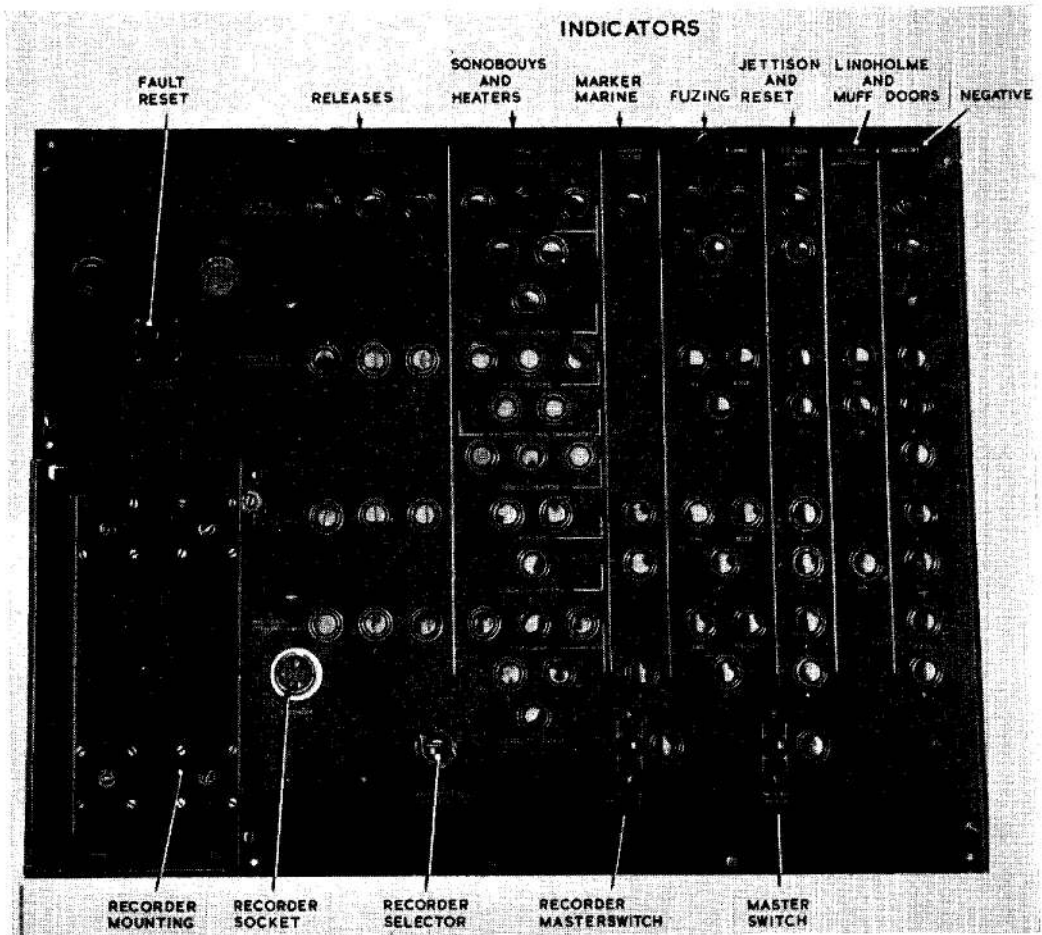

Fig. 2. Indicator and control panel

RESTRICTED

(2) **SONO-BUOYS**—these are green release indicators and are operated by the 12-way Sono-buoy selected switch in the aircraft. The twelve indicators are arranged, five at position 1, two at position 3, and five at position 4.

(3) **HEATERS**—Also in the second column are arranged the blue Sono-buoy heaters, torpedo heaters and muff heaters indicators.

(4) **MARINE MARKER**—provided at positions 1, 3 and 4 and are operated via the marine marker switch and bomb firing switch in the aircraft.

(5) **FUZING**—three red fuzing indicators are arranged at each position, these being labelled **TAIL**, **NOSE** and **VT**. The positive supply is switched to the indicators by the nose and tail and VT switches in the aircraft.

(6) **JETTISON** and **RESET**—these are provided at all four positions, the jettison indicator being coloured red and the reset indicator yellow.

(7) **LINDHOLME** and **MUFF DOOR**—Lindholme indicators are provided at positions 2 and 3, but the Lindholme supply lines are available only at carrier stations No. 6 and 7. A single muff door indicator is provided at position 2.

(8) **NEGATIVE**—the negative indicators are provided two at position 1, 3 and 4 and three at position 2. The indicators check the continuity of the release and heating negative lines.

7. Below the indicator bank are mounted the control switches and recorder socket and to the left of the indicator bank the fault reset push switch. The function of these components is as follows:—

(1) **MASTER SWITCH**—is a single-pole toggle switch connected in the positive line of the 28V supply to the test box, mounted adjacent to the switch is the amber power-on indicator.

(2) **RECORDER MASTER SWITCH**—is a single-pole toggle switch, which when set to the ON position completes the 28V supply to the recorder via poles G and L of the recorder connector (fig. 7)

and also switches the supply to the red recorder-on indicator. The presence of the 28V positive supply at poles G and L of the recorder prepares the unit for operation by heating the valves and energizing the transformer-vibrator power unit (fig. 6).

(3) **STATION RECORDER SELECTOR**—is a 5-way switch which enables the recorder to be operated by the nose fuzing positive from any of the four carrier station positions. The selected positive energizes relay 3 (fig. 7), and a

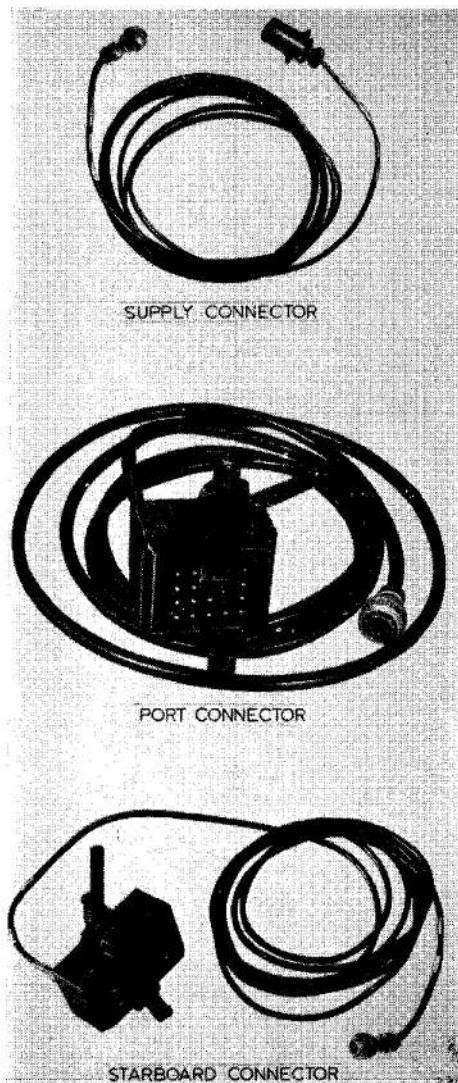

Fig. 3. Connectors

28V supply is switched to pole F of the recorder. The recorder track is thereby set in motion and the 50 c/s pen energized.

(4) **RECORDER SOCKET**—is a 12-pole socket mounted adjacent to the recorder housing. A short 12-way connector is provided for linking the test box to the recorder.

(5) **FAULT RESET SWITCH**—is a push switch which enables a faulty release line to be by-passed, thus moving the unselector on to the next release line.

8. The test box input plugs are mounted on a recessed panel on the front of box and covered by a hinged panel. The plugs are numbered 1 to 9 and are connected to the aircraft as shown in fig. 5.

Connector set

9. The connector set comprises nine connectors, eight for connecting the test box plugs to the aircraft bomb bay connectors, and one connector for connecting the test box to the 28V d.c. supply. The circuit diagram of the connectors is given in fig. 7.

Recorder

10. The recorder used with the test set is the Event Type 10 (fig. 4). The travelling paper (teledeltos paper), which is carried by two reels, the feed reel and the take up reel, is a black graphite-unpregnated paper, faced with white tissue. The reels are driven by a permanent magnet motor and the paper, tissue uppermost, passes over a contact plate which is at chassis potential. The recording pens when energized, leave a trace on the paper by burning away the tissue immediately below the pen.

11. The recorder is fitted with six pens but only two are used in the Type 10 unit. One is energized at 50 c/s and marks a dot on the paper every 20 milliseconds, the second pen traces a line during the ON period of the release pulse.

OPERATION

General

12. The test set is connected to the aircraft in the manner shown in fig. 5, with the equipment positioned about mid-way along the bomb bay. The 28V supply connector is

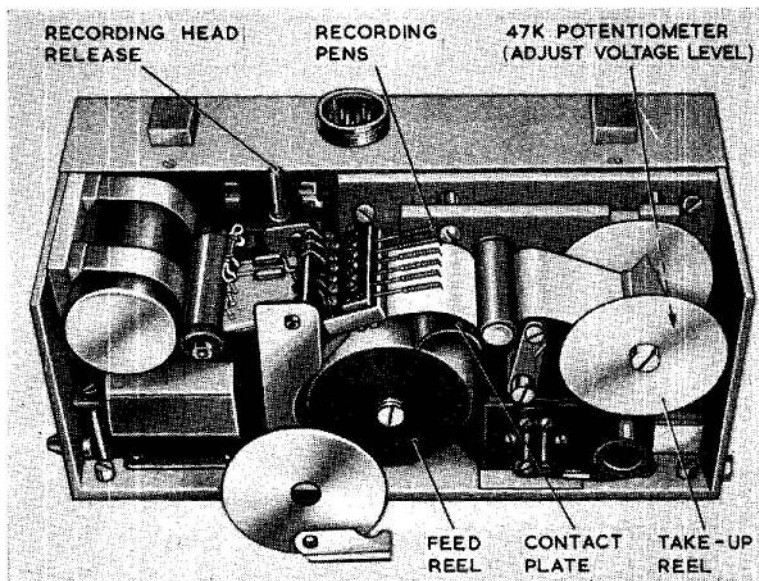

Fig. 4. Recorder

RESTRICTED

terminated in a 7-pole clipper plug for connecting to the aircraft supply. Intercomm. between the operators in the aircraft and the test set should be by means of the normal aircraft intercomm., using the external intercomm. socket.

13. With the ground supplies switched on and the test set MASTER SWITCH closed the SUPPLY ON indicator adjacent to the master switch should light. Ensure that the RECORDER MASTER SWITCH and the STATION RECORDER SELECTOR SWITCH are set to OFF.

14. In addition to the SUPPLY ON indicator, when the MASTER SWITCH is closed the three MUFF HEATERS, M.H. THERMOSTAT (muff heater thermostat), M.D. (muff doors), RESET and the NEGATIVE indicators should light. To test the circuits associated with the remaining indicators the appropriate switches in the aircraft should be operated, for the detailed testing procedure reference should be made to the appropriate Aircraft Servicing Schedule.

Release test

15. The twelve RELEASE indicators are operated by the separate 28V supply to the test box via bank B2 of the uniselector (fig. 7). The first RELEASE indicator in position 2 should light when the MASTER SWITCH is closed, the positive supply to the indicator is completed by the wiper of uniselector bank B2 and contact No. 1. The release pulses are derived from the 16-way distributor in the aircraft, and are used in the test box to operate the uniselector.

16. To test the first release line, the circuit in the aircraft is selected, and the distributor operated. When the pulse arrives at the test box the uniselector is energized, and as the pulse ceases the uniselector steps on to the next line. The first RELEASE indicator on the test box now goes out, and the second indicator should light. The action of the RELEASE indicator going out signifies that the line is satisfactory. At bank B2 (fig. 7) the wiper has

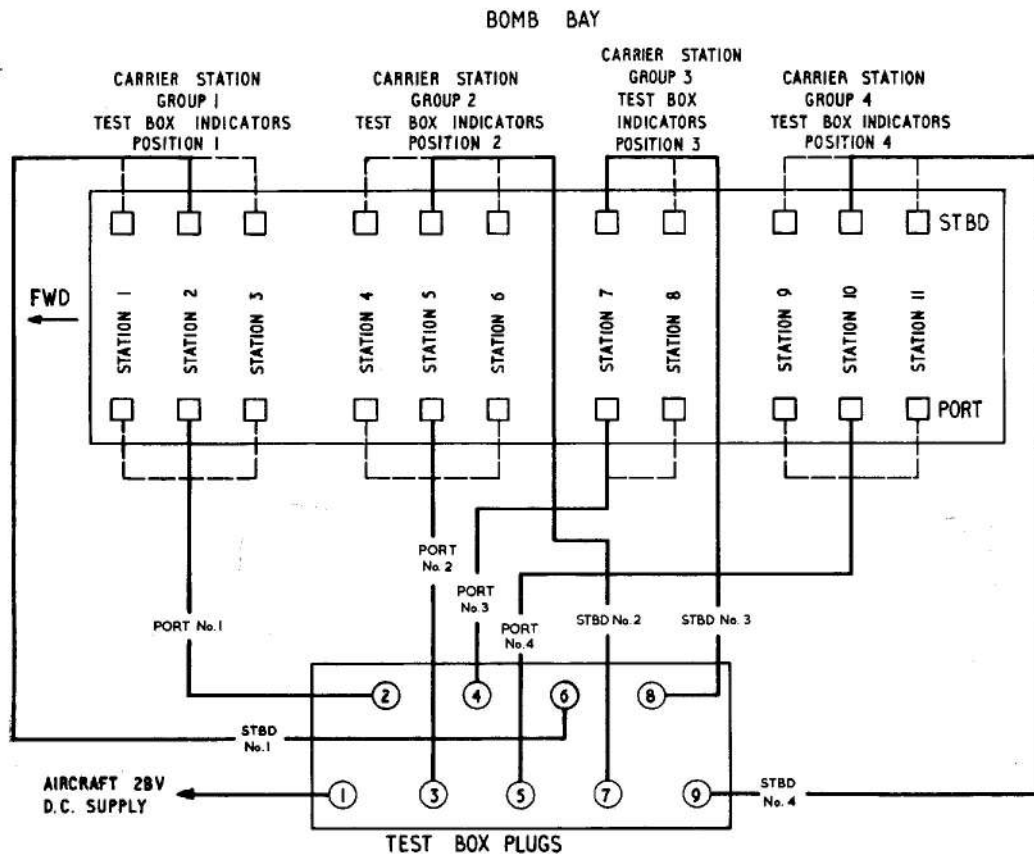

Fig. 5. Interconnection diagram

RESTRICTED

moved on to contact No. 2 and is now ready to receive the next release pulse. The remaining release lines may be similarly tested.

Fault reset

17. Should the uniselector fail to operate the appropriate RELEASE indicator will remain on, indicating a faulty release line or pulse. The remaining circuits may be tested by pressing the fault reset switch which causes the uniselector to step past the faulty line. When the 12th release line is tested the uniselector will step on to contact No. 13. On the uniselector bank B2, contacts No. 13 to 30 are bridged and a positive is switched to the uniselector coil via the interrupter contacts. Hence the uniselector will step round and reset to contact No. 1.

Sono-buoy

18. The SONO-BUOY indicators are operated by the sono-buoy release positives from the aircraft. The sono-buoy release lines are selected at the 12-way switch in the aircraft and the line energized by pressing the bomb firing switch. Thus the indicators will light while the bomb firing switch is held closed.

Heaters

19. The three MUFF HEATERS and the M.H. THERMOSTAT (muff heater thermostat) indicators should light immediately the aircraft supply is switched on. The M.H. supply and torpedo heater supplies are checked by closing the stores heating switch in the aircraft, and observing that the indicators operate.

Marine markers

20. To test the marine marker circuits at positions 1, 3 and 4, the marine marker switch in the aircraft should be closed and the firing switch pressed. The marine marker circuits are supplied by a 4-way auto-selector and pressing the firing switch initiates a pulse in each of the four circuit lines in turn. Hence the firing switch should be pressed four times, once for each circuit.

Fuzing circuits

21. The fuzing circuits (NOSE, TAIL and VT) are tested by operating the appropriate switch in the aircraft and observing that the corresponding indicator operates.

Jettison and reset

22. The RESET indicators are supplied by positive supplies from normally closed contacts in the jettison relays and should indicate when the aircraft supply is switched on. The jettison relay is energized, via the bomb door micro switches, when the bomb jettison switch is closed. When the jettison relays operate the JETTISON indicator on the test box should light and the RESET indicators should go out.

Lindholme

23. Lindholme circuits are provided at positions 2 and 3, but are available only at carrier stations No. 6 and 7. In order to test the two Lindholme circuits, the circuits should be connected to the distributor by setting the pre-selector in the aircraft to the appropriate positions (refer to Aircraft Handbook). The circuits should then be selected at the selector switch box and the distributor operated, the two indicators should light in turn as the firing switch is pressed.

Muff doors

24. The MUFF DOORS indicator at position 2 on the test box should operate when the muff doors switch in the aircraft is closed. This completes a positive supply to the test box indicator, and at the same time energizes relay RL1 (fig. 7). A positive from the aircraft, present at plug 7 pole J of the test box, is thus switched by the contacts of relay RL1, back to the aircraft, to operate the aircraft muff doors indicator.

Use of recorder

25. When it is required to check the length and spacing of the release pulses, the recorder is loaded with paper, attached to its mounting on the test box and connected to the recorder socket by the short connector supplied with the equipment. When the MASTER SWITCH is set to ON a 28V positive supply is completed to poles G and L of the recorder plug (fig. 7) and prepares the recorder for operation by heating the valves and energizing the vibrator transformer power unit. The recorder motor is set in motion and the 50 c/s pen energized when the STATION RECORDER SELECTOR SWITCH is set to position 1, 2, 3 or 4, and nose fuzing selected in the aircraft. Nose fuzing, therefore, must be selected immediately prior to the operation of the release circuits. The 50 c/s pen marks the paper with dots at 20 milli-

RESTRICTED

Fig. 6. Recorder circuit

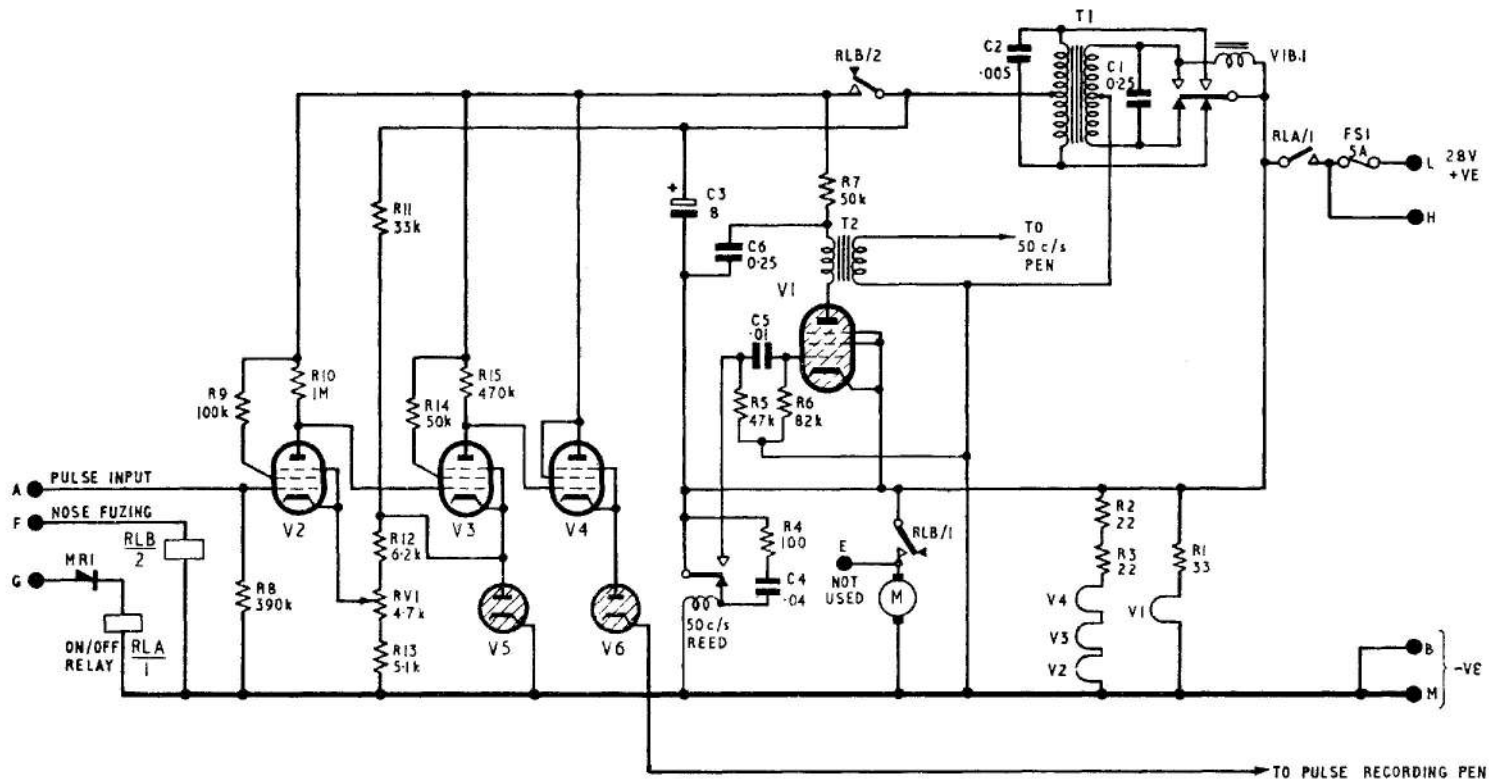

V2 V3 & V4 (CV476)	V5 (CV284) V6 (CV287)	V1 (CV797)

second intervals and provides the timebase against which the pulse duration and spacing can be checked.

Recorder operation

26. When the RECORDER MASTER switch is set to ON a 28V positive supply is switched to poles G and L of the recorder, relay RLA (fig. 6) operates and contacts RLA/1 close to complete the supply to the valve heaters and power unit. When nose fuzing is selected in the aircraft, relay 3 in the test box is energized and a positive supply appears at pole F of the recorder energizing relay RLB. Contacts RLB/2 complete the H.T. supply to the valves, and contacts RLB/1 switch on the recorder motor, setting the recording track in motion.

27. With no pulse input to the recorder valve V2 is biased to cut-off (fig. 6), V3 is conducting and V4 is cut-off. The gas-filled diode V6 is de-ionized and V5 functions as a voltage reference. The release pulses which are approximately square in waveform are applied to the grid of V2 (fig. 6). The pulse, if above a predetermined voltage level, will cause V2 to conduct; this level is set by RV1. With V2 conducting V3 is switched off and the potential on the grid of V4 rises to H.T.

The potential on the cathode of V4 rises, causing V6 to conduct, and a current to flow in the circuit formed by the contact plate, paper, pen, V6 and V4.

28. The trailing edge of the pulse switches off valve V2, and the current flowing through the pens circuit ceases. The circuit remains in this condition until the next release pulse arrives at the grid of V2. The pen thus records the duration and spacing of the release pulses.

50 c/s timing

29. A tuned reed (fig. 6) supplies 28V to the grid of V1 at a frequency of 50 c/s, and the output, via transformer T2, is taken to the 50 c/s pen. The pen will be energized by a high voltage 50 times per second, causing a dot to appear on the travelling paper every 20 milliseconds.

Interpretation of the record

30. The record shows the release pulses as black lines, the length indicating the duration of the pulse. Alongside the pulse record are a series of dots at 20 millisecond intervals. The length of the pulse and period of the pulse may be checked by dividers using the 20 millisecond dots as a reference scale.

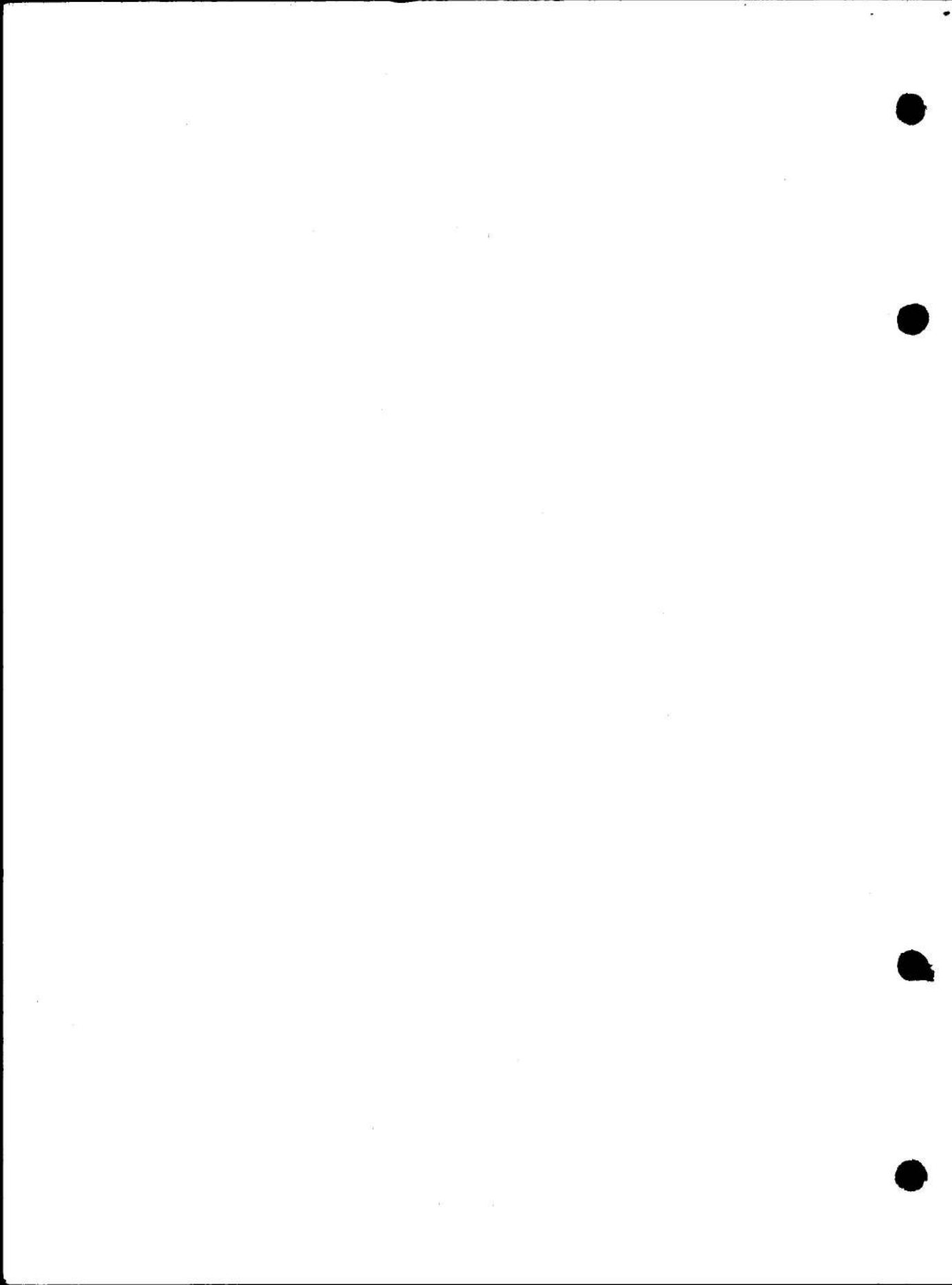

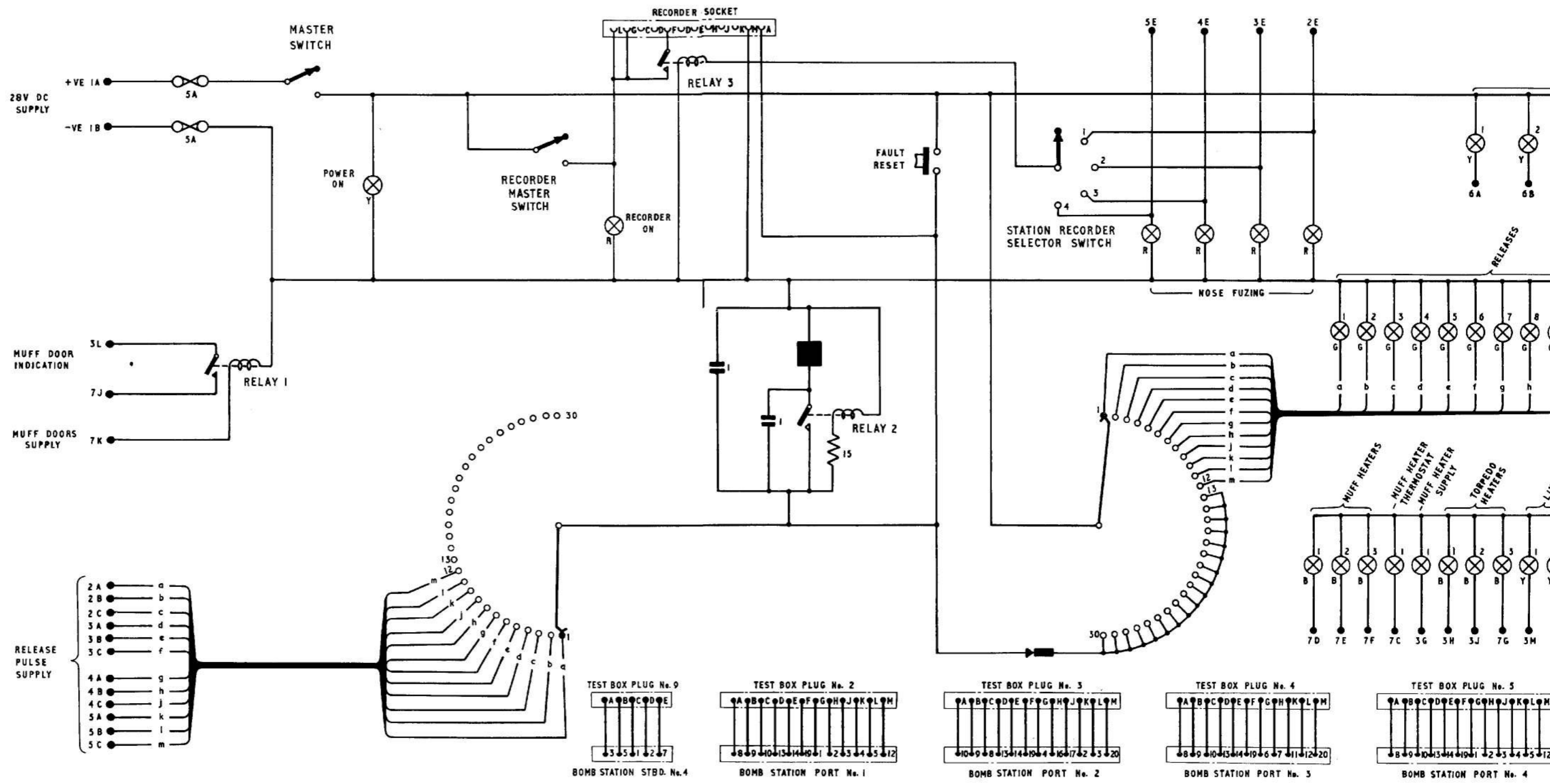
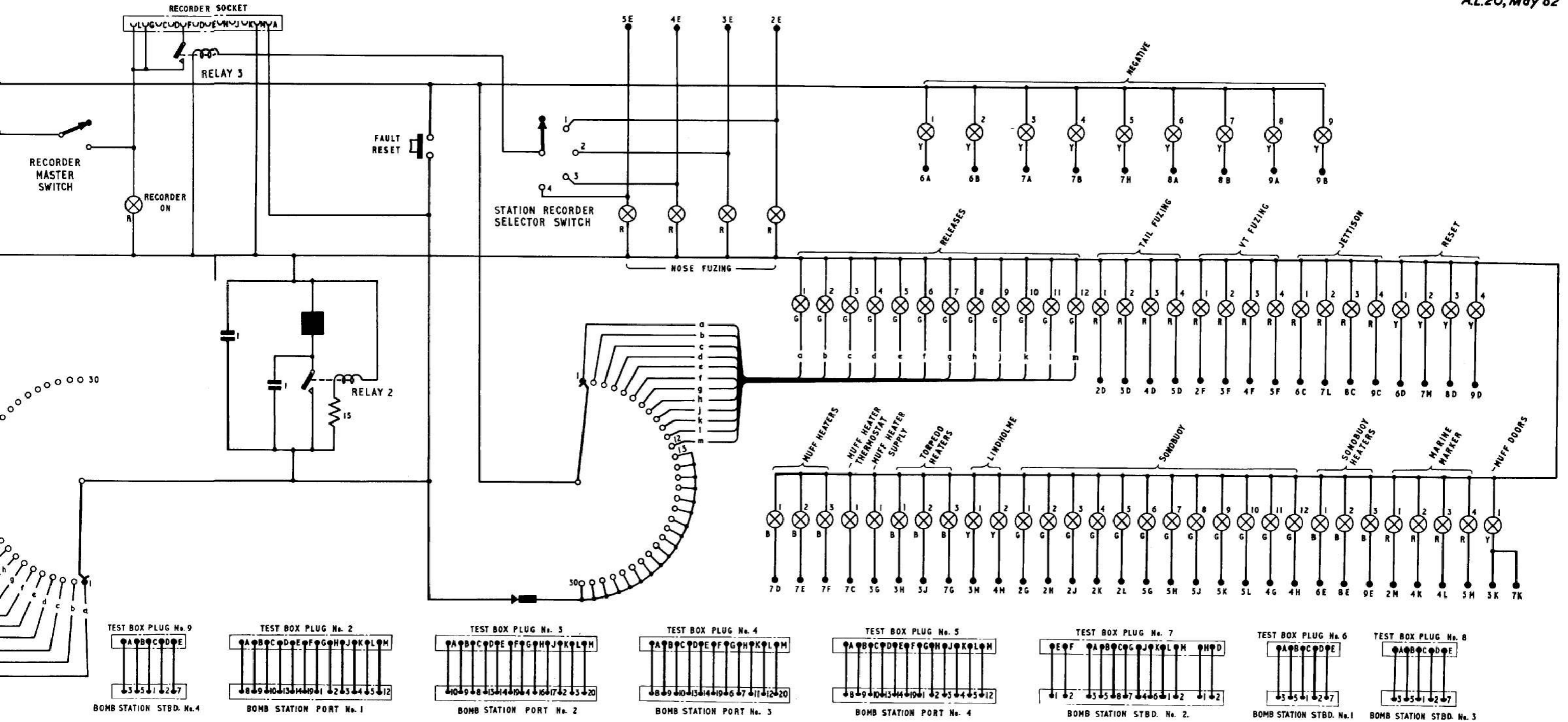

Fig. 7

Circuit diagram
R E S T R I C T E D



Circuit diagram
 R E S T R I C T E D

Fig. 7

This file was downloaded
from the RTFM Library.

Link: www.scottbouch.com/rtfm

Please see site for usage terms,
and more aircraft documents.

