

Chapter 1

FIRESTREAK AIRFRAME SIMULATOR TEST SET

LIST OF CONTENTS

	Para.		Para.
<i>Introduction</i>	1	<i>Rear panel assembly</i>	7
Description	2	<i>Connectors</i>	8
<i>Operation</i>	3	<i>Wiring</i>	9
<i>Materials</i>	4	<i>Final assembly</i>	10
Manufacture		<i>Electrical check</i>	11
<i>Test set case</i>	5	Servicing	12
<i>Front panel assembly</i>	6		

LIST OF TABLES

	Table		Table
<i>Test set case components</i>	1	<i>Connector components</i>	4
<i>Front panel assembly components</i>	2		
<i>Rear panel assembly components</i>	3	<i>Miscellaneous wiring accessories</i>	5

LIST OF ILLUSTRATIONS

	Fig.		Fig.
<i>Test set case—general dimensions</i>	1	<i>Rear panel—layout</i>	4
<i>Front panel—layout</i>	2		
<i>Front panel—construction details</i>	3	<i>Circuit diagram</i>	5

Introduction

1. The Firestreak airframe simulator test set is required when bay servicing the Firestreak guided weapon pack of Lightning aircraft to provide those circuits and indications normally obtainable on the aircraft.

DESCRIPTION

2. The test set consists of a wooden case to which are fitted light alloy front and rear panels. The front panel is fitted with switches, lamps and fuses, while the rear panel carries the outlets for three cables which connect with a weapon pack.

RESTRICTED

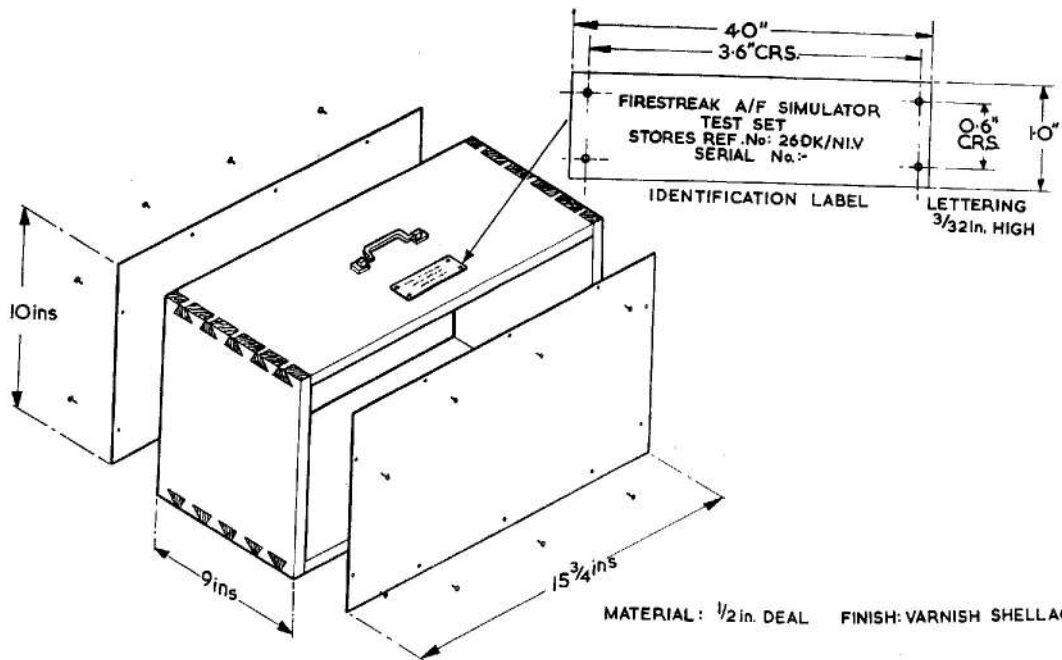

Fig. 1. Test set case—general dimensions

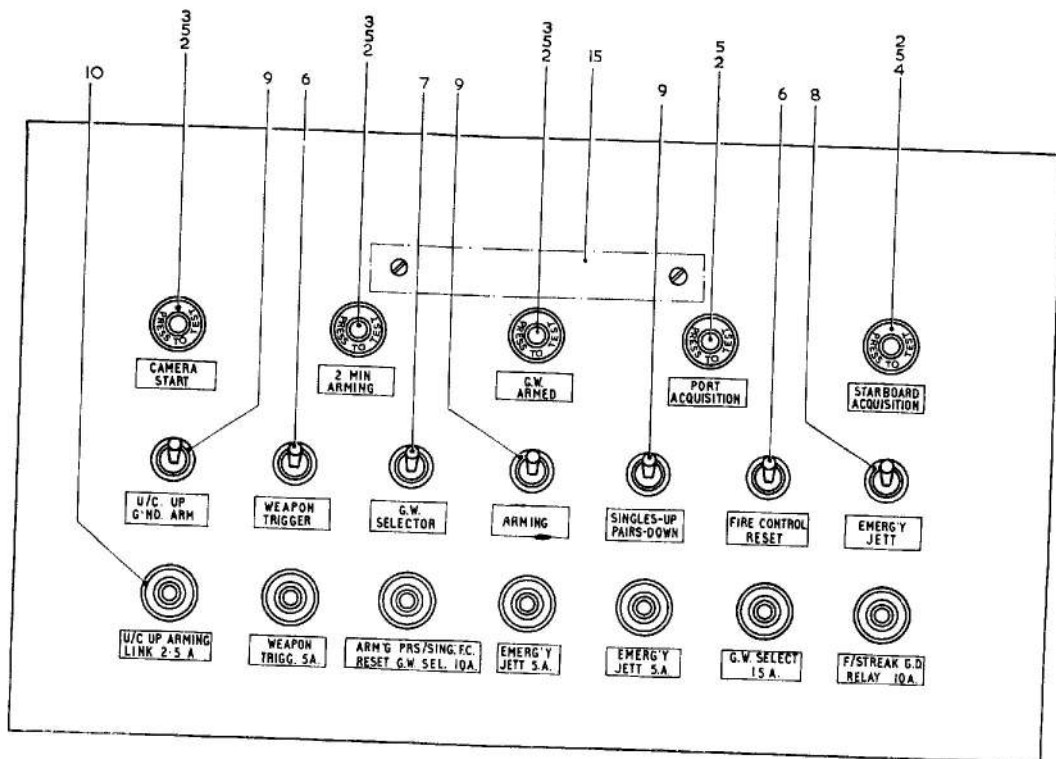

Fig. 2 Front panel—layout

RESTRICTED

Operation

3. The use of the test set during weapon pack bay servicing is covered by C.S.D.E. Firestreak Provisional Part 6, Book 2, Chap. 12 which will soon be superseded by A.P. 4724, Vol. 5, Part 6, Book 3, Sect. 5, Chap. 4.

Materials

4. Five lists of materials and components necessary to make a test set are shown in Tables 1 to 5 inclusive.

MANUFACTURE**Test set case**

5. In making the case, refer to Fig. 1 for details of dimensions and assembly, and Table 1 for components and materials. The following is the recommended procedure:—

- (1) Mark out and cut $\frac{1}{2}$ in. deal sections.
- (2) Mark out and cut dovetail joints.
- (3) Apply glue to joints and assemble top, bottom and sides.

(4) Finish exterior surfaces of case with shellac varnish.

(5) Fit handle and identification label to top of case.

Front panel assembly

6. Refer to Fig. 3 for the constructional details of the front panel, Fig. 2 for assembly details and Table 2 for components. Proceed as follows:—

- (1) Mark out light alloy sheet and cut. (*fig. 3*).
- (2) Mark out and drill holes (*fig. 3*).

Note . . .

Some switches are supplied with locking rings which do not require a 0.0625 in. hole above the 0.469 in. hole in which the switch is mounted.

(3) Modify four indicating lamps using Items 3 and 4, Table 2.

(4) Fit indicating lamps, switches and fuses (*fig. 2*).

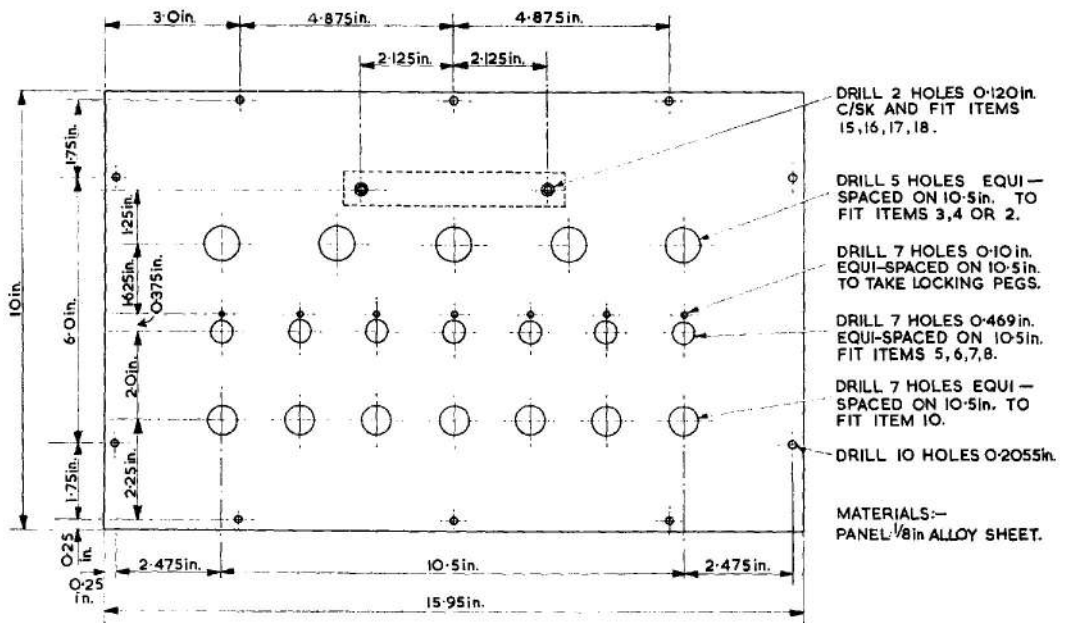

Fig. 3. Front panel—construction details

RESTRICTED

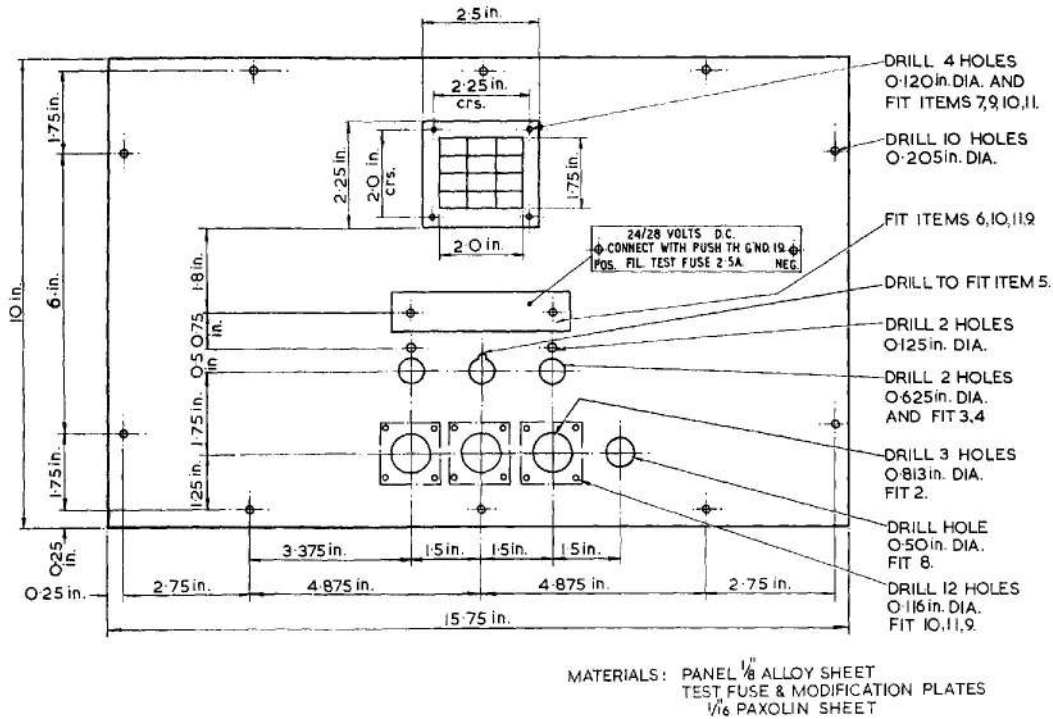

Fig. 4. Rear panel—layout

- (5) Fit terminal block (Item 15) with 6 BA screws, nuts and lock washers (fig. 3).
- (6) Fit component identification strips with lettering as shown in Fig. 2.

- (4) Fit terminals, fuse holder and grommet.
- (5) Fit modification and filament test labels.

Rear panel assembly

7. Refer to Fig. 4 for the construction details of the rear panel assembly and Table 3 for components. Proceed as follows:—

- (1) Mark out light alloy sheet and cut.
- (2) Mark out and drill holes.
- (3) Fit cable outlet plates with screws, nuts and washers.

Connectors

8. Refer to Fig. 5 for a circuit diagram of the test set, showing the leads which comprise the connectors, and Table 4 for components. Make up connectors as follows:—

- (1) Cut 15 pieces of Vin 20 cable and 5 pieces of Vin 12 cable, each 12 ft. 8 in. long and prepare one end of each cable.
- (2) Fit insulating sleeves to cables.
- (3) Bunch cables as shown in Fig. 5

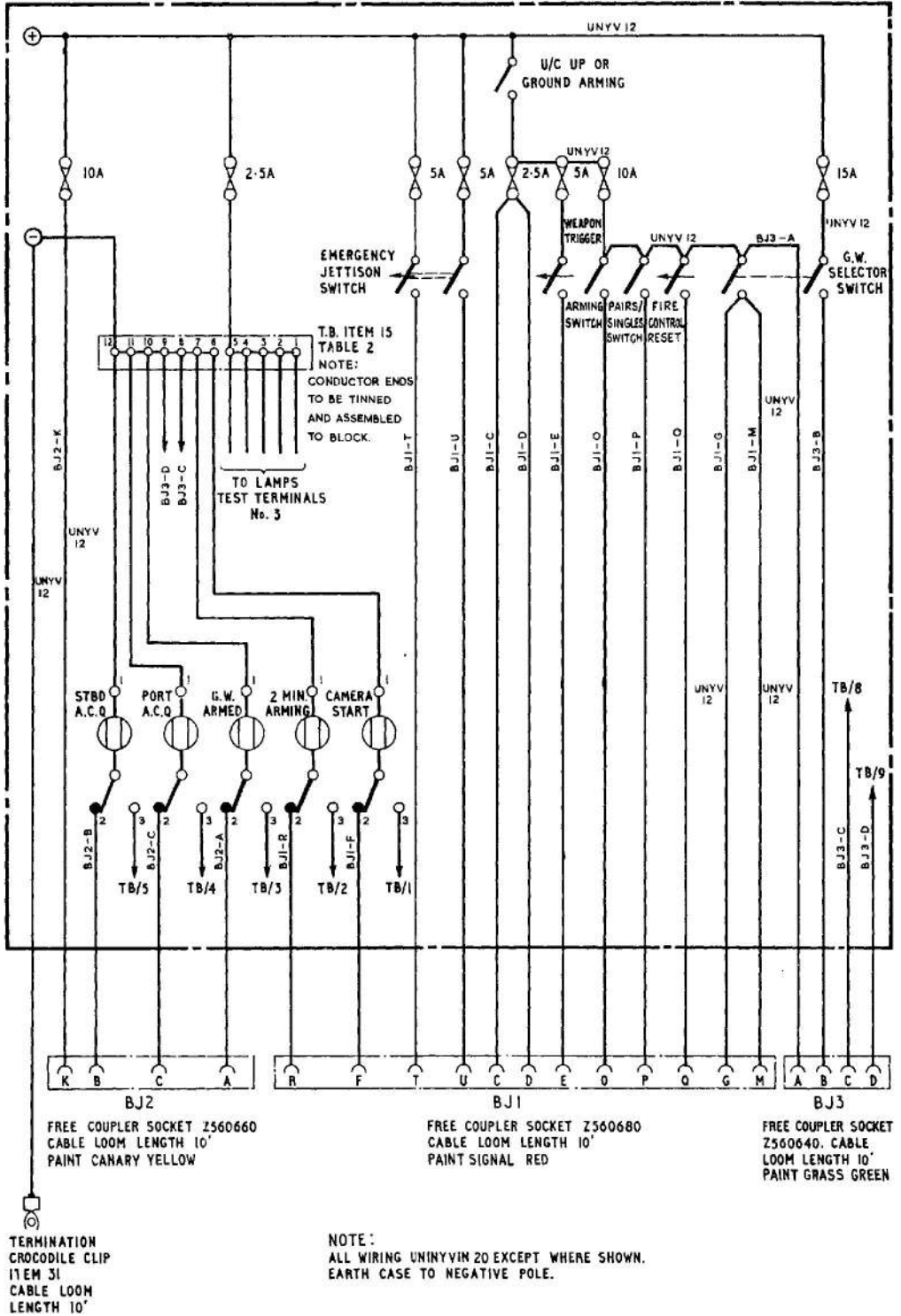

Fig. 5. Circuit Diagram

RESTRICTED

and fit appropriate free coupler socket accessories.

- (4) Solder cables to free coupler sockets.
- (5) Cut P.V.C. sheathing to 10 ft. lengths.
- (6) Position socket accessories, slide P.V.C. sheathing over cables and fit coupler socket clamps to secure P.V.C. sheaths. Fit protective caps to sockets.
- (7) Feed connectors through the respective cable outlet plates of the rear panel. Fit clamps over P.V.C. sheaths and secure.
- (8) Fit a crocodile clip to one end of an 11 ft. length of Vin. 12 cable. Feed the other end of the cable through a 10 ft. length of P.V.C. sheathing and then through the grommet in rear panel. Ensure sheathing protrudes at least 1 in. from panel inside face.
- (9) Attach insulating sleeve and termination to cable.
- (10) Connect cable to negative terminal.

Wiring

9. Refer to Fig. 5 when connecting the cables of the test set and to Table 5 for details of cable connections. When routing and connecting cables within the test set allow sufficient spare in the cables to facilitate possible future servicing. Arrange the cables neatly in looms running down the rear panel, across the bottom of the test set and up the front panel.

- (1) Lay the front panel, face down, with its lower edge near the lower edge of the front of the case.
- (2) Position the rear panel in a similar manner at the rear of the case.
- (3) Cut to length each cable, route and connect as shown in Fig. 5, fitting sleeves to the cable ends.

Note . . .

Item 6, Table 5 is used when connecting Vin. 12 cable to switches.

- (4) Mark sleeves as shown in Fig. 5.
- (5) Loom cables using Item 9, (Table 5).

Final assembly

10. Complete the assembly of the test set as follows:—

- (1) Accurately position the rear panel against the wooden case and secure with wood screws.
- (2) Repeat this procedure for the front panel.
- (3) Fit fuses and filament lamps.

Electrical check

11. On completion of the assembly of the test set, a check should be made to ensure that it has been correctly wired and that all components are functioning correctly.

- (1) Connect a 28V d.c. supply to the terminals on the rear panel.
- (2) Depress each indicator lamp in turn and check that the lamps light. (The maximum current drawn from the test set when testing a weapon pack is less than 6 amps.: however, self-testing draws less than 1 amp.)
- (3) Make up a test lamp (24V, 2.4W) with leads, approximately 1 ft. long.
- (4) Connect one lead to the test set negative terminal.
- (5) Referring to Fig. 5, connect the other test lead in turn to the free coupler sockets and check that the test lamp lights when the appropriate switch is closed.

SERVICING

12. Servicing of the test set may be confined to replacement of defective components. Fuses of the correct rating should always be fitted since they protect circuits in the weapon pack under test rather than the test set.

TABLE 1
Test set case components

Item	Ref. No.	Nomenclature	Qty.	Remarks
1	Loc. Man.	Case	1	$\frac{1}{2}$ in. Deal (31B/140)
2	10AK/505	Handle	1	
3	Loc. Man.	Ident. Label	1	Paxolin $4 \times 1 \times \frac{1}{16}$ in. (5F/9400950 Fabric, synth. resin bonded sheet $\frac{1}{16}$ in. thick)
4	28S/2091	Screws, CA/HD, 4 BA $\frac{7}{8}$ in. long	4 } 4 } 4 }	To secure handle to case.
5	28M/5665	Nuts, 4 BA		
6	28W/12676	Washers		
7	28S/2282	Screws, Wood, No. 6	4	To secure ident. label.
8	33B/9428868	Varnish, Shellac		Finish of case.

TABLE 2
Front panel assembly components

Item	Ref. No.	Nomenclature	Qty.	Remarks
1	30B/2023	Sheet, metal aluminium	1	$15\frac{3}{4}$ in. + 10 in. 12 gauge
2	5CX/4538	Indicator, lamp (red)	5	
3	5CX/5341	Windows, clear	3	
4	5CX/5443	Windows, green	1	
5	5L/9959213	Lamp filament 24V. 2.4W	5	
6	5CW/5271	Switch S.P. sprung to OFF N.S.F.	2 } 1 }	Complete with locking rings
7	5CW/5274	Switch D.P.S.T. ON-OFF N.S.F.		
8	10H/0510505	Switch D.P. sprung to OFF N.S.F.	1	
9	5CW/6813	Switch S.P. ON-OFF N.S.F.	3	
10	5CX/5676	Holder fuse standard	7	Or equivalent. Complete with attachment nuts
11	5CZ/5215	Fuze 5A	3	
12	5CZ/5216	Fuze 10A	2	
13	5CZ/5214	Fuze 2.5A	2	
14	5CZ/5217	Fuze 15A	1	

RESTRICTED

Table 2—cont.

Item	Ref. No.	Nomenclature	Qty.	Remarks
15	5CZ/5099	Terminal block flexible	1	
16	28S/2146	Screw C/SK 6 BA $\times \frac{7}{8}$ in. long	2	To fasten Item 15
17	28M/5666	Nuts 6 BA	2	} To attach Item 15 and } Item 2 (Table 3)
18	28W/14033	Washers 6 BA	2	
19	28S/8875	Screws, self tapping	38	For attachment of components ident. strips
20	5F/9400950	Fabric, synth. resin bonded sheet $\frac{1}{16}$ in.	As rqd.	For making up component ident. strips

TABLE 3
Rear panel assembly components

Item	Ref. No.	Nomenclature	Qty.	Remarks
1	30B/2032	Sheet, metal alluminium alloy	1	15 $\frac{3}{4}$ in. \times 10 in. 12 gauge
2	5X/6605	Ferrule plate assembly. Size B	3	
3	5P/2659	Terminal Red +	1	} Complete with attachment } nuts
4	5P/2660	Terminal black—	1	
5	5CX/5676	Holder fuze standard	7	Complete with attachment nut
6	Loc. Man.	Label, filament test fuze	1	Paxolin $4 \times \frac{3}{4} \times \frac{1}{16}$ in. (5F/9400950 fabric synth. resin bonded, sheet, $\frac{1}{16}$ in. thick)
7	Loc. Man.	Mod. label	1	Paxolin $2\frac{1}{2} \times 2\frac{1}{4} \times \frac{1}{16}$ in. (Material as for 6)
8	5X/3666	Grommets Helvin	1	
9	28S/14237	Screw, RD/HD 6 BA $\times \frac{1}{8}$ in.	18	
10	28M/5666	Nuts, 6 BA	18	} For attachment of 7 and 5 } (Table 2), and 5 (Table 3)
11	28W/14033	Washers, 6 BA	18	

RESTRICTED

TABLE 4
Connector components

Item	Ref. No.	Nomenclature	Qty.	Remarks
1	10H/0560680	Free coupler socket	1	} Part of BJ connector
2	10H/0970067	Outlet straight	1	
3	10H/0970296	Clamp	1	
4	10H/0970060	Outlet gasket	1	
5	10H/0970092	Ring sealing	1	
6	10H/0970098	Ring thrust	1	
7	10H/0970104	Ring compression	1	
8	10H/0970110	Gasket union	1	
9	10H/0970057	Cap protective	1	
10	10H/0970116	Sleeve cable	1	
11	10H/0560660	Free coupler socket	1	} Part of BJ 2 connector
12	10H/0970065	Outlet straight	1	
13	10H/0970294	Clamp	1	
14	10H/0970099	Ring thrust	1	
15	10H/0970105	Ring compression	1	
16	10H/0970111	Gasket union	1	
17	10H/0560640	Free coupler socket	1	} Part of BJ 3 connector
18	10H/0970063	Outlet straight	1	
19	10H/0970295	Clamp	1	
20	10H/0970097	Ring thrust	1	
21	10H/0970103	Ring compression	1	
22	10H/0970109	Gasket union	1	
23	10H/0970059	Outlet gasket	2	} Part of BJ 2 and BJ 3 connectors
24	10H/0970089	Ring sealing	2	
25	10H/0970056	Cap protective	2	
26	10H/0970115	Sleeve cable	2	
27	5E/4183	Cable L.T. Uninyvin 20	65 yds	} Used with BJ 1, BJ 2 and BJ 3
28	5E/4187	Cable L.T. Uninyvin 12	26 yds	
29	5F/2037	Tubing synthetic $\frac{3}{4}$ in.	10 yds	
30	5F/2143	Tubing synthetic $\frac{1}{4}$ in.	10 ft	Used with negative pole connection
31	5J/3124	Clips, crocodile	1	Terminates negative pole connection to pack
32	5K/9107065	Sleeve binding pink $\frac{3}{4}$ in.	As reqd	} Used with BJ1, BJ2 and BJ3
33	5X/6489	Clamp ring, size C	3	

RESTRICTED

TABLE 5
Miscellaneous wiring accessories

Item	Ref. No.	Nomenclature	Qty.	Remarks
1	5E/4183	Cable, L.T. Uninyvin 20	10 yds	
2	5E/4187	Cable, L.T. Uninyvin 12	5 yds	
3	5K/9107065	Sleeve binding pink, $\frac{3}{4}$ in.	As reqd.	
4	5X/6815	Termination ring tongue	1	} Terminates 20V in cable
5	5X/6869	Termination ring tongue	1	
6	5X/9400388	Termination lug crimping	8	} Terminates 12V in cable
7	5X/9500390	Termination lug crimping	1	
8	5X/9400391	Termination lug crimping	1	
9	32A/9429657	Cord, lacing, Nylon 1 mm.	As reqd.	Looming

This file was downloaded
from the RTFM Library.

Link: www.scottbouch.com/rtfm

Please see site for usage terms,
and more aircraft documents.

