

PART III

MANAGEMENT OF SYSTEMS AND USE OF EQUIPMENT

59. Management of the fuel system

- (a) (i) The L.P. and H.P. cocks must be ON and except for starting, and taxiing after landing, the booster-pump switches should be ON (modified aircraft) or at AUTO or MANL (unmodified aircraft) at all times when the engine is running.
- (ii) After starting check that with both booster-pumps switches off, the low pressure indicator shows white. Then ensure that as each switch is set in turn to AUTO and MANL (ON in aircraft fitted with fuel proportioner) the low pressure indicator shows black. Leave at AUTO (or ON). On aircraft fitted with booster-pump failure warning lights, switch ON each pump and check that the lights go out; the L.P. indicator should be black with booster-pumps ON or OFF.
- (b) *Aircraft with fuel proportioner*
With the booster-pump switches ON equal flow should be provided from both front tanks.
- (c) *Aircraft with fuel balancing*
- (i) With booster-pump switches set to AUTO, fuel balancing will only function when the gauge readings begin to fall.
- (ii) In aircraft with wing tank fuel ungauged with the switches at AUTO all the fuel from one wing tank plus a small amount from the centre tank on the same side will be used before the gauge senses that one side is low and causes that booster-pump to operate at reduced output. Fuel is then fed from the other side. The asymmetric flow is indicated by a gradual wing-low effect which, in Power, is hardly noticeable. (See para. 96 (c).)

(iii) When drop tanks are carried the booster pump switches should be set to MANL until either fuel gauge starts to show a drop, then set to AUTO. This is to avoid the out-of-trim effects which will occur due to the asymmetric fuel flow described in (ii) the effects of which in this case will be of greater magnitude.

(d) *Unusable fuel (all aircraft)*

- (i) Provided that slow forward throttle movements and small changes in attitude are made the engine will continue to run satisfactorily down to zero gauge readings, but at low fuel states steep climbs and/or sudden application of full power should be avoided particularly when overshooting, as this will cause fuel in the tanks to move away from the booster-pumps resulting in possible fuel starvation and flame extinction. Therefore at low fuel states minimum power consistent with safety should be used, steep attitudes avoided and a glide approach planned. If flame-out occurs, a relight may be obtained by adopting a nose-down attitude and pressing the relight button.
- (ii) The amount of unusable fuel increases with sudden forward acceleration and/or nose-up attitude: rig tests reveal the following:—

Angle between fuel surface and fuselage datum	Unusable fuel lb. per side
10°	125 lb.
20°	200 lb.
30°	230 lb.

On a normal take-off, the angle between fuel surface and aircraft datum is approx. 23°, at which angle approx. 210 lb. per side are unusable.

(e) *Unequal tank emptying*

- (i) Unequal emptying to the extent of 100 lb. or more will result from either balance control failure or booster-pump failure. The contents gauges and booster-pump failure warning lights (when fitted) should be checked frequently to ensure that fuel balancing is being maintained. If a booster pump

fails any resulting inequality in fuel levels cannot be corrected. Both pumps should therefore be turned off (see (f) below).

- (ii) To check for booster-pump or balance control failure in aircraft without booster-pump failure warning lights, switch off the pump on the low contents side; if the low pressure warning indicator then shows white the "high-side" booster-pump has failed, if it remains black automatic balancing has failed. If the latter occurs balancing must be then obtained by use of the individual booster-pump switches between the MANL and OFF positions (or ON and OFF positions in aircraft fitted with a proportioner) i.e. switching off the pump on the low contents side until the fuel contents are level, then switching both pumps to MANL (or ON in modified aircraft).
- (iii) With the booster-pump failure warning lights fitted the operating pressure of the low pressure warning indicator is reduced to 3½ lb./sq. in. It will not go white when both booster-pumps are off; in this case balance control failure is indicated by unequal emptying with the booster-pump failure lights out.

A.L.1
Para. 59
(f) (i)
Page 51

(f) *Booster-pump failure*

- (i) If a booster-pump fails, indicated by a warning light coming on and the corresponding contents gauge reading high, no fuel will be used from that side if the serviceable pump is left on; in this event reduce r.p.m. to 7,200, and reduce altitude to the limits below according to the aircraft configuration.

With drop tanks 20,000 feet max.

Without drop tanks 25,000 feet max.

Then switch off both pumps and accept the fuel feed provided by tank pressurisation and gravity. R.p.m. must thereafter not exceed 7,200. The altitude limit may be increased in emergency by 10,000 feet if absolute range is essential, but in this event the engine must subsequently be examined for possible damage to the fuel system.

- (ii) With both booster-pumps off, negative G manoeuvres must be avoided. It is important to land while both sides still contain fuel, because the flow proportioner will maintain out-of-balance levels and the engine will not run with one side empty unless the booster-

PART III—MANAGEMENT OF SYSTEMS

- (ii) pump in the side containing fuel is serviceable. The serviceable pump may be switched on for a landing if a sufficient head of fuel remains on that side, but it should be remembered that with the pump on, fuel will only be used from that side.

(g) *Transfer failure*

- (i) The fuel transfer indicators should remain black throughout the flight. If one or both show white, air pressure failure has occurred and steep dives should be avoided due to the possibility of collapsing the tanks. Should an indicator show white before transfer is complete, any fuel remaining in the rear and centre tanks will be unusable and the associated contents gauge will only indicate the fuel in the front tanks (775 lb. max. per tank). In these circumstances if the gauge registers more than the total contents of a front tank a faulty gauge should be suspected and only the front tank fuel should be relied on as being available to the engine. The booster-pump on the side with air transfer failure should be switched OFF until the contents gauge of the other side indicates an equal amount; then reset the switch to AUTO (unmodified aircraft), or ON (modified aircraft).
- (ii) A fuel transfer indicator may show white when the rear and wing tanks are empty or nearly empty. This is caused by the hydraulic valve freezing. If it occurs only the fuel in the front tanks will be available to the engine. Since this only occurs when all or nearly all the fuel from the wing and rear tanks has been transferred it is not serious from fuel point of view; rapid ~~climbs and~~ descents should however, be avoided, otherwise the fuel tanks may collapse.

(h) *Gauge failure*

- (i) *Aircraft with fuel proportioner*
Total or partial gauge failure will not affect fuel flow. Check that neither booster-pump nor transfer failure has occurred, leave both pumps ON and return to base.
- (ii) *Aircraft with fuel balancing*
Total or partial gauge failure will quickly result in an out of balance fuel state. Switch both pumps to MANL and return to base.

PART III—MANAGEMENT OF SYSTEMS

(j) *Fuel gauge errors*

When gauges are fitted which read the contents of the wing tanks, they have been found to give erroneous indications due to temperature effects on the electrical wiring. The magnitude of the error depends on both temperature and time. Low temperatures at high altitude give gauge under-reading; high temperatures at high speeds at low altitude give gauge over-reading. During a descent from altitude, if the gauges are under-reading, the gauges will become progressively more accurate and may eventually tend to over-read.

60. **Engine handling**

(a) *On take-off*

An acceleration effect on the r.p.m. indicator during take-off may cause the engine speed to under-read by up to 100 r.p.m. This coupled with the effect mentioned in (c) below may cause the r.p.m. at the start of the climb to read as much as 150 less than the static ground figure. This effect should gradually disappear as the climb progresses.

(b) *On the climb*

- (i) During a climb to 45,000 ft. at full throttle the governed r.p.m. may increase by up to 100. This increase may cause the j.p.t. to exceed the limitations unless the throttle setting is reduced. It should not be necessary to reduce r.p.m. to below 8,000 (7,900 Avon 115) to keep the j.p.t. within limits.
- (ii) At intermediate throttle positions different combinations of forward speed and ambient air temperature may cause r.p.m. to vary from those selected by plus 300 to minus 150.

(c) *High airspeed at low altitude*

High forward speeds at low altitude may reduce the maximum attainable r.p.m. by as much as 100. Damage to the engine may result, if the throttle is closed too rapidly at high airspeed.

(d) *Engine surges*

If, when increasing to max. r.p.m. or under continuous r.p.m. conditions the engine shows any sign of excessive

j.p.t. or instability, i.e. a rapid drop in r.p.m. and/or a general rumbling accompanied occasionally by a loud bang, close the throttle immediately to reduce the possibility of flame-out and dive the aircraft. Re-open the throttle slowly and smoothly, checking engine response. Repeat this drill until engine response returns to normal. Do not assume flame-out has occurred unless r.p.m. fall below 3,000. (See para. 99.) This type of surge is only likely to occur at high altitudes, low airspeed and temperature conditions of less than -50°C . A surge may also occur at altitude at higher airspeed when positive G is applied.

A.L.1
Para. 60
(e) (i)
Page 54

(c) *Governed r.p.m.*

- (i) The engine is governed at 8,100 r.p.m. (Mk. 115-7,950 r.p.m.) at which speed maximum thrust is obtained. At low air temperatures the engine may underspeed on take-off to as low as 8,000 r.p.m. (Mk. 115-7,800 r.p.m.) at full throttle whilst still maintaining maximum thrust. Below are the relevant figures.

Temp. °C.	Avon 121	Avon 115
	R.p.m.	R.p.m.
+15	8,100	7,950
0	8,085	7,935
-10	8,070	7,920
-20	8,035	7,885

It will be seen that in temperate climates the r.p.m. at take-off should not be lower than 8,020, i.e. 8,070-50 tolerance. (Mk. 115-7,870, i.e. 7,920-50 tolerance.)

- (ii) Governed r.p.m. may also be reduced in flight without loss of thrust if the top temperature limiter comes into operation.
- (f) *Fuel dipping and air bleeding—Mk. 121*
Above 20,000 feet, when the gun firing button is pressed the r.p.m. will drop. The amount of this r.p.m. drop is dependent upon the initial r.p.m. the altitude, the length of burst, and the airspeed. Just before or when the firing button is released the r.p.m. should return to the original figure.

61. **Management of the pressurization and flood flow system**

NOTE.—Pending modification action to improve the system, MANUAL flood control must not be selected below 15,000 ft. at r.p.m. exceeding 7,000. When Mods. 209, 291, 321, 322 are all incorporated, all restrictions on the use of the system are removed.

- (a) For all normal conditions of flight the FLOOD AIR-FLOW CONTROL switch should be at AUTO. To prevent windscreen misting MANUAL should be selected:—
- When cruising for prolonged periods at high altitude and low engine r.p.m., e.g. more than 15 minutes above 30,000 ft. at 7,200 r.p.m. or less (see (b) below).
 - For descents using less than 7,000 r.p.m. after high altitude cruising until misting has cleared or misting danger has passed. (See (c) below and NOTE.)
- (b) If misting occurs above 30,000 ft. when cruising at 7,200 r.p.m. or above, keep both the FLOOD AIR CONTROL and the CABIN TEMP. CONTROL switches at AUTO and select full heat on the CABIN TEMP. SELECTOR.
- (c) If descending with r.p.m. above 7,000 keep the FLOOD AIR CONTROL switch at AUTO and select HOTTER on the CABIN TEMP. CONTROL.
- (d) *Pressurization system*
Before start up, check the cockpit pressure warning light comes on by operating the cockpit pressure warning test switch to TEST. Then return the switch to NORMAL.
- (e) The cockpit pressurization switch should be ON for take-off, but if due to high humidity, misting occurs or vapour issues from the gallery pipes, it should be switched OFF until 5,000 feet is reached.

62. **Management of the engine anti-icing system**

NOTE.—1. The system should be regarded as a means of protection during climb and descent only and is not designed for prolonged use in level flight.

2. With the system in operation a loss of thrust and fuel economy will occur. At full throttle it may be necessary to reduce power to keep the j.p.t. within limits.

PART III—MANAGEMENT OF SYSTEMS

Page 56
Para. 62
(cont'd.)
A.L.2

3. The information below applies to the Mk. 115 engine. When the Mk. 121 engine is fitted, the system may be switched ON or OFF at any r.p.m. above 5,500. When the system is in use r.p.m. must be maintained above that figure. During a descent the maximum anti-icing protection is achieved at the highest practicable r.p.m.

(a) *Ground running*

In conditions of fog or mist at OAT's below +5° C. switch ON anti-icing immediately after starting. Taxi, and, if runway length permits, take-off with the system ON; otherwise run the engine at 7,000 r.p.m. for one minute immediately before take-off and then switch the system OFF. Switch the system ON again as soon as possible after take-off and do not switch it OFF until 2 minutes after icing conditions cease to exist.

NOTE.—Do not carry out any acceleration checks with the system ON.

(b) *Level flight*

Climb or descend out of the icing level.

(c) *Climb*

Open the throttle to the desired r.p.m. and when above 7,200 switch ON the system. Avoid unnecessary throttle movements (which if essential must always be made slowly). Switch OFF the system when clear of icing.

(d) *Descent*

Reduce r.p.m. to 6,100 and switch ON the system. Descend as quickly as possible. R.p.m. between 5,800 and 6,600. When clear of icing switch OFF the system and allow 10 seconds before making any large throttle movements. Check engine response before landing.

(e) *Landing*

If icing conditions persist down to airfield level, engine r.p.m. must be maintained above 5,800 until finally committed to a landing. If an overshoot is necessary, open the throttle as slowly as possible.

63. Management of the powered flying controls

(a) *Ailerons and elevator*

- (i) After starting select the power control switches to ON and engage the controls by moving the control column through its full traverse (using two hands if necessary) until free movement is felt. Check the magnetic indicators go black.
- (ii) If Mod. 452 is incorporated, hold the selector switch to POWER with the left hand and move the control column with the right hand, laterally when engaging ailerons and fore and aft when engaging elevator, until the corresponding magnetic indicator goes black. The switch can then be released. To engage aileron power more easily it is advisable to either:—

PART III—MANAGEMENT OF SYSTEMS

1. Select POWER ON with the stick held hard over to starboard, then move it to port, or
2. Attempt the engagement immediately after light-up before hydraulic pressure builds up.

If Power has not been correctly engaged the controls will revert to Manual when the switch is released.

- (iii) Immediately before take-off check that the magnetic indicators are black at not less than 4,500 r.p.m.

WARNING.—At any other stage of a flight, if either automatic Manual reversion or any form of stick jamming occurs with Power selected ON, immediately switch Power OFF. Do not attempt to re-engage Power; return to base and land in Manual.

(b) *Clearing false anchorages (ailerons)*

NOTE.—The information concerning false anchorages applies mainly to aircraft without Mod. 452. When this mod. is embodied false anchorages can still occur when re-engaging Power in the air only so long as the selector switch is held at POWER ON.

- (i) When a reselection to Power is made in the air, it is possible that the locking pawls will not engage in the slots on the piston rods, but merely clamp on the side of the rods giving a false anchorage; the magnetic indicators remain white. False anchorages can be caused by the pistons "creeping" to full travel during a lengthy period of Manual flying or when the ailerons are deflected appreciably either by the control column or by the presence of aileron up or down float when selecting Power ON or OFF. False anchorages can give two types of restriction. (See (c) and (d).)
- (ii) If power is reselected below 10,000 ft. and a false anchorage occurs, immediately switch Power OFF and either

1. Return to base and land in Manual, or
2. Climb above 10,000 feet before making any further attempt to re-engage Power.

WARNING.—1. If it is not possible to clear a false anchorage, select Power OFF. Return to base and land in Manual.

2. If, when Manual is selected following a false anchorage, the controls remain jammed (indicating that Manual re-selection is impossible) the aircraft must be abandoned.

(c) *One-way restriction*

- (i) This usually occurs as a result of reselecting Power with the ailerons deflected, e.g. when initiating a turn. The locking pawls clamp on the side of the piston rods in opposite senses relative to the slots, e.g. one rod extended the other retracted. There will be apparent power-operated movement in one direction due to the clamping of the pawls on the rods. Movement of the control column in the other direction is restricted since power assistance is not available and not only has the friction clamp of both pawls to be overcome but the ailerons have to be deflected manually. This type of restriction can also occur as a result of having one pawl correctly engaged and one pawl out of engagement. Correct engagement of the pawls can be obtained by demanding a force greater than that which can be held by pawl friction, thus causing the piston rods to slide.

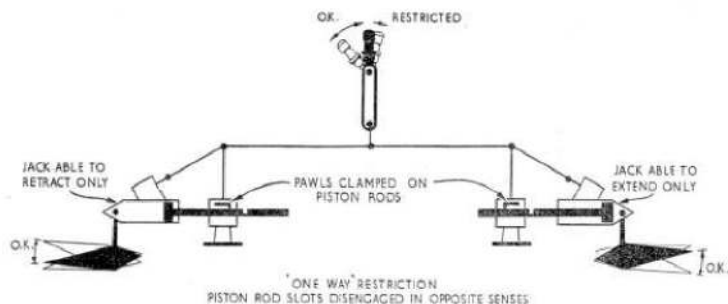

- (ii) If Power is reselected above 10,000 ft. and a one-way restriction occurs, it may be cleared as follows:—

The control column should be moved rapidly over its full movement in the direction of unrestricted travel. If the airspeed is below 250

knots, this can be done without producing excessive aircraft roll.

(d) *Both-ways restriction*

- (i) This usually occurs as a result of reselecting power ON with the ailerons floating up or down, e.g. when easing out of a dive. The pawls will grip the piston rods in the same sense relative to their slots, e.g. both rods extended or both retracted, giving complete jamming of the control column in the neutral position. Movement of the control column in either direction is restricted by the friction clamp of one pawl and the ailerons having to be deflected manually.
- (ii) If Power is reselected above 10,000 feet and a both-ways restriction occurs it may be cleared as follows:—

Lower full flap at an airspeed of 250 knots, and select aileron Power ON (or hold switch at POWER ON if Mod. 452 is incorporated). The aileron buffet which occurs in this configuration will probably be sufficient to enable the pawls to engage in the slots, but if necessary move the control column laterally until the magnetic indicator turns black.

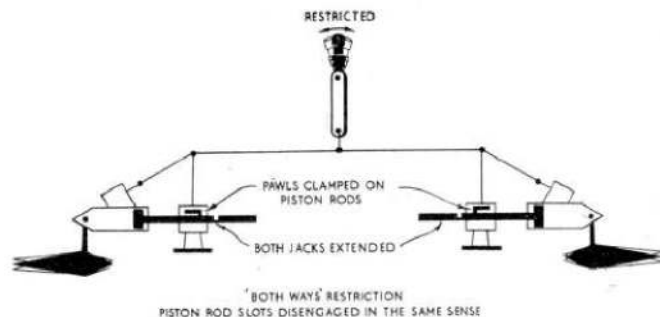

(e) *Follow-up tailplane*

- (i) After starting, check the tailplane switch is OFF. Note the trim position on the tailplane incidence indicator and trim to a new position at least 1° different. Switch the TAILPLANE ON. Check that the tailplane does not move from the new position.

Move the stick fore and aft and check that the tailplane follows up. If the emergency switch cover is lowered after checking the emergency switch, with the tailplane at a different angle from that when the cover was raised, the tailplane will revert automatically to the original trim angle.

Page 60
Para. 63
(e) (ii)
A.L.3

- (ii) If the follow-up tail malfunctions, either in its capacity as a flying control or in its trimming action, the standby trim switch cover must be lifted immediately. The standby actuator can then be used to obtain satisfactory trim. It is possible that the malfunction may not affect the main trim actuator with TAILPLANE selected OFF although it might have shown itself during either normal control movement or trimming with TAILPLANE ON. After raising the standby trim switch cover, select TAILPLANE OFF, then reselect the main actuator and check the normal trimming action. If the malfunction is still present, revert to the standby actuator and return to base.
- (iii) If the tailplane trim actuator runs away, lift the standby trim switch cover. If this fails to stop the runaway trip the tailplane main actuator circuit breaker; control can then be regained by use of the standby trim switch. When Mod. 907 is embodied lifting the standby trim switch cover will trip the main circuit breaker.

64. Management of the electrical system

(a) Testing the standby A.C. inverter on the ground

To test the standby inverter, first check that the engine master switch is OFF and then set the battery master switch ON, the inverter test switch to NORMAL (inboard) the inverter circuit breakers in and then move the RADAR TEST switch to TEST. The inverter can then be heard to operate and the artificial horizon can be seen to erect. When the test is complete return the radar test switch to OFF.

(b) Electrical system failures

(i) Single generator failure

If either generator fails, the output of the other is sufficient for non-combat flying provided that all non-essential electrical services are off and that engine r.p.m. are maintained above 4,000. When the follow-up tailplane is in use an additional heavy electrical load is imposed; use of the interconnection should therefore be limited to manœuvring at speeds above 0.9M.

(ii) Double generator failure

If both generators fail, all electrical services will be supplied by the batteries. These, if fully charged, will maintain the following output before they fail (i.e. battery voltage below 16 volts).

Output—Amps	150	125	100	75	50	38	25
Time—Mins.	1½	2	3	5	10	18	40

These figures apply to aircraft with two 12-volt batteries. On aircraft with two 24-volt batteries the times should be doubled. To assist the pilot in deciding which loads should be shed, if generator failure occurs, the following table lists the major services and the current they require.

Service	Load (amps.)	Service	Load (amps.)
Booster pumps	35	Pressure head heater	6
Radar ranging	30	Starter control	6
A.C. inverters	15	(relighting)	
Tailplane actuator	12	Fuel contents gauge	4.5
Hood control	10	G.G.S.	4
V.H.F. sets	7.5	G.G.S. retraction	3.5
I.F.F. set	6.5	All other electrics	10
D.M.E.	6		
		Maximum flight load	156

NOTE.—The average flight load is 105 amps.

(c) Double generator and battery failure

Once the batteries are discharged, no electrical services may be operated, e.g. trim tab actuators, tailplane motors, electro-hydraulic selectors, etc. If the flying controls are in Power, selection of Manual will not be possible unless Mod. 502 has been embodied, in which case Manual may be selected by pushing the emergency selector buttons. In addition the fuel gauges, Mk. 4F compass and electrically-operated flight instruments will become unserviceable. The fuel booster-pumps will cease operation, which may entail reduction in altitude and engine r.p.m. to ensure satisfactory engine running. (See para. 59 (f) (i).) No relight facilities will be available when the batteries are fully discharged.

65. Use of ejection seat equipment

WARNING.—1. The pilot must ensure that each safety pin is removed and stowed before flight. He must also ensure, before leaving the cockpit after flight, that each handle is locked against the possibility of accidental withdrawal on the ground by passing the appropriate safety strap through its associated handle and securing it with its spring safety pin. All personnel must ensure that both firing handles are locked before entering the cockpit.

2. If it is necessary to leave the aircraft in an emergency on the ground, special care must be taken not to foul the secondary firing handle (on the seat pan) if its safety strap and pin are not in position.

The safety of the pilot on ejection depends primarily on the correct use of his equipment. The following drill should therefore be followed carefully when preparing for flight.

- (a) Adjust the height of the seat.
- (b) When seated, connect the dinghy lanyard to the life-saving waistcoat, ensuring that the quick release is below the parachute waist-belt. Secure the parachute harness.
- (c) Fasten the safety harness lap-straps and then, if fitted, secure the leg restraining cords as follows:—
 - (i) Secure the leg straps below the knees with the D-rings to the rear.
 - (ii) Pass the left nylon cord through the right-leg D-ring under the safety harness lap straps and insert the right shoulder harness eye-piece through the loop on the cord. Secure the shoulder harness in the quick release box.
 - (iii) Repeat for the other cord, passing the right cord through the left-leg D-ring and attach the loop to the left shoulder harness. Secure the harness.
- (d) Have the ejection seat safety pin(s) removed and stowed.

- (e) Connect the main oxygen and emergency oxygen supply tubes to the oxygen mask tube and the locating chain to the life-saving waistcoat. To prevent possible entanglement, ensure that the emergency oxygen tube is connected under the seat safety harness but above the parachute harness.
- (f) Connect the mic/tel lead.
- (g) Check that the firing handle can be reached with both hands together. *Do not pull.*

This file was downloaded
from the RTFM Library.

Link: www.scottbouch.com/rtfm

Please see site for usage terms,
and more aircraft documents.

