

Chapter 2

MAIN PLANES

LIST OF CONTENTS

| | Para. | | Para. |
|---|-------|-------------------------------|-------|
| Introduction | 1 | Aileron operating gear | 9 |
| Description and operation | | Wing tip | 10 |
| General | 2 | Flaps | 11 |
| Outer wings | 3 | Ailerons | 12 |
| Spars and undercarriage girder | 4 | Servicing | |
| Trailing edge and aileron shroud | 5 | General | 13 |
| Fuel tank compartments | 6 | Lubrication | 15 |
| Pylon attachments | 7 | Removal and assembly | |
| Universal pylons | 8 | General | 16 |

LIST OF ILLUSTRATIONS

| | Fig. | | Fig. |
|--|------|---|------|
| Outer wing | 1 | Removing aileron | 11 |
| Removing wing | 2 | Outer hinge | 12 |
| Connections at front spar (port) | 3 | Centre hinge | 13 |
| Connections at front spar (starboard) | 4 | Inner hinge | 14 |
| Connections at rear spar (port) | 5 | Removing flaps | 15 |
| Fuel pipe connections forward of front spar | 6 | Operating jack attachment | 16 |
| Details at rear spar joint | 7 | Synchronizing jack attachment | 17 |
| Undercarriage up-lock tool | 8 | Drum switch, etc., control rod attachment... .. | 18 |
| Sling attachment | 9 | Removing wing tip and pressure head | 19 |
| Locating spigot and socket | 10 | Removing universal pylon | 20 |

Introduction

1. This chapter contains a general description of the main plane structure, together with the lubrication and other servicing information necessary to maintain it in an airworthy condition. Illustrations showing the method of jacking, slinging and dismantling the structure into its major components are also included.

DESCRIPTION AND OPERATION**General**

2. The main plane is built in three sections, a stub wing, which is integral with the centre

fuselage, and port and starboard outer wings. The outer wings are of swept-back design with slight negative dihedral and carry the wing fuel tanks, universal pylons and the main undercarriage. The wings incorporate conventional ailerons and split trailing edge flaps, the ailerons being provided with power-operated controls, or hydroboosters, which facilitate their operation at high speeds. The stub wing structure is described in Chapter 1 of this section.

Outer wings (fig. 1)

3. Each outer wing is an all-metal stressed

skin cantilever structure consisting of leading edge, front and rear spars, an undercarriage girder, nose ribs, inter-spar ribs and tail ribs covered with a heavy-gauge light-alloy skin which is additionally strengthened by stringers and stiffeners; a detachable wing tip completes the structure. Ribs A, G, M and R are of heavier construction than that of the remaining ribs, and with the front spar, undercarriage girder and rear spar they form the major framework of the outer wing. The wing fuel tanks are carried forward of the front spar in compartments formed between nose ribs A and G, the nosing of the wing over this portion is removable to gain access to these tanks. The universal pylons are bolted to the underside of the wing just outboard of the fuel tank compartments.

Spars and undercarriage girder

4. Both spars are fabricated in three portions, but are continuous when assembled, and both inboard ends of the inner portions carry the high-tensile wing attachment fittings which pick up with fittings on the fuselage stub wing frames. The undercarriage girder is attached to the inboard end of the rear spar and extends outwards and forwards to inter-spar rib G, thus forming a box-like structure between the two spars in which the main undercarriage is housed when retracted. The undercarriage pivot block is accommodated at the outboard end of this structure, being attached to the front spar, inter-spar rib G and the undercarriage girder.

Trailing edge and aileron shroud

5. The trailing edge structure, aft of the rear spar, consists of a number of tail ribs extending from the wing root to the aileron shroud. These ribs are recessed to form the flap housing, the flap being mounted on bearing brackets located between tail ribs A

and C, at rib E, between tail ribs F and G and at rib L. The aileron shroud structure extends from tail rib M to the outer rib and is attached to the rear spar. Rib M carries the aileron inner hinge, the outer rib carries the outer hinge and the centre hinges are mounted on the shroud structure.

Fuel tank compartments

6. The flexible-bag type fuel tanks in each outer wing are contained in four compartments formed between the leading edge and front spars in the region of ribs A to G. These compartments are sealed from the remaining structure and each other by moulded packing attached to the ribs and spars, and are provided with internal skinning to support the tanks. The leading edge nosing forward of these compartments is detachable to provide access to the tanks and consists of a curved light-alloy shell stiffened by a number of dished nose ribs. The nosing is attached to the top and bottom booms of the leading edge spar and to nose ribs extending forward from this spar.

Pylon attachments

7. Each universal pylon is bolted to the underside of the outer wing forward of the front spar in the region of nose ribs G to J and the internal structure of the wing in this region is strengthened by spanwise ribs located just aft of the nosing, and by reinforcing plates on the lower skin between the nose ribs. Eleven machined stampings in the form of mounting brackets with nut plates attached are riveted to the sparwise ribs and nose ribs H and J. The universal pylon is bolted to these mounting brackets by special bolts extending through the top member of the pylon and wing skin, to engage with the nut plates on the mountings. Holes cut in the lower skin and suitably reinforced are provided to give access to the fuel pipes, electrical cables, etc., extending between the wing and pylon.

Universal pylons

8. One universal pylon is attached to each wing and is designed to carry either a bomb

or a drop-tank. The structure of the pylon consist of a top member formed of a light-alloy channel between two extruded angles connected by a cover plate, and of a bottom member made from a light-alloy casting. The top and bottom members are connected at intervals by vertical angles, between which are attached steel bridge pieces. The whole is covered with a skin, forming a streamlined container which is bolted to the underside of the wing, and which houses the bomb release and fusing mechanisms, electric cables, etc., together with fuel pipes and valves necessary when a drop tank is fitted.

Aileron operating gear

9. The aileron hydrobooster and operating gear is housed between ribs R and S in a bay formed by these two ribs, a diaphragm and the rear spar. The gear consists of the booster jack, control tubes and levers, all of which are carried on two sets of bearing blocks attached to the outboard face of rib R. For further information on this installation reference should be made to Chapter 4 of this section.

Wing tip

10. The detachable wing tip consists of a light-alloy shell stiffened by a number of ribs and attached to the outer wing outer rib. A housing with a transparent window and containing the navigation lamp is incorporated at its leading edge. The pressure head, which is carried on a tube mounted to a rib extending diagonally from the forward end of rib R to rib S, projects forward from the leading edge of the port wing tip.

Flaps

11. The flaps are of conventional design, each consisting of a single spar with a number of ribs covered on the undersurface only with a light-alloy skin. A reinforcing plate is incorporated along the upper surface of the trailing edge. Each flap is hinged at four points (*para.* 5) and extends from the wing root to just inboard of the ailerons.

Ailerons

12. Each aileron consists of a main spar with a number of ribs and stiffeners covered with a light-alloy skin. They are hinged at three points, the centre hinge-point of each aileron having a double hinge (*para.* 5). The port aileron also incorporates a small electrically-operated trim tab in its inboard trailing edge. The ailerons are provided with power-operated controls, or hydroboosters, to facilitate operation at high speeds.

SERVICING

General

13. Little servicing is possible to the main plane apart from the servicing of the various systems which are described elsewhere in this volume. The servicing instructions given in this chapter will, therefore, only include the items not covered in the other chapters complementary to the main plane structure.

14. After servicing it is necessary to check that all access panels and doors are securely locked and are flush with the surrounding structure; this is very important as any alteration in contour will give rise to a shock-wave, resulting in a vast increase in drag and consequently a loss in performance.

Lubrication

15. The main lubrication points for the main plane are in the flying controls (*covered by Sect. 3, Chap. 4, fig. 1 and 2*). The remaining points are dealt with in this chapter and are given on fig. 16, 17 and 18 with a key to the lubricants on fig. 15.

REMOVAL AND ASSEMBLY

General

16. The separation of the outer wings from the stub wings and the removal of the various major components, together with the method of slinging during removal is shown in the illustrations contained in this chapter. In general, the assembly of the units is a reversal of the removal, but where there is any special assembly feature it is covered in the key to the illustration.

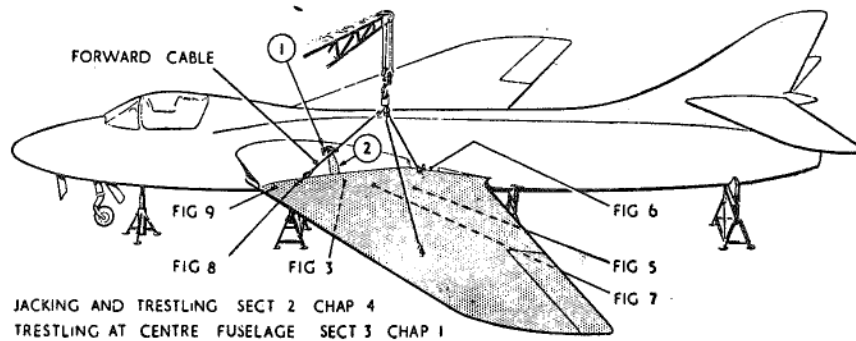

Fig. 2. Removing wing

REMOVAL OF WINGS (fig. 2—10)

Jack and trestle the aircraft (*Sect. 2, Chap. 4*) and place two additional trestles beneath the centre fuselage (*Sect. 3, Chap. 1*).

Render the aircraft electrically safe (*Sect. 5, Chap. 1*).

Dissipate the hydraulic fluid pressure (*Sect. 3, Chap. 6*).

Remove the access panels over front and rear spar joints (*fig. 2, items 1, 2 and 3* and the panels forward of front spar for refuelling pressure relief valve, item 4).

Remove the pressure head as described later in this chapter.

Drain the wing fuel tanks as described in *Sect. 2, Chap. 2*.

If fitted, remove the wing drop tanks or external stores from the pylons (*Sect. 2, Chap. 2*). Should it be required to remove the pylon, reference should be made to *fig. 20* of this chapter.

From inside the wheel well, disconnect all the services between the fuselage and the wing. For the port wing refer to *fig. 3*

and disconnect the aerial lead (1) and the electrical supply leads (2). Detach the wheel door lock controls from the lever (3). Disconnect the Teleflex control tube at (4) and at the connection to the swivel block on the bracket attached to the fuselage, leave loose. Unscrew the locknut and the Teleflex cable at the end connected to the link on the wheel door (*Sect. 3, Chap. 5, fig. 5*) and also at the leg fairing lock. Withdraw the cable at this lock, coil-up and attach securely to the wing structure.

Referring again to *fig. 3*, dismantle the clamps (5) and remove the short lengths of pipes by disconnecting the unions at both ends. Remove the fuel pipe (6) by disconnecting the unions at both ends of the pipe.

Remove the vent pipe (7) by disconnecting the clamp fitting similar to (9) at *fig. 4* of the tank connection and at the union forward of the front spar.

For the starboard wing (front spar) refer to *fig. 4*. Dismantle the clamp (1) and remove the short lengths of pipe by disconnecting the unions at both ends. Disconnect the electrical supply lead (2) and the compass

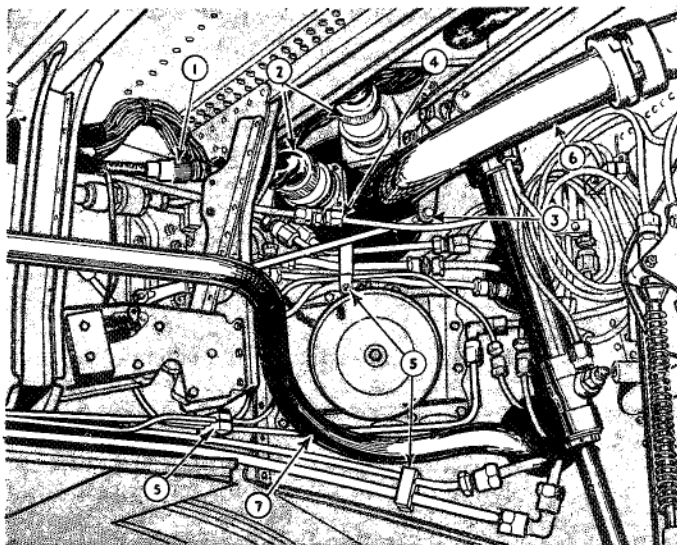

Fig. 3. Connections at front spar (port)

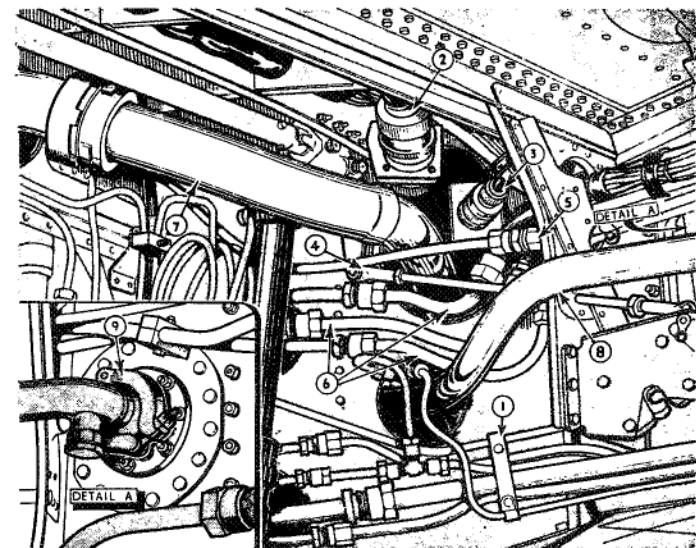

Fig. 4. Connections at front spar (starboard)

supply lead (3). Detach the wheel door lock controls from the lever (4). Disconnect the Teleflex control as described for fig. 3 (5). Remove the short lengths of pipe (6) and the fuel pipe (7) by disconnecting the unions at both ends of the pipes. Remove the vent pipe (8) by disconnecting the clamp fitting (9) detail A at the tank connection and at the union forward of the front spar.

Refer to fig. 5 for either port or starboard wing. Disconnect the pipes (1) and the lever (2).

Note . . .

There are three hydraulic pipes at this point for the port wing and five for the starboard wing.

Disconnect and stow away the electrical supply cable A.4 (4), the plug and socket is located between the drag members on the side of the fuselage.

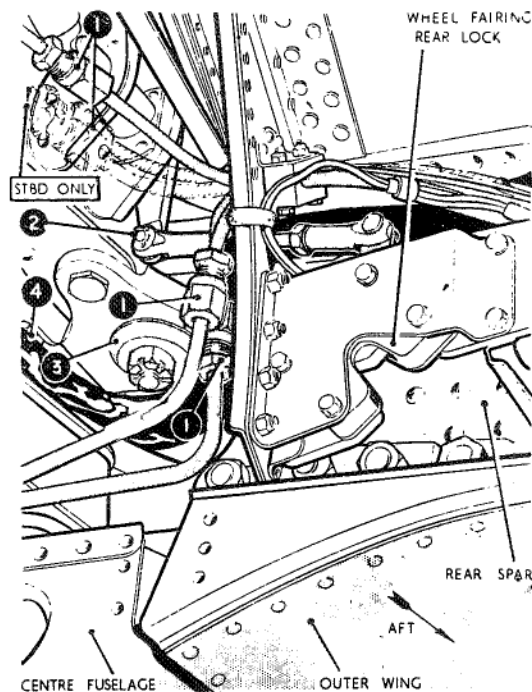

Fig. 5. Connections at rear spar (port)

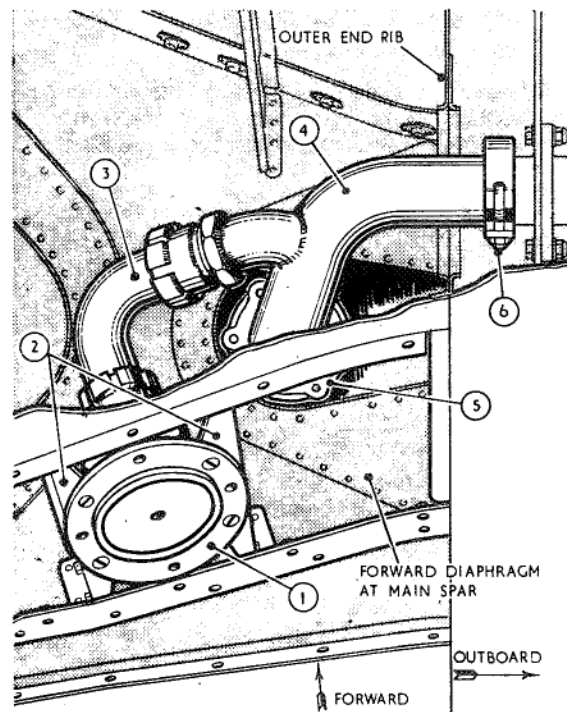

Fig. 6. Fuel pipe connections forward of front spar

Through the access hole port and starboard in the bottom surface of the stub wing forward of the front spar, first remove the pressure relief valve fig. 6 (1) by taking out the four screws securing the valve to the mounting brackets and disconnecting the outer sleeve on the pipe (3).

Detach the mounting brackets (2) and remove the pipe (3).

Unscrew the six bolts at (5) and the clamp fixing at (6) and then remove the pipe (4), taking care not to lose the rubber sealing rings at each joint.

Disconnect the aileron control rod (fig. 7) by removing the pivot bolt. While at this access hole disconnect the two pipes which run rearwards. The two pipes running forward should not be disturbed.

Blank off all exposed pipe connections.

Remove the small access panel over the wheel axle in the leg fairing and remove the undercarriage wheel (A.P.2337, Vol. 1, Sect. 1, Chap. 1, App. 54).

Procure an undercarriage up-lock tool (Stores Ref. 26 FX/95080), refer to fig. 8 and proceed as follows:—

Insert the hook portion of the tool over the spigot mounting as shown and allow the screwed rod portion to hang down minus its retaining plate, washer and nut. Connect a hydraulic ground rig direct to the main undercarriage jack via the pipes which have been disconnected from the stub wing.

Partially retract the leg until the axle is approaching the end of the screwed rod. Ensure that this is lined up with the hole through the axle and continue the leg retraction so that the screwed rod passes through the hole in the centre of the axle. Secure the undercarriage leg in the retracted position by assembling the retaining plate, axle nut, and shaped washer and screwing up nut "A".

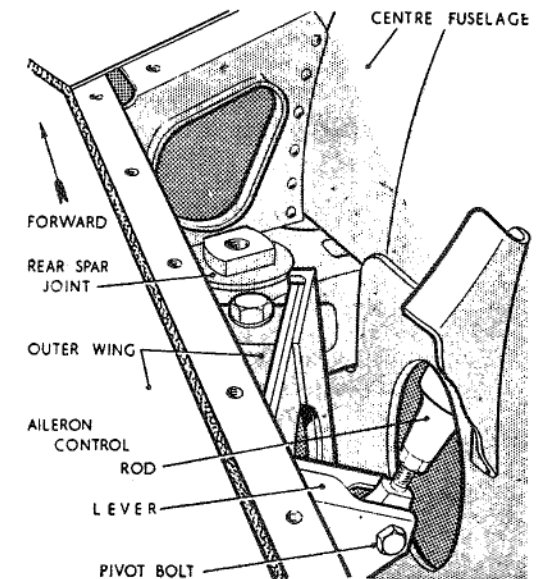

Fig. 7. Details at rear spar joint

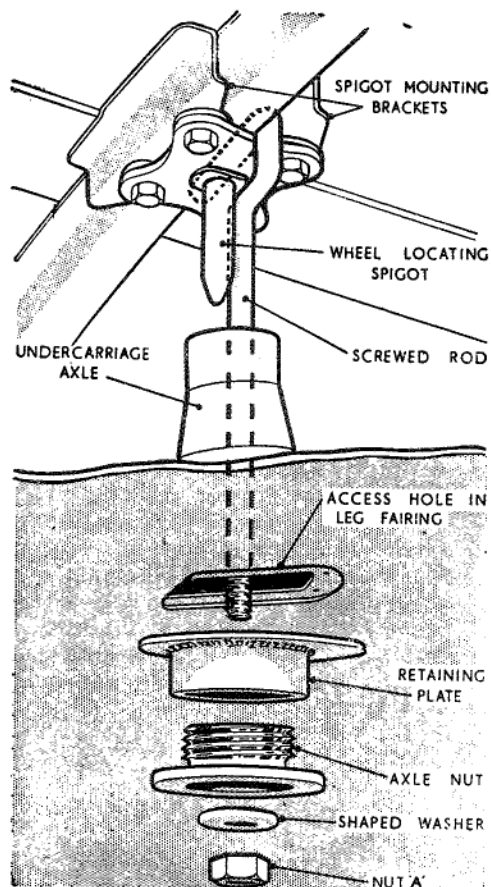

Fig. 8. Undercarriage up-lock tool

Disconnect the ground rig.

Remove the sealing plugs from the lifting sockets in the upper surface of the wing. Detach the eye bolts from the sling, screw them into the wing lifting sockets and assemble the sling (fig. 9). Ensure that the sling cables marked FORWARD fit into the eye bolts of the front spar. Remove the access panel shown in fig. 10 and withdraw the pin from the socket and spigot.

Take the weight of the wing from the trestles via the sling, ensuring that the opposite wing not yet removed is correctly supported by its trestles.

Remove the split pins, slotted nuts and cup washers (3) (fig. 5) at the rear spar joints and withdraw the pins, using extractors Stores Ref. 26FX/95059.

Remove the split pins, slotted nuts and cup washers from the front spar joints and withdraw the pins, using extractor Stores Ref. 26FX/95058.

Remove the split taper bushes from the front spar joints with bush extractor Stores Ref. 26FX/95040, and from the rear spar joints with bush extractor Stores Ref. 26FX/95041.

The wing may now be removed by the sling and placed on cradles Stores Ref. 26FX/95022 and 26FX/95023, which are supported by U.J.T.6.

To prevent damage and injury to personnel, while the wing is being slung after removal from the fuselage, it is recommended that

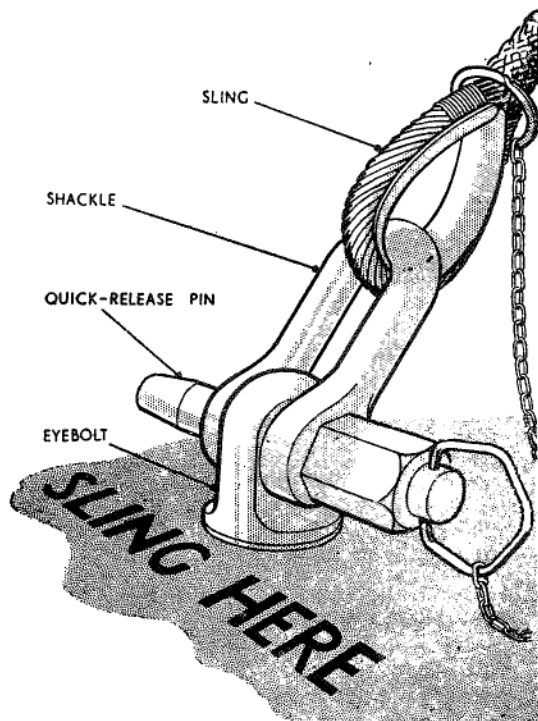

Fig. 9. Sling attachment

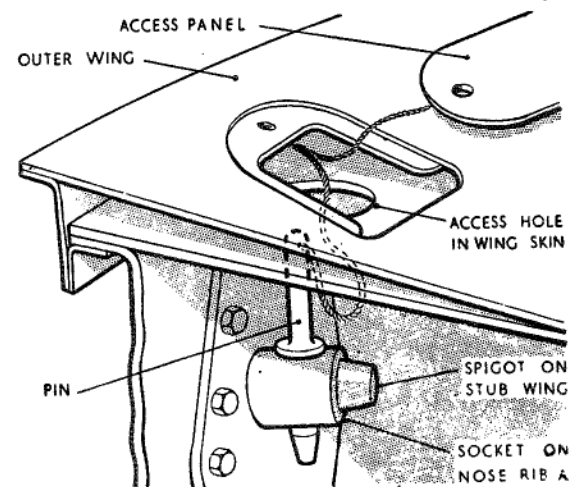

Fig. 10. Locating spigot and socket

the small trailing-edge fillet is removed by unscrewing the six countersunk screws and the two bolts securing it to the wing structure.

WING ASSEMBLY

When assembling a wing it is necessary to carry out the following operations:—

- (1) After the wings have been joined to the fuselage by the wing pins, support the undercarriage, remove the up-lock tool, release the leg fairing locks by pulling the Teleflex control at the wing root and lower gently.
- (2) Adjust the undercarriage and fairings in accordance with Sect. 3, Chap. 5, and the flying controls in accordance with Sect. 3, Chap. 4.
- (3) Fill and bleed the undercarriage hydraulic circuit in accordance with Sect. 3, Chap. 6.
- (4) Test the fuel system in the wings in accordance with Sect. 4, Chap. 2.

Note . . .

Existing split bushes and wing pins may be fitted to the front and rear spar joints, if serviceable.

RESTRICTED

May, 1959

AIR MINISTRY

Air Publication 4347D

Volume 1

HUNTER F Mk. 4 AIRCRAFT

ADVANCE INFORMATION LEAFLET NO. 2/59

Insert this leaflet to face Vol.1, Sect.3, Chap.2, Fig. 9 and 10

ASSEMBLY OF WINGS

When reassembling the wings to the aircraft, the pins and bushes securing the wings (port and starboard) at the front and rear spar pin joints, together with the joint faces, must be lubricated with oil OX-14.

Note (1) The information contained in this leaflet will be incorporated by normal amendment action in due course.

(2) If, after the receipt of this leaflet, an amendment list with a prior date and conflicting information is received, the information in the leaflet is to take precedence.

RESTRICTED

REMOVAL OF AILERON (fig. 11—14)

Note . . .

*Operations marked * apply to the removal of the PORT aileron only.*

Remove the fairing between the inboard end of the aileron and tail rib M1 (fig. 11) by unscrewing and removing the twelve countersunk screws.

* Lower the flaps to expose the access door in the port flap roof, between tail ribs L and M. Render the aircraft electrically safe (Sect. 5, Chap. 1). Remove the access door and release T.B.27 from its mounting and draw it and its cables through the access hole, remove the cables from the actuator and the transmitter from the terminal block. Temporarily put back the terminal block on its mounting and refit the access door. Close the flaps with an electrical supply from the ground trolley.

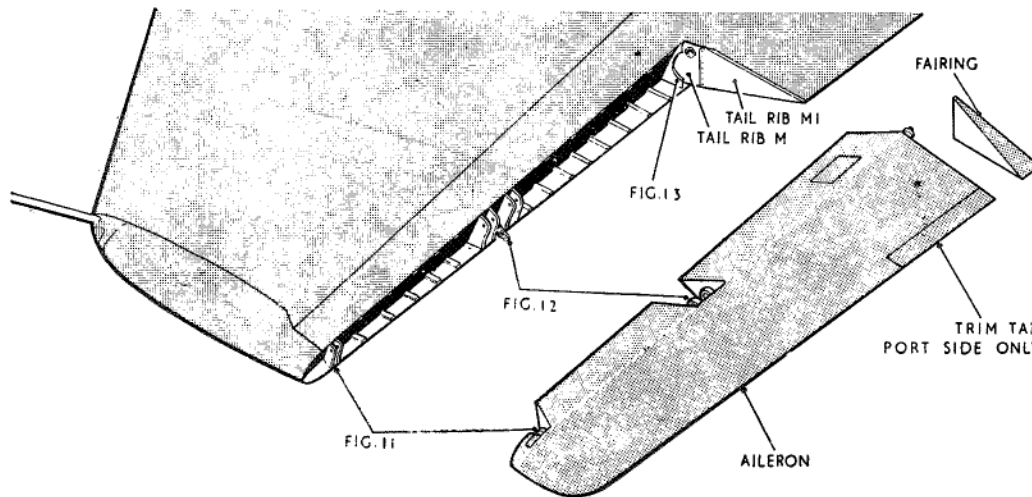

Fig. 11. Removing aileron

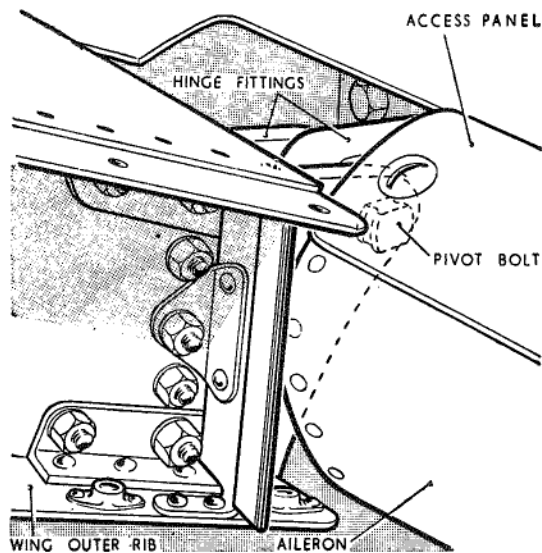

Fig. 12. Outer hinge

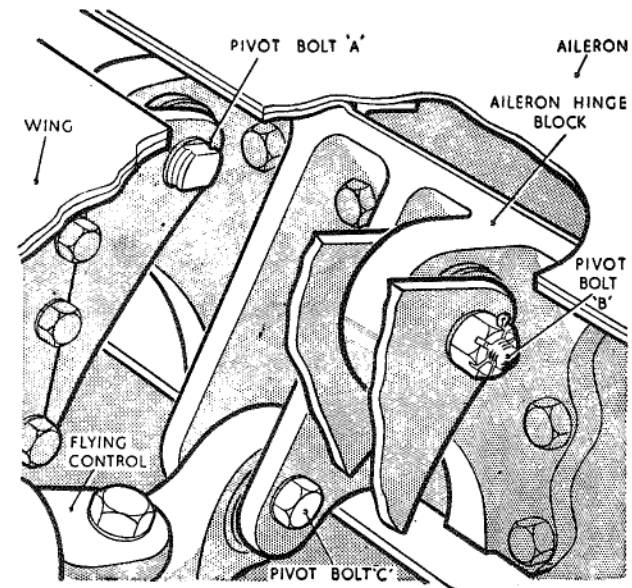

Fig. 13. Centre hinge

Support the aileron in the neutral position and remove the split pin, slotted nut and washer from the pivot bolt "C" (fig. 12), connecting the flying controls to the aileron hinge block, and remove the pivot bolt. From the aileron hinge block remove the split pins, slotted nuts and washers and withdraw the pivot bolts A and B from the two centre hinges.

Lower the aileron as far as it will go and support it while in this position, thus exposing the access panel (fig. 12) in the top surface of the aileron, adjacent to and outboard of the outer hinge. Remove the panel after taking out the two screws. Remove the split pin, slotted nut and washer from the pivot bolt and withdraw it from the outer hinge fittings and out through the access hole.

The aileron may now be removed by raising it to the neutral position, swinging the outboard end rearwards sufficiently to separate the centre and outer hinge fittings and by lifting the outboard end. The inner hinge (fig. 14) will pivot with the spherical

bush in the bearing bracket on tail rib M. When the hinges fittings have cleared one another, ease the inner hinge out of the spherical bush.

* Before finally removing the port aileron pull the electrical supply leads, from the actuator and transmitter, through the duct on tail rib M.

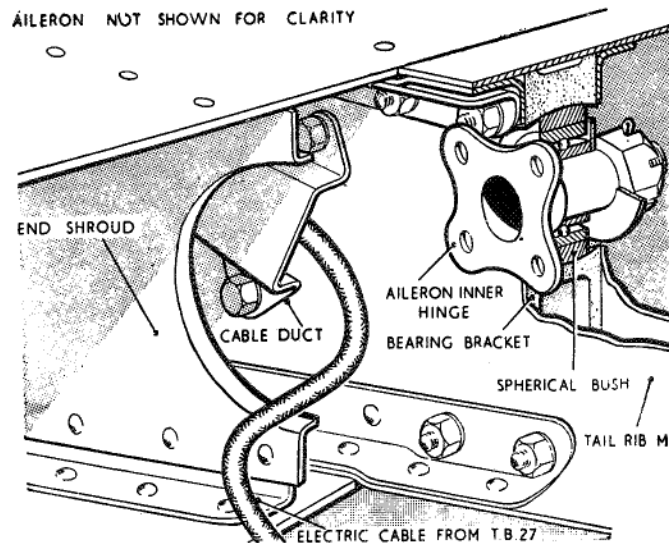

Fig. 14. Inner hinge

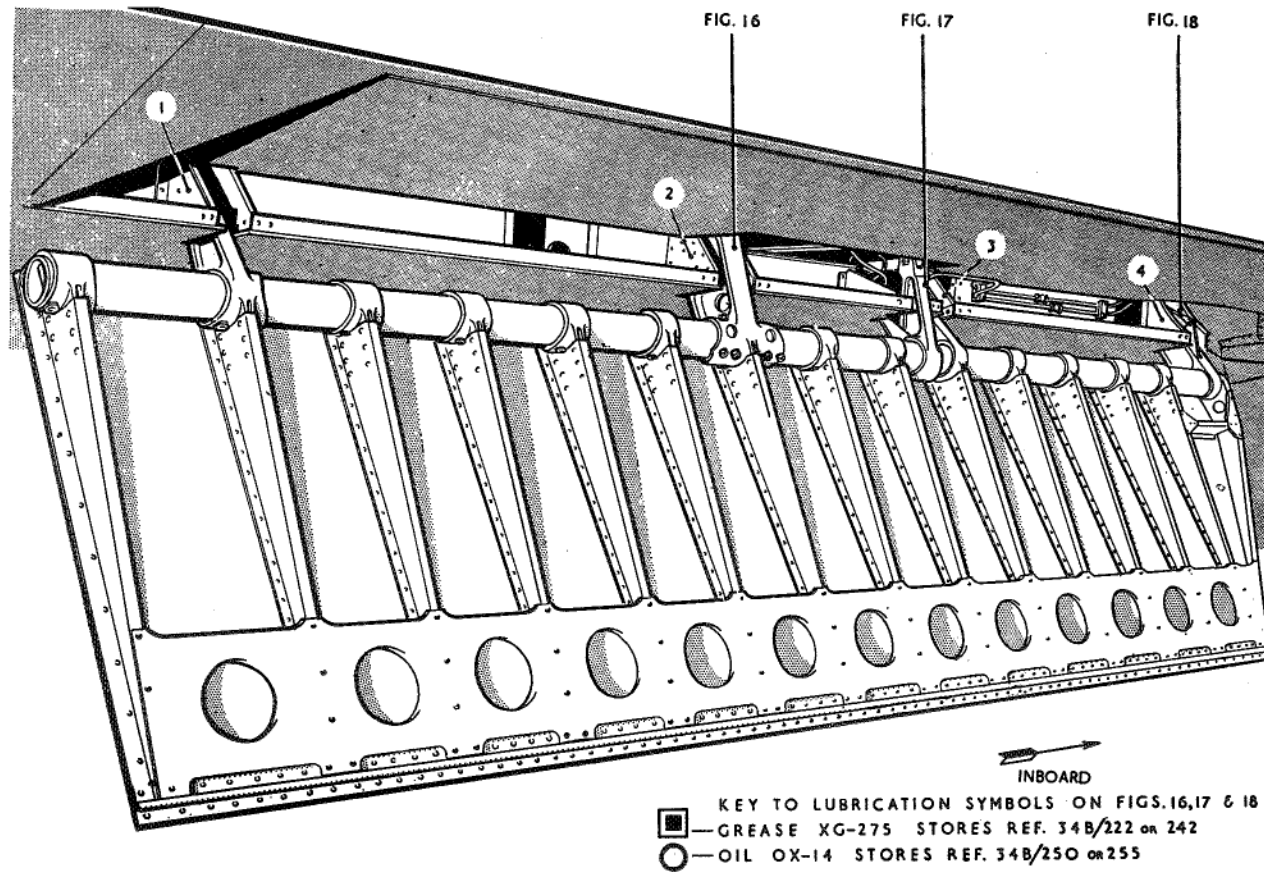

Fig. 15. Removing flaps

(See text overleaf)

REMOVAL OF FLAPS (fig. 15-18)

Note . . .

Removal of the port flap is dealt with in this text. The removal sequence of the starboard flap is similar but of opposite hand.

Lower the flaps to the maximum extended position (Sect. 3, Chap. 4).

Render the aircraft electrically safe (Sect. 5, Chap. 1).

Support the flap and remove the split pin, slotted nut, washer and bolt connecting the operating jack to the flap spar lever (fig. 16) and similarly at the synchronizing jack (fig. 17).

At the inboard end of the port flap spar remove the split pin, washer and pivot pin from the control rod and lever (fig. 18).

Remove the split pins, slotted nuts, washers and pivot bolts from the four bearing

brackets (fig. 15 (1), (2), (3) and (4)) and the flap bearings.

The flap may now be removed.

ASSEMBLY

It is important to ensure that the pivot bolt sleeves are assembled the correct way round, i.e. the end having the large chamfer must be towards the lubricator nipple and so forming a lead for the entry of the pivot bolt.

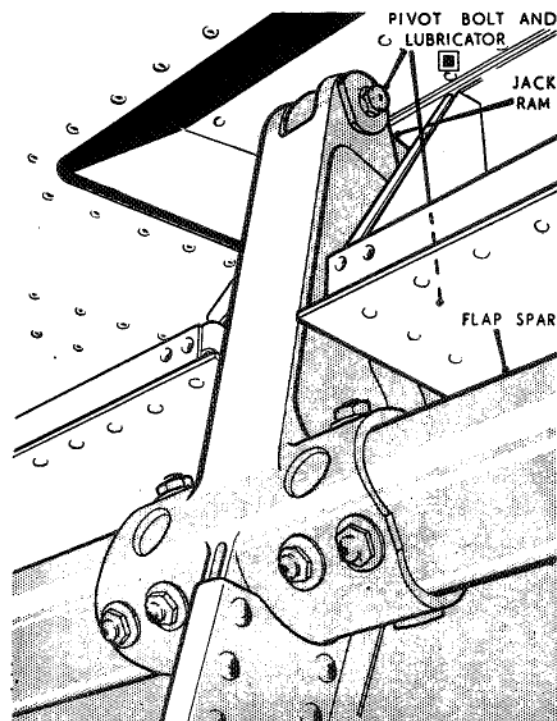

Fig. 16. Operating jack attachment

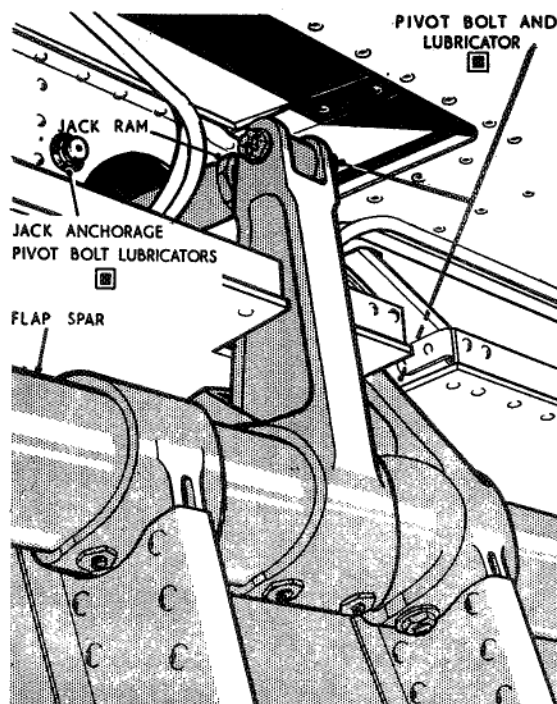

Fig. 17. Synchronizing jack attachment

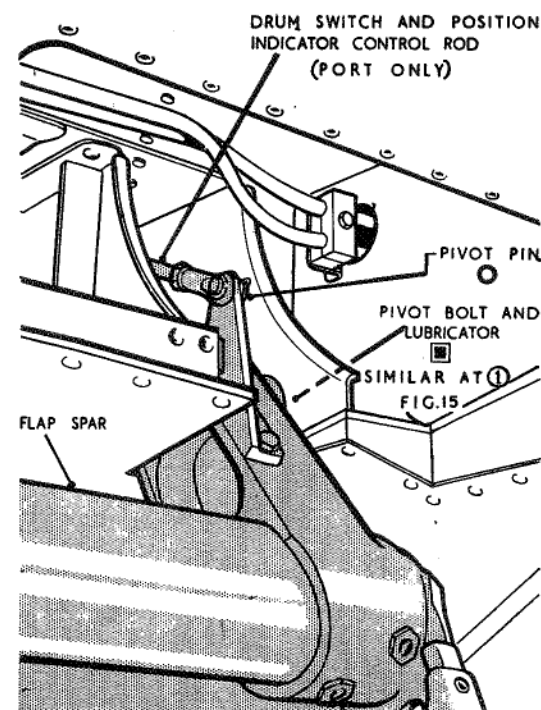

Fig. 18. Drum switch, etc., control rod attachment

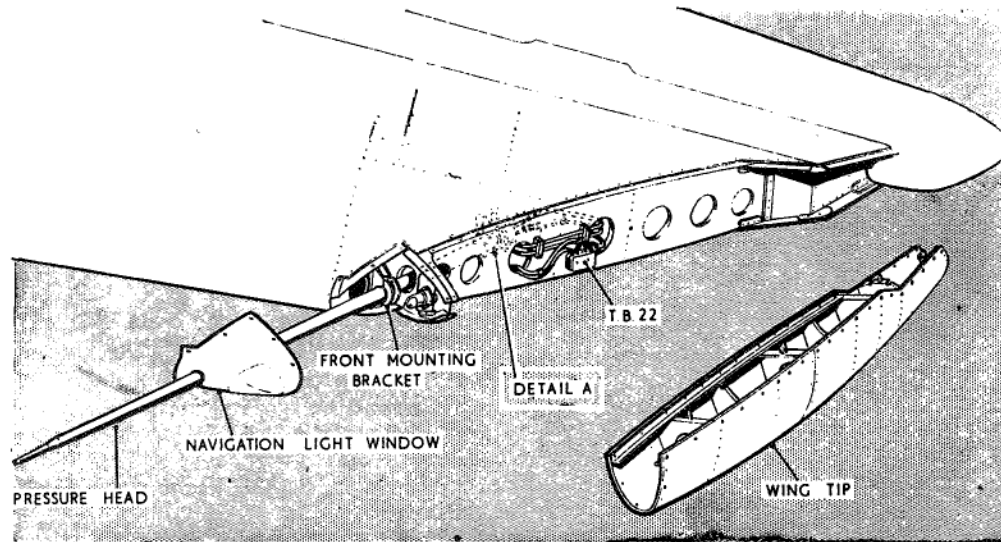
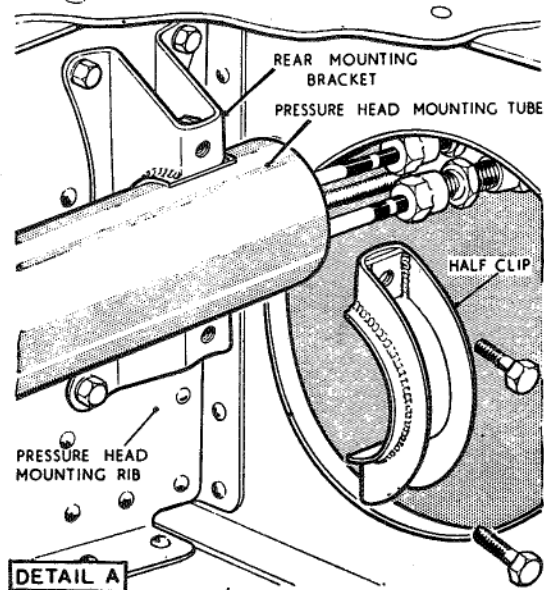

Fig. 19. Removing wing tip and pressure head



REMOVING WING TIP AND PRESSURE HEAD (fig. 19)

Unscrew and remove the ten countersunk screws from the navigation light window and remove by sliding it along and off the pressure head.

Support the wing tip and detach it by removing the forty-four countersunk screws and withdraw the wing tip spigots out of the wing outer rib.

Render the aircraft electrically safe (Sect. 5, Chap. 1). Disconnect at T.B.22 the electric supply leads from the pressure head, taking care not to disturb the leads from the navigation light at the same terminal block.

Disconnect the static and pressure pipes at the rear end of the pressure head, the unions being reached through the lightening holes in the wing outer rib (detail "A").

Remove the two half clips from the mounting brackets on the pressure head mounting rib. Access to the rear clip (detail "A") being gained through the lightening hole in the wing outer rib.

Withdraw the pressure head out of the wing structure, complete with the pipes and electric supply lead.

Note . . .

On re-assembly check that the rubber seal on the port navigation light window is securely fixed to the fairing.

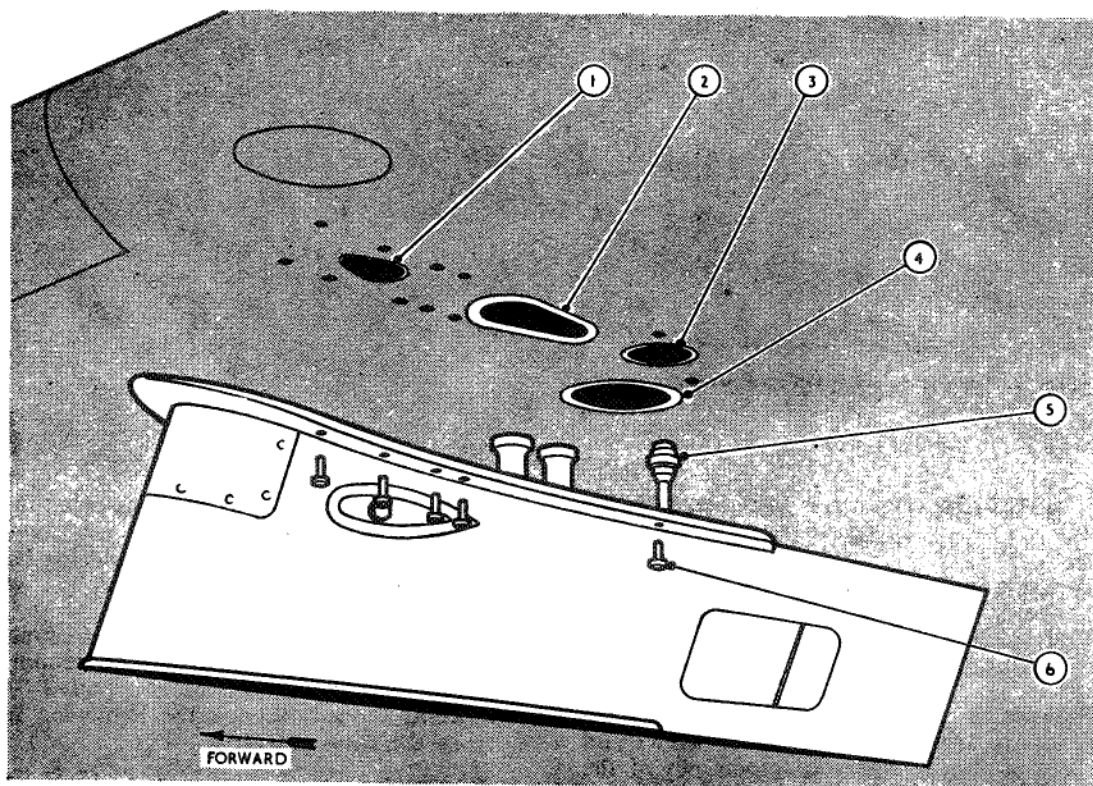

Fig. 20. Removing universal pylon

REMOVING UNIVERSAL PYLON (fig. 20)

Remove access panel (4) and through this disconnect the electrical plug and socket (5).

Remove the eleven fixing bolts (6). The pylon is now free from the wing.

After removing the pylon, the holes in the wing should be covered with their respective cover plates. At (1) fit inner cover A.198509 and outer cover A.198510. At (2) cover plate B.199581 port and B.199582 starboard.

At (3) fit inner cover A.198511 and outer cover F.198512.

RESTRICTED



This file was downloaded
from the RTFM Library.

Link: www.scottbouch.com/rtfm

Please see site for usage terms,
and more aircraft documents.