

GROUP C2

FIRE WARNING AND EXTINGUISHER (CODE FW AND FE)

LIST OF CONTENTS

	Para.
<i>Introduction</i>	1
DESCRIPTION	
<i>Fire warning and extinguisher</i>	2
<i>Operation</i>	3
SERVICING	
<i>General</i>	5
<i>Testing fire warning lamp</i>	6
<i>Testing fire extinguisher</i>	7
<i>Testing flame switches</i>	8
<i>Re-setting inertia switches</i>	9
REMOVAL AND ASSEMBLY	10
ILLUSTRATION	
<i>Fire warning and extinguisher</i>	Fig. 1

Introduction

1. This group contains a brief description, including the method of operation, of the fire warning and extinguisher circuit installed in this aircraft, together with the necessary servicing information required to maintain the equipment in an efficient condition. A routing and theoretical diagram of the circuit is also included. For a description of the electrical system of the aircraft as a whole, including system wiring details, referencing of components and general servicing, together with the location and removal of the major components, reference should be made to Groups A1, A2 and A3 of this chapter. Detailed information on the standard components used will be found in the appropriate volumes of A.P.4343 series.

DESCRIPTION**FIRE WARNING AND EXTINGUISHER**

2. A warning lamp, provided to indicate fire in the engine bay, is contained in a combined fire warning lamp and extinguisher switch, situated on the starboard arch panel in the cockpit. The lamp is controlled by a number of automatic re-setting Mk. 4, No. HS/RS.300 flame switches, which are situated around the engine bay between the rear spar frame and rear transport joint and at frame 45. The warning lamp may be tested by pulling out the extinguisher switch button. The Mk. 13A fire extinguisher is carried in a cradle mounted on the aft face of the main spar in the centre fuselage and feeds the engine spray units, via the inlet

connection on the engine. The extinguisher is discharged manually by depression of the button of the combined fire warning and extinguisher switch, or automatically, in the event of a crash landing, etc., by operation of relay X, situated on the supply panel, which is energized by two Mk. 1 Type S3 inertia switches mounted one underneath the battery platform in the radio bay and the other on frame 12 in the gun bay. At the same time, this relay isolates the batteries from all but the essential load line and also open-circuits the generator fields (*Group B1, para. 9*). For a full description of the fire protection system, as a whole, reference should be made to Sect. 4, Chap. 5 of this volume.

Operation

3. The flame switches are all connected in parallel, and, consequently, operation of any one switch will complete the circuit from the fuse to the fire warning lamp, via contacts 6 and 7 of the combined fire warning and extinguisher switch unit and thereby light the lamp. The flame switch contacts close at

300 deg. \pm $\begin{matrix} 30 \\ 0 \end{matrix}$ deg. C., and the lamp may light

intermittently on the ground, or in the air, due to heat surges in the engine bay. It must be noted that the flame switches do not discharge the fire extinguisher, which, if the lamp remains alight steadily for a period of 5 to 10 seconds, must be manually discharged by depression of the extinguisher push-switch, thus making contacts 1 and 5 to complete the circuit to the discharge head fuse. To test the lamp filament for correct functioning, the fire extinguisher push-switch is pulled, thus making contact 3, which supplies the lamp directly from the fuse, thereby lighting the lamp without the flame switches having been operated.

4. In the event of a crash landing, the inertia switches, which are connected in series, will operate and complete the circuit from the essential load to relay X, which will be energized and make contacts 1 and 3 and break contacts 2. Contacts 1 complete the circuit from the essential load line to the extinguisher discharge head fuse, thus discharging the extinguisher; contacts 3 feed the generator crash relays, which, when energized, open-circuit the generator fields (Group B1, para. 9). When contacts 2 break, the battery master switch and the battery relay are both de-energized and isolate the batteries from all but the essential load line.

SERVICING

GENERAL

5. For general servicing of the electrical system as a whole, reference should be made to Group A1 of this chapter. All the components should be kept clean and inspected

periodically for signs of damage and to ensure that they are securely mounted. Apart from the servicing described in the following paragraphs, together with the standard bench testing of the components, as described in the appropriate Air Publications, no further servicing should be necessary.

Warning—As operation of the battery master switch will not isolate the fire extinguisher circuit, the system must be rendered safe by removing the circuit fuses before commencing any servicing operations found necessary after carrying out the following tests.

TESTING FIRE WARNING LAMP

6. The fire warning lamp, contained in the combined fire warning and extinguisher switch unit, should be tested for correct operation, before each flight, by pulling out the fire extinguisher switch button. When the switch is pulled, the lamp should light to indicate that the bulb is serviceable.

TESTING FIRE EXTINGUISHER

7. To test the continuity of the fuse in the fire extinguisher discharge head, remove the electrical socket from the plug on the extinguisher and connect a suitable safety ohmmeter to the plug. If the reading does not lie between 7 and 11 ohms, the extinguisher must be removed from the aircraft and replaced with a fully serviceable component. It must be noted that the safe test current is 8-12 mA. To measure the insulation resistance of the extinguisher, short together the pins of the plug on the discharge head, then, using an insulation resistance tester, Type C, take a reading between the shorted pins and the extinguisher body.

Note . . .

The actuating fuses in the extinguisher discharge head are very sensitive and the electrical checks should, therefore, be made with care. In the interest of safety, the junction box should always be attached to

the discharge head during tests as the charge plug emerges with considerable force on firing. If the extinguisher is accidentally discharged DO NOT INHALE THE GAS.

TESTING FLAME SWITCHES

8. The re-setting flame switches, which operate the fire warning lamp, may be tested in situ by using a 24-volt, 6-amp. battery-operated, Type 1 tong tester. After allowing 6 minutes for the tester to warm up, it should be fitted over the barrel of each switch in turn, when the warning lamp should light to indicate satisfactory operation. The temperature setting adjuster is locked and sealed during manufacture, and in no circumstances must any attempt be made to interfere with its setting. An inspection should, however, be made to ensure that the expansion barrel of each flame switch is not damaged.

RE-SETTING INERTIA SWITCHES

9. To re-set each inertia switch, proceed as follows:—

- ◀ (1) Disconnect the battery. ▶
- (2) Remove the radio access door.
- (3) Remove the terminal cover from the inertia switch mounted on the battery platform.
- (4) Re-set the switch by depressing the re-setting plunger situated between the terminals of the switch.
- (5) Replace the terminal cover and radio access door.

REMOVAL AND ASSEMBLY

10. Once access has been obtained, the removal and assembly of the electrical equipment forming the fire warning and extinguisher circuit should present no unusual difficulties. The location of, and access to, all the components is indicated in Group A3 of this chapter, while the removal of the fire extinguisher is fully described in Sect. 4, Chap. 5 of this volume.

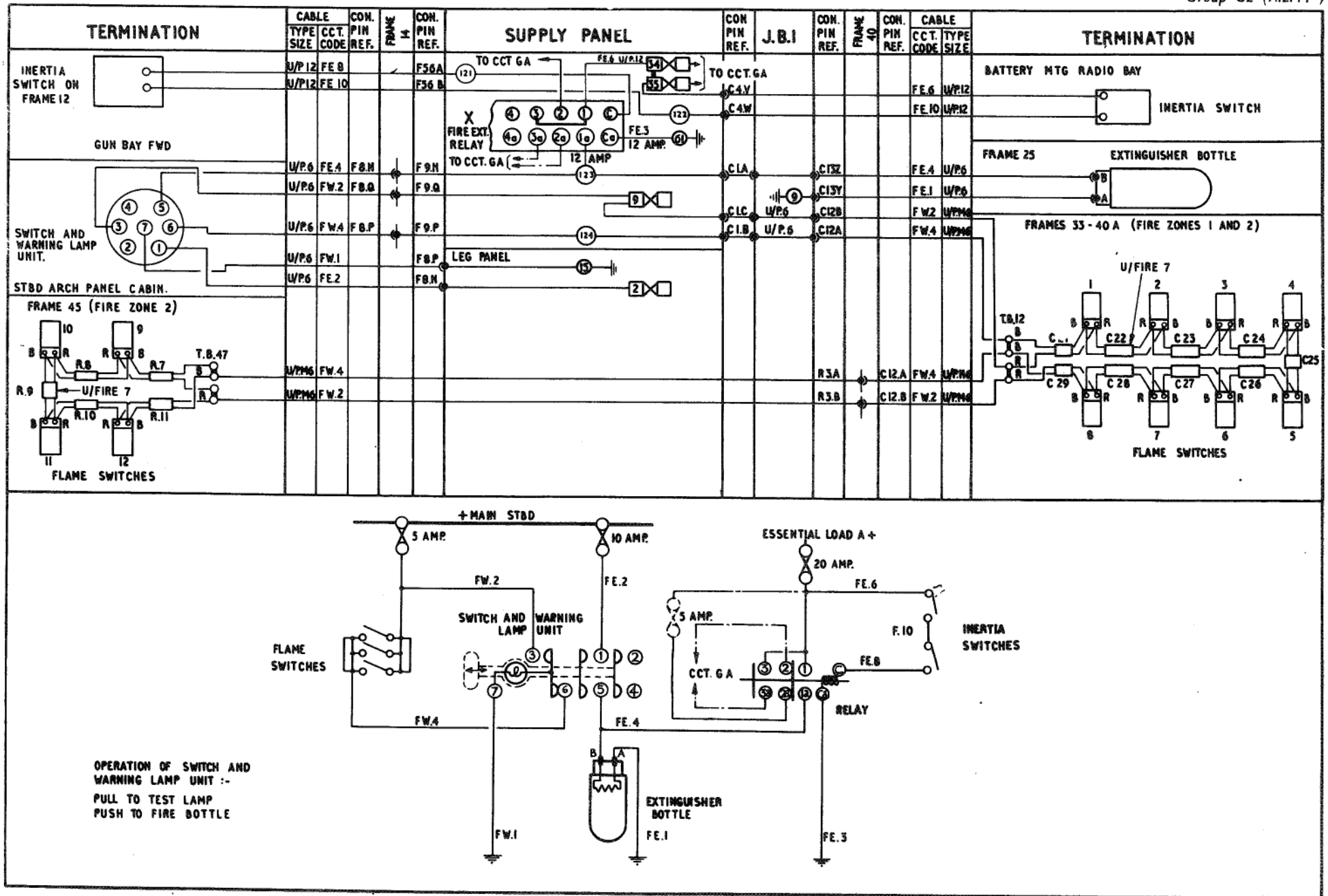

FIG. 1. FIRE WARNING AND EXTINGUISHER
RESTRICTED



This file was downloaded
from the RTFM Library.

Link: www.scottbouch.com/rtfm

Please see site for usage terms,
and more aircraft documents.

R-Type Mk2
pressure breathing
mask

R-Type mask
used on Dominie
by RAF until 2011
© Copyright 2011 Scott Bouch