

## GROUP D3

## TAIL PLANE CONTROL AND POSITION INDICATOR (CODE T AND TD)

## LIST OF CONTENTS

	<i>Para.</i>
<i>Introduction</i> ... ..	1
<b>DESCRIPTION</b>	
<i>Tail plane control</i> ... ..	2
<i>Operation</i> ... ..	3
<i>Tail plane position indicator</i> ... ..	6
<i>Operation</i> ... ..	7
<b>SERVICING</b>	
<i>General</i> ... ..	8
<i>Tail plane actuator</i> ... ..	9
<i>Tail plane position indicator and transmitter</i> ... ..	10
<b>REMOVAL AND ASSEMBLY</b> ... ..	11

## ILLUSTRATION

	<i>Fig.</i>
<i>Tail plane control and position indicator</i> ... ..	1

**Introduction**

1. A brief description of the tail plane control and position indicator circuits installed in this aircraft, including the method of operation and the necessary servicing information required to maintain the equipment in an efficient condition, is contained in this group, together with a routing and theoretical diagram of the circuits. For a description of the electrical system of the aircraft as a whole, including system wiring details, referencing of components and general servicing, together with the location and removal of the major equipment, reference should be made to Group A1, A2 and A3 of this chapter. Detailed information on the standard components used will be found in the appropriate volumes of A.P.4343 series.

**DESCRIPTION****TAIL PLANE CONTROL**

2. The incidence of the tail plane is varied in flight by the action of a Type A1603 linear actuator located in the dorsal fin below the tail plane between frames 51 and 52. The actuator, which incorporates internal limit switches to control its range of movement, is provided with a stand-by motor to maintain operation should the main motor or its electrical control circuit fail. The main motor is controlled by a thumb switch on the control column via a Type D.8710 reversing contactor, which is situated in the dorsal fin just forward of the actuator. The stand-by motor is controlled by a separate

circuit, including its own Type D.8710 reversing contactor, mounted with that for the main motor, which is energized by a switch located under a guard cover on the forward portion of the cockpit port shelf. Raising the guard cover, to enable the switch to be used, operates an interference micro switch, which automatically isolates the main control column switch circuit. The incidence of the tail plane is shown on an indicator located on the centre instrument panel (*para. 6*).

**Operation**

3. The action of the control circuit for the tail plane actuator's main motor is such that, when the thumb rocker of the control column

switch is pressed downwards, current is conducted from the control circuit fuse, through the contacts of the interference micro switch, which are made when the guard cover is locking the stand-by control switch, to the control column switch, and through this switch to pin B of the main motor limit switches. From pin B the current passes through the main motor limit switches, which are made until the actuator is fully retracted, to pin A of the motor limit switches. Pin A is in contact with one of the coils of the reversing contactor controlling the main motor, and the negative return of this coil is taken to earth. When the coil is energized, contacts 1 and 2 of the contactor are made and complete the circuit from the circuit breaker to pin 3 of the main motor. Pin 3 feeds the retracting field windings of the motor and the negative return is conducted to earth via pin 1 of the main motor. The motor will thus rotate in such a direction as to retract the actuator ram and decrease the tail plane incidence, until switched off either by allowing the control column switch to return to the central position or by the operation of the limit switches when the actuator reaches the limit of its travel. When the control switch returns to the central position, the coil of the reversing contactor is de-energized, thus opening contacts 1 and 2 to break the main positive supply to the field windings. Operation of the limit switches de-energizes the reversing contactor in a manner similar to the action of the control switch.

4. When the thumb rocker of the control column switch is pressed upwards, current is conducted through the control switch to pin D of the main motor limit switches and energizes the other coil of the reversing contactor via the limit switches and pin C of the motor limit switches. The main positive supply from the circuit breaker will now be conducted through contacts 3 and 4 of the contactor and feed the "extend" field windings of the main motor. The negative return to earth is via pin 1 as before. The motor will thus rotate in the reverse direction and

extend the actuator ram to increase the tail plane incidence, until switched off either by the control switch or the limit switches in a similar manner to that described in para. 3.

5. The stand-by control switch located on the forward portion of the cockpit port shelf controls the actuator's stand-by motor via its reversing contactor in a similar manner to the control column switch as described in para. 3 and 4. When the guard cover locking the switch is lifted, it depresses the plunger of the interference micro switch, which opens the circuit to the control switch to isolate this control system from the main motor, thus preventing any fault in the circuit from affecting the operation of the stand-by control.

#### TAIL PLANE POSITION INDICATOR

6. The incidence of the tail plane is shown on a Type 472FL Desynn indicator located on the port side of the centre instrument panel. This indicator is operated by a Type D Desynn transmitter situated just above the actuator in the dorsal fin structure and linked to the actuator ram by a short operating rod.

#### Operation

7. For a full description of the Desynn system, together with the principle of operation, reference should be made to A.P.1275A, Vol. 1.

### SERVICING

#### GENERAL

8. For general servicing of the electrical system as a whole, reference should be made to Group A1 of this chapter. All the components should be kept clean and inspected periodically for signs of damage and to ensure that they are securely mounted. Apart from the servicing described in the following paragraphs, together with the standard routine bench testing of the components, as described in the appropriate Air Publications, no further servicing should be necessary.

#### TAIL PLANE ACTUATOR

9. This actuator is manufactured to give the required range of travel, and as internal limit switches are incorporated no further adjustment may be made, but the function of the unit should be checked over its full range to ensure that correct travel, as quoted in Sect. 3, Chap. 4, is obtained. This check should be made by using both the main and stand-by control circuits in turn. If a fault is reported in either the main or stand-by control circuits, the cause must be investigated and rectified before the next flight. Should a fault be found in the actuator, the unit must be removed and replaced with a fully serviceable component, as no attempt must be made to service the actuator in situ.

#### Note . . .

*The actuator must not be bench tested unless a complete control circuit, such as that in the aircraft, is available, as serious damage can result from incorrect or incomplete connections.*

#### TAIL PLANE POSITION INDICATOR AND TRANSMITTER

10. The standard routine serviceability tests, which should be applied to the Desynn indicator and its transmitter, will be found in the appropriate chapters of A.P.1275A, Vol. 1, while the method of adjusting the linkage between the transmitter and the actuator ram is contained in Sect. 3, Chap. 4.

#### REMOVAL AND ASSEMBLY

11. Once access has been obtained, the removal and assembly of the electrical components forming the tail plane control and position indicator circuits should present no unusual difficulties. The removal of the forward portion of the cockpit port shelf, which carries the stand-by control switch and the interference micro switch, is fully described in Group A2 of this chapter, while the location and access to all the components is indicated in Group A3 also of this chapter.

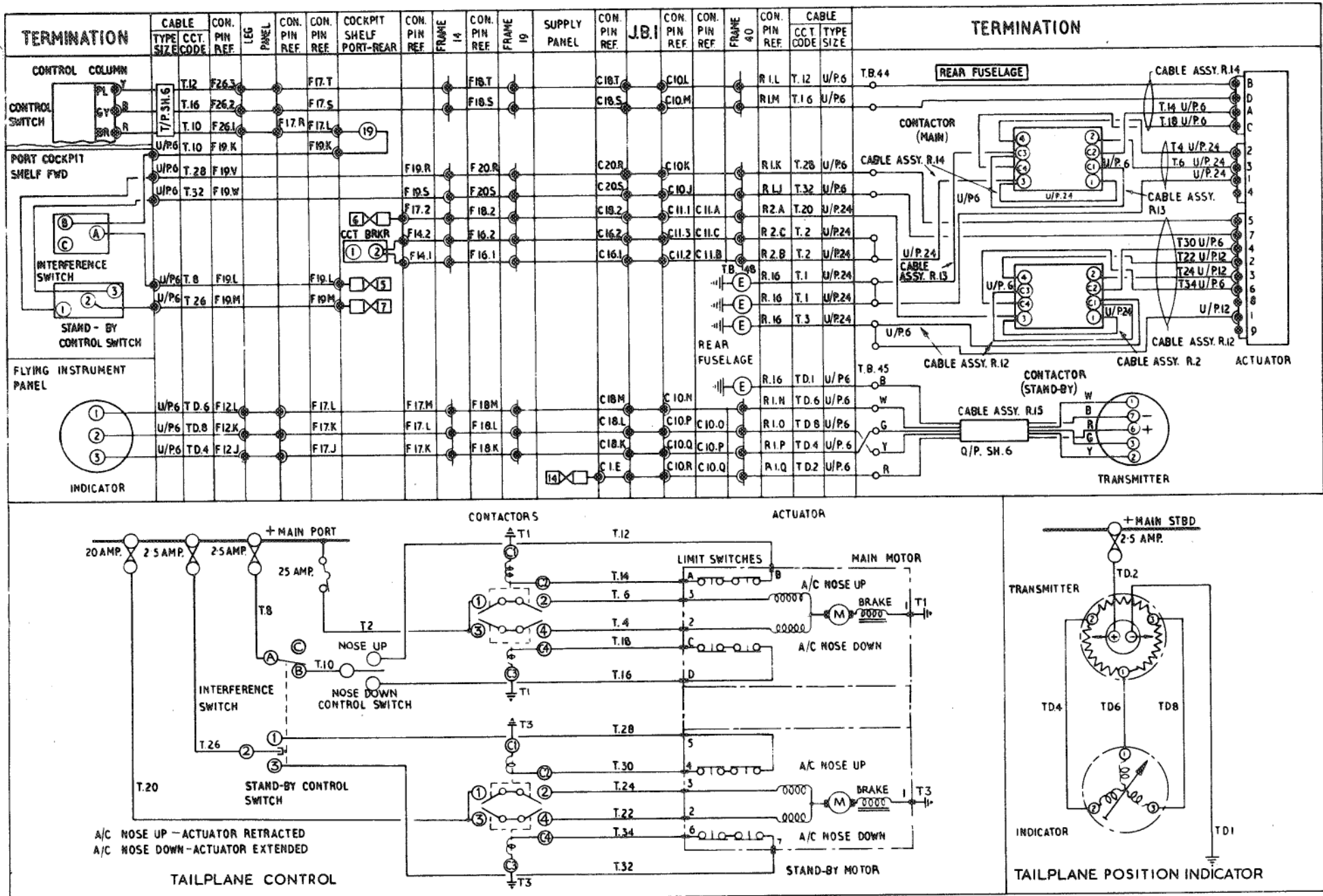

FIG. 1. TAIL PLANE CONTROL AND POSITION INDICATOR

RESTRICTED

This file was downloaded  
from the RTFM Library.  
Link: [www.scottbouch.com/rtfm](http://www.scottbouch.com/rtfm)

Please see site for usage terms,  
and more aircraft documents.

