

Group 2 ENGINE INSTRUMENTS

LIST OF CONTENTS

DESCRIPTION		Para.	SERVICING		Para.			Para.
Introduction	...	1	General	...	14	Errors of the fuel gauge in normal flight	...	26
Fuel contents gauges and fuel pressure warning (Code FG and FP)	...	2	Fuel contents gauges	...		Setting-up fuel contents gauges	...	27
Operation	...	3	Data and tolerances on units	...	15	Checking the fuel gauge installation	...	28
Oil pressure indicator (Code OP)	...	6	Tank units	...	16	Functional check	...	30
Tachometer	...	7	Tank terminals	...	17	Insulation resistance check	...	35
Tachometer (Code RA)	...	8	Complete tank with tank terminal	...	18	Fault location checks	...	36
Operation	...	9	Coaxial cables	...	19	Check on amplifier and indicator	...	37
Exhaust gas thermometer and top temperature control (Code ET)	...	10	Cable boxes, code JX.13 and JX.15	...	20	Check on tank circuits	...	40
Operation	...	11	Cable boxes, code JX.12 and JX.14	...	21	Additional equipment required for checking wing tank system	...	48
Emergency fuel pump (Code EF)	...	12	Amplifiers, code FAB	...	22	Exhaust gas thermometer and top temperature control tests	...	49
Operation	...	13	Coaxial harness, code CG.1	...	23			
			Indicators	...	24	REMOVAL AND ASSEMBLY		
			Accuracy of fuel gauge installation	...	25	General	...	50

LIST OF TABLES

	Table		Table		Table			
Tank units	...	1	JX.14 cable boxes	...	7	System error	...	13
Fuselage tanks (port and starboard)	...	2	Amplifier capacitance/indicator current	...	8	Test points (port system)	...	14
Wing tanks (port and starboard)	...	3	Indicators	...	9	Test points (starboard system)	...	15
Coaxial cables	...	4	Temperature	...	10	Test points (wing system)	...	16
JX.13 and JX.15 cables boxes	...	5	Supply voltage	...	11			
JX.12 cable boxes	...	6	Fuel variations	...	12			
			Temperature variations acting on the fuel	...	12A			

LIST OF ILLUSTRATIONS

	Fig.	
Fuel contents gauges and fuel pressure warning	...	1
Oil pressure indicator	...	2
Tachometer	...	3
Emergency fuel pump	...	4
Exhaust gas thermometer and top temperature control (Routing)	...	5
Exhaust gas thermometer and top temperature control (Theoretical)	...	6
Fuel content gauge tank test points	...	7

INTRODUCTION

1. This group contains a description, including the method of operation, of the engine instruments, together with servicing information. Routing and theoretical diagrams of the installations are also included. For a general description of the instrument installation as a whole, reference should be made to Group 1 of this chapter. Detailed information on the standard components used, will be found in the relevant Air Publications, which are quoted in the appropriate paragraphs of this group.

DESCRIPTION

FUEL CONTENTS GAUGES AND FUEL PRESSURE WARNING (CODE FG AND FP)

2. This is a 28-volt electronic installation. The gauges, one for the port and one for the starboard fuel tanks, are located on the cockpit starboard shelf. They give a continuous summated indication of the front, centre and wing fuel tank contents irrespective of the aircraft's attitude. The port and starboard systems are entirely independent except for the common d.c. supply and differ only in that the port centre tank contains a few more gallons than that on the starboard side. The gauge for the port tanks is a Type AG.38, while that for the starboard tanks is a Type AG.39. The gauges, which are engraved in pounds (mass), are actuated by strap type capacitor gauge units fitted within each tank, via two Type FAB/03 amplifier units, located on the port side of the fuselage between frames 17B and 18A. The gauge units are connected to the amplifiers, via connector boxes, Type JX.12 and JX.14, located below the amplifiers, while those in the centre and wing tanks are, in addition, connected to relay boxes, Type JX.13 (port) and JX.15 (starboard), which are mounted on the rear face of frame 25. These relay boxes are energized by the operation of two fuel transfer pressure relays located on the supply panel and controlled by two Mk.1E* transfer pressure switches mounted between frames 24 and 25 in the centre fuselage. Apart from energizing the relay boxes, the transfer pressure relays also energize two Type C.1838Y Mk. 1 transfer

failure indicators located on the cockpit starboard shelf. Two Dowty Mk. 1 magnetic indicators are provided on the forward portion of the cockpit starboard shelf adjacent to the fuel gauges to indicate when the wing tanks are empty. These indicators are controlled by Flight Refuelling fluid level switches D.3504100/1 located one in each inboard wing tank. Since the drop fuel tanks have no gauges and feed into the wing tanks, it will be appreciated that the fuel gauges show 'full contents' until such time as the drop tanks are empty. A switch for use when it is required to check the fuel contents while the engine is not running is also provided on the starboard shelf. A warning lamp, mounted on the starboard instrument panel and controlled by a Mk.1E* fuel pressure switch situated on the engine, is provided to indicate low fuel pump delivery pressure. A routing and theoretical diagram of these circuits is given in fig. 1 of this group, while the fuel system as a whole is covered in Sect. 4, Chap. 2 of this volume. Reference should be made to A.P.1275A, Vol. 1, for a full description of the equipment, together with the principle of operation.

Operation

3. As each fuel gauge and its associated amplifier is separately fused and provided with independent control equipment, it is only necessary to follow the operation of one gauge to fully understand the circuit. The gauge and amplifier are both energized from the main positive supply and commence operation immediately the battery master switch is placed in the ON position. With transfer pressure in the tanks, the gauge will indicate the content of the front, centre and wing tanks, but if the fuel transfer pressure fails, so preventing fuel from being transferred from the centre and wing tanks to the forward tank, the transfer pressure switch will close. This will, in turn, energize the transfer pressure relay, which will energize the fuel gauge relay box and the transfer failure indicator. The indicator will thus give warning of transfer failure and the relay box will disconnect the centre and wing tank gauge units from the amplifier and insert a fixed capacitor into circuit the value

of which, corresponds to that obtained when the centre and wing tanks are empty. The gauge will, therefore, only indicate the fuel content of the front tank, as this is the only fuel available to the engine under conditions of fuel transfer pressure failure.

4. The contents check switch, which is marked ENGINE ON and ENGINE OFF is normally closed to complete the supply from the transfer pressure switch to the transfer pressure relay. This switch is used to check the total fuel contents when the engine is not running. As under this condition the required transfer pressure may not be available to open the transfer pressure switch and the centre and wing fuel tank gauge units will therefore be out of circuit, as described in para. 3 of this group. When the switch is opened by placing it in the ENGINE OFF position, the supply to the transfer pressure relay is broken and this in turn de-energizes the fuel gauge relay box, which will re-connect the centre and wing fuel tank gauge units to the amplifier, as during normal conditions.

5. The operation of the fuel pressure indicator circuit is such that when the engine pump delivery pressure falls below 2—2½ lb. per sq. in., the fuel pressure switch contacts close and make the supply to the warning lamp, which will be illuminated to give warning of this condition.

OIL PRESSURE INDICATOR (CODE OP)

6. This indicator is a Type I.A.C.R. a.c. ratiometer instrument mounted on the leg panel in the cockpit and actuated by a Type 482PG:FB, inductor transmitter mounted on the engine sump. The supply is obtained from the a.c. supplies circuit, via an auto transformer, as described in Sect. 5, Chap. 1, Group E.1 of this volume. A routing and theoretical diagram of the installation is given in fig. 2 of this group.

Operation

7. For the principle of operation and a full description of the equipment, reference should be made to A.P.1275A, Vol. 1.

RESTRICTED

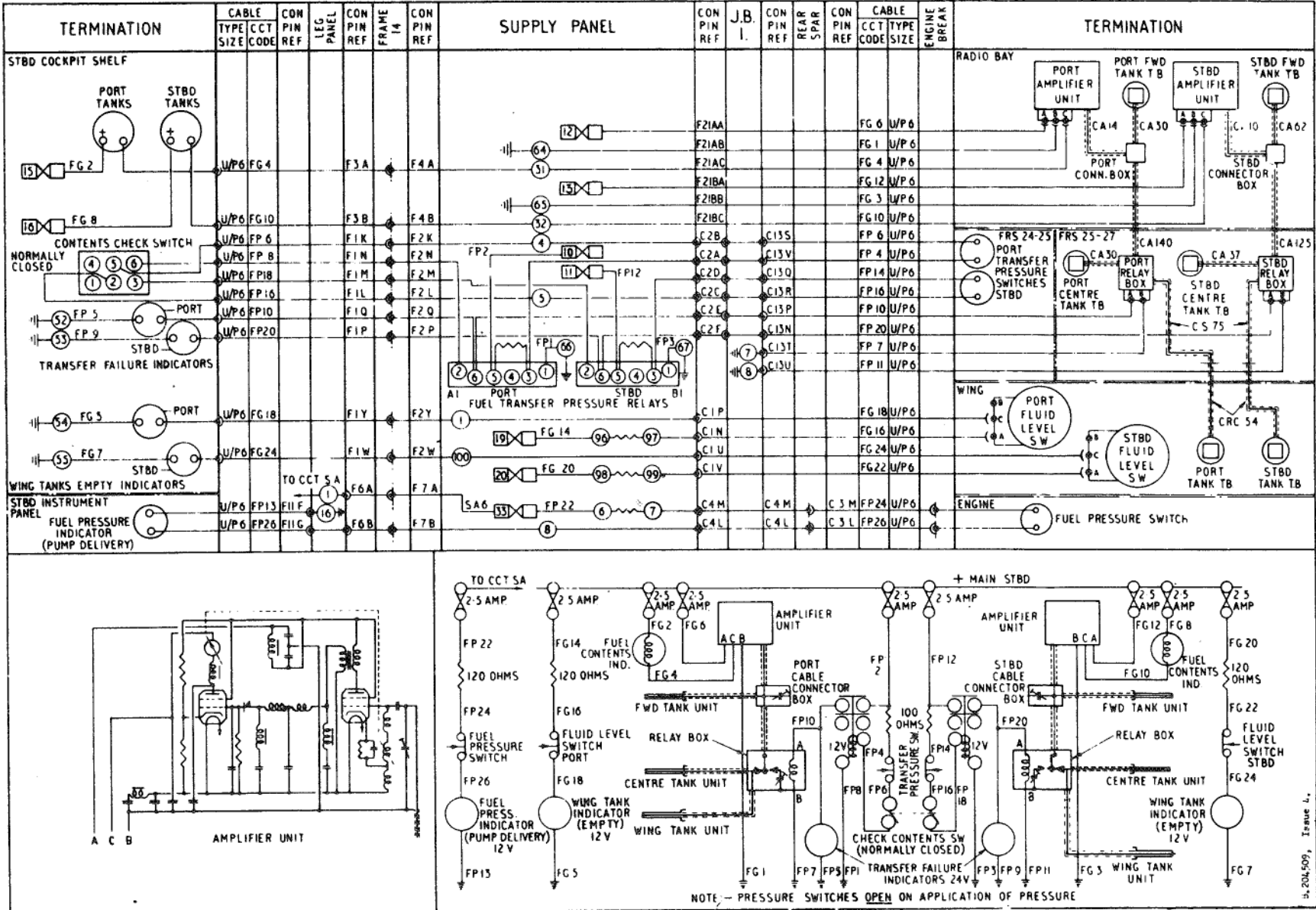

F.S./2

FIG. 1 FUEL CONTENT GAUGES AND FUEL PRESSURE WARNING RESTRICTED

(A.L.48, Sept.57)

A.204509, Issue 4.

TACHOMETER (CODE RA)

8. This indicator is a Mk. 10A electrically-operated instrument situated on the centre instrument panel and supplied with current from an engine-driven Mk. 8C tachometer generator located on the engine wheelcase. The indicator and generator form a closed circuit as shown in the routing and theoretical diagram given in fig. 3 of this group.

Operation

9. The principle of operation and a full description of the equipment will be found in A.P.1275A, Vol. 1.

EXHAUST GAS THERMOMETER AND TOP TEMPERATURE CONTROL (CODE ET)

10. The exhaust gas thermometer and top temperature control installation is provided to indicate and control the temperature of the engine jet exhaust gases, in order that the engine top temperature limits are not exceeded. The Type C exhaust gas thermometer is located on the centre instrument panel and gives a continuous indication of the jet exhaust temperature from 0 to 800 deg. C. The instrument is a moving coil millivoltmeter, which is actuated by eight Type B.6 thermocouples located in the jet pipe and the circuit incorporates a Samgamo Weston FD.871 adjustable series resistor mounted on the supply panel. The indicator, adjustable resistor and thermocouples form a self-energized closed circuit linked, via the thermocouples to the top temperature control equipment. The top temperature control installation is provided to restrict the throttle movement to compensate for a rise in exhaust gas temperature above the permissible maximum. The installation incorporates a Type EC.4/2 magnetic amplifier and a 14.85 ohms temperature trimmer resistor, which are both located at the top of the radio bay on the starboard side. The amplifier is fed with three phase a.c. taken from the a.c. supplies circuit and the unit amplifies the output of the eight thermocouples located in the jet pipe. The output from the amplifier is used to operate a throttle trimmer actuator, which

is located on the engine and linked with the throttle so as to partially close the throttle when the exhaust gas temperature is above the top limit and open it again when the temperature falls. The installation is only operative when the aircraft is airborne, being overridden by a Type C.1831/Y Mk. 2 micro-switch, which controls a Type FHM/A/58 time switch. The micro switch and time switch are located on the aft face of frame 3, the micro switch being operated by the nose wheel fairing door. An on/off cut-out switch is provided on the cabin port shelf to enable the installation to be rendered inoperative, in flight, if an emergency should make this necessary.

Operation

11. When the aircraft is airborne and the undercarriage retracted, the nose wheel fairing door micro switch is operated and energizes the time switch. After the required time sequence, the time switch contacts supply the magnetic amplifier, via the emergency cut-out switch when in the ON position, and render the installation operative. If the exhaust gas temperature, as measured by the thermocouples and fed to the magnetic amplifier, rises above the permissible maximum, the amplifier will feed the throttle trimmer actuator so that it partially closes the throttle. When the exhaust gas temperature falls, the output of the thermocouples will decrease and the amplifier will then feed the actuator in such a manner so as to again open the throttle. For a full description of the engine top temperature control equipment, together with the principle of operation, reference should be made to A.P.4343E, Vol. 1, Sect. 12. A full description of the exhaust gas thermometer, together with its principle of operation will be found in A.P.1275A, Vol. 1, Sect. 4.

EMERGENCY FUEL PUMP (CODE EF)

12. The two portions of the engine-driven duplex fuel pump are identical except for an isolating valve integral with the upper pump. The two portions are connected in parallel in

the engine fuel system and are controlled by a barometric pressure control unit. The isolating valve is provided as a safety device in the event of failure of either portion of the pump or the barometric pressure control. If one portion of the pump or the barometric pressure control fails, the other portion of the pump, if not isolated, will go into no stroke, thus causing subsequent engine failure. The isolating valve is solenoid operated and controlled by a ISOLATED/NORMAL switch located on the forward portion of the cockpit port shelf. A warning lamp, also mounted on this shelf is provided to indicate when the two portions of the pump are isolated from each other. This circuit is not operative on early aircraft, pending the introduction of an engine modification, and a locking guard is fitted to the switch of these aircraft.

Operation

13. The circuit is supplied from the engine starter master switch and is operative immediately this switch is placed in the ON position. The operation of the circuit will be apparent once reference is made to the routing and theoretical diagram given in fig. 4 of this group.

SERVICING**GENERAL**

14. Apart from the servicing information given in the following paragraphs, all other servicing to maintain the engine instruments in an efficient condition and the standard serviceability tests, which should be applied, together with the equipment to be used and the method of conducting the tests is contained in the appropriate sections of A.P.1275A and T, Vol. 1. Before servicing or removing any of the electrically-operated instruments the aircraft must be rendered electrically safe, as described in Sect. 5, Chap. 1, Group A1 of this volume.

FUEL CONTENTS GAUGES**Data and tolerances on units**

15. These figures are given in order that the units may be checked individually. The

following equipment should be used for carrying out the tests and must be of at least the accuracy stated:—

- (1) Variable capacitor — Range 100 to 2300 pF. Accuracy ± 1 pF at any point on its range.
- (2) Milliammeter * — Range 0 to 7.5 mA, 0 to 15 mA., 0–30 mA. Accuracy to BS.89 precision grade.
- (3) Voltmeter — Range 0 to 40 volts. Accuracy to BS.89 first grade.
- (4) FAB amplifier — Tested using the above instruments for conformation to the limits given in para. 22.
- (5) 250-volt d.c. insulation resistance tester.

* Alternatively, a d.c. potentiometer and standard resistance may be used.

Tank units

16. The initial capacitance quoted in table 1 is measured with the tank unit moist, but thoroughly drained of all kerosene fuel. The range of a unit is the increase in capacitance when totally immersed in a kerosene fuel, having a permittivity of 2.10 and specific gravity 0.779 at a temperature of 20 deg.C. Measurements must be carried out with the units well clear of all metal objects, and with the leads a minimum of three inches apart. A resistance of at least 20 megohms should be obtained for a new or replacement unit, dry before installation. To avoid any risk of an explosion, insulation resistance tests of installed

TABLE 1. Tank units

Code	Initial capacitance (pF.)	Range (pF.)	Tank
TC.94	227 \pm 3	243 \pm 3	Front
TC.95	287 \pm 3	304 \pm 3	Front
TC.96	181 \pm 3	184 \pm 3	Starboard centre
TC.97	188 \pm 3	193 \pm 3	Port centre
TC.180	50 \pm 3	53 \pm 3	Wing
TC.181	74 \pm 3	77 \pm 3	Wing
TC.182	74 \pm 3	77 \pm 3	Wing
TC.183	118 \pm 3	120 \pm 3	Wing

tank units should not be made under any circumstances.

Tank terminals

17. The capacitance of the tank terminals is as follows:—

Code—JKB1 Mod.01 Capacitance 17 \pm 3 pF.
 JM14 " 23 \pm 3 pF.
 JU6 " 23 \pm 3 pF.

The terminals should have an insulation resistance of at least 20 megohms.

Complete tank with tank terminal

18. The capacitance values for the tanks complete with terminals is given in tables 2 and 3. The insulation resistance of a complete tank installation, measured at the tank terminal coaxial socket should not be less than 1 megohm. It is preferable that tanks should be completely drained of all fuel before carrying out the above check.

TABLE 2. Fuselage Tanks
(Port and Starboard)

Tank	Empty, out of aircraft	Installed, wet and pressurized
Front	587 \pm 20 pF.	632 \pm 25 pF.
Centre (Port)	240 \pm 15 pF.	◀ 249 \pm 15 pF.
Centre (Starboard)	234 \pm 15 pF.	245 \pm 15 pF. ▶

RESTRICTED

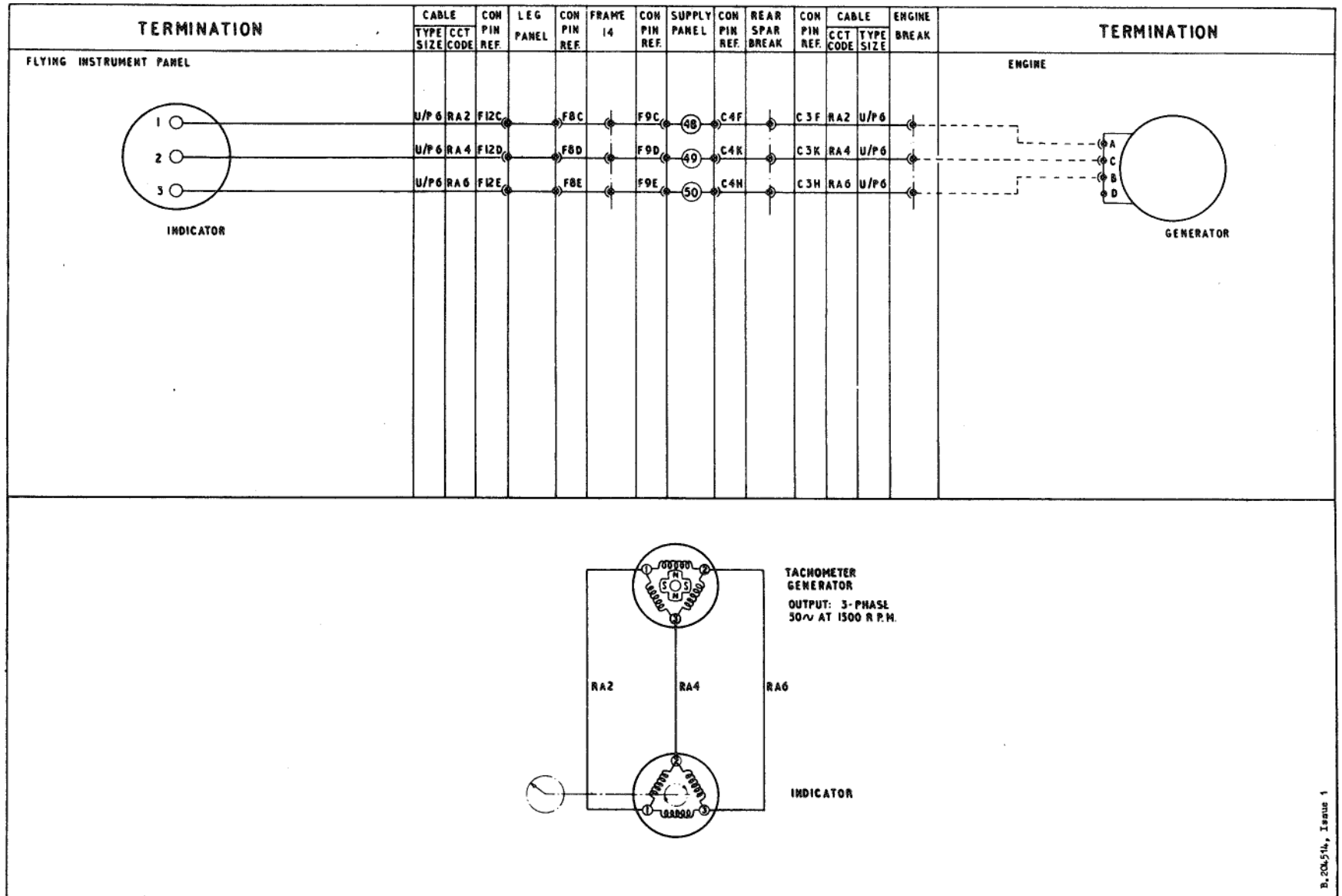

B.204514, Issue 1

FIG. 3. TACHOMETER
RESTRICTED

TABLE 3. Wing tanks
(Port and Starboard)

Tank	Empty, out of aircraft	Installed dry	Installed, wet and pressurized
No. 1	158±15 pF.	172±15 pF.	◀ 187 ± 19 pF.
No. 2	116±15 pF.	133±15 pF.	148 ± 19 pF.
No. 3	149±20 pF.	173±20 pF.	194 ± 32 pF. ▶
No. 4	88±15 pF.	102±15 pF.	110±15 pF.

Unusable fuel—NIL

Coaxial cables

19. Coaxial cables should have a resistance of at least 20 megohms whether new or installed. Cable details are given in Table 4

TABLE 4. Coaxial cables

Code	Length (in.)	Capacitance (pF.)
CA.10	10	18 ± 3
CA.14	14	26 ± 3
CA.30	30	54 ± 3
CA.37	37	67 ± 3
CA.62	62	111 ± 3
CA.125	125	225 ± 5
CA.140	140	252 ± 5
CRC.54	54	97 ± 3
CS.75	75	135 ± 3

Cable boxes, code JX13 and JX15

20. The capacitance figures given in table 5 for both these cable boxes are box values measured at the output socket, and with all tank system coaxial cables disconnected. The box capacitance with the relay open should be 15 ± 5 pF. in each case. The JX13 and JX15 cable boxes should have an insulation resistance of at least 20 megohms between the following points :—

TABLE 5. JX13 and JX15 cable boxes

Code	Box capacitance (relay closed)	
	Trimmer at min. not more than	Trimmer at max. not less than
◀ JX13 (Mod.01)	1157 pF	1349 pF
(Mod.02)	1160 pF	1398 pF
JX15 (Mod.01)	1166 pF	1358 pF
(Mod.02)	1169 pF	1407 pF ▶

TABLE 6. JX12 Cable boxes

Input socket	Tanks-empty capacitance into box		Tanks-empty capacitance out of box
	Trimmer at min. not less than	Trimmer at max. not more than	
Either	2351 pF.	2083 pF.	724 pF.
Input socket	Tanks-full capacitance into box		Tanks-full capacitance out of box
	Trimmer at min. not less than	Trimmer at max. not more than	
Either	3456 pF.	3188 pF.	1224 pF.

- (1) Pin A or B and earth with the relay unenergized.
- (2) Output socket and earth with the relay unenergized.
- (3) Output socket and earth with the relay energized.

Note . . .

The tank circuit should be disconnected during the check.

Cable boxes, code JX12 and JX14

21. A JX12 or JX14 box should be checked by connecting the 'capacitance into box' figure given in table 6 or 7 into first the socket normally connected to the front tank, and then into that normally connected to the JX13 or JX15 cable box. In each case, the capacitance out of box should remain the same. It will be seen in each table that the capacitance out of box figure is the 'tanks empty' or 'tanks full' capacitance of the amplifier less the capacitance of the connecting cable. If, therefore, the box is connected to the FAB amplifier used for the test by either the CA14 cable in the case of the JX12, or the CA10 cable in the case of the JX14, the amplifier's output should be 2 mA

TABLE 7. JX14 Cable Boxes

Input socket	Tanks-empty capacitance into box		Tanks-empty capacitance out of box
	Trimmer at min. not less than	Trimmer at max. not more than	
Either	2390 pF.	2122 pF.	732 pF.

Input socket	Tanks-full capacitance into box		Tanks-full capacitance out of box
	Trimmer at min. not less than	Trimmer at max. not more than	
Either	3480 pF.	3212 pF.	1232 pF.

or 7 mA., depending on which capacitor test value is connected into the box's input socket. The full testing procedure is described in A.P.1275T, Vol. 1. As each cable box contains a coil connected to earth, it is useless to subject them to an insulation resistance test. These units may be considered serviceable if they conform to the capacitance figures given in the tables.

Amplifiers, code FAB

22. The relationship between the indicator current and capacitance with a power supply of 28 volts is given in Table 8. The amplifiers contain a 150-volts working condenser, which would be damaged by the higher Megger voltage, thus an insulation resistance test must not be carried out on these units. They may be considered serviceable if they conform to the capacitance/indicator current test figures given in the table using the accurate test equipment referred to in para.15.

TABLE 8

Amplifier capacitance/indicator current

Capacitance (pF.)	Indicator current (mA.)
750	2.0 ± .03
823	3.0 ± .05
908	4.0 ± .05
1005	5.0 ± .05
1120	6.0 ± .05
1250	7.0 ± .05

Power supply: Nominal voltage 28 volts.
Current at 28 volts 0.7 amp. (approx.)

Capacitance: Initial (or tanks empty) ... 750 pF.
Tanks full ... 1250 pF.
Range ... 500 pF.

TABLE 9—Indicators

* Actual figure is 6.725. A reading of 6.72 or 6.73 is therefore, acceptable.

Code AG. 38		Code AG. 39	
Indication (pounds X 100)	Indicator Current (mA.)	Indication (pounds X 100)	Indicator Current (mA.)
0	2.00	0	2.00
1	2.35	1	2.33
2	2.73	2	2.73
3	3.14	3	3.16
4	3.53	4	3.57
5	3.92	5	3.95
6	4.25	6	4.28
7	4.58	7	4.59
8	4.90	8	4.93
9	5.22	9	5.25
10	5.50	10	5.55
11	5.78	11	5.84
12	6.04	12	6.10
13	6.29	13	6.34
14	6.50	14	6.57
15	*6.72	15	6.81
16	6.96	16.05	7.00
(F) 16.28	7.00		

Coaxial harness, code CGI

23. The capacitance of the coaxial harness is 136 ± 5 pF. and it should have an insulation resistance of at least 20 megohms.

Indicators

24. An insulation resistance test should not be carried out on the indicators. These may be considered serviceable if they conform to the figures given in Table 9.

Accuracy of the fuel gauge installation

25. It will be realised from the nature of the system that its accuracy depends on the supply voltage being maintained at the required figure and the physical properties of the fuel conforming to specification. Any small inaccuracies which may exist will usually stem from these two sources. The calibration of this gauge is based on a kerosine fuel having a permittivity of 2.10 and a specific gravity 0.779 at a temperature of 20 deg.C.

Errors of the fuel gauge in normal flight

26. The following tables will enable an operator to obtain an approximate error from true reading caused by system inaccuracies and by various conditions of temperature, supply voltage, fuel permittivity and density. All errors are expressed as a percentage of the total indication.

TABLE 10—Temperature

Temperature	-35°C	-10°C	+15°C	+40°C
Tank empty	+0.8	+0.4	0	-0.4
1/10	+1.0	+0.5	0	-0.5
1/3	+1.4	+0.7	0	-0.7
2/3	+2.0	+1.0	0	-1.0
Full	+2.6	+1.3	0	-1.3

TABLE 11—Supply voltage

Supply voltage	24V.	28V.	29V.
All fuel levels	-1.5	0	+0.8

Note . . .

The fuel contents gauge is calibrated for a supply voltage of 28 volts d.c. To obtain maximum accuracy, the voltage must be adjusted to this figure.

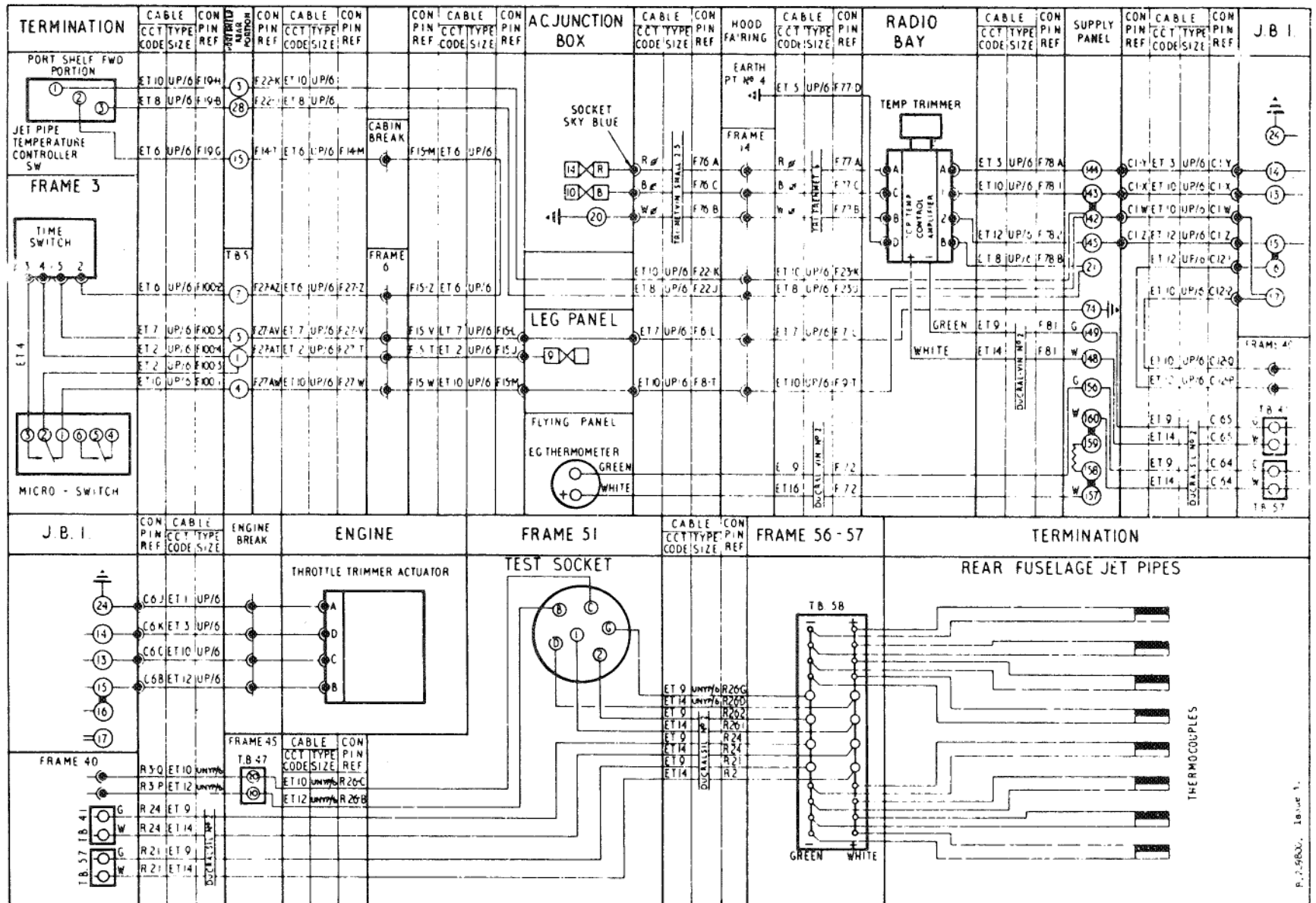

F.S./6

(A.L.48, Sept.57)

FIG. 5 EXHAUST GAS THERMOMETER AND TOP TEMPERATURE CONTROL (ROUTING)

RESTRICTED

P. 2-51800, Issue 1.

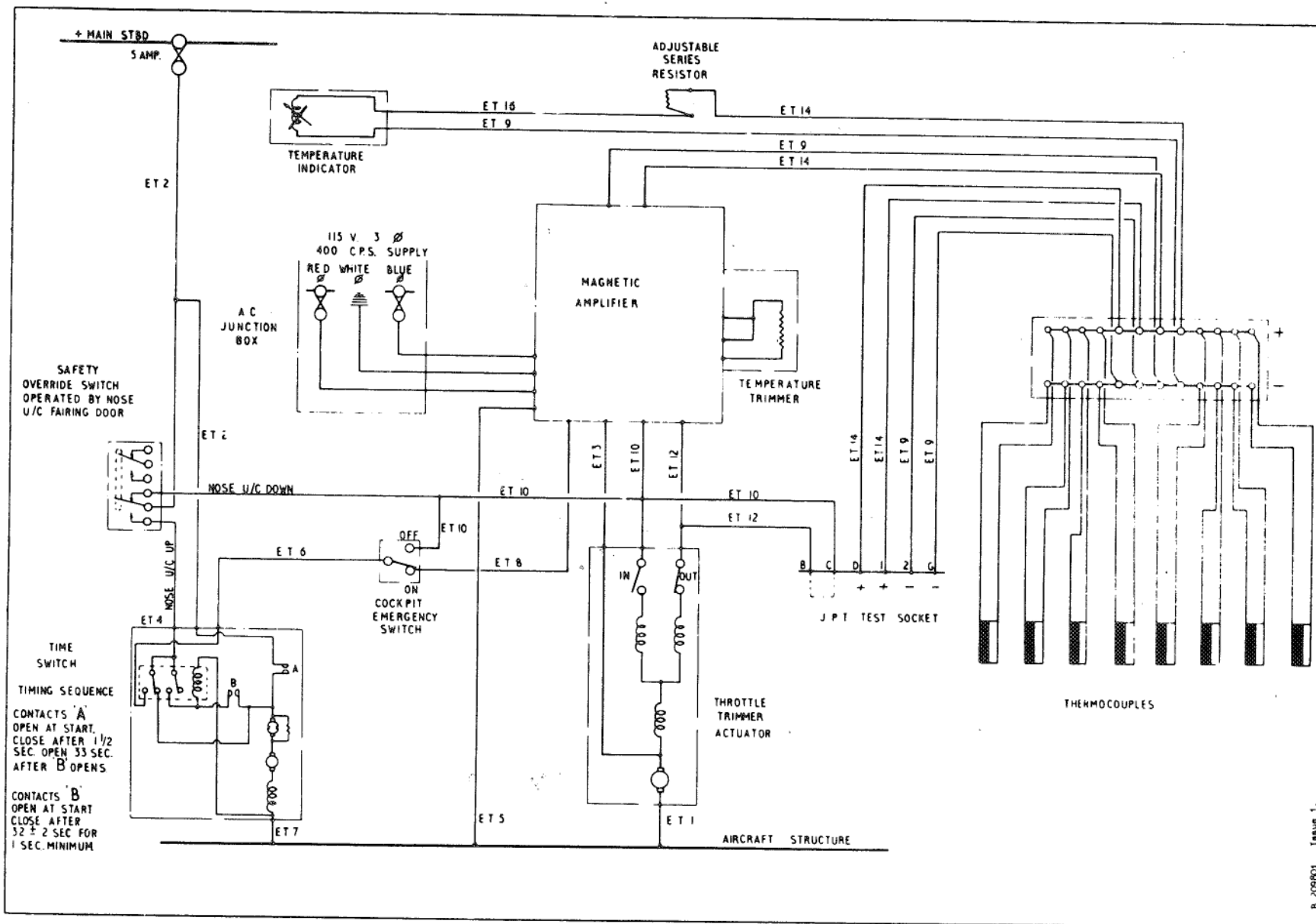

FIG. 6 EXHAUST GAS THERMOMETER AND TOP TEMPERATURE CONTROL (THEORETICAL)

RESTRICTED

◀ **TABLE 12**
Fuel variations

(1) Fuel	(2) Permittivity k	(3) Density gm/ml. d	(4) % Errors				
			Tank empty	1/10	1/3	2/3	Tank full
BRITISH							
AVTAG, DERD2486 (J.P.48 or F-40)	2.035 2.180	0.739 0.825	0 0	-0.08 +0.1	-0.3 +0.4	-0.6 +0.8	-0.8 +1.3
AVTUR, DERD2482 (J.P.1B or F-33)	2.035 2.165	0.780 0.810	0 0	-0.6 +0.2	-2.0 +0.6	-4.0 +1.2	-6.0 +1.8
AVCAT, DERD2488 (J.P.5B or F-42)	2.156 2.161	0.817 0.817	0 0	0 +0.05	0 +0.17	0 +0.33	0 +0.5
AMERICAN							
J.P.1 (MIL-F-5616 or F-33)	2.093 2.186	0.8030 0.8479	0 0	-0.4 -0.09	-1.2 -0.3	-2.4 -0.6	-3.7 -0.9
J.P.3 (MIL-F- 5624C)	1.997 2.270	0.7434 0.8300	0 0	-0.5 +0.8	-1.6 +2.8	-3.2 +5.6	-5.0 +8.3
J.P.4 (MIL-F-5624C or F-40)	2.020 2.106	0.7467 0.8251	0 0	-0.3 -0.5	-1.1 -1.7	-2.1 -3.4	-3.2 -5.1

Note . . .

(A) The figures given in Table 12 will enable an operator to calculate errors when using fuels differing in permittivity and density to those for which the gauge is calibrated (para. 25). It should be borne in mind that the errors given in column (4) of Table 12 are not extreme errors to be expected when using the fuels defined in column (1). The errors given are those which may be present when using fuels conforming to the permittivities and densities quoted in columns (2) and (3). The errors given have been calculated from the "highest" and "lowest" values obtained by laboratory measurement of fuel samples.

Note . . .

(B) Since fuel permittivity does not always vary exactly in relation to density, an error may exceed that quoted or the sign of an error may reverse. Should a fuel be employed which differs to that defined in columns (2) and (3), the mass indication for that fuel will be in error by a factor equal to $\frac{k-1}{d} \frac{d_0}{k_0-1}$; that is to say, the capacitance index of the fuel divided by that for the standard.

TABLE 12 A.
Temperature variations acting on the fuel

Condition	% Error
Temperatures above +20deg.C.	-0.028/°C
Temperatures below +20deg.C.	+0.028/°C
For 50 deg. C. fall in temperature	+1.40
For 50 deg. C. rise in temperature	-1.40

Note . . .

The correction to be made to the indicator reading, to indicate true contents, is equal in magnitude but opposite in sign to the error given ▶

TABLE 13—System error

Tanks empty	± 0.3*
◀ 1/10	± 0.8*
1/3	± 2.0*
2/3	± 3.7*
Full	± 5.7* ▶

* Includes 0.3 per cent. readability error.

Note . . .

Each unit of the fuel gauge is manufactured to a particular capacitance with an associated tolerance. It is, therefore, possible, although unlikely, for all these to be either high or low on tolerance. For this reason, Table 13, quoting the maximum system errors, is given.

Setting up fuel contents gauges

27. Before commencing to set-up the fuel gauges, ensure that the power supply to the amplifier is switched on for at least 15 minutes, by placing the battery master switch to the ON position or by connecting an external supply to the aircraft's electrical system. The recommended setting-up instructions are as follows:—

- (1) The supply voltage is to be 28 ± 0.5 volts.
- (2) Fill and then drain the complete fuel system to the unusable fuel level.
- (3) Pressurize the fuel system to the normal working pressure.
- (4) Trim summation circuits to zero, using the three trimmers marked TRIM SUM in the cable boxes JX.12 and JX.14.
- (5) Depressurize the fuel system.
- (6) Trim the wing and centre matching circuits to zero, using the three trimmers marked TRIM O/C in the relay boxes JX.13 and JX.15.

Checking the fuel gauge installation

28. Apart from the normal inspection for physical damage, the installation on this aircraft requires no maintenance during service other than the functional (or tanks drained) check. The fault location checks should be carried out, using the code QAA test set, which is described in A.P.1275T, Vol. 1. The figures quoted for these checks should only be employed as a guide when

using the QAA test set, the necessary standard of accuracy not being obtainable with this instrument. If, however, a unit appears to deviate greatly from the figures quoted, it should be removed from the aircraft and checked, using the accurate test equipment referred to in para. 15, or alternatively, replaced by a new unit and the fault location test repeated. On no account should a unit be rejected solely on the evidence of the test set.

29. It is permissible to change a valve in an amplifier, but this must be replaced only by a Code ZAA valve supplied by Smiths Aircraft Instruments, Ltd. After a valve replacement has been carried out the amplifier must pass a capacitance indicator current test (para. 22), again using the accurate equipment referred to previously.

Functional check

30. This check should be carried out at the times quoted in the aircraft Servicing Schedule or after any major unit of the installation is changed. The check ensures a correct reading on the indicators when the tanks are drained of all normally usable fuel, and thus acts as a guide to the correct operation of the gauge. Each side of the system must be checked separately and, therefore, the following procedure must be followed out on each in turn.

31. Before commencing this test, the system should be pressurized to the normal working pressure, the tanks must also have been recently filled and then drained of all normally usable fuel. It is important to note that 15 minutes should be allowed to elapse to enable the tank units to completely drain, otherwise the tank units will have a higher capacitance than that quoted. In addition, the power supply to the amplifier must be switched on at least five minutes before the check is carried out.

32. If these conditions obtain, the indicator should read zero contents. If not, the trimmers in either JX.12 or JX.14 cable box must be revolved until the indicators give a satisfactory reading.

33. The systems should now be depressurized. The CHECK CONTENTS switch set to ENGINE ON so that the dummy capacitances for the wing and centre tanks are now connected to their respective amplifiers. The indicator should still show zero contents, but if not, the trimmers in the JX.13 or JX.15 cable box should be used to obtain the desired reading. Whilst it is immaterial which trimmers are used to effect adjustment, under certain conditions difficulty may be experienced in setting the indicator to zero contents, in either the pressurized or unpressurized state. If such is the case, it will be necessary to adjust the trimmers of the cable box involved to the maximum capacitance setting utilising the QAA test set for the purpose.

34. The QAA test set should not be connected to any part of the circuit whilst carrying out a zero contents check. It must be realised that this check in no way guarantees the accuracy of the system throughout the range and that if this is suspect the units should be individually tested with the equipment listed in para. 15.

Insulation resistance check

35. An insulation resistance check should be carried out periodically with at least the same frequency as this check is made on the remainder of the aircraft's electrical system. Using a 250 volt insulation resistance tester, the individual units should conform to the tolerances laid down in para. 16 to 24. It is important to note that insulation resistance checks should not be carried out on amplifiers, cable boxes, tank units and indicators for the reasons stated previously, and that it is preferable that the tanks are completely drained of all fuel before the checks are commenced.

Fault location checks

36. Apart from a failure in the 28 volt supply, a fault in the installation will only affect one indicator and, therefore, in the great majority of cases, it will only be necessary to carry out a check on the one system. The method of testing each system is identical, but the test values are naturally a little different owing

to certain cable dissimilarities. These necessitate the two tables 14 and 15 found in this chapter.

Check on amplifier and indicator

37. The first part of a fault location check is carried out by connecting the test set between an amplifier and its power supply as described in A.P.1275T, Vol. 1. Move the test set's selector switch first to position 1 and then to position 2, thereby checking the power supply and current respectively into the amplifier by noting the test set meter reading; this procedure is explained in greater detail in the above Air Publication. If an unsatisfactory result is obtained, check back to the source of the power supply.

38. To test the circuit between an amplifier and indicator, turn the test set's selector switch to position 3. As the output of the FAB amplifier varies between approximately 2 and 7 mA. over the range of 'tanks empty' to 'tanks full', it follows that the test set meter reading should lie between these two limits, depending on the amount of fuel on board. If a satisfactory reading is not obtained, the fault could lie either with the amplifier and associated tank circuit or with the indicator and its circuit. To check which of these two is at fault, move the selector switch to position 4. This cuts out the circuit to the indicator, and if a satisfactory result is still not obtained, the fault must lie in the amplifier or in the tank circuit. If a satisfactory reading is obtained, the fault lies in the indicator circuit. The foregoing procedure is explained at greater length in A.P.1275T, Vol. 1 and a table that summarises it appears in that publication and on the lid of the test set itself.

39. Now disconnect the tank circuit coaxial cable from the amplifier and substitute the coaxial cable supplied with the test set,

connecting the other end of the cable to either of the test set's two coaxial sockets. This arrangement is also shown in A.P.1275T, Vol. 1. As the test set's cable has a capacitance of 150 pF., if the variable capacitor on the set is adjusted to 600 pF., a capacitance of 750 pF. will be fed into the amplifier. Thus, if the selector switch is placed at position 3 or 4 the test set meter should read about 2 mA. This procedure should be repeated for each of the settings given in table 8 and the amplifier checked for approximate accordance with the values given.

Check on tank circuits

40. It will be seen in fig. 7 that every connection or test point is numbered, starting at the cable box and working to the tanks. These numbers will be found in Tables 14 and 15, together with the capacitance that must be connected at each point to give an indication of approximately 2 mA. on the test set meter and therefore a reading of zero contents on the indicator.

41. When testing at beyond points 3, 7 and 10 it is essential that the tanks be drained of all normally usable fuel and the system pressurized. If the amplifier has proved serviceable, reconnect the aircraft's coaxial cable to the amplifier and disconnect it at point 1 of the associated system. The test set's coaxial cable must now be connected to the aircraft's cable, employing the double socket clipped to the inside of the test set's lid.

42. The variable capacitor should now be set to 750 pF., less the capacitance of the aircraft's CA10 or CA14 cable, test set cable and the socket; the resultant value is the figure given in the table. The indicator should now read approximately zero contents and the test set's meter about 2mA. This process is repeated at each of the remaining points throughout the system, the variable capacitor value being set to the figures given

in the appropriate table as each unit is connected back into the installation until a complete check has been made.

43. The capacitance values given have the total tolerance at each particular point quoted alongside. The desired meter reading of 2mA. should, therefore, be obtainable with the variable capacitor setting within these limits, provided that the system's trimmers are correctly adjusted. On no account should the cable box trimmer settings be altered; these settings should only be adjusted during a functional check.

44. The method of checking the units installed in the port and starboard wing tanks is a little different to that described in the preceding paragraphs, and is therefore described below.

45. Disconnect the coaxial harness CG1 at points A, B, C and D (*fig. 7*) and connect the QAA test set to the amplifier as described in A.P.1275T, Vol. 1. Using a suitable length of coaxial cable and a Pye Waymouth adaptor join the spare coaxial socket to any point of the harness. The variable capacitor should now be set to give a milliammeter reading of, say, 5 mA., and the harness disconnected, leaving a coaxial cable and adaptor all connected to the test set socket. Having noted the variable capacitor reading, it should be readjusted until the same milliammeter reading is again recorded. The capacitance of the CG1 harness is obtained by subtracting the first variable capacitor reading from the second, and should be within the limits quoted in para. 23, plus ten per cent allowance for test set inaccuracies. This method is described in greater detail in A.P.1275T, Vol. 1.

46. Assuming that the harness is serviceable, leave it disconnected and also disconnect the coaxial cable CRC.54 from the JM.14 tank terminal. Employing the method detailed for the CG1 harness, now check each tank at points A, B, C and D for accordance with the capacitance values given in table 16.

TABLE 14. Test points (port system)

Test Point	A Test capacitance (pF.)	B Test capacitance (pF.)	Adaptors and cables used	Approximate reading on	
				Aircraft's Indicator	Test set meter
1	724 ± 3	570 ± 8	CC3 and CE1	Zero contents	2 mA
2	686 ± 28	536 ± 31	CE1		
3	632 ± 25	478 ± 30	CC3 and CE1		
4	1585 ± 127	1435 ± 130	CE1		
5	1333 ± 122	1179 ± 127	CC3 and CE1		
6	303 ± 23	153 ± 26	CE1		
7	249 ± 20	95 ± 25	CC3 and CE1		
8	1030 ± 99	880 ± 102	CE1		
9	895 ± 96	737 ± 101	CC1 and CE1		
10	798 ± 93	640 ± 98	CC1 and CE1		

TABLE 15. Test points (starboard system)

Test Point	A Test capacitance (pF.)	B Test capacitance (pF.)	Adaptors and cables used	Approximate reading on	
				Aircraft's Indicator	Test set meter
1	732 ± 3	578 ± 8	CC3 and CE1	Zero contents	2 mA
2	743 ± 28	593 ± 31	CE1		
3	632 ± 25	478 ± 30	CC3 and CE1		
4	1562 ± 127	1412 ± 130	CE1		
5	1337 ± 122	1183 ± 127	CC3 and CE1		
6	307 ± 23	157 ± 26	CE1		
7	245 ± 20	91 ± 25	CC3 and CE1		
8	1030 ± 99	880 ± 102	CE1		
9	895 ± 96	737 ± 101	CC1 and CE1		
10	798 ± 93	640 ± 98	CC1 and CE1		

47. The values quoted in column A of tables 14 and 15 are the true capacitances to be connected at each point, whilst those in column B are the true capacitances less the capacitance of the connecting cables and/or sockets. In other words, the values in column B are the actual test set variable capacitor settings, and the values in column A are the theoretical values. Both are given so that an operator may make allowances accordingly should he use a different method of connection.

TABLE 16. Test points (Wing system)

Point into which test capacitance is connected	Value of tank unit, plus internal wiring, measured at tank terminal
A	187 ± 19
B	148 ± 19
C	194 ± 32
D	110 ± 15

Additional equipment required for checking wing tank system

48. The equipment issued with the standard QAA Mod. 02 test set is insufficient when checking aircraft and/or components fitted with Pye coaxial plugs and sockets. On this

particular aircraft, the wing tank system is so equipped. To meet this requirement, the following additional item with its capacitance value is given below and may be obtained through the usual channels :-

Pye Weymouth adaptor, Code CC1,
Capacitance 8 ± 2 pF.

EXHAUST GAS THERMOMETER AND TOP TEMPERATURE CONTROL TESTS

49. These tests should only be carried out when the thermocouples are at normal ambient temperature, thus after an engine run

a reasonable time must be given to allow them to cool before the tests are made. Unless this precaution is observed considerable error will occur in the readings. Before commencing to test the installation, ensure that the resistance of the compensating leads F.81, C.65 and R.24. between the magnetic amplifier and T.B.58 do not exceed 20 ohms and that the resistance of the compensating lead R.26 from the test socket to T.B.58 is $0.86 \pm .02$ ohms. Also check that the resistance at the exhaust gas temperature indicator terminals, with the indicator disconnected is $8 \pm .10$ ohms. If not, adjust the resistance by removing windings from the spool of the adjustable series resistor. When the resistance is correct, cut off at approximately one foot additional length, cover this length with 1 mm. inside diameter P.V.C. tubing and rewind on the the spool. When all the above conditions are obtained, proceed as follows:—

- (1) Check that the a.c. supply on invertors No. 1 and No. 2 is $115V \pm 5\%$ 400 c/s $\pm 5\%$ 3 phase. This can be checked on the compass test point with Sperry a.c. supply tester S.E.863. adjust voltage control Type 12 until obtained.
- (2) Adjust the variable controls on the Ultra Q.E.2210 test set marked MILLIVOLTS COARSE and FINE to the minimum position (anti-clockwise).
- (3) Adjust the meter (I) so that the pointer indicates the ambient temperature as obtained from the panel thermometer.
- (4) Connect the test set to the aircraft's test plug by means of connector Q.Y.2212-18.
- (5) Set the switch on the test set marked METER I/STANDARD to position METER I and the SUPPLY switch to position INT supply.
- (6) Ensure that the safety over-ride switch in the nosewheel bay is unoperated.
- (7) Connect up an external d.c. supply.

- (8) The actuator should operate, or will be in the fully retracted position, and the meter III pointer on the test set should be fully deflected on the rich side.
- (9) Ensure that the jet pipe control switch is in the OFF position. Depress the nosewheel over-ride micro switch and lock in this position.
- (10) On completion of the time switch cycle of 32 ± 2 sec., meter III pointer should again be fully deflected on the rich side.
- (11) Select the jet pipe control switch to the ON position.

Note . . .

Meter III pointer on test set should be in the centre zero position.

- (12) Set the selector switch on the Ultra test set to range "F".
- (13) Set aircraft throttle control to the required datum position.
- (14) Start No. 1 or No. 2 aircraft inverter, and allow to run for 5 mins.
- (15) Gradually increase the coarse and fine M.V. controls, until the Meter I in the test set reads just below 700 deg. C. Check that the pilot's temperature indicator is giving the same reading. If not adjust by means of the zero adjusting screw. It should be noted that after such movement of the zero adjusting screw the screw must be turned in the opposite direction by a fraction of a turn to relieve the stresses in the compensating adjustment.
- (16) Adjust the input on coarse and fine M.V. controls until Meter I reads 700 deg. C, and then gradually increase it, taking readings at the following points.
 - (a) When the actuator begins to inch so as to reduce the fuel flow. (Indicated by the meter pointer M. III oscillating from the mid scale position to about 1/3 full scale deflection on the weak side).
 - (b) When the actuator ceases to inch and begins to move continuously (Indicated by the meter pointer

coming to rest at about 1/3 full scale deflection on the weak side).

- (17) Continue increasing the input potential until the actuator stops in the fully weak position. (Indicated by Meter pointer M. III being fully deflected on the weak side). Then reduce the input to simulate the normal control temperature again (700 deg. C.) and repeat the procedure in the reverse direction. The meter readings this time will be on the rich side of the scale.
- (18) The mean of the two readings when the actuator just commences to inch on the rich and weak side should be 700 ± 5 deg. C. The readings when the actuator ceases to inch and begins to move continuously should be approx. 25 deg. C. above and below 700 deg. C.
- (19) If the input readings are not within the above limits, apply correction by means of the reference voltage adjustment on the amplifier unit.

Note . . .

A dead band of approximately 6 deg. C. is present in the amplifier, i.e., ± 3 deg. C. on either side of the selected datum temperature (700 deg. C.).

- (20) Operate the two-way key switch marked TEST/SET to the SET position and repeat the appropriate tests in operations 16 to 19. If the input readings are not the same as before it indicates that one or more of the thermocouples is open or short-circuited.

Note . . .

This switch substitutes an equivalent resistance in place of the thermocouples.

REMOVAL AND ASSEMBLY

50. The removal of the instrument panels and cockpit shelves carrying the engine instruments are fully described in Group 1 of this chapter, together with an illustration showing the location of all the components. Once access has been obtained, the removal of the remaining items of equipment should present no unusual difficulties.

This file was downloaded
from the RTFM Library.

Link: www.scottbouch.com/rtfm

Please see site for usage terms,
and more aircraft documents.

