

Group 3 FLYING INSTRUMENTS

LIST OF CONTENTS

	<i>Para.</i>		<i>Para.</i>
<i>Introduction</i>	1	<i>Turn and slip indicator (Code TS)</i>	11
DESCRIPTION		<i>Rudder and aileron tab indicators</i>	13
<i>Air speed indicator</i>	2	<i>Tail plane position indicator</i>	14
<i>Machmeter</i>	3	<i>Flap position indicator</i>	15
<i>Altimeter</i>	4	<i>Clock</i>	16
<i>Cabin altimeter</i>	5	<i>V.G. recorder and accelerometer</i>	17
<i>Rate-of-climb indicator</i>	6	SERVICING	
<i>Pressure head installation</i>	7	<i>General</i>	18
<i>Gyro compass (Code C)</i>	8	<i>Pressure head drain traps</i>	19
<i>Stand-by compass</i>	9	<i>Pitot-static system leak tests</i>	20
<i>Artificial horizon (Code H)</i>	10	REMOVAL AND ASSEMBLY	21

LIST OF ILLUSTRATIONS

	<i>Fig.</i>
<i>Pressure head installation</i>	1
<i>Gyro compass</i>	2
<i>Artificial horizon</i>	3
<i>Turn and slip indicator</i>	4

Introduction

1. This group contains a description of the flying instruments installed in this aircraft, together with details of the pressure head installation and, where necessary, the operation of the installations is also included. The necessary servicing details required to maintain the equipment in an efficient condition, together with routing and theoretical diagrams

of the electrically-operated instruments, are also included. For a general description of the aircraft's instrument installation as a whole, reference should be made to Group 1 of this chapter. Detailed information on the standard components used will be found in the relevant Air Publications, which are quoted in the appropriate paragraphs of this group.

DESCRIPTION

AIR SPEED INDICATOR

2. The air speed indicator is mounted on the port side of the centre instrument panel and is a Mk. 12A capsule type instrument operated by air pressure drawn from the pressure head installation, which is described in para. 7 of this group. For a full description of the indicator, reference should be made to A.P.1275B, Vol. 1.

MACHMETER

3. The machmeter is installed on the port side of the centre instrument panel adjacent to the air speed indicator. It is a Mk. 3A instrument provided to give a continuous indication of the ratio of true air speed to the speed of sound, this ratio being known as the Mach No. The instrument is operated by the pressure and static pipe-lines from the pressure head (para. 7).

ALTIMETER

4. The Mk. 19A altimeter is located on the port side of the centre instrument panel just below the air speed indicator. It is an atmospheric pressure operated instrument provided to give a continuous indication of the aircraft's height. The instrument is connected to the static pressure pipe-line of the pressure head installation, described in para. 7 of this group. For detailed information of the instrument, reference should be made to A.P.1275B, Vol. 1.

CABIN ALTIMETER

5. This instrument is a Mk. 18 aneroid indicator, located on the starboard instrument panel just above the oxygen gauge. It is not connected to the pressure head installation

or to any other instrument, but is open to the air in the cockpit, as it indicates the equivalent pressure cabin altitude and not the aircraft's height.

RATE-OF-CLIMB INDICATOR

6. A Mk. 3A (P) rate-of-climb indicator is installed on the starboard side of the centre instrument panel adjacent to the artificial horizon. It is a sensitive differential pressure gauge giving the rate of change of the atmospheric pressure in terms of rate of climb or descent, whenever the aircraft departs from level flight. The instrument is connected to the static pressure pipe-line of the pressure head installation, described in para. 7 of this group. For a full description of the instrument, reference should be made to A.P.1275A, Vol. 1.

PRESSURE HEAD INSTALLATION

7. This installation operates the air speed indicator, machmeter, altimeter and rate of climb indicator. The installation (fig. 1) consists of a Mk. 9A electrically-heated pressure head, projecting forward from the port wing tip. The pressure head contains the pressure and static pipes, which are connected to the instruments, via the pressure and static connectors, mounted on the port forward face of the centre instrument panel, by a system of pipe-lines. Moisture in the pipe-lines is collected by a number of drain traps located in each pipe-line as illustrated in fig. 1. For details of the pressure head electric heater circuit, reference should be made to Sect. 5, Chap. 1, Group F2 of this volume, while a full description of the pressure head will be found in A.P.1275A, Vol. 1.

GYRO COMPASS (CODE C)

8. The Type A gyro unit of the GM4F gyro compass installation is situated on the centre line of the centre instrument panel, just below the artificial horizon. It is an electrically-operated directional gyro, which is synchronized to the earth's magnetic field by a remote Type A detector unit, located in the port tail plane, and provides continuous indication of the aircraft's magnetic heading. The installation, which also incorporates a Type A precession amplifier and a corrector control box, both of which are

located on the starboard side of the cockpit, is supplied with three-phase a.c. and d.c. for compass correction, from the a.c. supplies circuit, as described in Group E1 of Sect. 5, Chap. 1 of this volume. A routing and theoretical diagram of the installation is given in fig. 2 of this group, but for a full description of the compass and the principles of operation, reference should be made to A.P.1275B, Vol. 1.

STAND-BY COMPASS

9. A Type E2A stand-by compass, for use should the gyro compass fail, is mounted on a bracket attached to the gun sight mounting structure just above the starboard side of the centre instrument panel.

ARTIFICIAL HORIZON (CODE H)

10. The Mk. 4 artificial horizon is fitted on the centre instrument panel, just above the gyro compass. It is an electrically-operated gyroscopic instrument providing a continuous indication of the aircraft's attitude in roll and pitch in relation to the natural horizon and is supplied with three-phase a.c. from the a.c. supplies circuit, as described in Group E1 of Sect. 5, Chap. 1 of this publication. For a detailed description of the installation, together with the principle of operation, reference should be made to A.P.1275A, Vol. 1; a routing and theoretical diagram of the installation is, however, given in fig. 3 of this group.

TURN AND SLIP INDICATOR (CODE TS)

11. This indicator is fitted on the starboard side of the centre instrument panel, just below the rate-of-climb indicator, to provide an indication of the aircraft's lateral attitude in relation to level flight and to indicate skid, side slip or correct bank during a turn. It is a Mk. 2 electrically-operated instrument supplied from the normal 24-volt d.c. supply and provided with duplicated fuses which are located on the leg panel. The supply from the fuses to the instrument is controlled by a relay, which is also located on the leg panel, and the circuit is energized immediately the battery master switch is placed in the ON position.

12. Switching on the battery master switch energizes the coil of the turn and slip relay, via the normal circuit fuse, and the contacts of the relay, which are made while the relay is energized, feed the supply from the normal fuse to operate the indicator. If the normal fuse fails, the relay will immediately de-energize, thus making the other pair of contacts, which are fed from the stand-by fuse and also connected to the indicator. The indicator is now supplied from the stand-by fuse and remains in operation with no apparent indication of fuse failure. For a full description of the instrument, together with the principle of operation, reference should be made to A.P.1275A, Vol. 1. A routing and theoretical diagram of the installation is, however, given in fig. 4 of this group.

RUDDER AND AILERON TAB INDICATORS

13. These indicators are contained in a Type 501FL combined unit located on the cockpit port shelf just forward of the trim switch and are operated by Type 470FL Desynn transmitters, which are functioned by the tab actuators. A description of the circuit, together with the principle of operation and a routing and theoretical diagram, is contained in Group D1 of Sect. 5, Chap. 1 of this volume.

TAIL PLANE POSITION INDICATOR

14. This Type 472FL indicator is situated on the port side of the centre instrument panel, just above the machmeter, and is operated by a Type D Desynn transmitter linked with the tail plane actuator. A description of the circuit, together with a routing and theoretical diagram, is contained in Group D3 of Sect. 5, Chap. 1 of this volume.

FLAP POSITION INDICATOR

15. This Type 473FL indicator is located on the port side of the centre instrument panel, just below the machmeter, and is operated by a Type D Desynn transmitter located in the port wheel bay and connected to the flap drum switch and interconnecting levers. A description of the circuit, including a routing and theoretical diagram, is given in Group D4 of Sect. 5, Chap. 1 of this volume.

CLOCK

16. Provision is made, on the starboard side of the centre instrument panel, for the installation of a Mk. 4 clock, which is supplied and fitted by the Service.

General

18. The necessary servicing to maintain the flying instruments in an efficient condition and the Standard Serviceability Tests, which should be applied, together with the equipment to be used and the method of conducting the tests, are contained in the appropriate sections of A.P.1275A and B, Vol. 1. Before servicing or removing any of the electrically-operated instruments the aircraft must be rendered electrically safe, as described in Group A1 of Sect. 5, Chap. 1 of this volume.

PRESSURE HEAD DRAIN TRAPS

19. Drain traps are provided in the pressure head pipe-lines to collect any moisture which may enter this installation. The drain traps, which are of three different types, are connected into the installation by tee-pieces in the pressure and static pipe-lines and are located in pairs (*fig. 1*). Each type of drain trap is illustrated in the details given on *fig. 1* and the means of access to the traps is also indicated on this illustration. All the moisture, etc., in the drains should be removed periodically as follows:—

V.G. RECORDER AND ACCELEROMETER

17. Provision has been made for the installation, under the battery platform, of a Service-fitted V.G. recorder, which may be tapped into the pressure and static pipe-lines

SERVICING

- (1) The drain traps illustrated in detail F of *fig. 1* should be disconnected from the system and any moisture removed. When re-fitting the drains, new rubber sealing rings should be inserted in the union nuts and, after the nuts are tightened, an examination should be made to ensure that the unpainted ends of the drain traps do not show below the heads of the union nuts.
- (2) The drain traps illustrated in details D and E of *fig. 1* should be opened by unscrewing the slotted plugs in the wing skin until any moisture in the traps drains away.
- (3) The drain traps illustrated in detail G of *fig. 1* should be opened by inserting a suitable length and diameter of hose into each drain in turn after the removal of the small access doors. Inserting the hose pushes open the valve and allows any moisture to escape down the hose.
- (4) For the necessary servicing of the pressure head, reference should be made to A.P.1275B, Vol. 1.

of the pressure head installation (*para. 7*) after the removal of the two drain traps at frame 18. The accelerometer, which is a Mk. 2 instrument, is installed on a bracket between the gun sight mounting structure and the cabin port lighting side screen. ▶

PITOT-STATIC SYSTEM LEAK TESTS

- ◀ 20. The pitot and static systems are as leak-tight as possible and every care must be taken to maintain the system in this condition since even a moderate leak may develop into something more serious. To ensure that the leakage rate is within the required tolerances, the system must be tested in accordance with the instructions given in A.P.1275B, Vol. 2, Part 1, Leaflet A.8 whenever the system is suspect or pipeline joints and connections to instruments are disturbed. ▶

REMOVAL AND ASSEMBLY

21. The removal of the instrument panels and cockpit shelves carrying flying instruments is fully described in Group 1 of this chapter, together with an illustration showing the location of all the components. The removal of the pressure head is covered in Sect. 3, Chap. 2 of this volume, and once access has been obtained the removal of the remaining items of equipment should present no unusual difficulties.

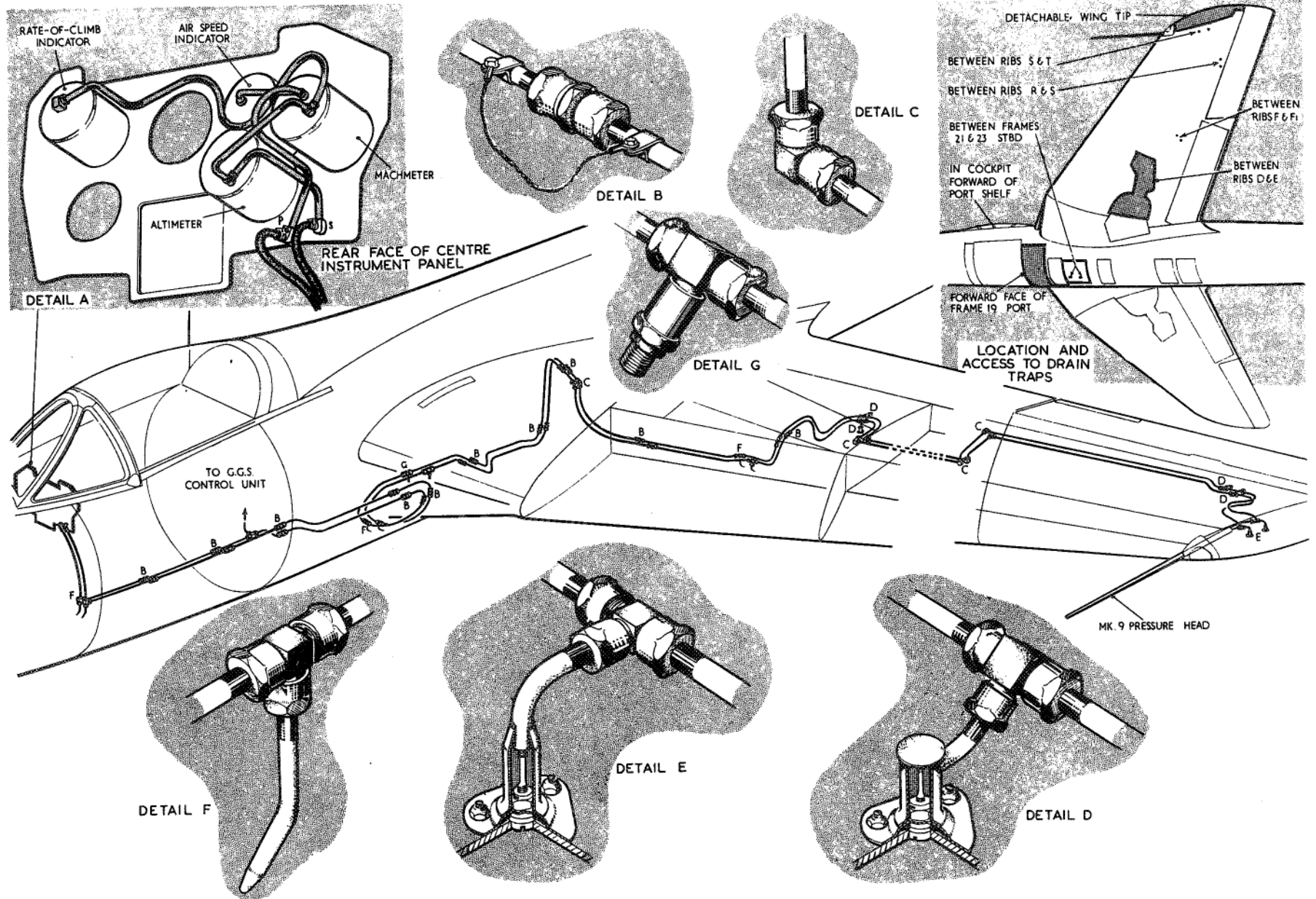

FIG. 1. PRESSURE HEAD INSTALLATION
RESTRICTED

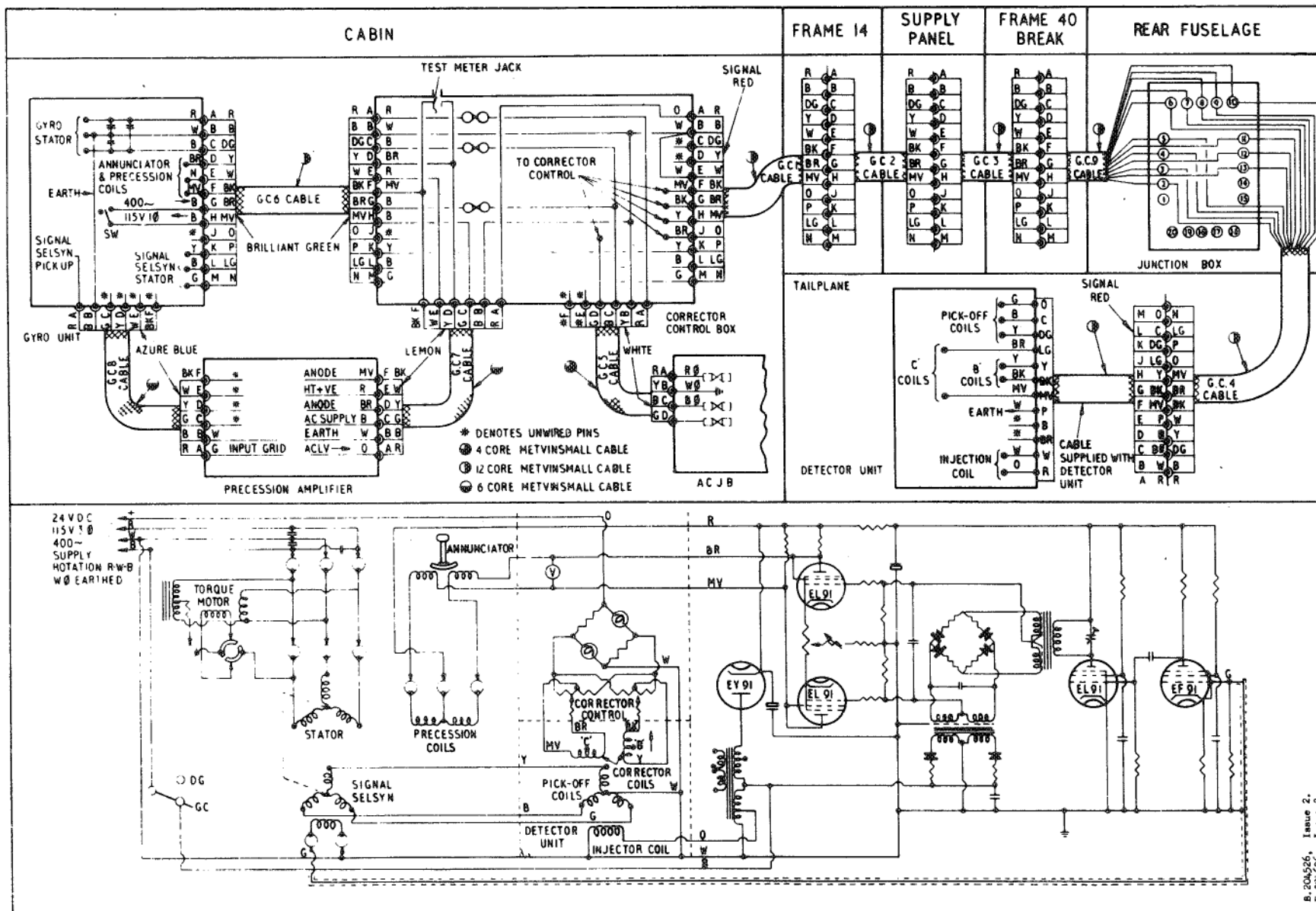

FIG. 2. GYRO COMPASS
RESTRICTED

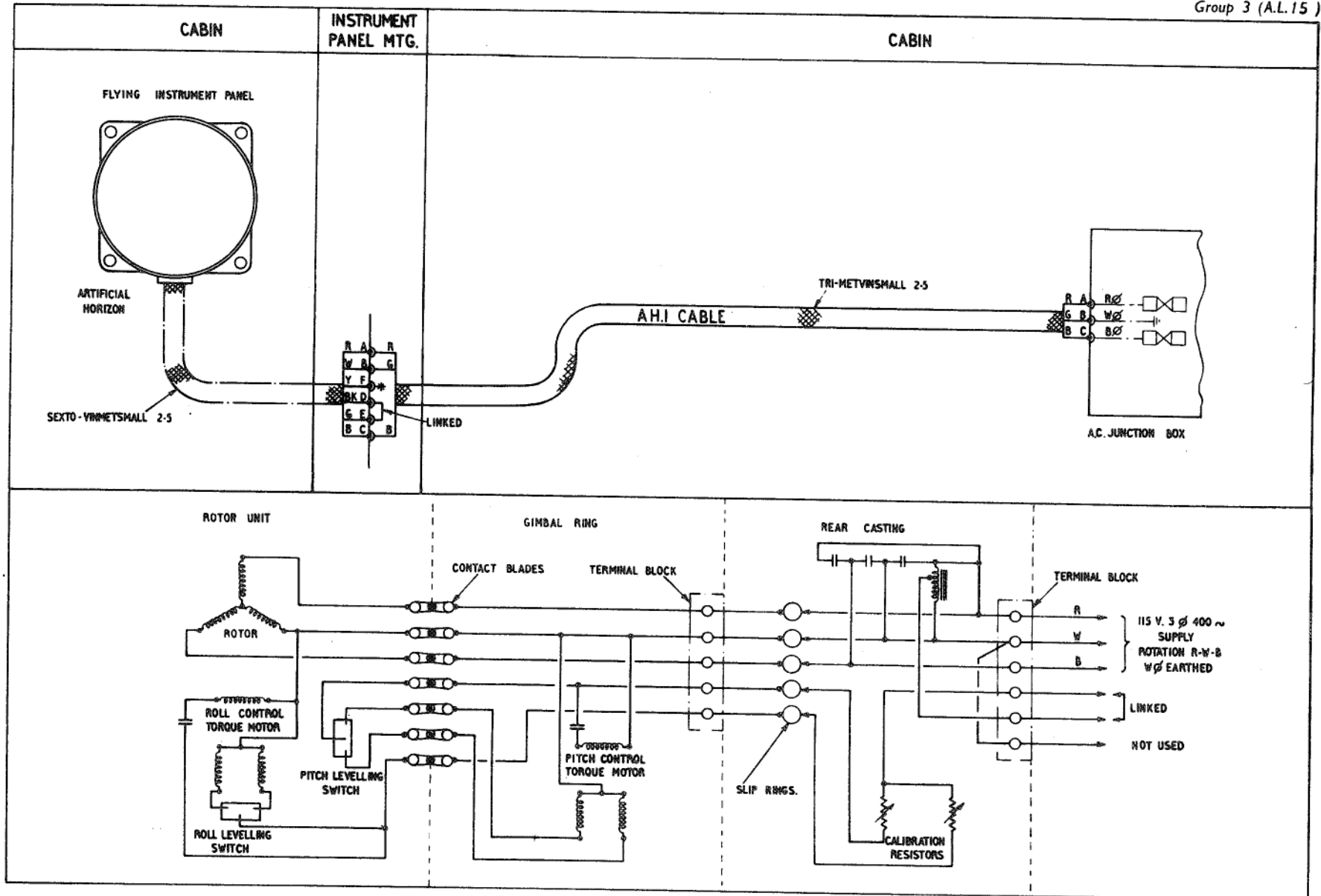
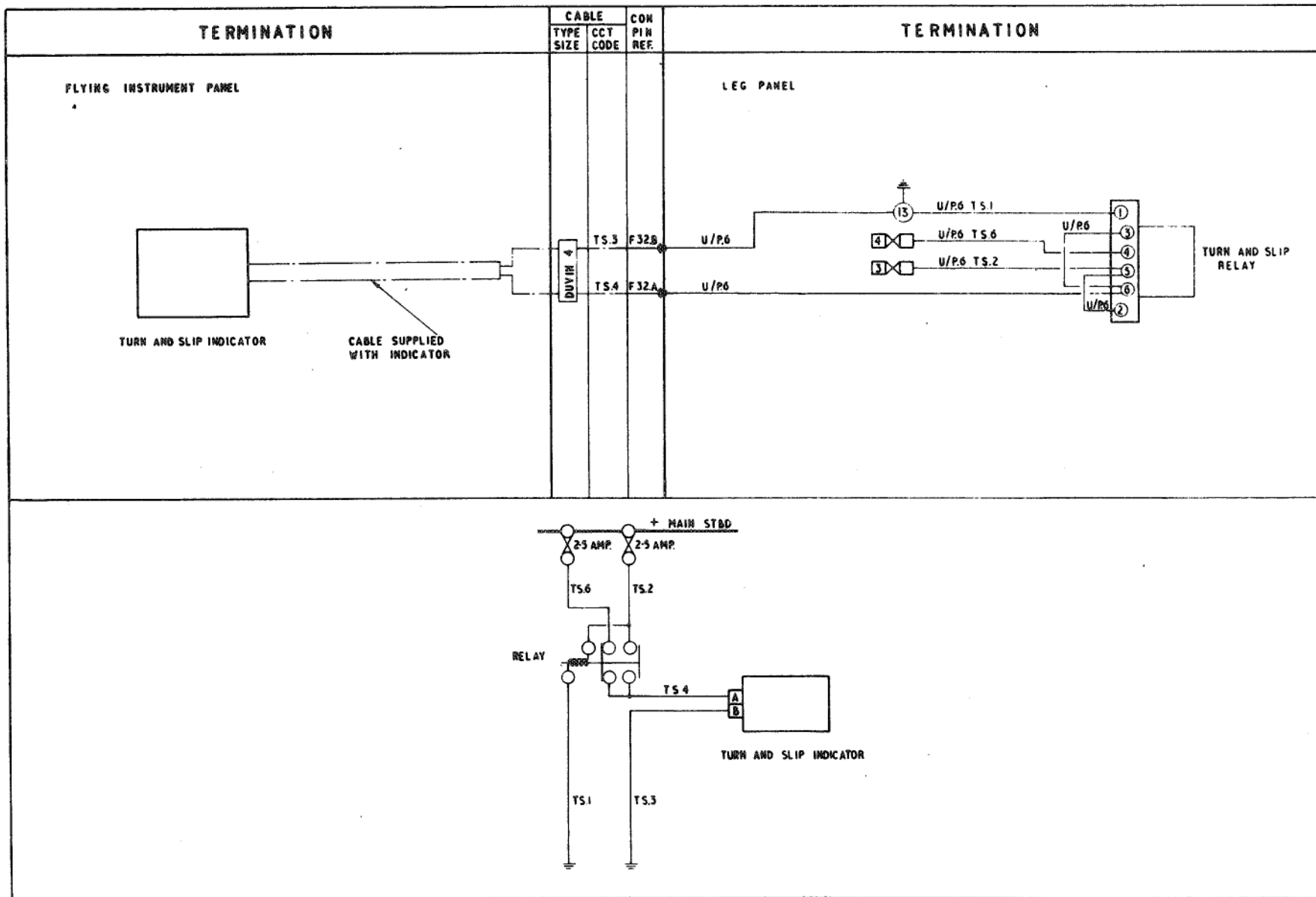

FIG. 3. ARTIFICIAL HORIZON
RESTRICTED



**FIG. 4. TURN AND SLIP INDICATOR
RESTRICTED**



This file was downloaded
from the RTFM Library.

Link: www.scottbouch.com/rtfm

Please see site for usage terms,
and more aircraft documents.