

Chapter 2 RADAR INSTALLATION

LIST OF CONTENTS

	Para.		Para.
Introduction	1	A.R.I.5849	27
DESCRIPTION		A.R.I.5131	28
General	2	A.R.I.5820	29
A.R.I.5849	3	Final check... ..	30
A.R.I.5131	5	REMOVAL AND ASSEMBLY	
A.R.I.5820	7	General	31
Inter-connection	9	Transmitter-receiver 3708, complete with junction box	32
OPERATION		Control unit, Type 909	33
General	10	Transmitter-receiver 3708, aeriels	34
A.R.I.5849	11	Receiver 3121	35
A.R.I.5131	21	Control units, Type 89 and 90	36
A.R.I.5820	23	Receiver 3121 aerial	37
SERVICING		Radar head, Type 2	38
General	24	Radar unit X.1219	39
Power supply	25	Junction box, Type 370	40
Cables and connectors	26	Inverter, Type 200	41
		Radar ballast	42

LIST OF ILLUSTRATIONS

	Fig.		Fig.
Location	1	Inter-connection (A.R.I.5131)	3
Inter-connection (A.R.I.5849)	2	Inter-connection (A.R.I.5820)	4

Introduction

1. Contained in this chapter is a description of the radar equipment installed in this aircraft, including the necessary servicing information required to maintain the installations in an efficient condition. Information on the removal of the various components, together with illustrations showing the loca-

tion and inter-connection of the equipment, are also included. For a detailed description and technical information of the standard equipment used, reference should be made to the following Air Publications:—

A.R.I.5849... ..	A.P.2914AF
A.R.I.5131... ..	A.P.2887D
A.R.I.5820... ..	A.P.2917E

DESCRIPTION

General

2. The radar equipment installed in this aircraft consists of an A.R.I.5849 (D.M.E.) navigation aid, an A.R.I.5131 (I.F.F.) installation and an A.R.I.5820 installation. The transmitter-receivers of the D.M.E. and the I.F.F. installations are carried on a radio mounting structure extending between frames 16 and 19 on the port side of the radio bay in the front fuselage (Sect. 6, Chap. 1) and employ suppressed aeriels. The radar head of the A.R.I.5820 installation is located in the nose of the aircraft, while the ranging unit is situated just forward of frame 6 in the front fuselage. All the installations are remotely operated by control units situated in the cockpit, and the location of the radar equipment is illustrated in fig. 1.

A.R.I.5849

3. This is an interrogator-responder (D.M.E.) installation which operates in conjunction with an M.G.R.I.5861 ground transponder and shows on a meter the range and heading of the aircraft with relation to the ground transponder. It is used as an aid to navigation. The installation employs a Type 3708 transmitter-receiver, complete with a Type 396 junction box, which are both clamped into a sliding S.B.A.C. mounting rack located at the forward end of the top platform of the radio mounting structure in the radio bay. The transmitter-receiver uses separate suppressed aeriels for transmission and reception. The transmitting aerial being in the engine starter access door on the underside of the centre fuselage, while the receiving aerial is in the engine access door also on the underside of the centre fuselage. The installation is remotely operated by a Type

909 control unit situated on the cockpit starboard shelf, and the range and heading meter is mounted on the starboard side instrument panel.

4. The installation operates on a choice of eight spot frequencies between 190 to 240 Mc/s. The selection of the spot frequencies is made by turning switches in the control unit, and the transmitter and receiver frequencies are selected so that the transmitter and receiver are not working at the same frequency. This arrangement reduces the possibility of errors from ground reflection. The electrical supply circuit of the installation is described in Group H1 of Sect. 5, Chap. 1 of this volume.

A.R.1.5131

5. This is an I.F.F. Mk. 3 GR installation, the basic purpose of which is to enable the aircraft automatically to identify itself as friendly when challenged by appropriately equipped air, sea and ground forces. A supplementary purpose is to enable the aircraft to serve as a beacon on which other appropriately equipped aircraft can "home". In addition, identification can be given to G.C.I. stations. The installation employs a Type R.3121 receiver, which is carried on a Type 1110 mounting rack located on the top platform of the radio mounting structure in the radio bay. The suppressed aerial is in the leading edge of the fin, near the top. The controls, which are used to pre-set the installation before flight, consist of Type 89 and 90 control units mounted together on the rear face of frame 16 above the radio mounting structure. Four separate switches, marked G, G/D, F and D respectively, are situated on the cockpit starboard shelf for remote control of the installation in flight.

General

10. For the guidance of servicing personnel a brief description of the operating procedure for the various radar installations installed in this aircraft will be found in the following paragraphs.

A.R.1.5849

11. The setting-up and operating instructions for this installation are given in detail

6. The electrical supply circuit of the installation is described in Group H1 of Sect. 5, Chap. 1 of this volume, and the installation operates in the three following frequency ranges:—

A—band 157 to 187 Mc/s.

R—band 172 to 182 Mc/s.

G—band 200 to 210 Mc/s.

A.R.1.5820

7. This is a radar ranging installation for use in conjunction with the gyro gun sight, which is described in Group 4 of Sect. 5, Chap. 2 of this volume. The ranging installation employs a Type 2 radar head and a Type X.1219 ranging unit, which are interconnected by a Type 370 junction box. The radar head is carried on a mounting structure extending forwards from frame 3 in the nose of the aircraft, while the ranging unit is located between frames 4 and 6 on a mounting structure at the top of the nose wheel bay. The junction box is bolted to the rear face of frame 3 on the starboard side below the ranging unit. The power supply for the installation is obtained from No. 2 inverter in the alternating current supplies circuit (Group E1 of Sect. 5, Chap. 1 of this volume) and from a Type 200 inverter mounted on the underside of the radio mounting structure in the radio bay. This inverter is protected from overloading by a fuse; it is carried in a fuseholder mounted in the radio bay on the forward face of the port fuel tank door on frame 19. The equipment is switched on by a switch located on the forward portion of the cockpit port shelf, and a magnetic indicator adjacent to this switch is provided to show when the installation is operating. A lamp mounted on the starboard

OPERATION

in A.P.2914AF, Vol. 1, but for those who are less concerned with the technical details the following summary is given.

12. The installation has two modes of operation, the first is searching for a transponder and the other is locked to a transponder. The first mode is indicated by the range pointer of the range and heading meter

side of the gun sight mounting structure is provided to indicate when the radar has "locked on" to a target, and a target rejection switch is located on frame 9 above the cockpit port shelf.

8. To enable the installation to be checked for correct operation, test sockets with shorting plugs and a test switch are provided. The test sockets are located on the rear face of frame 3, and the test switch is situated on the rear portion of the cockpit port shelf. The radar head, ranging unit and the Type 200 inverter are all cooled by the circulation of spent air taken from the cabin pressurization system (Sect. 3, Chap. 8) before final discharge to atmosphere. A connection, for the introduction of cooling air when ground testing the installation, is provided in the port side of the front fuselage skin. The electrical supply circuit of the installation is described in Group H1 of Sect. 5, Chap. 1 of this volume. When the radar head and ranging unit are not installed, special ballast weights (para. 42) must be fitted in lieu.

Inter-connection

9. The various components of each radar installation are inter-connected, as shown in fig. 2, 3 and 4, by a number of Contractor and Ministry of Supply connectors strapped and clipped to the aircraft structure. These connectors are of the metal-braided and non-braided type fitted with standard and miniature plug and socket type breakdown points. The Contractor's connectors are mainly employed in the supply and control circuits, while the Ministry of Supply connectors are used for the main inter-connections and aerial feed circuits.

taking 25 seconds to rise slowly from zero to 200 nautical miles, and when the full scale has been swept the pointer returns quickly to zero and a new sweep commences. When the equipment is switched to the 20-mile position, the search period is only eight seconds. The second mode of operation is indicated by the word ON showing in the window of the range and heading meter, and

RESTRICTED

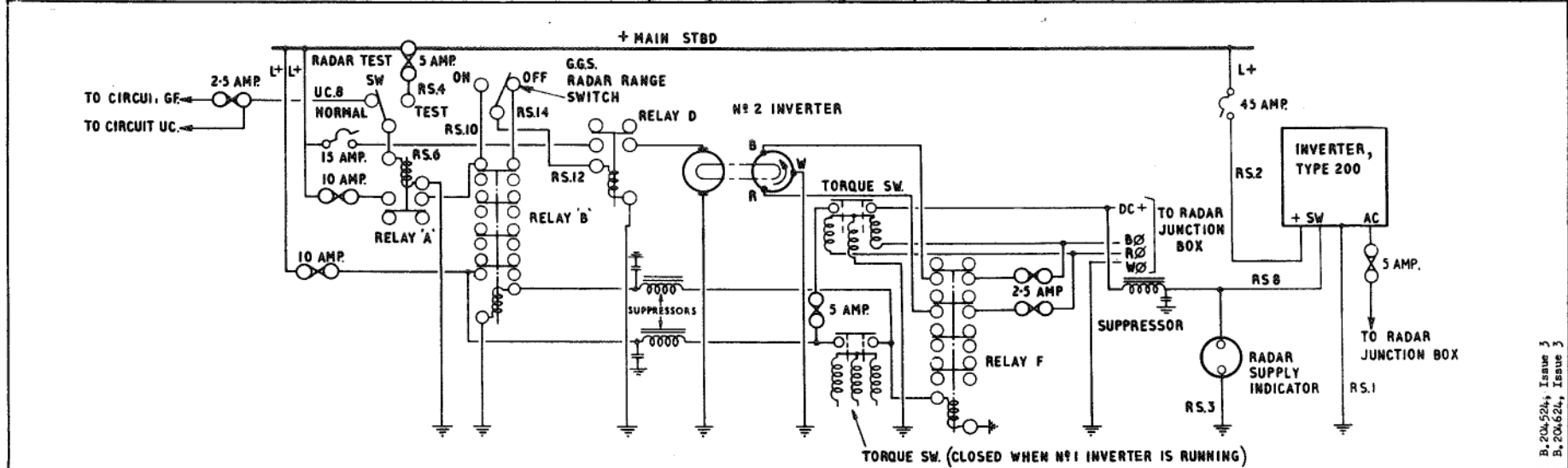
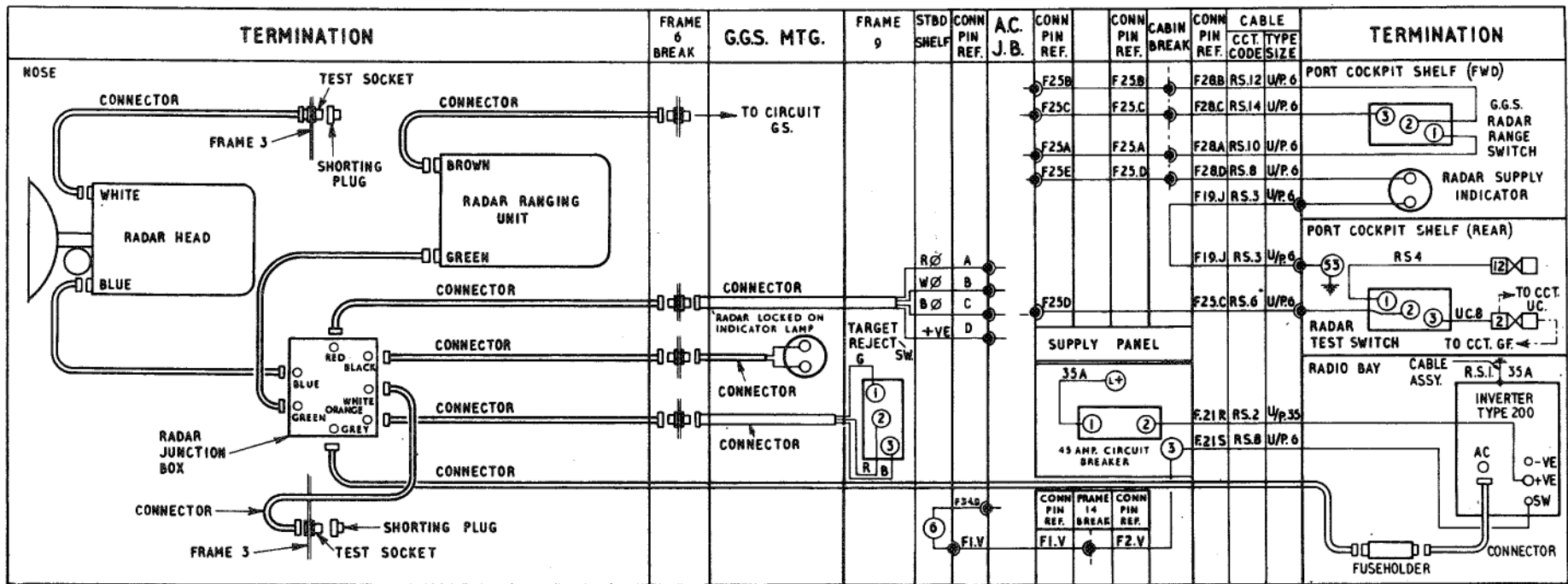

FIG. 4 INTER-CONNECTION (A.R.I. 5820)

RESTRICTED

at the same time the sweeping action of the range pointer will change to one of being locked on to the range at which interrogation takes place. After the equipment is locked on to a transponder the range shown by the meter will vary in accordance with the range variations of the aircraft from the transponder.

13. Each transponder radiates a code pulse for identification by the pilot, and if he finds that the code signal is not that of the transponder on which he means to home he can release the equipment from the locked to transponder state by depressing the strobe release push-switch on the control unit. The installation will then return to the searching condition.

14. All control of the installation is achieved by use of a Type 909 control unit situated on the cockpit starboard shelf, and the range and heading is shown on a meter located on the starboard side instrument panel. The control unit contains six separate switches as follows:—

- (1) Function and range switch—marked OFF-SB-200-20
- (2) Transmitter tuning switch—marked TX
- (3) Receiver tuning switch—marked RX
- (4) Code switch—marked CODE ON-OFF
- (5) Omni-range-homing switch—marked O/R-H
- (6) Strobe release push-switch—marked STROBE

15. The function and range switch is a four-position rotary switch, which selects the following operating conditions:—

- (1) OFF—all power switched off.
- (2) SB—standby switching; power is applied to all valve heaters, frequency changing motor circuits, aerial switching relay and the strobe lock indicator.

(3) 200—long-range operating position; searching takes place over a range of 200 nautical miles, each search sweep taking 25 seconds.

(4) 20—short-range operating position; searching takes place over a range of 20 nautical miles, each search sweep taking 8 seconds.

16. The transmitter tuning switch selects any one of eight spot interrogator channels, which are identified by the letters A to H, and the receiver tuning switch likewise selects any one of eight spot responder channels, which are identified by the numbers 1 to 8.

17. The code switch is an ON/OFF toggle switch, and when in the ON position the switch allows coding signals from the transponder to which the responder has been locked to be fed into the pilot's headset circuit.

18. The omni-range-homing switch is a two-position toggle switch. In the O/R (omni-range) position, normal ranging takes place using a special omni-directional aerial. In the H (homing) position, beam switching between the aeriels takes place, and the heading indicator shows any deviation from a true course laid on the transponder.

19. The strobe release push-switch releases the locking circuit and allows the equipment to fall back into the searching mode. The range meter will continue to search up to maximum and then fall to zero to start a new search cycle.

20. When homing, the heading pointer in the meter will show a zero reading when the aircraft is heading both towards or away from the transponder. To resolve this ambiguity, the aircraft should make a right-hand turn. If the aircraft is heading towards the transponder, the meter pointer will deviate to the left; if the aircraft is heading away from the transponder, the pointer will deviate to the right. If the aircraft makes a left-hand turn, the meter indications will be reversed.

A.R.I.5131

21. The setting-up and operating instructions for this installation are given in full detail in A.P.2887D, Vol. 1, but for those who do not require this amount of detail, the following brief summary is given.

22. The code selector switch on the control unit, Type 89, is set before flight in accordance with the orders of the day and the installation is entirely automatic in operation. Four control switches are, however, provided on the cockpit starboard shelf for switching on the equipment and for selecting the various operational facilities. These switches are as follows:—

- (1) F-SWITCH. This is a single-pole ON-OFF switch with an upright off position. It is used to switch on the installation and normal A-band operation results.
- (2) D-SWITCH. This is also a single-pole ON-OFF switch with an upright off position. It is employed in an emergency, and when placed in the ON position will give a distress signal to all stations.
- (3) G-SWITCH. This is a single-pole ON-OFF switch with a spring-return to the centre off position. It is operated only on instruction from the ground controller and alternate G and A-band operation results for 35 seconds.
- (4) GD-SWITCH. This is a single-pole change-over switch with no off position. It is employed when operating with a GCI station, and when placed in the ON position will give a distress signal to that particular station.

A.R.I.5820

23. The setting-up and operating instructions for this installation are given in full detail in A.P.2917E, Vol. 1, to which reference should be made when information is required.

SERVICING

General

24. Servicing of the radar installations is fully covered in the relevant Air Publications for the equipment concerned. Any units suspected of being unserviceable should be carefully checked in situ, and, if found to be faulty, removed from the aircraft and taken into the workshop for rectification action as necessary. The location of the radar equipment is illustrated in fig. 1, the inter-connection in fig. 2, 3 and 4, while wiring diagrams of the power supplies will be found in Group H1 of Sect. 5, Chap. 1 of this volume.

POWER SUPPLY

25. If a fault is reported in the radar installations the power supply should first be checked, in conjunction with the routing and theoretical diagrams given in Group H1 of Sect. 5, Chap. 1 of this volume, to ensure that the trouble is not located in the aircraft's electrical system. The voltage, both on and off load, must be tested and a check made to ensure that the connectors carrying the

General

31. The recommended procedure for removing the majority of the components comprising the radar installation is given in the following paragraphs. The method of assembly is, in general, the reverse of the removal sequence, but when there is any special assembly feature it is covered by a note in the appropriate paragraph. Before removing or replacing any component, the aircraft electrical system must be rendered safe, as described in Group A1 of Sect. 5, Chap. 1 of this volume.

TRANSMITTER-RECEIVER 3708, COMPLETE WITH JUNCTION BOX

32. The recommended method of removing this transmitter-receiver and junction box is as follows:—

- (1) Render the aircraft electrically safe (Sect. 5, Chap. 1, Group A1).

supply to the equipment are correctly assembled.

CABLES AND CONNECTORS

26. Servicing of the cables and connectors consists of the standard continuity and insulation resistance tests and to a periodical examination throughout their entire length for any signs of damage or deterioration of the insulation. If any signs of these defects are found, the complete cable or connector must be replaced. All the clips and straps securing the connectors to the structure must also be examined for signs of looseness and rectified as necessary to prevent chafing. All the plug and socket connections must be checked to ensure that they are fitting properly and that the fixings are screwed firmly home.

A.R.I.5849

27. For a detailed description of the servicing necessary to maintain this installation in an efficient condition, together with information on testing and fault diagnosis, reference

REMOVAL AND ASSEMBLY

- (2) Disconnect the two connectors from the transmitter-receiver and the five connectors from the junction box. Fit approved caps and covers to the plugs and sockets and stow the connectors clear of the units.
- (3) Remove the two pip-pins from the mounting channels and, using the handle on the transmitter-receiver, withdraw the transmitter-receiver, junction box and mounting rack carefully along the mounting channels until clear of the fixed mounting structure. Remove the assembly from the aircraft.
- (4) If required, the transmitter-receiver may be removed without disturbing the junction box and mounting rack. The method is as follows:—
- (5) Disengage the two connectors from the transmitter-receiver and disconnect the two locking devices securing the set to the mounting rack.

should be made to A.P.2914AF, Vol. 1. The test sets to be used and the ancillary equipment required are also quoted in this publication.

A.R.I.5131

28. A detailed description of the servicing necessary to maintain this installation in an efficient condition, together with information on testing and fault diagnosis, will be found in A.P.2887D, Vol. 1. The necessary test sets and ancillary equipment are also quoted in this publication.

A.R.I.5820

29. The necessary servicing information for this installation is contained in A.P.2917E, Vol. 1, together with the test sets and ancillary equipment required.

FINAL CHECK

30. After servicing the radar installations, ensure that the equipment is left switched off and that all access doors and panels, removed to gain access, are correctly replaced and secured.

- (6) Using the handle on the transmitter-receiver, pull the set inboard sharply in order to disengage the junction box connecting plug and, still using the handle, carefully withdraw the set from the mounting rack and remove it from the aircraft.

CONTROL UNIT, TYPE 909

33. The recommended procedure for removing this unit is as follows:—

- (1) Render the aircraft electrically safe (Sect. 5, Chap. 1, Group A1).
- (2) Remove the four screws securing the control unit mounting frame to the cockpit starboard shelf.
- (3) Raise the control unit and mounting frame to gain access to the plug and socket connection. Disconnect this connection and fit approved caps and covers to the plug and socket.

RESTRICTED

- (4) The control unit and mounting frame may now be removed from the aircraft. To remove the control unit from the mounting frame it is only necessary to remove the four screws attaching the unit to the frame.

TRANSMITTER-RECEIVER 3708 AERIALS

34. These aerials cannot be readily removed, being integral with the engine starter and engine access doors. If an aerial is found to be faulty, it is recommended that the access door containing the affected aerial is removed from the aircraft and replaced with a new door complete with serviceable aerial.

RECEIVER 3121

35. To remove this receiver, proceed as follows:—

- (1) Render the aircraft electrically safe (Sect. 5, Chap. 1, Group A1).
- (2) Disconnect the five connectors from the receiver and fit approved caps and covers to the plugs and sockets. Stow the connectors clear of the set.
- (3) Unscrew and disengage the two knurled catches securing the receiver to the mounting rack and pull the receiver inboard to release the two retaining spigots at the rear of the receiver.
- (4) Remove the receiver from the aircraft.

CONTROL UNITS, TYPE 89 AND 90

36. The recommended procedure for removing these control units is as follows:—

- (1) Render the aircraft electrically safe (Sect. 5, Chap. 1, Group A1).
- (2) Disconnect the connector from the Type 89 control unit and the three connectors from the Type 90 control unit. Fit approved caps and covers to the plugs and sockets and stow the connectors clear of the control units.
- (3) Remove the four bolts securing the Type 90 control unit and its mounting bracket to frame 16 and remove the

bracket, complete with control unit, from the aircraft, taking care to retain the four washers.

- (4) Remove the two bolts securing the Type 89 control unit and its mounting bracket to frame 16 and remove the bracket, complete with control unit, from the aircraft, taking care to retain the two washers.
- (5) To remove the control units from their mounting brackets it is only necessary to remove the screws passing through the brackets and into the back plates of the control units, taking care to retain the spring washers. The Type 89 control unit is secured by two screws, while the Type 90 unit is retained by three screws.

Note . . .

On re-assembly of the mounting brackets and control units to frame 16, ensure that the bonding wires from the pressurization pipes are replaced under the heads of the top fixing bolts.

RECEIVER 3121 AERIAL

37. The recommended method of removing this aerial is as follows:—

- (1) Render the aircraft electrically safe (Sect. 5, Chap. 1, Group A1).
- (2) Remove the aerial access door from the leading edge of the fin.
- (3) Remove the nut and bolt securing the lower end of the aerial blade to the insulator bracket.
- (4) Remove the nut from the Type 145 adapter mounted on the fin rear spar extension and disconnect the aerial matching stub.
- (5) Disengage the aerial blade from the adapter and remove it from the aircraft.

RADAR HEAD, TYPE 2

38. The recommended method of removing this component is as follows:—

- (1) Render the aircraft electrically safe (Sect. 5, Chap. 1, Group A1).

- (2) Gain access to the radar head by removing the fuselage nose piece (Sect. 3, Chap. 1).
- (3) Disconnect the two connectors at the radar head. Fit approved caps and covers to the plugs and sockets and stow the connectors clear of the unit.
- (4) Disconnect the cooling air pipe from the port side of the radar head. Mask off the end of the air pipe and the entry into the radar head to prevent the entry of foreign matter.
- (5) Disengage the two catch assemblies retaining the radar head in its mounting rails and remove the component from the aircraft by carefully withdrawing it forward along the rails until it is clear of the structure.

RADAR UNIT X.1210

39. The recommended procedure for removing this unit is as follows:—

- (1) Render the aircraft electrically safe (Sect. 5, Chap. 1, Group A1).
- (2) Gain access to the nose wheel bay and disconnect the two connectors from the forward end of the radar unit. Fit approved caps and covers to the plugs and sockets and stow the connectors clear of the unit.
- (3) Disconnect the cooling air pipe from the port side of the radar unit. Mask off the end of the air pipe and the entry into the radar unit to prevent the entry of foreign matter.
- (4) Taking the weight of the radar unit, withdraw the spring-loaded catch pins securing the mounting tray to the mounting beam. Still supporting the tray and radar unit, allow them to swing down, under control, to their full extent.
- (5) To remove the radar unit from its mounting tray, support the unit and disengage the two catch assemblies retaining it in the tray. Carefully withdraw the unit from the tray and remove it from the aircraft.

JUNCTION BOX, TYPE 370

40. The recommended procedure for re-removing this junction box is as follows:—

- (1) Render the aircraft electrically safe (*Sect. 5, Chap. 1, Group A1*).
- (2) Gain access to the nose wheel bay and disconnect the seven connectors from the junction box. Fit approved caps and covers to the plugs and sockets and stow the connectors clear of the junction box.
- (3) The junction box may now be removed from the structure by removing the four bolts securing it to the rear face of

frame 3, taking care to retain the washers.

INVERTER, TYPE 200

41. The recommended method of removing this component is covered in the removal of the gun firing panel, as described in *Sect. 5, Chap. 1, Group A2* of this volume.

RADAR BALLAST

42. Ballast weights (*Stores Ref. 26FX/3963 and 26FX/3964*), representing the ranging unit and radar head respectively, are supplied to special order only (*Mod. H.21*) for fitment when this radar equipment is not

installed. These weights incorporate stowage points for the electrical cables and cooling air pipes and are carried on the mounting structure normally used by the radar equipment. The assembly of the weights is similar to that for the radar equipment, which is a reversal of the removal instructions given in *para. 38 and 39* of this chapter, with the exception that the retaining catches, which normally engage with the radar equipment, should in the case of the ballast weights pass through the holes in the forward plates of each weight and engage with the chamfered portion at the lower edge of each hole.

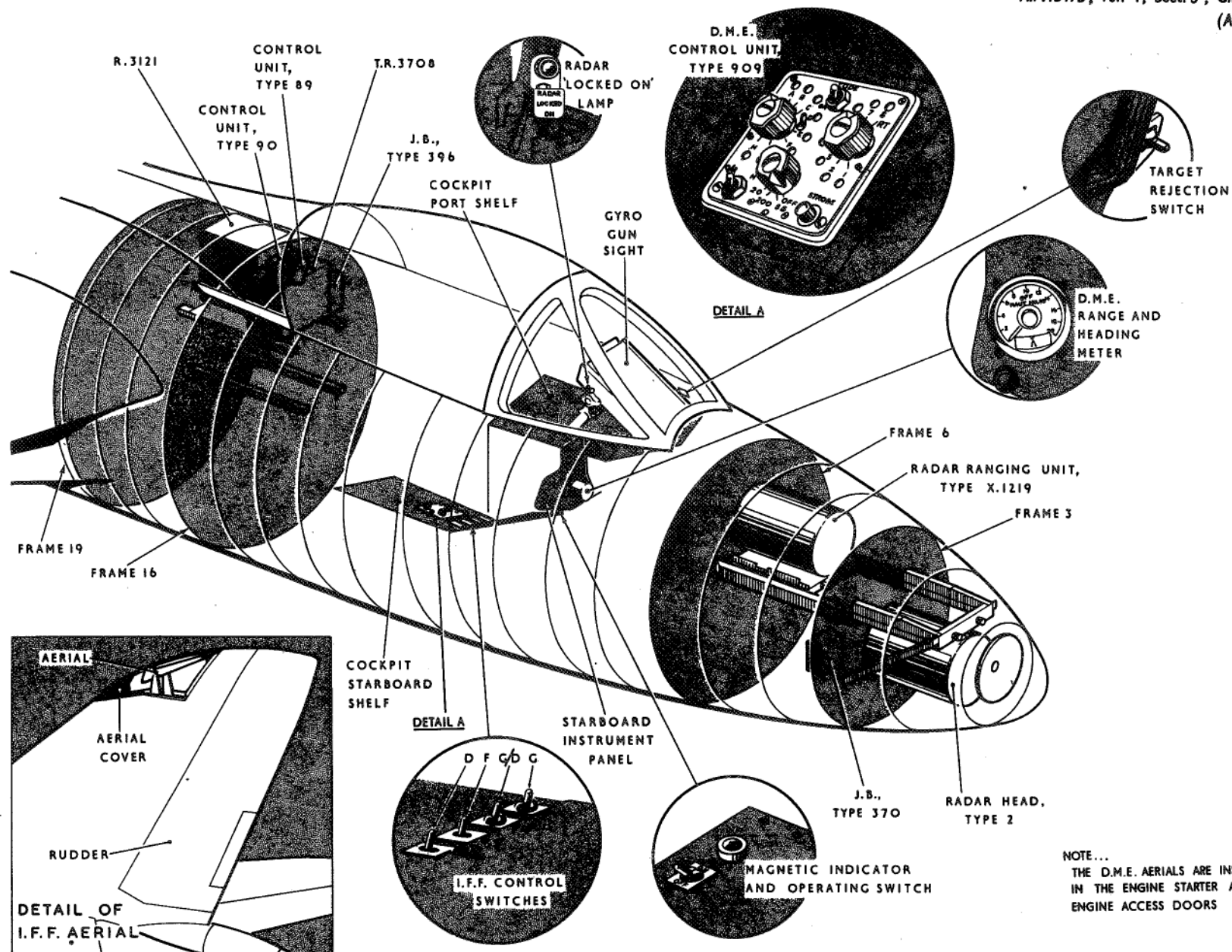

NOTE...
THE D.M.E. AERIALS ARE INSTALLED
IN THE ENGINE STARTER AND
ENGINE ACCESS DOORS

FIG. 1. LOCATION
RESTRICTED

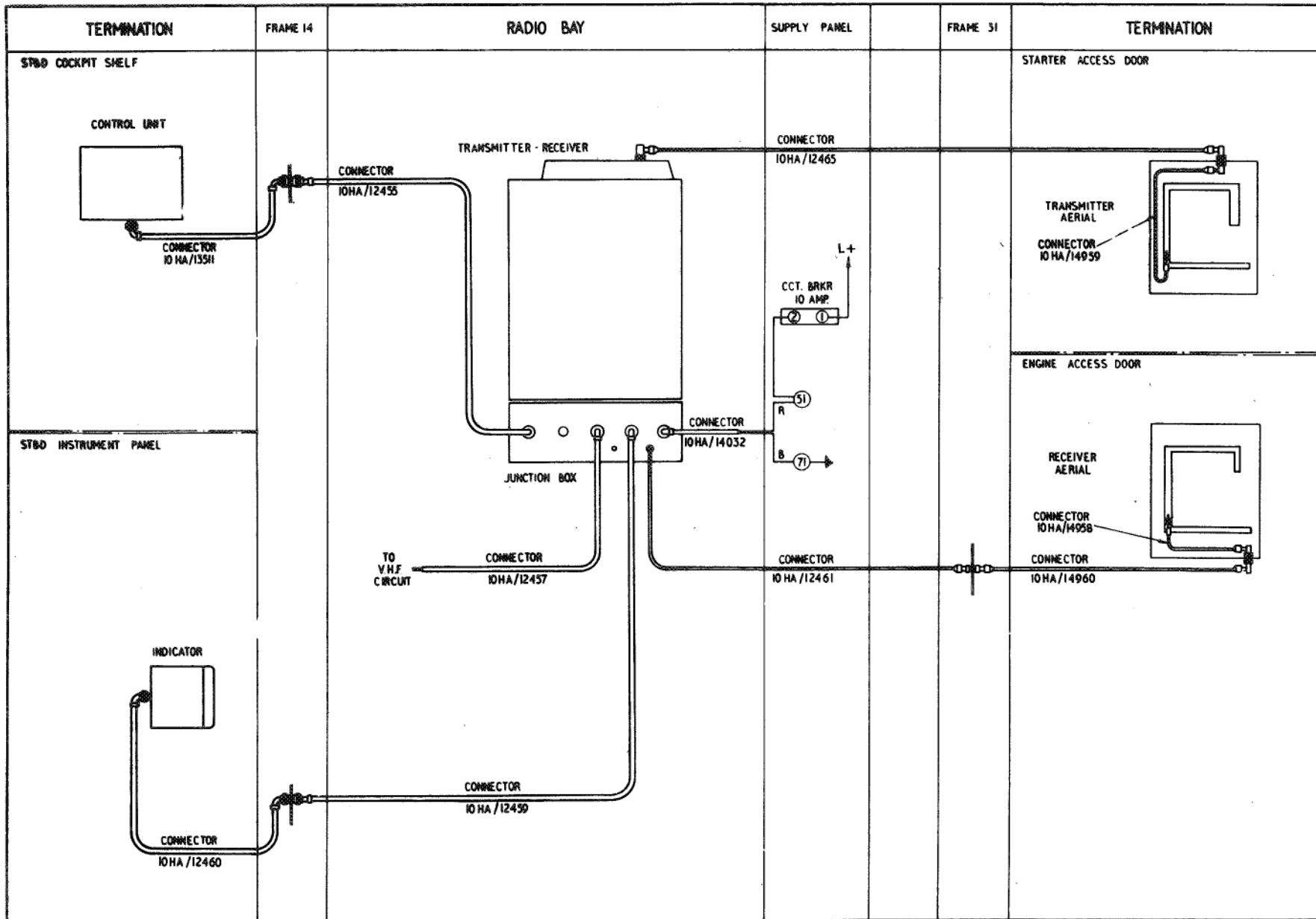

FIG. 2. INTER-CONNECTION (A.R.I.5849)

RESTRICTED

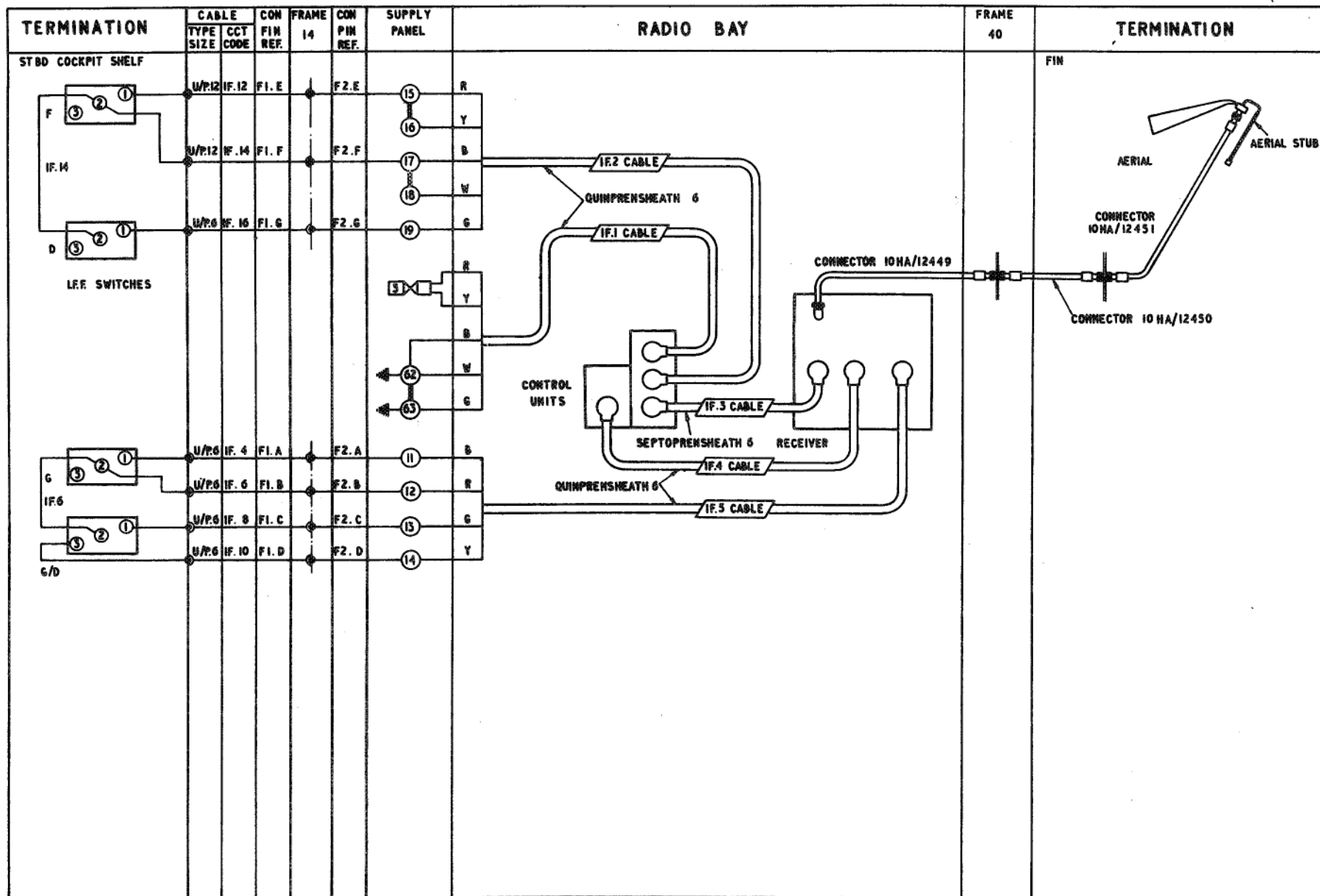

FIG. 3. INTER-CONNECTION (A.R.I.5131)

RESTRICTED

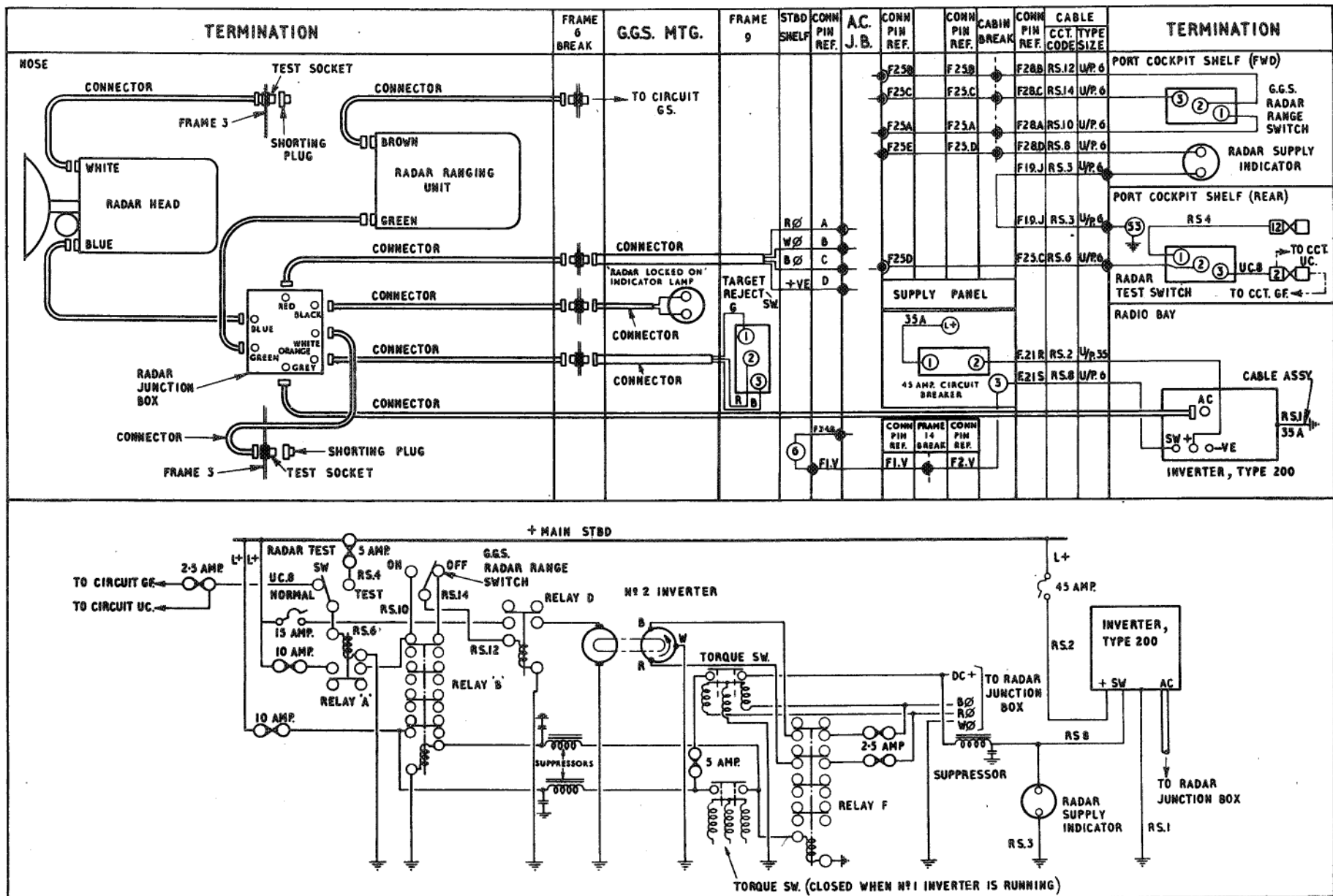

FIG. 4 INTER-CONNECTION (A.R.I. 5820)

RESTRICTED

This file was downloaded
from the RTFM Library.

Link: www.scottbouch.com/rtfm

Please see site for usage terms,
and more aircraft documents.

