

CHAPTER 2 PREPARATION FOR FLIGHT

LIST OF CONTENTS

	<u>Para.</u>		<u>Para.</u>
Introduction	1	Engine	
Refuelling	2	Refilling oil sump	16
Defuelling	4	Refilling accessories gear box and turret. ..	17
Draining water from fuel system	5	Refilling fuel filter de-icing tank	18
Refilling hydraulic reservoir	6	Priming the fuel system	19
Charging hydraulic emergency and anti-G, air bottles	7	Running the engine	
Charging hydraulic accumulators		Precautions prior to running the engine... ..	21
Wheel brakes	8	Starting preliminaries	23
Aileron assister	9	Starting... ..	24
Elevator assister	10	Running up engine with batteries removed . .	25
Charging oxygen cylinders	11	Main undercarriage deflection check	26
Changing batteries	12	Nose undercarriage deflection check	27
Refilling de-icing tank (Deleted by Mod.581)... ..	13	Checking tyre pressures	28
Topping - up liquid starter fuel tank	14	Air Drier	29
Topping - up cold air unit.. ..	15	Removal of locking devices and covers	30
		Fitting drop tanks	31

LIST OF ILLUSTRATIONS

	<u>Fig.</u>
Servicing points	1
Nose undercarriage shock-absorber extension.	2 *
Fitting drop tank	3
Jettison and reset mechanism	4

* To be issued later

WARNING

An aircrew ejection seat is fitted to this aircraft. Before attempting to enter the cabin, therefore, ensure that the instructions given in the Ejection Seat Warning, following the Introduction at the beginning of this volume, have been carried out. In the interests of safety, this is very important.

Introduction

1. This chapter describes the refilling and charging of the various systems and the preparation of the aircraft for flight, the location of the various servicing points being given in Fig.1. When the necessary operations are completed a check must always be made to ensure that all tools have been removed and that all panels and access doors lie

H.A.L.8.

RESTRICTED

flush with the surrounding surface and are securely fastened. The access doors and panels are shown in Sect.2, Chapter 4, Fig.2. The operations described below are grouped for convenience under their various systems and do not, therefore, constitute the order in which the operations are to be carried out. For details of the sequence to be followed, reference should be made to the Servicing Schedules.

REFUELLING

2. The aircraft is refuelled under pressure through a $1\frac{1}{2}$ in. standard coupling in the port wheel bay (fig.1, item 12). High pressure bowser, which are capable of refuelling the aircraft at a rate of 150 gallons per minute at a pressure of 45-50 lb. per sq.in., should be used, but if these are not available, existing bowser may be used with an adaptor hose.

3. The disposition of the tanks, their interconnections and diagrams of the fuel system are given in Section 4, Chapter 2 of this handbook. The procedure for refuelling the system is as follows:-

- (1) Earth the bowser to the aircraft structure.
- (2) Ensure that the defuelling cock (fig.1, item 17) accessible via the engine starter access door, in the bottom of the fuselage, is turned OFF. (This is important)
- (3) Ensure that the L.P. fuel cock in the cabin is OFF.
- (4) Ensure that the ganged cocks at the bottom of the rear transport joint are ON. (If the transport butt strap is in position, the cocks will already be ON).

- (5) Remove the sealing cap from the refuelling coupling in the port wheel bay and connect up the bowser hose in its place.

NOTE...

Ensure that the refuelling pressure relief valves in the underside of the stub wings are free to operate. This is particularly important when icy conditions prevail (Sect.4, Chap.2).

- (6) Start the bowser pump and set the bowser control to RE-FUEL.
- (7) Set the battery master on the leg panel in the cabin to ON and the time switch in the port wheel bay to ON. (The refuelling indicator lights in the wheel bay, one for each refuelling valve, should then come on). If a low-pressure bowser is being employed, refuelling may take longer than 8 minutes and this will necessitate switching on the time switch for a second cycle. The servo valves in the aircraft fuel system will automatically close when the tanks are full and the refuelling circuit will cease to operate.

NOTE...

During refuelling, ensure that, after 50-100 gallons of fuel has passed into the aircraft, air is passing out of the refuelling pressure relief valves. This is particularly important when icy conditions prevail.

- (8) When refuelling is completed, the refuelling indicator lights will go out. Check the contents of the fuel tanks by means of the

fuel gauges in the cabin.

(9) Remove the refuelling equipment and replace the sealing cap on the refuelling coupling in the port wheel bay. Switch off time switch if it has not completed its full cycle.

DEFUELLING

NOTE...

Before defuelling is commenced, the defuelling cock (fig.1, item 17) must be turned to the 'ON' position. The defuelling cock is accessible via the engine starter access door in the bottom of the fuselage aft of the main spar.

4. The aircraft is defuelled through the refuelling coupling in the port wheel bay. The fuel is drained via the front tanks, being either sucked out by a bowser or pumped out by the tank booster pumps. An air supply is required to transfer the fuel from the rear, wing and drop tanks to the front tanks during defuelling. The air supply, which must not exceed 120 lb. per sq.in. is fed into the system through an external supply connection accessible via an access panel in the spine of the centre fuselage (fig.1, item 7). The procedure for defuelling the aircraft is as follows:-

- (1) Earth the bowser to the aircraft structure.
- (2) Remove the sealing cap from the refuelling coupling in the port wheel bay and connect the bowser hose in its place.
- (3) Connect an external air supply to the external air pressurisation connection in the spine of the centre fuselage (fig.1, item 7) and apply a pressure not exceeding 120 lb. per sq.in. (Generally the cabin pressurisation test rig

is used for this purpose, after it has been set to 10 lb. per sq.in. pressure.

- (4) Set the bowser control to DEFUEL.
- (5) Turn the L.P. cock to OFF and the selector cocks to 'auto'.
- (6) Turn the defuelling cock (fig.1, item 17) to ON (accessible via the engine starter access door in the bottom of the fuselage).
- (7) Start the bowser pump to draw out fuel.
- (8) When the tanks are empty, turn the defuelling cock to OFF immediately and re-lock with stainless steel wire (Stores Ref.30A/2514 to Spec.DTD.189) to ensure that it remains closed. (This is important).
- (9) Disconnect the defuelling equipment, re-fit the sealing cap on the refuelling coupling in the port wheel bay and the cap and access door of the air pressurisation connection in the spine member.

DRAINING WATER FROM THE FUEL SYSTEM

5. To facilitate the drainage of any water that may accumulate in the fuel system, six small drain valves are provided at the lowest points of the fuel system together with a small plug in the engine fuel filter casing. These must be used daily to drain off a few pints of fuel and any water that may have accumulated. The position of these valves are indicated in fig.1 items 16, 18 & 27. To use the valves, remove the sealing caps and insert a suitable length and diameter of hose into each valve in turn. Inserting the hose pushes open a spring loaded valve. When drainage of water is complete, remove the hose, replace the sealing caps and secure the access doors.

REFILLING HYDRAULIC RESERVOIR

NOTE...

Hydraulic fluid has a detrimental effect on paint, electrical cables, rubber etc. and although a drip tray is provided, great care must be taken to ensure that no fluid is spilled on such parts.

6. Access to the filler neck of the hydraulic reservoir is obtained by removing an access door from the top surface of the starboard wing fillet (fig.1, item 5). The filler neck is provided with a sight glass to facilitate checking the level. If, with the aircraft standing on its alighting gear with the hydraulic accumulators inflated and fully charged and the landing flaps and air brake up, the level no longer overlaps the white background below the sight glass, the reservoir must be topped up. To top up, remove the filler cap slowly to release any built up pressure and pour in fluid until it reaches the white background. A container, fitted with a flexible nozzle, should be used to facilitate the operation. When refilling is complete, replace the filler cap securely and mop up any spilled fluid.

CHARGING HYDRAULIC EMERGENCY AND ANTI-G, AIR BOTTLES

7. The two high-pressure air bottles for the emergency operation of the alighting gear and flaps are mounted together in the front fuselage just behind the pilot's seat. The two anti-G air bottles are installed above them. It is essential to ensure that these air bottles are fully charged before each flight. Three pressure gauges are provided to check the pressure in the bottles. The hydraulic emergency air bottle gauges are situated in the cabin at the aft end of the cabin port shelf. The anti-G bottle gauge is situated on the starboard side of

AND
ASSOCIATED
PRESSURE
GAUGE

the cabin between frames 10 and 11 above the cabin shelf. If the pressure is below that indicated in the Leading Particulars, the bottles must be re-charged. An in-situ charging valve, located on the port side of the battery mounting platform and accessible via the radio access door (fig.1, item 21), is provided for the purpose. All four bottles are charged simultaneously through the one valve.

NOTE...

If either emergency has been used, it is necessary to re-set the air release valves, bleed and re-prime the hydraulic system (Section 3, Chapter 6). The air bottles must then be recharged.

CHARGING HYDRAULIC ACCUMULATORS

WHEEL BRAKES

8. Access to the wheel brakes hydraulic accumulators and their charging connection is from within the nose wheel bay, port side. The pressure in the accumulators is indicated on the brake accumulator pressure gauge on the rear of the cabin port shelf. If the air pressure shown on the gauge is below that quoted in the Leading Particulars, after dissipating the hydraulic pressure by operating the brakes until they cease to operate, the accumulator must be recharged through the charging connection in the wheel bay (fig.1, item 23).

AILERON ASSISTERS

9. Access to the hydraulic accumulator for the aileron assister, together with its charging connection, may be obtained from within the starboard wheel bay. After dissipating the hydraulic pressure by operating the controls a number of times until

RESTRICTED

they cease to operate, the air pressure should be checked by ~~connecting a pressure gauge to the charging connection~~ and if below that quoted in the Leading Particulars, the accumulator must be recharged (Fig.1, item 2).

NOTE...

When pressure is dissipated prior to recharging, the power control for the ailerons is automatically disengaged and, therefore, it is important to ensure that the pawls of the hydro-booster jacks are re-engaged before flight by holding the aileron and operating the control column, while using the hand-pump (fig.1, item 11).

ELEVATOR ASSISTER

10. Access to the hydraulic accumulator and its charging connection may be obtained by removing an access door in the port side of the dorsal fin just forward of the tail plane. The access door is provided with a window to enable the accumulator pressure to be checked by reference to a pressure gauge located adjacent to the accumulator. If, after dissipating the hydraulic pressure by operating the controls a number of times until they cease to operate, the air pressure shown on the gauge is below that quoted in the Leading Particulars, the accumulator must be recharged after removing the access door (fig.1, item 6).

NOTE...

When pressure is dissipated prior to recharging the accumulator, the elevator power control will be automatically disengaged and, therefore it is important to ensure that the pawls of the hydro-booster jack are re-engaged correctly before flight by holding the elevator and operating the control column, while using the handpump.

Charging oxygen cylinders

11. The two oxygen cylinders are mounted in the nose of the aircraft between Frames 4, 5 and 6 on the starboard side of the aircraft, the in-situ charging valve Mk.8, ^{or MK10} being mounted below them on the forward face of Frame 6, (Fig.1, item 24). Access to both the cylinders and charging valve can be obtained from within the nose wheel bay. The cylinders may be re-charged in-situ to the pressure quoted in the Leading Particulars, through the valve, or the cylinders may be replaced by fully charged cylinders as described in Section 3, Chapter 10 of this handbook. The procedure for in-situ charging is described in A.P.1275A, Vol.1, Section 8, Chapter 3.

NOTE...

It is essential in the interests of safety, that oxygen installations are kept free from oil, grease or moisture and for this reason covers are fitted over the cylinder valves and charging valve. The charging valve cover must be removed before the system can be recharged.

Changing batteries

12. The two 12 volt batteries are carried on a platform mounted at the bottom of the radio bay in the front fuselage. Access may be obtained via the radio access doors (fig.1, item 20) and the procedure for changing the batteries is as follows:-

- (1) Ensure that the battery isolating switch, mounted on the leg panel in the cabin is set to the OFF position.
- (2) Disengage the battery cover retaining strap from the mounting platform and remove the cover.

RESTRICTED

- (3) Disconnect the battery leads and stow them on the dummy terminals on the mounting platform.
- (4) Unscrew the four wing nuts, located above the platform, disconnect the hinged wire straps on the batteries from the locking plates and carefully remove the batteries.
- (5) Place a new set of batteries on the platform and reverse the procedure in sub-para. (2) to (4).

Refilling de-icing tank

~~13. The de-icing tank is mounted between frames 4 and 5 (Fig.1, item 22), access being obtained by removing a small access panel in the port side of the nose of the aircraft. The tank should be filled up to the level of the filler cap with de-icing fluid to the specification quoted in the Leading Particulars.~~

Topping-up liquid starter fuel tank

14. The filler for the liquid starter fuel tank is accessible via a small access panel in the top port side of the centre fuselage, just aft of the main spar (Fig.1, item 3). The dipstick is marked for four starts (approx. $\frac{1}{2}$ gall. per start). The tank should be topped up to the upper start mark on the dipstick. Care should be taken to ensure that no liquid is spilled as it is detrimental to electric cables etc.

Topping-up cold air unit.

15. An access door in the top starboard side of the centre fuselage (Fig.1, item 4), between frames 27 and 28 gives access to the cold air unit dipstick and filler orifice. The oil level in the unit should be examined daily and topped-up as necessary with oil as quoted in the Leading Particulars until

it reaches the full mark on the dipstick. The oil should be poured through the dipstick orifice in small quantities, otherwise a false level will be indicated on the dipstick.

ENGINE

Refilling oil sump

16. The engine oil sump is filled under pressure via a self sealing connection which is accessible through the main engine access door (Fig.1, item 8). The sump is provided with a sight glass to indicate the oil level. If level is low as indicated by the sight glass, oil should be pumped into the sump via the self-sealing connection until level is correct. The type of oil to be used is quoted in the Leading Particulars.

NOTE...

It is not necessary to prime the oil system, although it is advisable to turn the engine over to ensure oil circulation and pressure indication before running the engine. After the initial ground run, the level should be re-checked and the sump replenished if necessary.

Refilling accessories gearbox and turret

17. The accessories gear-box, and the turret incorporated in the drive assembly, are each provided with a filler and dipstick. Access to the gearbox filler is via an access door on the underside of the fuselage forward of the rear spar (Fig.1, item 13) and that of the turret via a larger door situated just aft of the rear spar (Fig.1, item 10). Prior to checking the level, ensure that the dipstick of each unit is pressed right home before removing. If level is low as indicated by the dipstick, replenish until the oil is level with the overflow

pipe. The specification of the oil for topping up both units is given in the Leading Particulars.

Refilling fuel filter de-icing tank

18. The fuel system filter de-icing tank is mounted in the engine bay. The tank is filled via two self-sealing couplings mounted adjacent to the bottom access door (fig.1, item14) forward of the rear spar in the centre fuselage. Alcohol is pumped from a ground supply to the aircraft tank. During the process of filling, the displaced air returns to the supply tank via a pipe which contains a sight glass. When alcohol is seen in the sight glass, the aircraft tank is full.

Priming the fuel system

19. Priming consists of bleeding the fuel pumps and the system generally to remove all air or oil, if the engine has been inhibited. Bleeding must always be carried out if the engine is newly installed, whenever it has been inhibited or when there has been any disconnection in the system at any point, or the fuel tanks have been drained.

NOTE...

The high pressure pumps are fuel lubricated, consequently they will suffer damage if the engine is turned over when the pumps are dry. It is essential, therefore, to ensure that the engine is not turned before the system is primed.

20. The system should be bled at each point, working upwards from the lowest bleed point. The procedure is described in the engine handbook.

NOTE...

To obviate the risk of fire when starting the engine, remove any fuel that may have been spilled.

It may be necessary to bleed the system again if fluctuations of R.P.M. are experienced on the initial ground run after bleeding. This fluctuation may be due to trapped air having moved round into the pumps under running conditions.

Running the engine

WARNING

Before attempting to start the engine, ensure that all personnel are at a safe distance from the air intakes and jet exhaust and take the necessary action to prevent any person walking into these danger zones.

Precautions prior to running the engine

21. Before running an engine which has been newly installed, or which has been inhibited or an engine in which there has been any disturbance of the components of the fuel system, such as disconnected pipes, draining etc., the fuel system must be primed as described in para.19 and 20.

22. Remove the air intake, jet pipe sealing and centre fuselage covers and examine the engine to ensure that the air intake ducts and engine are free from accumulations of fuel or oil and that no cleaning cloths or tools have been left around the engine. The air intake safety guards must be fitted prior to ground running the engine.

Starting preliminaries

23. Prior to starting the engine, the aircraft should be headed into wind with the tail pointing away from other aircraft and all three wheels of the alighting gear effectively chocked.

NOTE...

If the aircraft is standing on concrete, do not use metal clad chocks. Ensure that at least

one member of the ground crew is standing by with a Pyrene type fire extinguisher (not foam). It should be noted that the cabin pressurization system must not be turned on before starting the engine.

Starting

24. The engine is started by means of a Plessey Iso Propyl Nitrate Liquid Fuel Starter. A description of the starter is given in Sect.5, Chap.1. For a description of engine starting procedure, reference should be made to the engine handbook.

Running up engine with batteries removed

25. If the engine is run up with the batteries removed, care must be taken to ensure that the bared ends of the battery leads are stowed on the dummy terminals provided on the battery mounting platform.

Main undercarriage deflection check

"26. The main undercarriage legs must be checked in accordance with the instructions given in Sect.3, Chap.5, fig.14 and re-charged as necessary."

Nose undercarriage deflection check

27. (To be issued later)

Checking tyre pressures

28. Due to the heavy loads imposed on the tyres of this aircraft, it is important to ensure that the inflation pressures are always correct. When checking the pressures, as called for in the Servicing Schedule, a tyre pressure gauge must always be used.

Air drier

29 The air drier for the dry-air sandwich of the windscreen is located on the front face of Frame 8 just forward of the cabin starboard shelf and is

connected to the valve on the windscreen by a rubber tube. The system must be examined as follows:-

- (1) Examine the windscreen for signs of internal misting and moisture deposits. The presence of moisture indicates leaking connections, a cracked transparent panel, saturated silica gel or a blanked off air drier.
- (2) Examine the system for damage and security and check the colour of the silica gel crystals in the air drier tube. The crystals, which are normally blue in colour, should be changed when they become saturated with moisture and turn red. Use silica gel (Stores Ref.33C/790) when replenishing the air drier tube. ~~When replenishing is complete, check that both the inlet and outlet valves open at $\frac{1}{2}$ lb. per sq.in. pressure.~~

NOTE....

Before attempting to remove the air drier tube, the windscreen dry-air sandwich must be sealed against the ingress of moisture by unscrewing and removing the banjo-bolt and rubber tube from the windscreen valve connection. The valve is spring-loaded and will close, thus sealing the windscreen.

- (3) Before flight, ensure that the air drier is not taped or otherwise blanked off. *The cellotape around the body of the drier is not to be disturbed*
Removal of locking devices and covers

30. Before flight, remove the following locking devices, as well as any weather covers that may be fitted:-

- (1) Flying controls locking gear.

- (2) Control surfaces locking clamps.
- (3) Air intake sealing covers, or safety guards, if they have been fitted for ground running. Jet pipe and pitot head sealing covers. Any other covers.
- (4) Any picketing equipment and attachments.
- (5) Undercarriage safety stops.
- (6) Pilot's ladder.

Fitting drop tanks

31. The procedure for fitting the drop fuel tanks, the sequence for which must be strictly adhered to, is illustrated in fig.3. The jettison and reset mechanism is illustrated in fig.4.

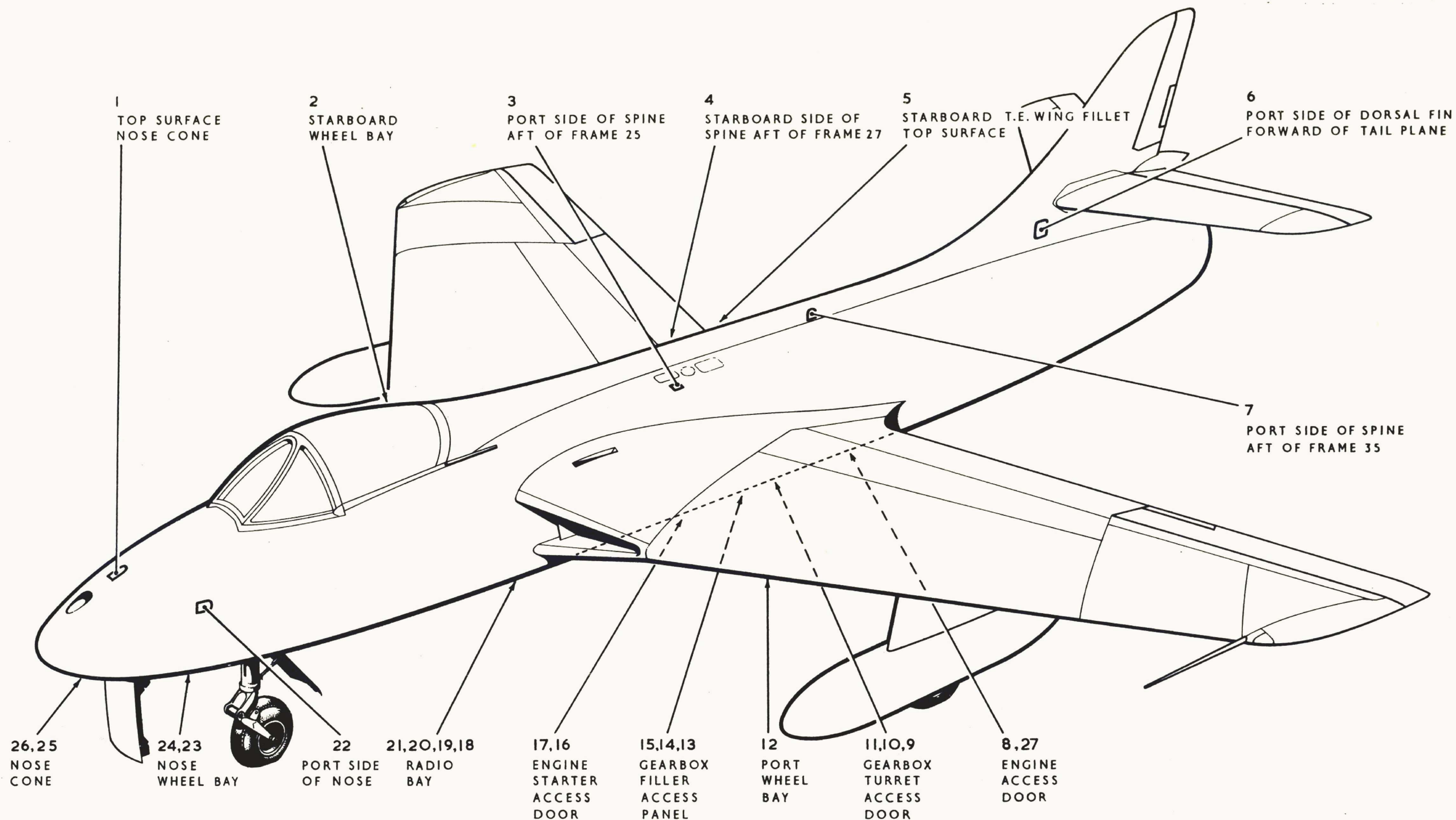

1 TOP SURFACE NOSE CONE
 2 STARBOARD WHEEL BAY
 3 PORT SIDE OF SPINE AFT OF FRAME 25
 4 STARBOARD SIDE OF SPINE AFT OF FRAME 27
 5 STARBOARD T.E. WING FILLET TOP SURFACE
 6 PORT SIDE OF DORSAL FIN FORWARD OF TAIL PLANE
 7 PORT SIDE OF SPINE AFT OF FRAME 35
 26,25 NOSE CONE
 24,23 NOSE WHEEL BAY
 22 PORT SIDE OF NOSE
 21,20,19,18 RADIO BAY
 17,16 ENGINE STARTER ACCESS DOOR
 15,14,13 GEARBOX FILLER ACCESS PANEL
 12 PORT WHEEL BAY
 11,10,9 GEARBOX TURRET ACCESS DOOR
 8,27 ENGINE ACCESS DOOR

- | | | | |
|--|--|--------------------------------------|---|
| 1 CAMERA GUN | 7 EXTERNAL AIR CONNECTION—FUEL SYSTEM | 14 FUEL FILTER, DE-ICING TANK FILLER | 21 CHARGING CONNECTION—EMERGENCY AIR BOTTLES |
| 2 CHARGING CONNECTION—AILERON ACCUMULATOR | 8 ENGINE OIL SUMP FILLER | 15 EXTERNAL HYDRAULIC SUPPLY VALVES | 22 DE-ICING TANK FILLER <i>12 deleted by madson ALD</i> |
| 3 ENGINE LIQUID FUEL STARTER TANK FILTER | 9 ENGINE FUEL FILTER | 16 FUEL SYSTEM DRAIN VALVES (2) | 23 CHARGING CONNECTION—WHEEL BRAKES |
| 4 COLD AIR UNIT DIPSTICK | 10 ACCESSORIES GEARBOX TURRET DRIVE FILLER | 17 DEFUELLING COCK | 24 CHARGING CONNECTION—OXYGEN BOTTLES |
| 5 HYDRAULIC RESERVOIR FILLER | 11 HYDRAULIC HANDPUMP | 18 FUEL SYSTEM DRAIN VALVES (2) | 25 EXTERNAL HOOD SWITCH |
| 6 CHARGING CONNECTION—ELEVATOR ACCUMULATOR | 12 REFUELLING AND DEFUELLING COUPLING | 19 EXTERNAL ELECTRICAL SUPPLY | 26 GROUND PRESSURISING CONNECTION |
| | 13 ACCESSORIES GEARBOX FILLER | 20 BATTERIES | 27 FUEL SYSTEM DRAIN VALVES (2) |

FIG. 1 SERVICING POINTS

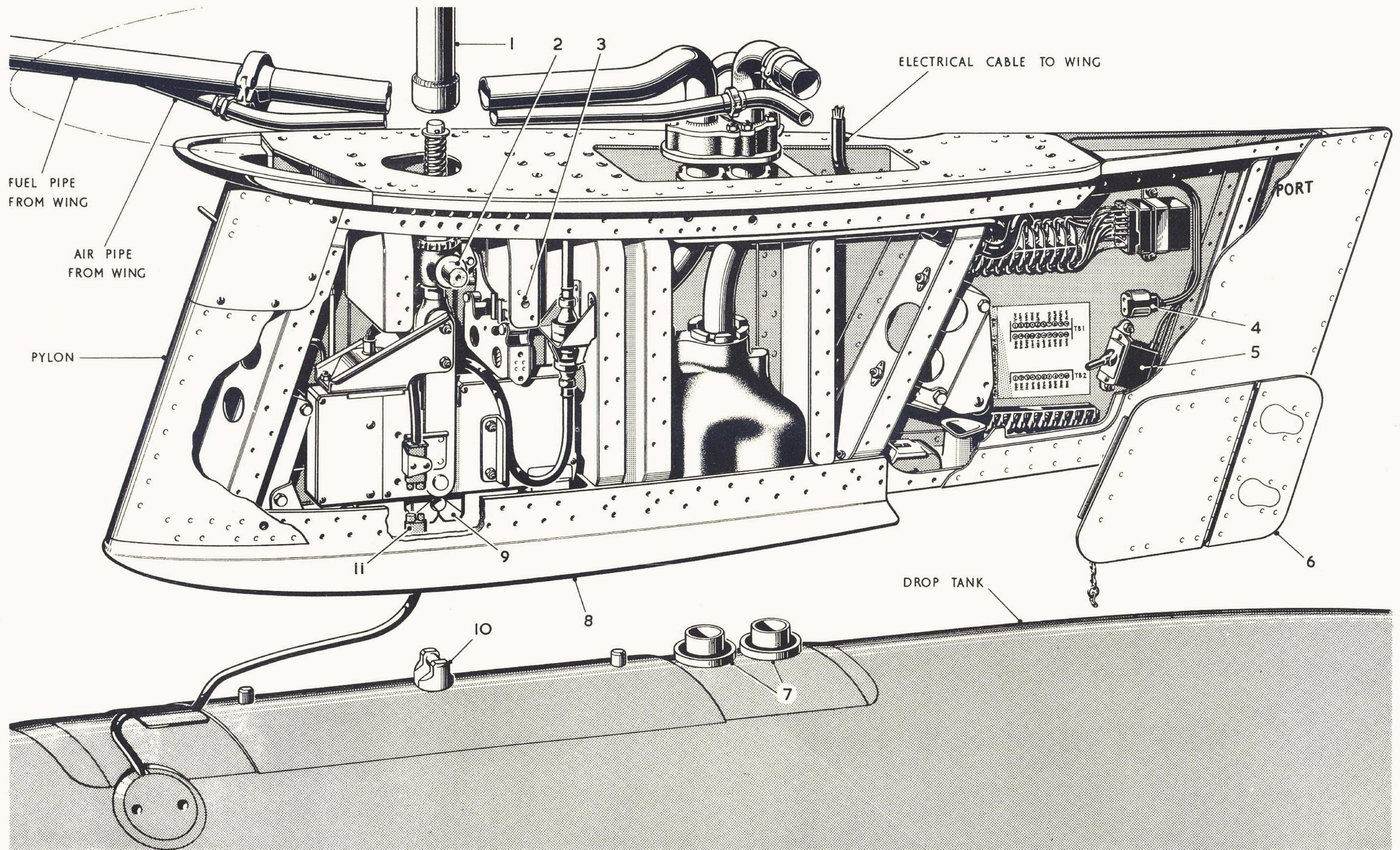

FIG. 3 FITTING DROP TANK

FITTING DROP TANK (Port described Stbd. similar) FIG.3.

1. Wheel drop tank into position under pylon.
2. Remove rear door (6) on outboard side of pylon and check that the change over switch (5) is in the DOWN position.
3. If the electro-mechanical release (9) is not open, press jettison button (3) shown also on fig.4, on port side of pylon and then reset by pressing the reset button on the stbd. side of pylon. (Should the electro-mechanical release be already open, only the reset button on the stbd. side should be used.)
4. Remove the access panel in the wing top skin and attach a crutching spanner (1) HAWKER Part No. B.204233 to the release housing support (2) and lower release housing.
5. Connect plug (11) on drop tank to socket in pylon.
6. Raise the tank until the tank lug (10) is engaged by electro-mechanical release (9).
7. Now, by means of the crutching spanner (1) raise the tank until the fore and aft spigots are engaged in the holes provided in the sole plate (8) and the tank adaptors (7) are making contact with the fuel and air valves in the valve body and check that the electrical cable from the tank to the plug (11) is not trapped between the tank and the sole plate.
8. Apply the final crutching load by using an 'ACRATORCK' spanner (Mk.VI model B.3) attached to the adaptor on the crutching spanner.
9. Check that the release is fully locked by means of the cocking test socket (4).
10. Remove the 'ACRATORCK' and crutching spanners and replace access panel in wing.
11. Replace the rear door (6).

REMOVING DROP TANK

1. Support the drop tank and press the jettison button (3) and Fig.4, on the port side of pylon.

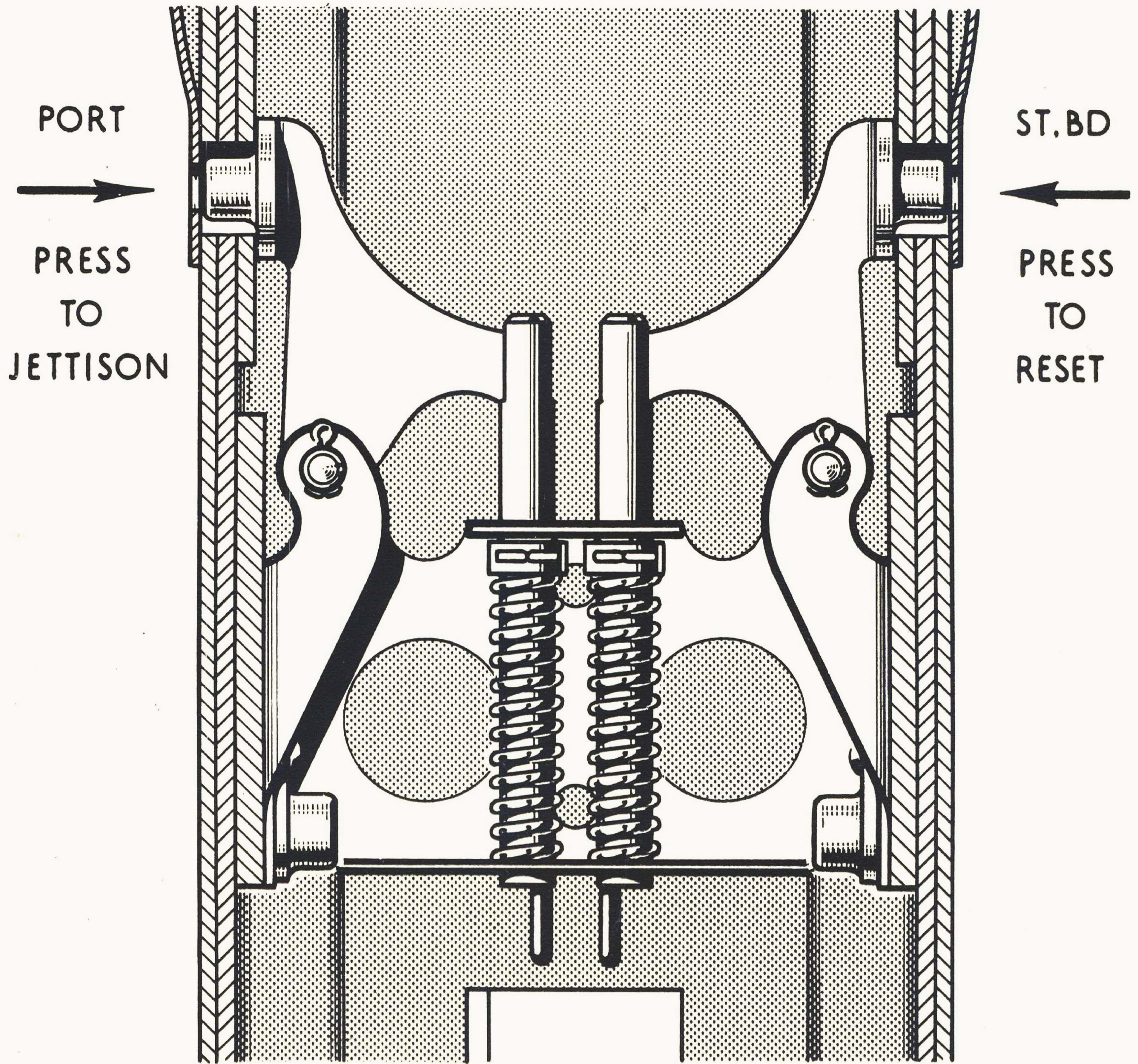

FIG. 4 JETTISON AND RESET MECHANISM

This file was downloaded
from the RTFM Library.
Link: www.scottbouch.com/rtfm

Please see site for usage terms,
and more aircraft documents.

