

CHAPTER 1

FUSELAGE

LIST OF CONTENTS

	<u>Para.</u>		<u>Para.</u>
Introduction . . . . .	1	Rear fuselage and tail cone	
		Structure . . . . .	14
DESCRIPTION		Fuel tank compartment . . . . .	15
General . . . . .	2	Air brake flap . . . . .	16
Nose piece and front fuselage		Jet pipe mounting . . . . .	17
Structure . . . . .	3		
Cabin . . . . .	4	SERVICING	
Windscreen and hood . . . . .	5	General . . . . .	18
Armament package . . . . .	7	Testing and adjusting hood jettison mechanism	20
Radio mountings . . . . .	8	Windscreen dry-air sandwich . . . . .	21
Forward transport joint fittings . . . . .	9	Lubrication . . . . .	22
Centre fuselage and stub wings			
Structure . . . . .	10	REMOVAL AND ASSEMBLY	
Fuel tank compartment . . . . .	11	General . . . . .	23
Engine compartment . . . . .	12	Removal of nose piece . . . . .	24
Rear transport joint fittings . . . . .	13	Removal of tail cone . . . . .	25

LIST OF ILLUSTRATIONS

	<u>Fig.</u>		<u>Fig.</u>
Front fuselage nose piece . . . . .	1	Removing front fuselage (1) . . . . .	10
Front fuselage . . . . .	2	Removing front fuselage (2) . . . . .	11
Centre fuselage and stub wing (1) . . . . .	3	Removing rear fuselage . . . . .	12
Centre fuselage and stub wing (2) . . . . .	4	Sliding hood, jettison mechanism and	
Rear fuselage . . . . .	5	controls (1) . . . . .	13
Slinging and trestling front fuselage . . . . .	6	Sliding hood jettison mechanism and	
Slinging and trestling centre fuselage . . . . .	7	controls (2) . . . . .	14
Slinging and trestling rear fuselage . . . . .	8	Removing air brake . . . . .	15
Typical fastener for nose piece . . . . .	9		

## WARNING

An aircrew ejection seat is fitted to this aircraft. Before attempting to enter the cabin, therefore, ensure that the instructions given in the Ejection Seat Warning, following the Introduction at the beginning of this volume, have been carried out. In the interests of safety, this is very important.

## Introduction

1. This chapter contains a general description of the fuselage, together with the lubrication and servicing information necessary to maintain it in an efficient condition. Illustrations showing the method of slinging trestling and dismantling into its major components are also included.

## DESCRIPTION

### General

2. The fuselage is an all metal monocoque structure, which is built in three main portions to facilitate manufacture and transport. The front fuselage is provided with a detachable nose piece and houses the pilot's cabin, armament package and radio equipment while the centre fuselage, which is constructed with the stub wings as an integral part, contains the engine and the forward fuel tanks. The rear fuselage, which is constructed with the lower portion of the fin as an integral part and is terminated by a detachable tail cone, houses the engine jet pipe and carries the hydraulically-

operated air brake installation. The rear fuel tanks, which fit around the rear of the engine, are also housed in the rear fuselage. The three major components of the fuselage are illustrated in fig.2, 3, 4 and 5.

Nose piece and front fuselage (fig.1 & 2)

### Structure

3. The detachable nose piece, which extends from the radome to frame 3, consists of a light alloy skin supported by frames and houses the radar scanning equipment, together with the camera gun. The front fuselage continues from frame 3 to frame 18, which forms the front frame of the forward transport joint. The structure consists of a number of frames and four longerons reinforced by a box-sectioned keel member extending between frames 6 and 11, the whole assembly being covered with a metal skin. The nose wheel is pivoted to the keel member at frame 8 and when retracted is enclosed in the front fuselage by fairings. The pilot's cabin is housed between frames 6 and 14, while the armament package is located between frames 15 and 17A with the gun barrels projecting forward under the cabin floor. The radio bay is situated immediately forward of the transport joint.

### Cabin

4. The pilot's cabin, which is protected by heavy plating and provided with an ejection seat, is enclosed by a windscreen and an electrically-operated hood. The hood slides rearwards for entry and exit and may also be jettisoned in an emergency. To enable the cabin to be pressurised, it is sealed

CAMERA CONE AND  
RAM AIR DUCT ENTRY

CAMERA GUN  
MAGAZINE DOOR

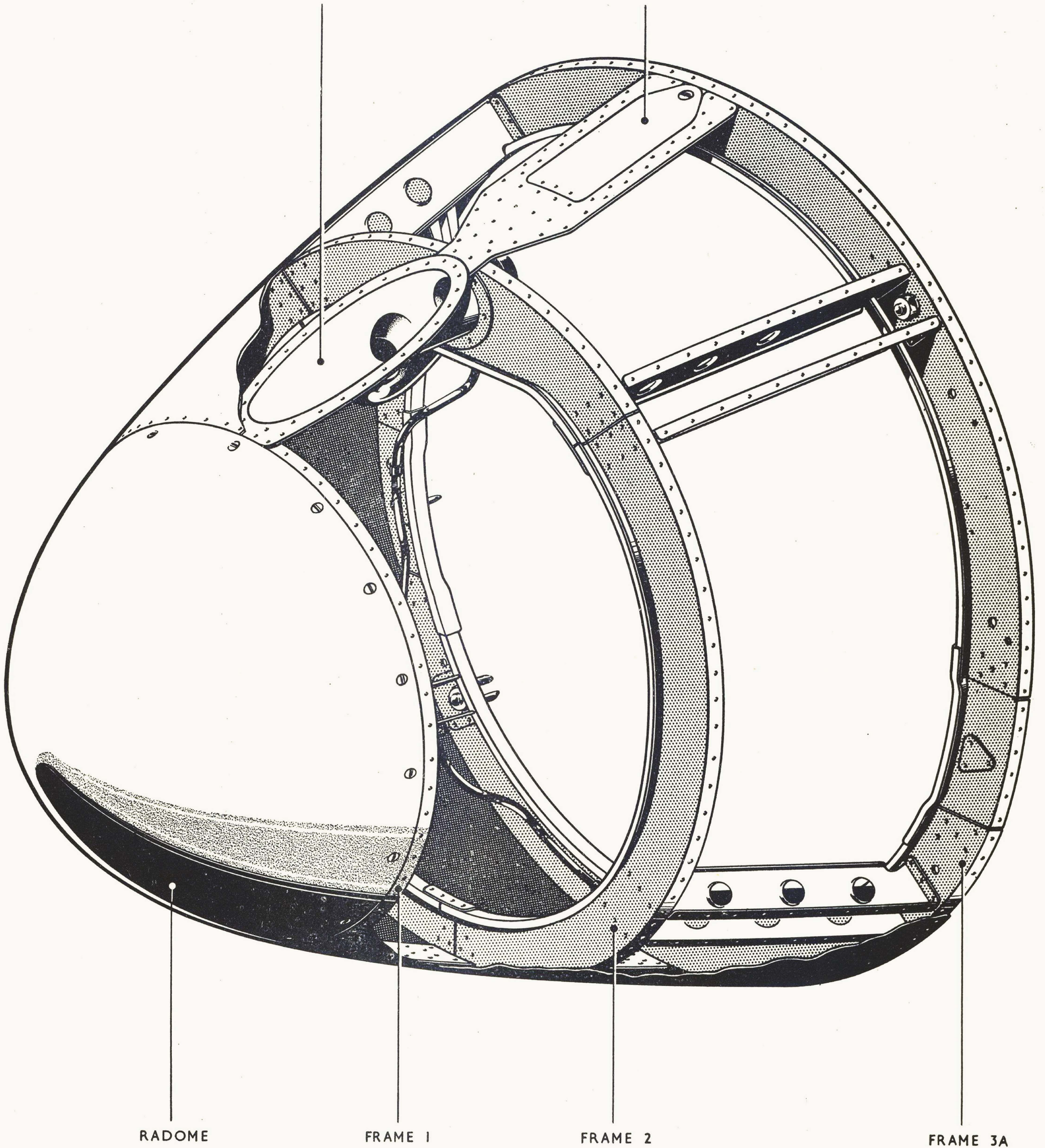

FIG. 1 FUSELAGE NOSE PIECE

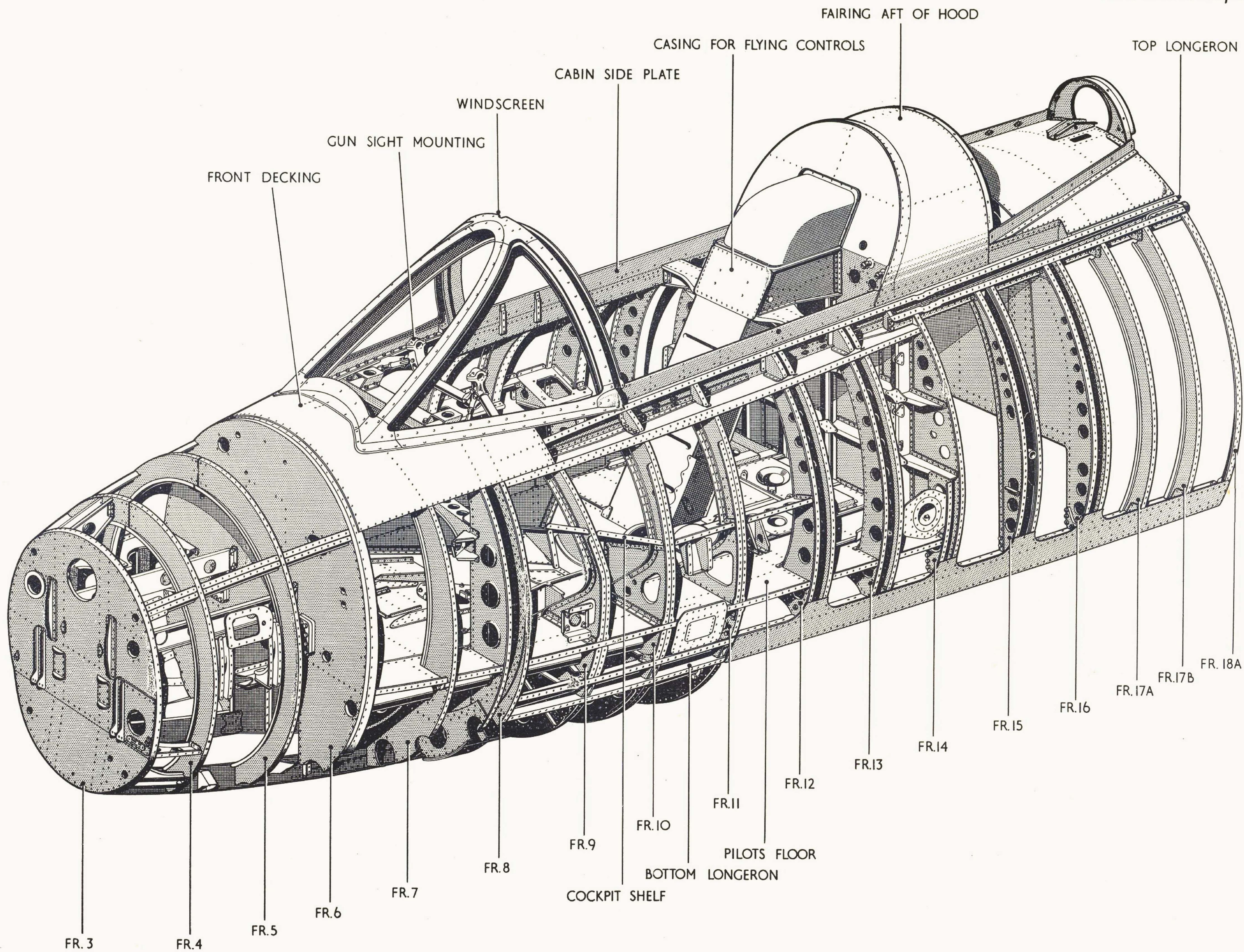

FIG. 2 FRONT FUSELAGE

from the remainder of the airframe by a floor extending from frame 6, which is a solid bulkhead to a diaphragm at frame 14. Ejector seat leg restraint anchorages in the form of a pair of fork fittings are fitted to the cabin floor. Above the floor the fuselage structure is enclosed to form side walls and above these walls are shelves for controls and instruments. The centre instrument panel, together with the port and starboard side panels are located at the forward end of the cabin above the shelves, on a structure, which also carries the gun sight. This structure extends across the top of frame 8 and is stiffened by two tubular struts projecting forwards to frame 7. The gun sight is carried on a retractable mounting located above the centre instrument panel.

#### Windscreen and hood

5. The windscreen consists of a flat bullet-proof centre panel and two curved transparent side panels all three of which are held in a cast light-alloy frame secured to the cabin decking. The centre panel consists of two plates of glass between which is a layer of dry-air to prevent misting, the air being maintained in a dry state by a silica gel container, mounted on the forward face of frame 8 on the starboard side and connected to a valve on the bottom of the windscreen by a plastic tube. An adjustable convex type rear view mirror is attached to the top of the windscreen frame. The hood is moulded from a single sheet of transparent plastic mounted in a frame consisting of a steel arch member at the forward end and two edge members at the sides. A rack and roller assembly is bolted to each edge member and the complete hood slides in rails attached to the structure by locks, located just aft of frame 10 and forward of frame 13, and by a pivot point just aft of frame 16.

6. The cabin hood is opened and closed by an electric actuator which drives a cross-shaft carrying pinions which engage with the racks on each side of the hood. The actuator is controlled by a control box and integral clutch lever situated on the port side of the cabin just forward of frame 10. The lever is provided to disengage the actuator clutch and, at the same time, deflate the hood seal so that the hood can be moved by hand. In an emergency the cabin hood may be jettisoned by the use of a control handle which projects upwards from the forward end of the cabin port shelf. Pulling this handle fires the hood jettison gun which opens the locks securing the hood side channel members and gases from the gun are utilised to jettison the hood. An interconnection between the control handle and the spring-loaded release unit ensures that the hood locks open in the event of the hood jettison gun failing to fire. In the event of the pilot being physically incapable of operating this control while the aircraft is on the ground, there is an external release ring enclosed behind a transparent break-in panel on the port side of the fuselage below the cabin. Pulling the enclosed ring operates the spring-loaded release unit to release the locks securing the hood side channel members, deflates the hood seal and declutches the hood motor so that the hood may be lifted off by hand. Finger holes between the hood and windscreen are provided to facilitate the removal of the hood.

#### Armament package

7. The armament package consists of a removable container, which carries four 30 mm. Aden guns together with their ammunition. The package is provided with guide spigots at the forward end which engage with brackets attached to the bottom longerons

and is supported by six spherical ended mounting spigots, three on each side, which project downwards from the bottom longerons, to engage with sockets integral with the package. The mountings are locked by rack operated pins, which pass through holes in the mounting spigots and sockets, the locking mechanisms being located on each side at the forward end of the package and operated by a special removable key. The forward portions of the gun barrels, which are detachable from the package, are staggered and extend forward under the cabin floor to blast tubes in the underside of the fuselage structure. The guns are electrically-fired and controlled by a trigger on the control column hand-grip. For a full description of the armament installation, reference should be made to Sect.7, Chap.3 of this volume.

#### Radio mountings

8. The radio bay is situated in the front fuselage, where it extends aft from frame 16 to frame 19. This bay also contains certain components of the aircraft's electrical system. The mountings consist of an upper and lower structure, each supporting anti-vibration mounting racks for the transmitter-receivers and associated equipment. The upper structure consists of two angle-sectioned beams with a platform carried between them. The complete assembly extends across the radio bay and is bolted to frames 17A and 17B. Another platform is attached to the starboard side of the beam bolted to frame 17B and extends aft to brackets on frame 19. The lower structure extends along the port side of the radio bay and consists of a number of square tubes which are bolted together through gusset plates to form two platforms, one located above the other. The forward end of the structure is in the form of a diaphragm and the whole assembly is bolted to brackets on frames 16 and 19. For a full description of the radio installation, reference should be made to Sect.6 of this volume.

#### Forward transport joint fittings

9. The front and centre fuselage structures are assembled together at a butt joint formed by the flanges of frames 18 and 18B, which are bolted together and by special attachments at the four longerons. These attachments consist of large threaded fittings bolted to the front fuselage longerons, which extend aft through frame 18 to engage with special captive nuts carried on spigots projecting forwards through frame 19 of the centre fuselage from fittings bolted to stringers C and H. The special nuts are locked to the spigots with nickel alloy wire when assembled to the front fuselage fittings.

#### Centre fuselage and stub wings (fig.3 & 4)

##### Structure

10. The centre fuselage extends from frame 18B to frame 40A, both of these frames forming transport joints. It is a monocoque structure consisting of a number of frames and stringers covered with a light-alloy skin, at the top of which is a spine member enclosing the flying controls. Frames 19, 25 and 32 are of heavier construction than those of the remaining frames and continue outward to form the nose, main and rear spars of the stub wings, which are an integral part of the centre fuselage structure. The stub wing consists of these three spars, together with a number of ribs and diaphragms, which are covered externally by a light-alloy skin and internally by the air-intake and boundary layer ducting. The spars contain high-tensile steel fittings to which the outer wings are attached.



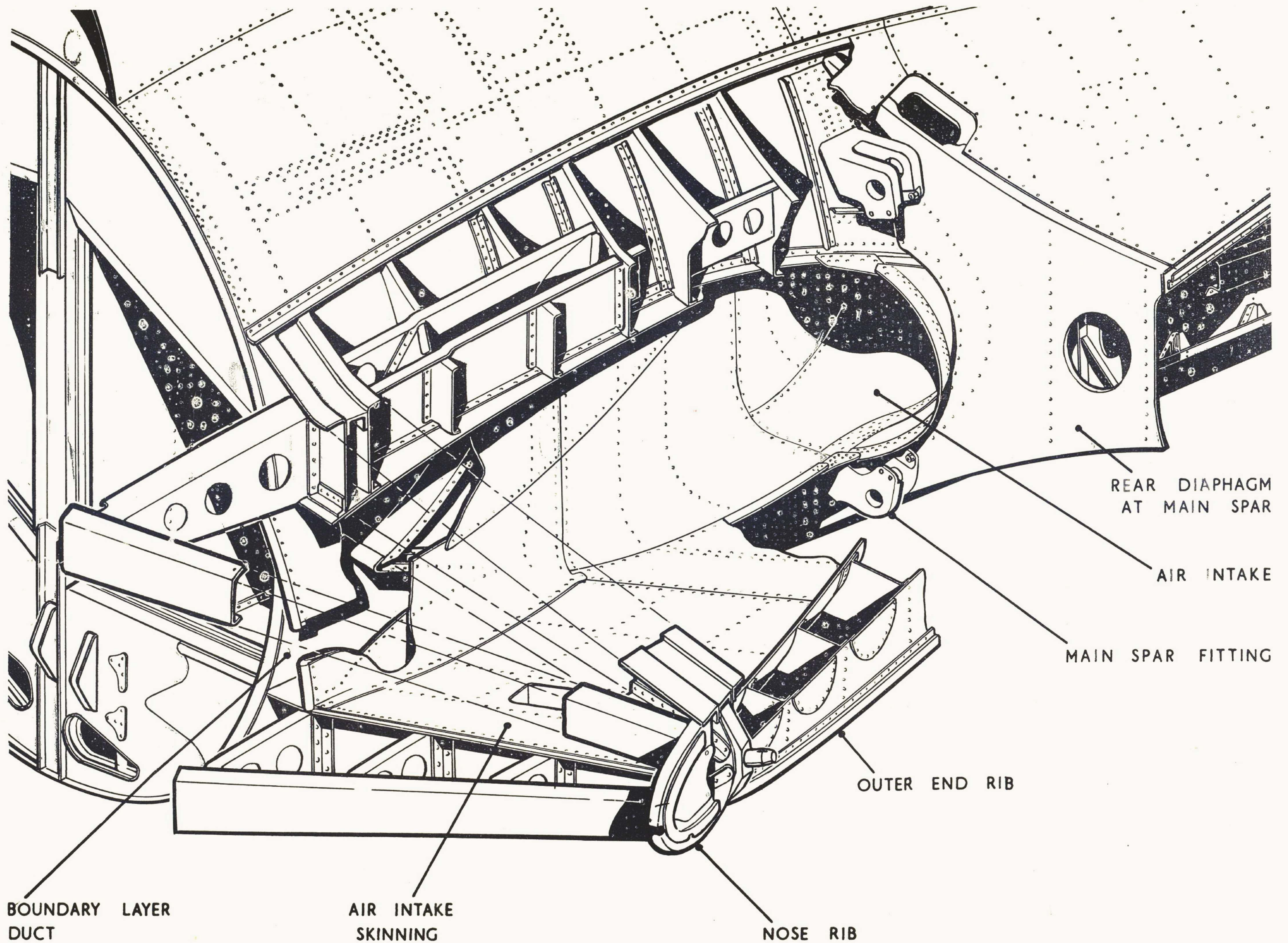

FIG.4 CENTRE FUSELAGE AND STUB WING (2)

## Fuel tank compartment

11. The structure between frames 19 to 25 of the centre fuselage is double skinned to form a compartment in which the front flexible bag type fuel tanks are supported. For a full description of the fuel tank installation, reference should be made to Sect.4, Chap.2 of this volume.

## Engine compartment

12. The engine is situated aft of the main spar frame, being mounted at frames 34 and 40A, with the engine-driven accessories gearbox between frames 29 and 30. A diaphragm at frame 38 engages with the engine to form a firewall and to divide the engine compartment into two zones for cooling purposes. Another firewall at frames 29 and 30 isolates the engine bay from the engine starter bay. For further details of the engine installation, reference should be made to Sect.4, Chap.1, of this volume.

## Rear transport joint fittings

13. The centre and rear fuselage structures are assembled together at frames 40A and 40B by special attachments at fifteen points between these frames. These attachments consist of large threaded fittings bolted to the stringers of the centre fuselage and extending aft through frame 40A to engage with special captive nuts carried on fittings bolted to the stringers of the rear fuselage, which project forward through frame 40B. When assembled these special nuts are locked together with nickel alloy wire and the gap between the two frames is covered by a fairing strap.

## Rear fuselage and tail cone (fig.5)

## Structure

14. The rear fuselage extends from frame 40B (rear transport joint) to frame 57. It consists of a number of frames and stringers covered with a light alloy skin to form a monocoque structure, at the top of which is a spine member enclosing the flying controls. Frames 52 and 55 are of heavier construction than the remaining frames and extend upwards to form the major framework of the lower fin structure, which is integral with the rear fuselage. The lower fin structure consists of the above major frames together with a dorsal fin extending forward to the spine member and an anti-buffet fairing extending aft below the rudder. The upper portion of the fin, which carries the rudder is attached to the lower part by fittings incorporated at the top of frames 52 and 55, while the tail plane is pivoted on a fitting at frame 55 and anchored at the leading edge to the tail plane actuator in the lower fin structure (Sect.3, Chap.3). A small bumper block type tail skid is attached to the bottom of frame 55 to take the loads should the tail strike the ground during landing or take-off. The bottom skin between frames 47 to 50 is cut away and the gap so formed is reinforced and boxed in by side members and a top skin to form a housing for the hydraulic air brake jack. The jack is anchored on a bolt extending between fittings bolted to the aft ends of the side members and extends forward in the housing to engage with the air brake flap which is attached by two extended hinges to channel fittings located between frames 45 and 46 on each side of the aircraft. The tail cone, which is detachable, is secured to the rear fuselage by four toggle fasteners, together with locating spigots. It extends from frame 58 to 63 and consists of six frames and a tail piece, covered with a light-alloy skin stiffened by butt straps.

The tail piece incorporates a stainless steel duct, which engages with the jet pipe. A small tail fairing is incorporated at the top between frames 58 and 60.

#### Fuel tank compartment

15. Internal structure between frames 41 and 45, consisting of tank support beams and skinning, forms an annular compartment around the rear of the engine in which the rear flexible bag-type fuel tanks are housed. For further details of the tank installation and fuel system generally, reference should be made to Sect.4, Chap.2 of this volume.

#### Air brake flap

16. This structure consists of a series of curved formers attached to a channel sectioned centre rib with a hinge rib on either side and a curved nosing at the forward end. The lower surface of the structure is completely covered with a light-alloy skin, but its upper surface is only covered at the forward and centre portion. Each hinge rib carries an arm of the extended hinges, which engage with fittings incorporated in the rear fuselage. The centre rib incorporates the anchorage fitting to which the operating jack is attached. The complete assembly is carried under the rear fuselage on hinge fittings as described in para.14. The air brake is designed so that it embraces the fuselage when in the up position.

#### Jet pipe mounting

17. The jet pipe is rigidly secured to the engine at its forward end and extends aft to terminate at the end of the tail cone. The pipe is supported at frame 55 by blocks, attached to each side of the pipe, which engage with mounting slides secured to the fuselage structure. These blocks move along

the slides to allow for expansion of the pipe. A rail incorporated at the top of the fuselage between frames 48 and 56 is provided to facilitate jet pipe assembly and removal, small rollers on the pipe running along this rail during these operations. For further details of the jet pipe installation, reference should be made to Sect.4, Chap.1 of this volume.

## SERVICING

### General

18. In general, the only servicing required to the fuselage itself is that described in para.19 below. Otherwise the servicing is confined mainly to the systems and accessories which are contained in the fuselage and which are dealt with in their respective chapters.

19. A regular examination of the fuselage structure must be carried out to ensure that no damage, such as buckling of the skin, corrosion or loose nuts, rivets, etc. has occurred. If any damage is found it must be rectified in accordance with authorised procedure before the next flight. It is also necessary to check that all the detachable access panels and hinged doors are securely locked and flush with the surrounding structure. This is very important as many of these are stress bearing panels and the safety of the aircraft is dependent upon their correct fitment. Extreme care must, therefore, always be taken, during fitting or removal, to ensure that they are not damaged or distorted in any way.

### NOTE...

Any alteration in contour will give rise to a shock-wave, resulting in a vast increase in drag and consequently a loss in performance.

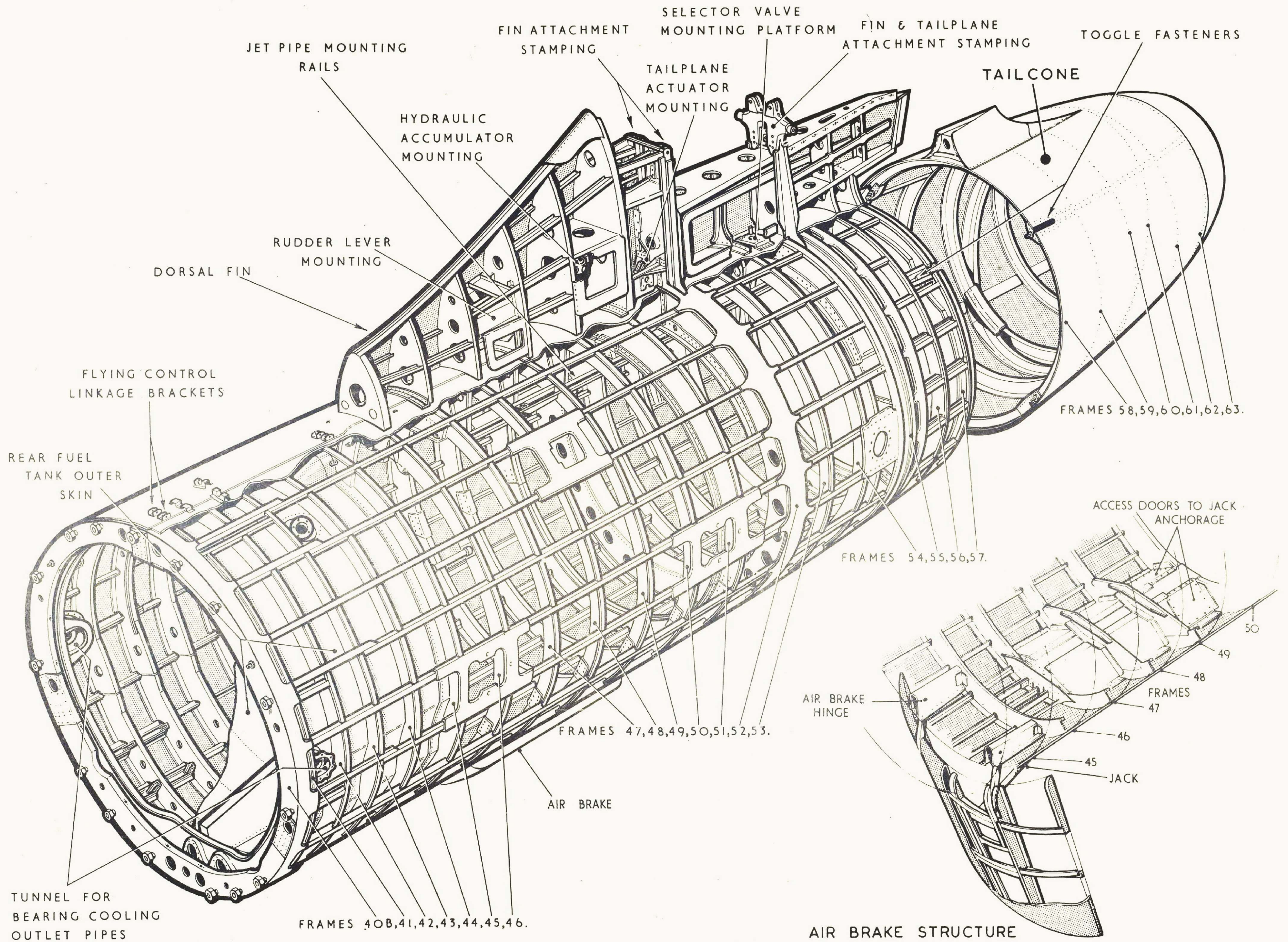
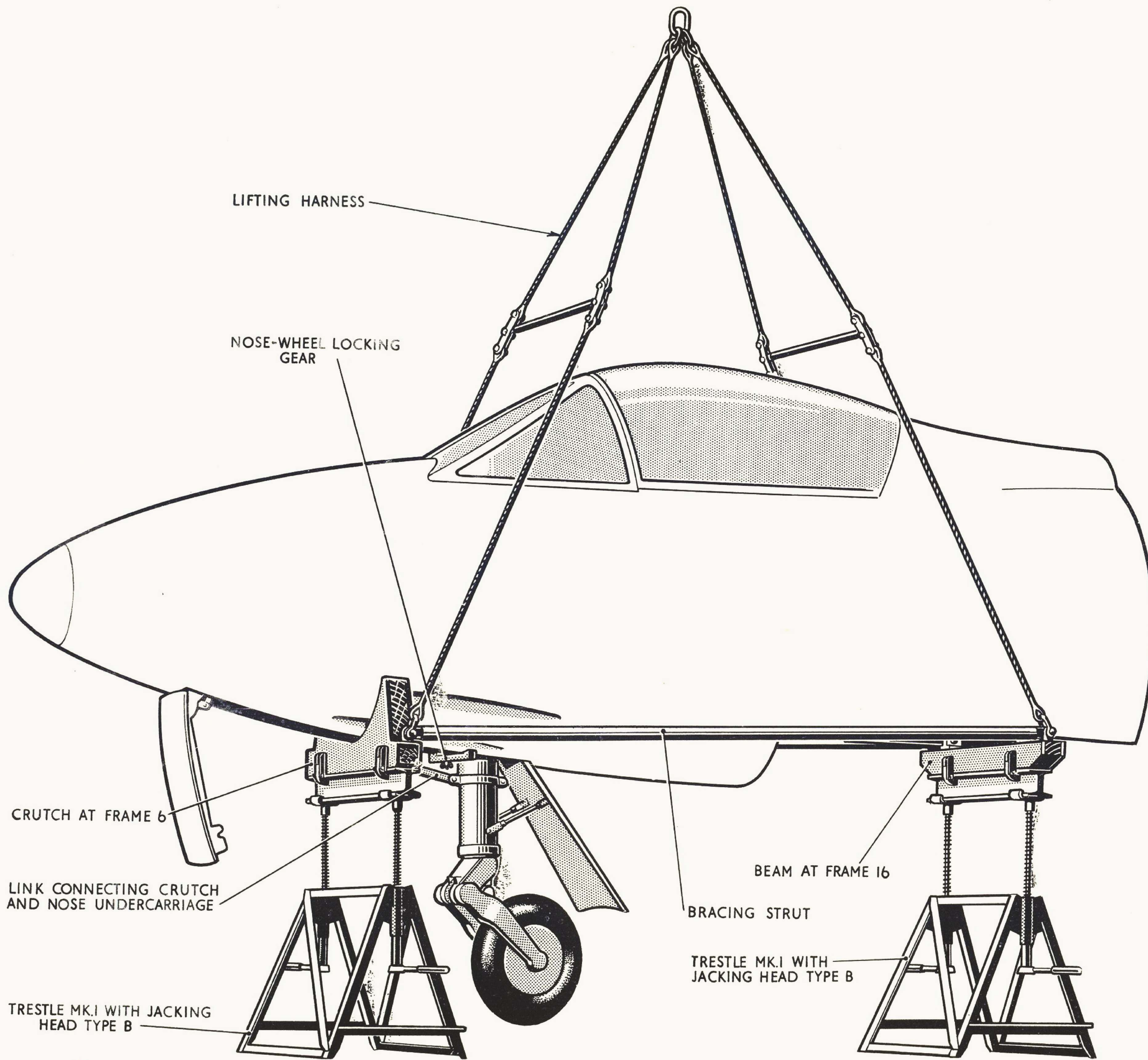
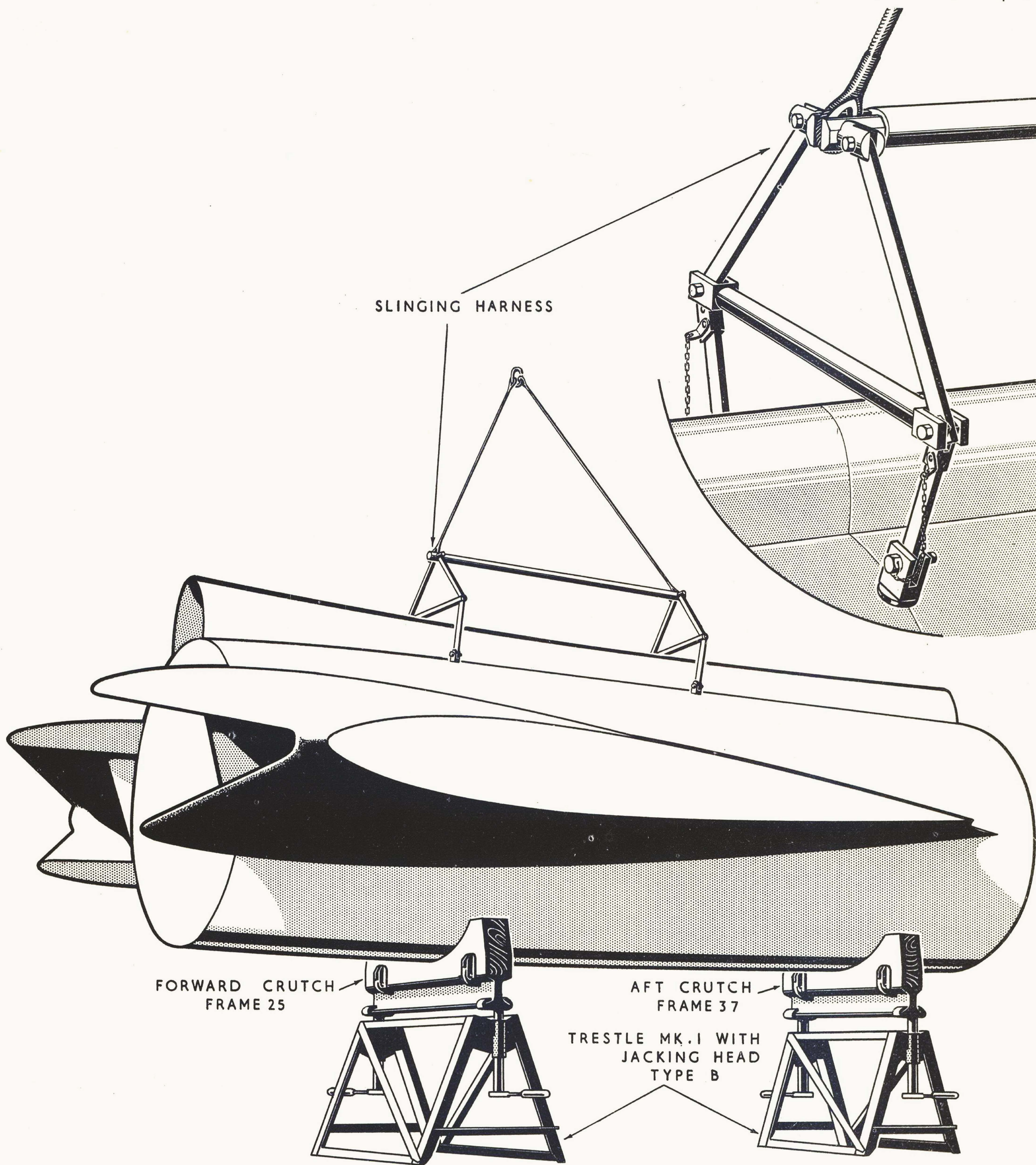

FIG. 5 REAR FUSELAGE

RESTRICTED

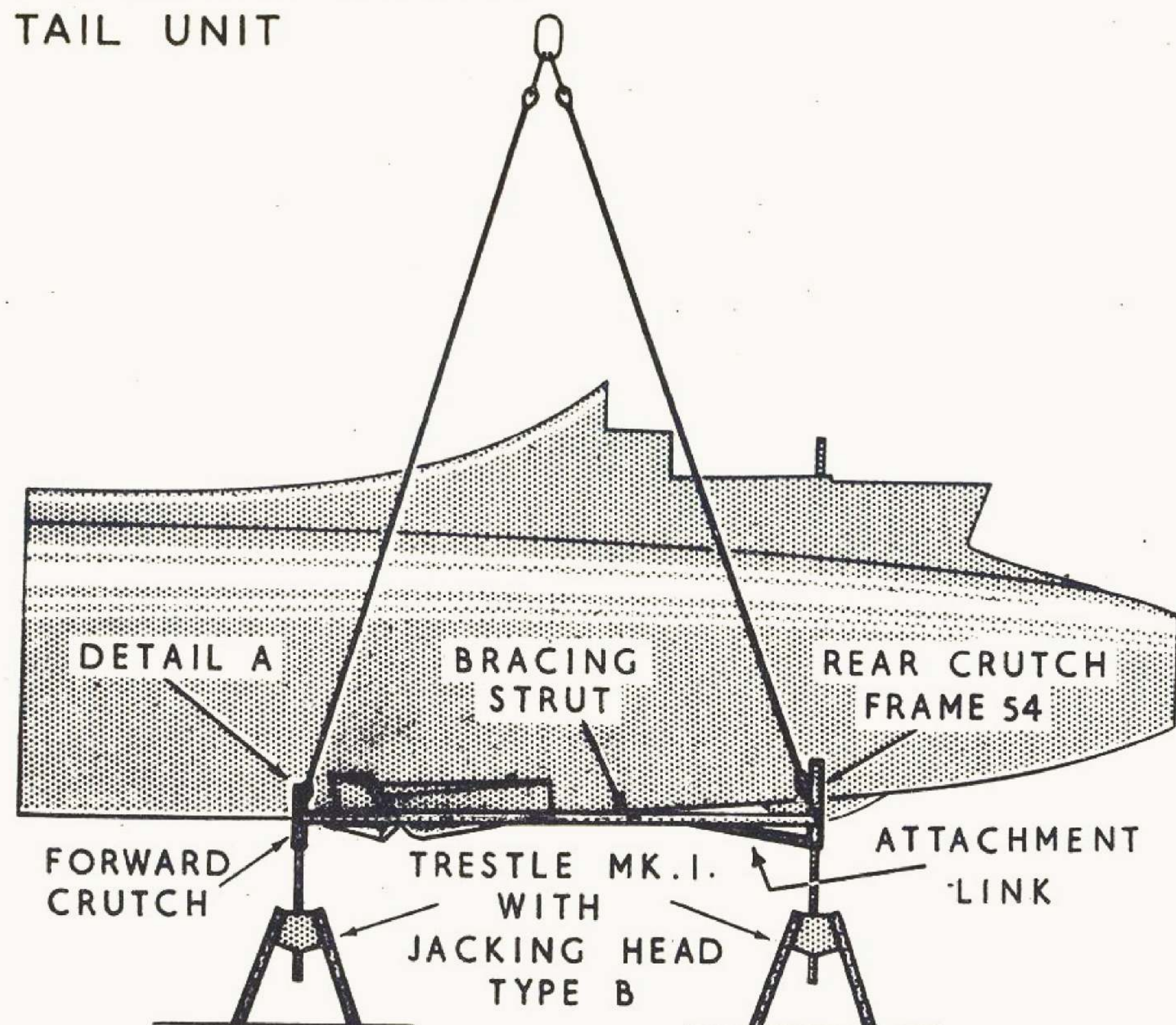

**FIG. 6 SLINGING AND TRESTLING FRONT FUSELAGE**

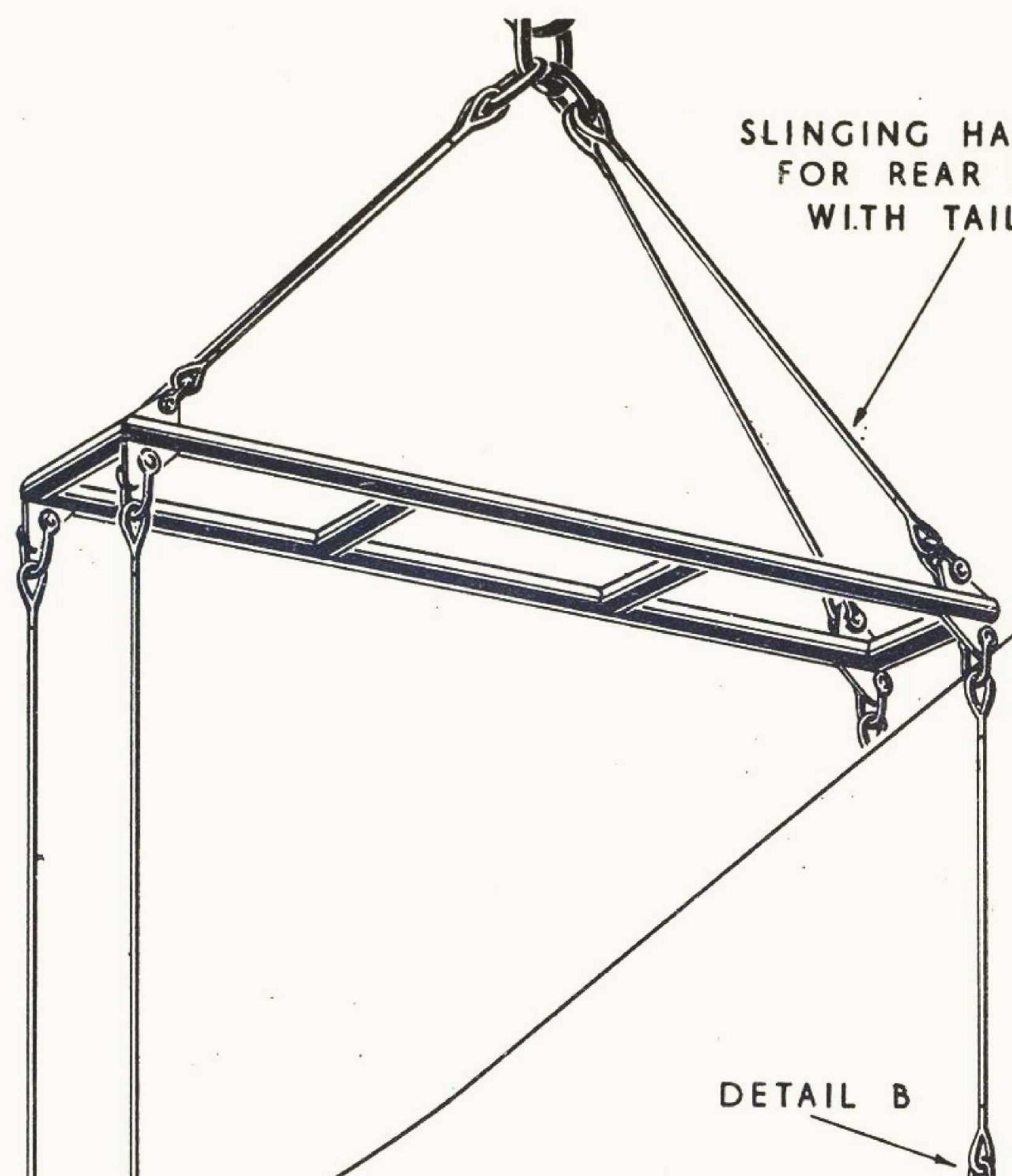

**FIG. 7 SLINGING AND TRESTLING CENTRE FUSELAGE**

SLINGING OF REAR FUSELAGE WITHOUT TAIL UNIT



SLINGING HARNESS FOR REAR FUSELAGE WITH TAIL UNIT



DETAIL A

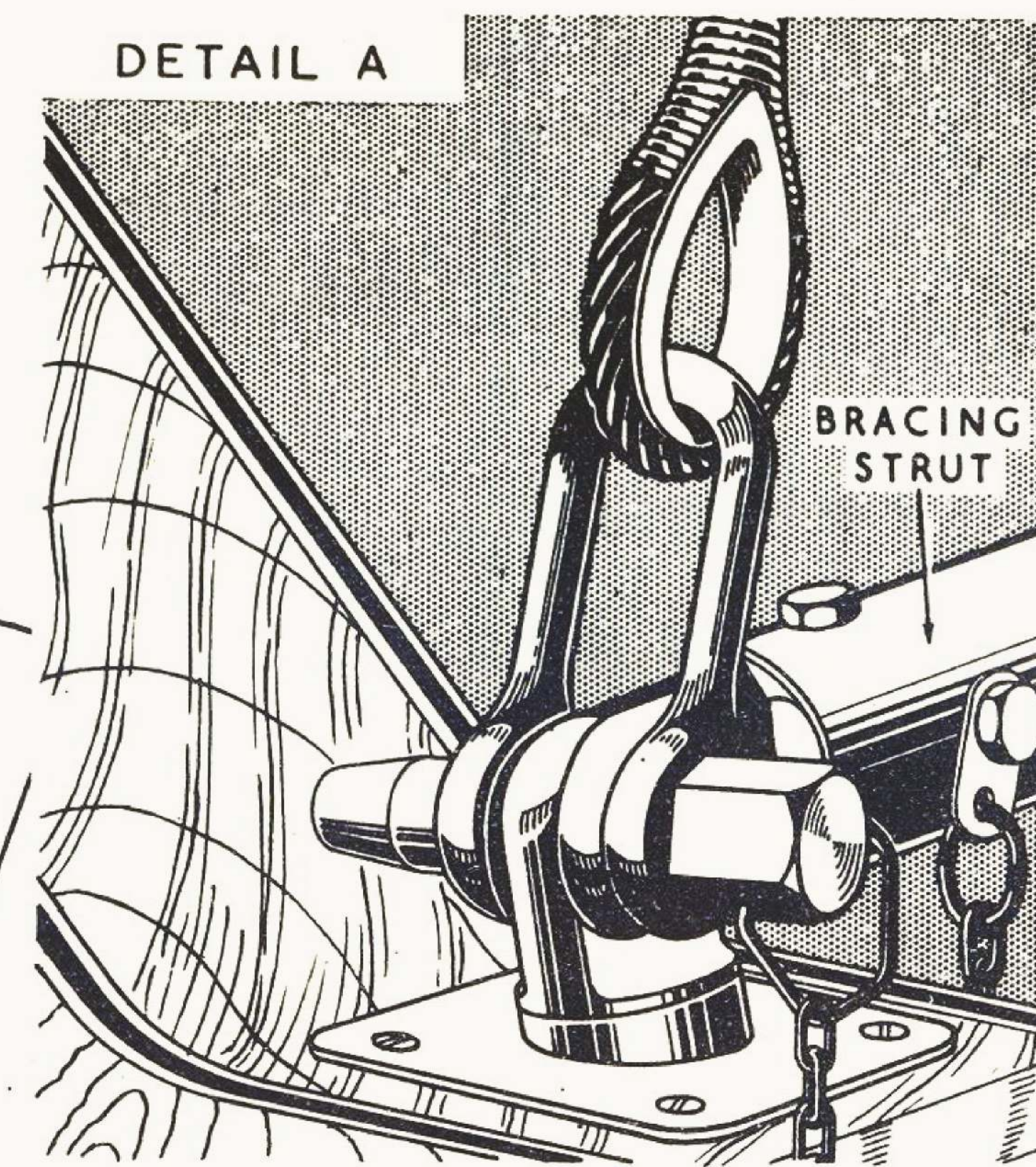

DETAIL B

DETAIL B

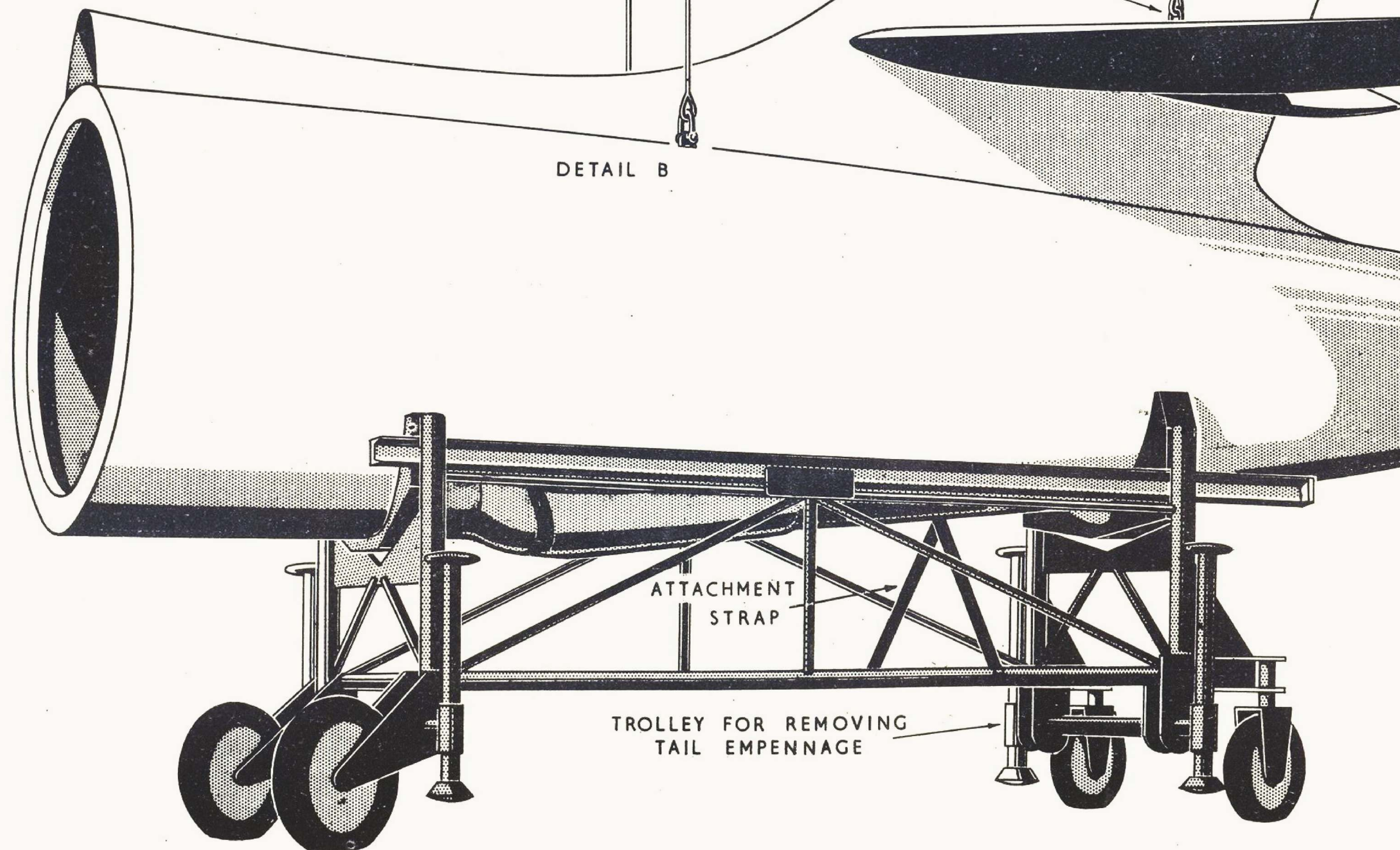

DETAIL B

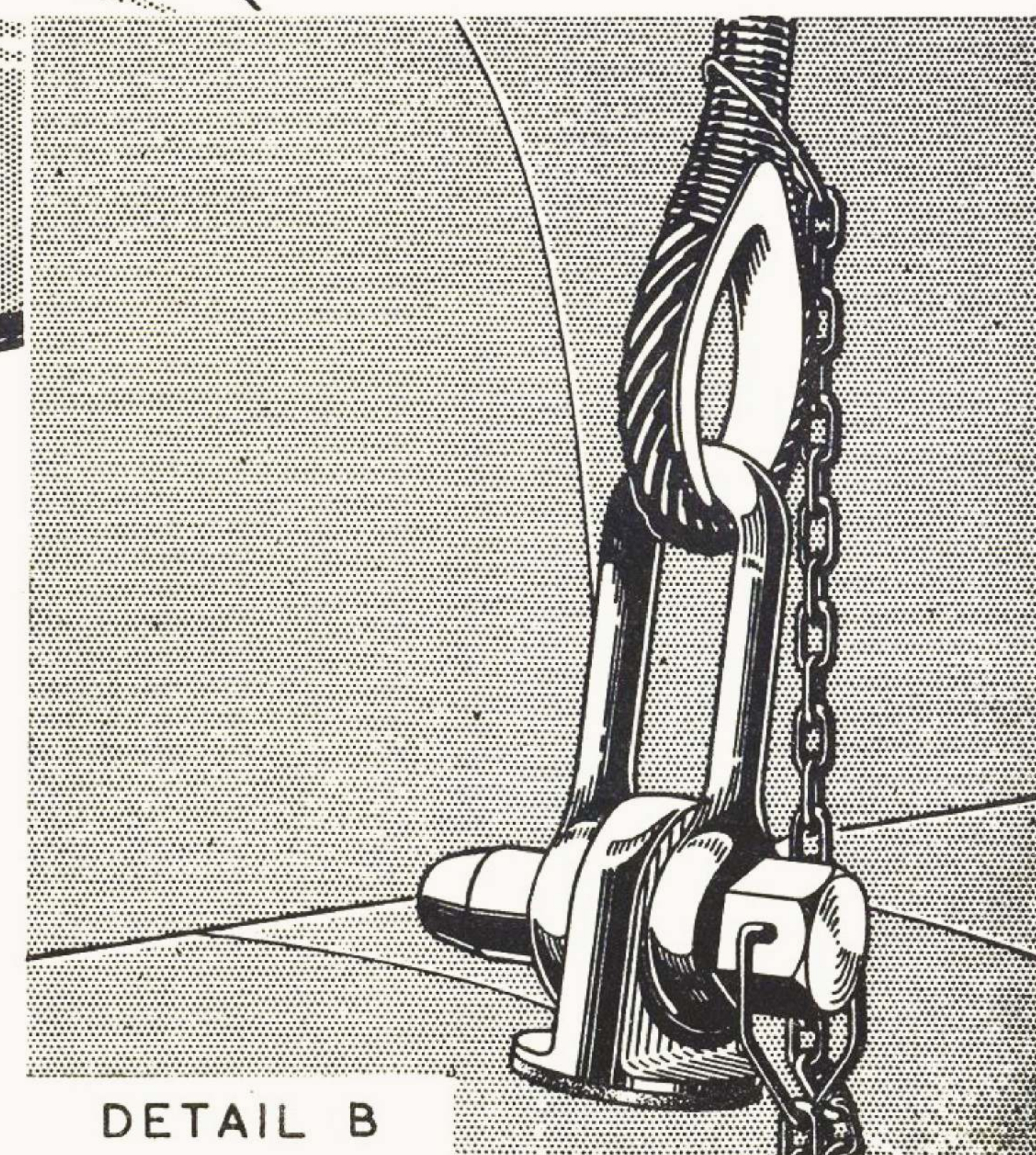

FIG. 8 SLINGING AND TRESTLING REAR FUSELAGE

## Testing and adjusting hood jettison mechanism

20. The method of testing and adjusting the hood jettison mechanism is contained in the key to the illustrations showing the procedure for the removal of the hood, (fig.13 and 14) of this chapter.

## Windscreen dry-air sandwich

21. The procedure for examining the air drier of the windscreen dry-air sandwich installation is contained in Sect.2, Chap.2 of this volume.

## Lubrication

22. The lubrication points for the fuselage and the sliding hood, together with the types of lubricant to be used are given on fig.13 of this chapter.

## REMOVAL AND ASSEMBLY

## General

23. The separation of the fuselage at its transport joints and the removal of various components, together with the method of slinging and trestling is shown in the illustrations contained in this chapter. In general, the assembly of the unit is a reversal of the removal, but where there is any special assembly feature it is covered in the key to the illustration.

## Removal of nose piece (fig.9)

24. The nose piece is a quickly detachable unit held in position by four Hawker type fasteners and four locating dowels. To release the fasteners, gain access through the nose wheel bay, remove the pip pin passing through the lever and latch, and move the latch in the direction of the arrow A to free the lever, which should then be pulled in the direction of arrow B thus freeing the hook from the fork of the nose piece. The nose piece may now be withdrawn from the front fuselage.

## NOTE...

After assembling the nose piece to the front fuselage each of the four fastening hooks, painted white, must be checked through the viewing aperture in the lever to ensure that it has engaged properly with the nose piece fork.

## Removal of tail cone

25. The tail cone is located to the rear fuselage by four dowels and is secured by four toggle fasteners. To remove this unit it is only necessary to unlock the fasteners and withdraw the cone rearwards.

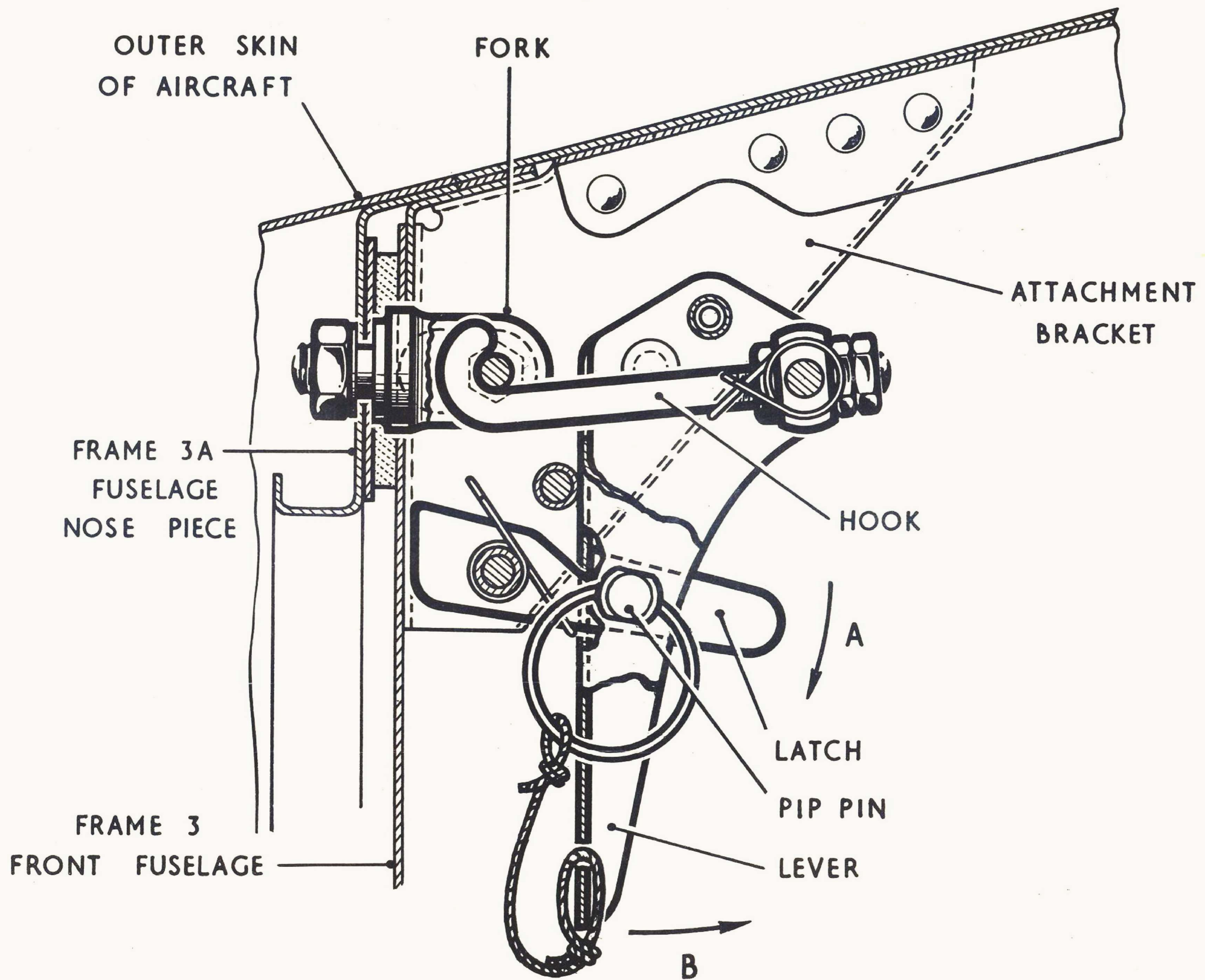

FIG. 9 TYPICAL FASTENER FOR  
 FUSELAGE NOSE PIECE

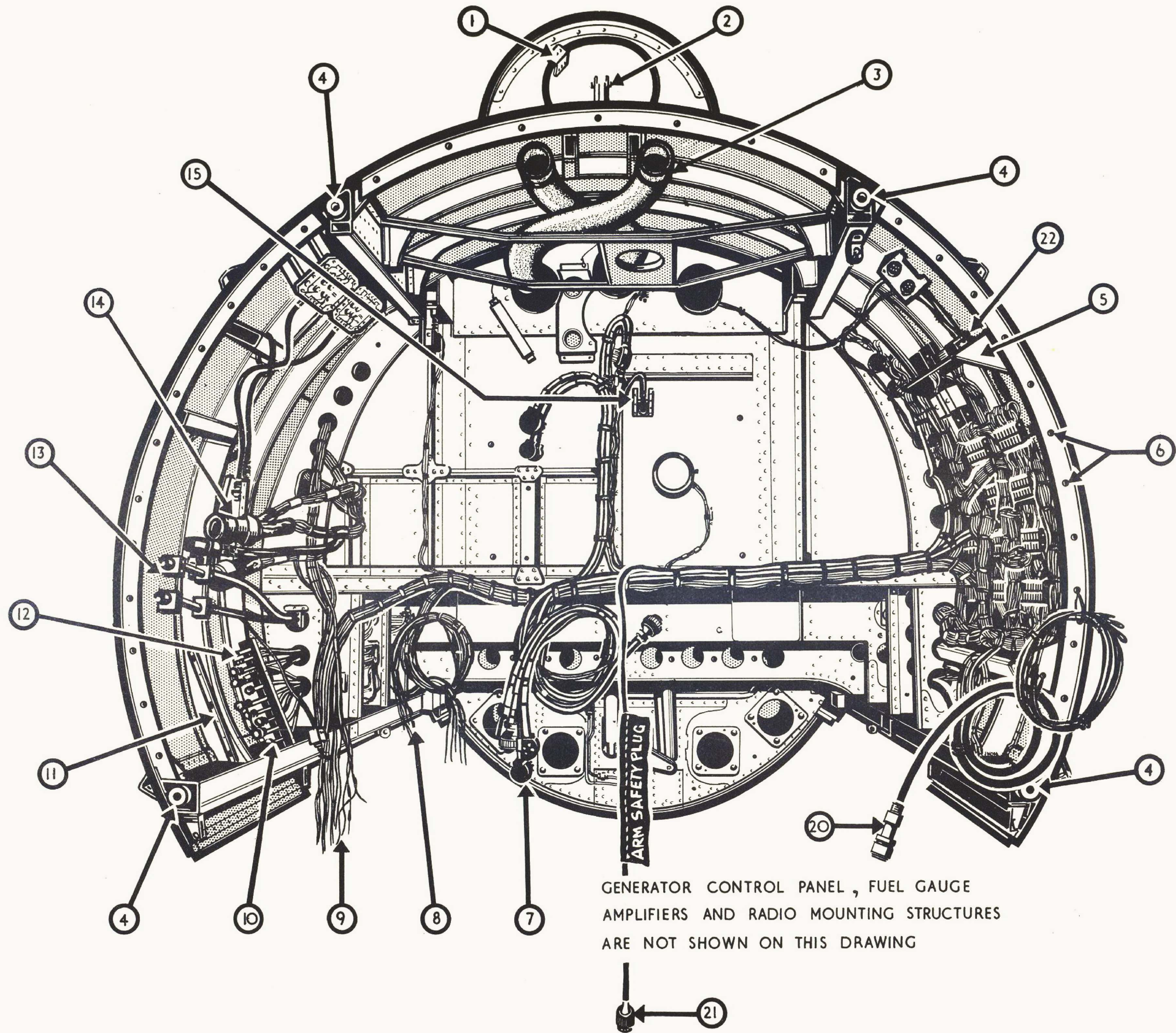

FIG 10 - REMOVING FRONT FUSELAGE (1)

REMOVAL OF FRONT FROM CENTRE FUSELAGE (FIG. 10 AND 11)

Render the aircraft electrically safe (Sect.4, Chap.1, Pocket A.1)

Remove the gun package, Sect.7, Chap.3.

Jack and trestle the aircraft as shown in Sect.2, Chap.4, fig.4, with the exception of the front fuselage jack, but with the addition of the trestling for the front fuselage fig.6, and the centre fuselage fig.8.

Remove the aircraft batteries, Sect.2, Chap.2.

Remove radio and mounting structure, Sect.6, Chap.1 and 2.

Unclip and stow all radio cables and connectors which extend between the transport joints. The details are as follows:-

#### Front fuselage (fig.10)

Item (9) which includes two F.21 and one F.23 cables, type 200 inverter connector B22/20C/1.

Item (8) F.47 and F.48 cables, three connectors type B14/20B/2, B2/40F/1 and B8/10A/2 from the D.M.E. junction box.

Item (7) two V.H.F. control connectors and three I.F.F. control connectors.

Disconnect armament safety plug (21) from socket (15) and leave hanging with pennant on front fuselage.

#### Centre fuselage (fig.11)

Item (17) three V.H.F. control connectors.

#### Electrics

Disconnect cables C16, C18 and C20 from cables F16, F18 and F20 at the bracket on the port side of

frame 17 (fig.10). Unclip and stow C16, C18, and C20 with the centre fuselage (17). Remove F16, F18 and F20 from the same bracket; unclip and stow with the front fuselage (14) (fig.10).

Disconnect the compass cable G.C.3 from G.C.2 and C44 from F59 from a bracket above the top of the supply panel (5) fig.10. Unclip and stow with centre fuselage (5) fig.11.

Disconnect the jet pipe temperature cable F46 (22) at terminal block and stow with centre fuse.

Disconnect cables C1, C2 and C4 and C39 from the plugs at the bottom of the supply panel and stow with centre fuselage at (18).

Disconnect cable F46 from supply panel and stow with centre fuselage.

Disconnect cables C5, C37 and C38 from the generator control panel, unclip and stow with centre fuselage (18).

Disconnect cables CR30, CR65, CRC146, CR154, CR228 and CR192 from the fuel gauge connector boxes, unclip and stow with the centre fuselage (17)

Disconnect jet pipe temperature cable (22) from terminal block on supply panel.

Disconnect cable A7 (20) fig.10 from Armament J.B1 (19) fig.11 centre fuselage. Unclip and stow with front fuselage.

#### Hydraulics

Disperse pressure in the system and drain (Sect.3, Chap.6).

Remove the centre cleat from the bracket (11) fig.10 together with the aft cleat adjacent to the transport joint.

Remove the locking wire and unscrew the eight unions (10) on the front fuselage, and the locking wire and eight unions on the centre fuselage.

Remove the centre portions of the pipes.

Blank off the pipe ends to prevent the ingress of dirt and swarf.

#### Pressure head pipes

Remove the locking wire and the two unions (12) on the pressure air pipes at both the front fuselage and the centre fuselage removing the centre portion of the pipes.

Blank off the pipe ends to prevent the ingress of dirt and swarf.

#### Engine controls

Unscrew and disconnect the two Teleflex controls (13) after removing the twelve 2 BA bolts and anchor nuts from the Teleflex (13) control covers, remove the covers from the fuselage brackets.

#### Flying controls

Remove the detachable hood fairing at the forward section of the spine Sect.2, Chap.4, fig.2, by removing the attachment screws. Break down the flying controls (2) by removing the six bolts and split pins.

Unclip, as necessary, the I.F.F. aerial connection and withdraw it through a hole in the top of the fuselage under the spine, just forward of the transport joint. Disconnect the cable at bracket (1) fig.10, coil and stow with the centre fuselage.

Disconnect the union (16) on the air conditioning pipe.

Uncouple the hot and cold pipes (3) of the cabin heating system by removing the bonding tabs and clips. These pipes should be tied up to support their weight, to avoid breakage at the forward end.

Remove the wing stub fairings.

Remove the four forward external retaining nuts and split pins securing the stub wing nosing to the front fuselage.

Remove the four screws, streamline distance pieces and anchor nuts from the boundary layer ducts in the air intakes.

Attach the slinging gear and bracing struts to the front fuselage (fig.6), and take the weight.

Remove the 31 split pins and nuts (6) attaching the front fuselage to the centre fuselage.

Remove the 18 s.w.g. locking wire and, unscrew the four longeron bolts (4) by using a cranked spanner.

The front fuselage may now be slung clear complete with trestles.

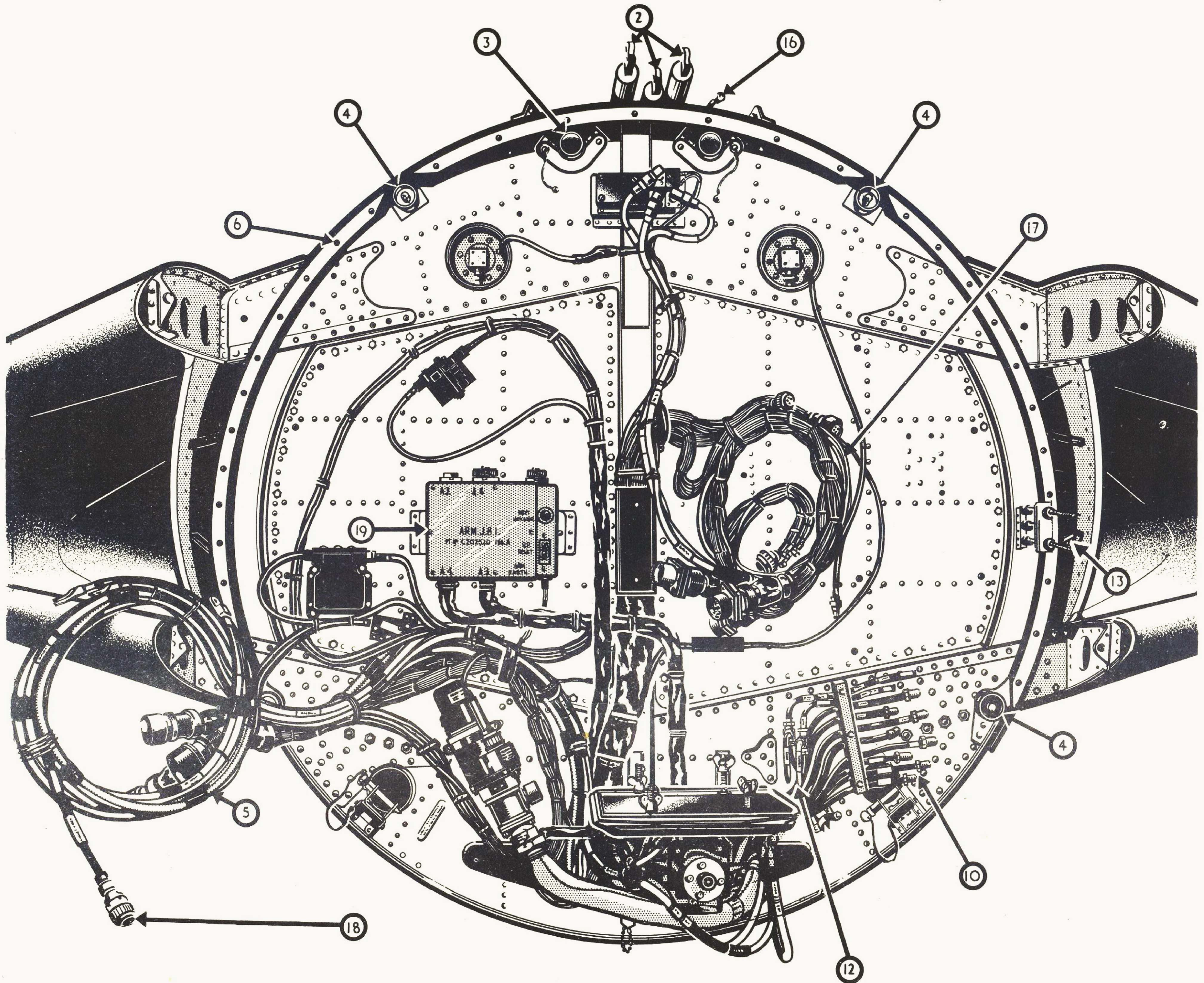

FIG 11 - REMOVING FRONT FUSELAGE (2)

## REMOVAL OF REAR FUSELAGE

Trestle the aircraft, except rear fuselage, as shown in Sect.2, Chap.4, Fig.4 with additional trestles under the centre fuselage (fig.7) and a trolley under the rear fuselage (fig.8).

Render the aircraft electrically safe as described in Sect.5, Chap.1.

If the tail unit is to be removed, refer to Sect.3, Chap.3.

Drain the fuel system as described in Sect.2, Chap.2.

Dissipate hydraulic pressure and drain the system as described in Sect.3, Chap.6.

Pull out the spring loaded bearing cooling outlet pipe (17) and turn to engage the retaining pin against the skin plating.

Pull out the engine drain pipe (18) and turn anti-clockwise to engage in retaining slot.

Remove the port and starboard access doors to the jet pipe coupling. Unfasten the access doors (12) on the engine casing and loosen the stirrup nut (14), raise the stirrup (11) and slide the Keeper plate (13) downwards to release.

Close the engine casing doors (12).

Lash the airbrake flap securely to fuselage.

Remove the detachable spine above the rear transport joint.

Disconnect the flying control rods (5) and (6).

Disconnect the hydraulic self-sealing couplings (9) (10). Remove the blanking caps (4) (7) from their stowage points on the rear fuselage.

Stow the couplings (9) (10) on the points from which the blanking caps have been removed. Assemble the blanking caps on the couplings in the centre fuselage.

Remove the rear transport joint butt strap (1)

Turn off the fuel gate valve (22) at the bottom of the transport joint and disconnect the fuel pipes (3) (8) in the spine.

Disconnect the aerial cable coupling (2) in the spine.

Disconnect the compass cable G.C.9 (27) in the spine.

Disconnect the fuel pipes (21) (23) at the bottom of the transport joint.

Disconnect the three electric cables R1 (24), R2 (25), R3 (21) and the radio cable T.S.4 (19) in the lowest part of the transport joint.

Disconnect the airbrake hydraulic self sealing couplings (26)(port and starboard).

Disconnect the fuel tank connections (16) port and starboard.

Check to ensure that the rear fuselage is adequately supported. Loosen the nuts (15) securing the centre and rear fuselage. The nuts should be undone in opposite pairs and not one by one all the way round.

The rear fuselage is now free of the engine and centre fuselage and may be carefully withdrawn.

#### ASSEMBLY

#### NOTE...

Whenever the rear fuselage is removed, and prior to the assembly of the rear fuselage to the centre fuselage, the attachment spigots (Ref. No. 26FX/721, Part No. F.181010) should be checked for tightness, using the special tool (Ref. No. 26FX/95223, Part No. B.200521). Any re-tightening of spigots found

necessary will necessitate re-peening of the spigot securing nut.

When assembling the rear fuselage, ensure that the chains of the blanking caps (3) and (6) pass under the trunnion bolt of the butt strap (1).

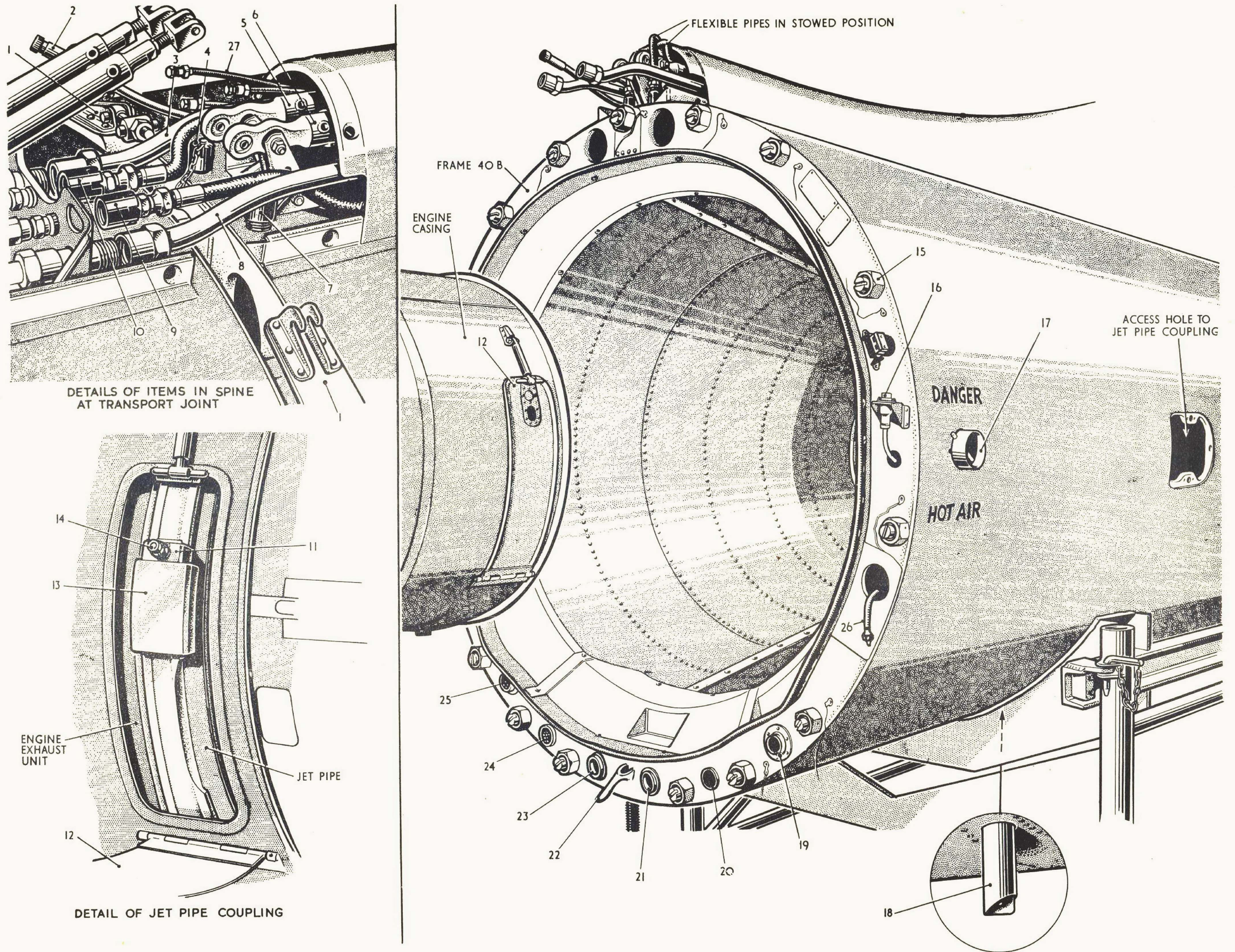
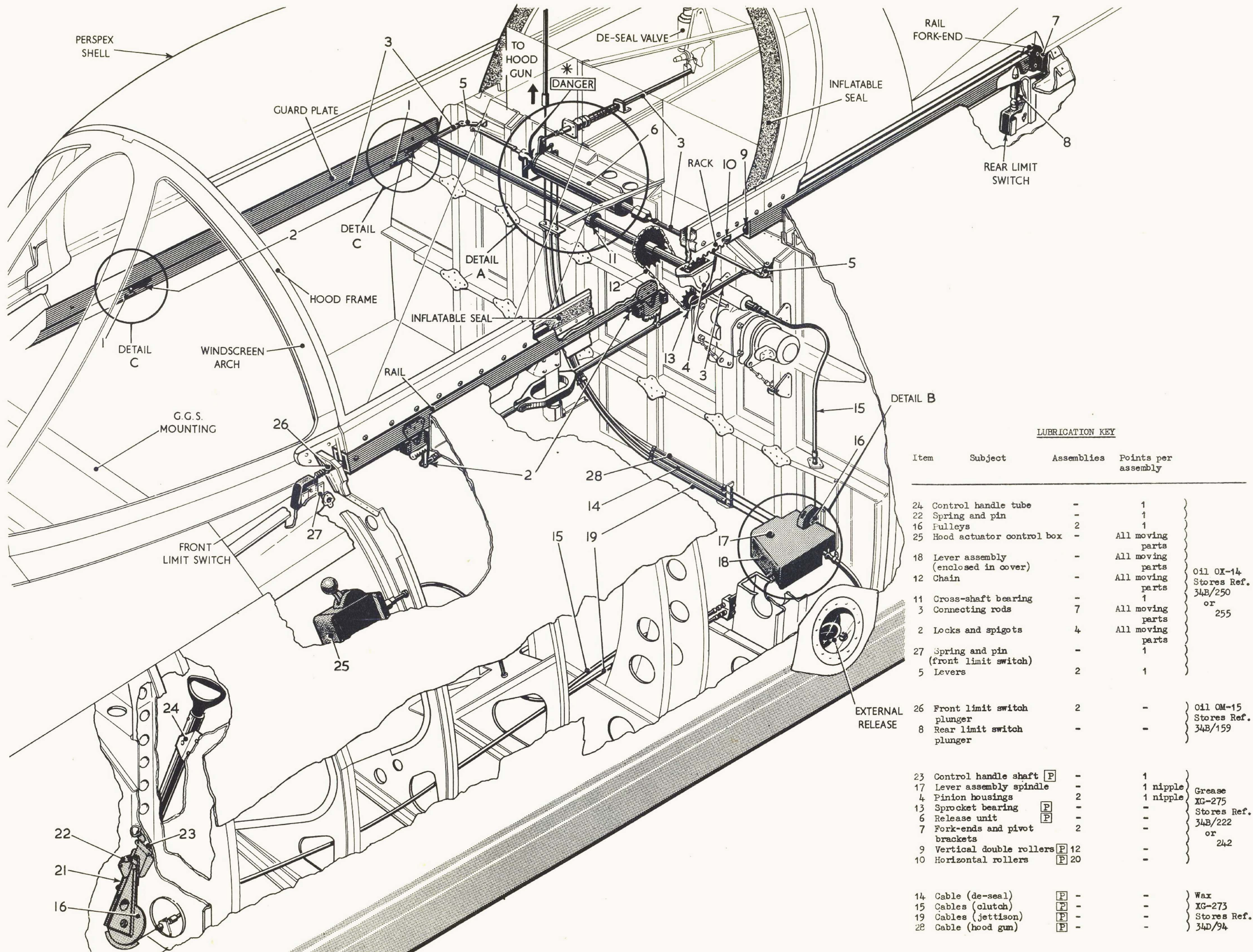

FIG. 12 REMOVING REAR FUSELAGE



LUBRICATION KEY

Item	Subject	Assemblies	Points per assembly	
24	Control handle tube	-	1	} Oil OX-14 Stores Ref. 34B/250 or 255
22	Spring and pin	-	1	
16	Fulleys	2	1	
25	Hood actuator control box	-	All moving parts	
18	Lever assembly (enclosed in cover)	-	All moving parts	
12	Chain	-	All moving parts	
11	Cross-shaft bearing	-	1	
3	Connecting rods	7	All moving parts	
2	Locks and spigots	4	All moving parts	
27	Spring and pin (front limit switch)	-	1	
5	Levers	2	1	} Oil OM-15 Stores Ref. 34B/159
26	Front limit switch plunger	2	-	
8	Rear limit switch plunger	-	-	
23	Control handle shaft [P]	-	1	} Grease XG-275 Stores Ref. 34B/222 or 242
17	Lever assembly spindle	-	1 nipple	
4	Pinion housings	2	1 nipple	
13	Sprocket bearing [P]	-	-	
6	Release unit [P]	-	-	
7	Fork-ends and pivot brackets	2	-	
9	Vertical double rollers [P]	12	-	
10	Horizontal rollers [P]	20	-	
14	Cable (de-seal)	[P] -	-	} Wax XG-273 Stores Ref. 34D/94
15	Cables (clutch)	[P] -	-	
19	Cables (jettison)	[P] -	-	
28	Cable (hood gun)	[P] -	-	

[P] ..... Prepacked

FIG. 13 SLIDING HOOD, JETTISON MECHANISM AND CONTROLS (1)

## REMOVING SLIDING HOOD (FIG.13 AND 14)

## WARNING...

Before attempting to enter the cabin, report to the N.C.O. immediately I/C of aircraft servicing, who will ensure that the ejection seat and hood guns are safe for the purpose required.

Full instructions for rendering the seat safe are contained in the A.P.4288 series, in A.D.5037, and in the A.D.6038 series.

To remove the sliding hood, together with the rails, and without operating the jettison mechanism, proceed as follows:-

Render the aircraft safe electrically in accordance with the instructions in Sect.5, Chap.1, Group A.1.

Wedge the four lock sears (2) rearwards to free the locks.

Without handling the perspex shell and taking care not to allow the hood to run on the rails and avoid damage to the inflatable seal or rail housings, raise the hood and rails at the forward end approximately 25 deg. to disengage the rail fork-ends from the pivot brackets (7) and lift clear of the structure.

## ASSEMBLING SLIDING HOOD

## NOTE...

Check that the rollers (9) and (10), the rack, the lock spigots (2) and the fork-ends and pivot brackets (7) are lubricated as necessary to prevent corrosion.

Render the aircraft electrically safe and reverse the procedure for "Removing sliding hood" taking care that the inflatable seal is not crushed as the rails descend into the structure. When refitting the hood, the following procedure should be adopted:-

- (1) Ensure that the hood rails are correctly

engaged at the rear end as far aft as possible before lowering the assembly to engage the rail spigots in the locks, thus avoiding damage to the lock housings.

- (2) When the hood/rail assembly has been fitted to the aircraft, and before closing the locks, de-clutch the hood motor and move the hood to the forward position. Lift the hood slightly so that the racks on the hood are clear of the drive pinions, then push the hood forward to contact the windscreen frame. This will ensure that when the hood is lowered again, the rack on each side will engage correctly with the pinions and will not be one tooth out on one side, as can happen if this procedure is not adopted.

## HOOD WINDING ADJUSTMENTS

Adjust the tappet bolt (26) so that the sliding hood comes to rest within 0.03 in. max. of the hood fully forward position when power operated.

Push the hood rearward until the tail end of the rack meets the inner face of the rail fork-end, then move the hood forward leaving a gap of 0.35 in. to 0.50 in. and set the rear limit switch to just contact the plunger (8) and tighten the switch in place.

Finally check the functioning of the electrically-operated hood winding system.

## RESETTING HOOD JETTISON MECHANISM

## WARNING...

When the jettison mechanism is set, the hood is fully operative in conjunction with the ejection seat mechanism as described in Sect.1, Chap.3.

Lift the thumb latch (21) and return the pilot's

control handle (24) to its socket.

Check that the gyro gun sight switch (22) and its operating lever are correctly set.

Ensure that the external release is pulled back into the fuselage. Replace window. Check that the aircraft is electrically safe (Sect.5, Chap.1, Group A.1).

WARNING...

The release unit (6) shown both loaded and unloaded (Fig.14 Detail A) is loaded when the spindle (40) is extended fully to the port side and the jettison lever (36) is  $22\frac{1}{2}$  deg. above the horizontal.

After ensuring that the release unit is not loaded, check that the connecting rod (34) has a free travel of 0.60 in. to 0.70 in. and if re-adjustment is necessary proceed as follows:-

Remove pin (32)

With the de-seal lever (35) touching the jettison lever striking pin (33) in the unloaded position, push the connecting rod (34) fully rearwards and align it with the de-seal lever (35) so that the pin holes coincide.

Shorten the rod by one turn and re-insert the pin (32) then tighten the lock nut (31).

Finally check the free travel mentioned above has been obtained. Rotate coupling (39) and hold the release nut (38) until it enters the 'H' hole (37) and is flush with the outer face of the lever 36. If the lever (36) will not now turn to the loaded position, rotate

the coupling further until the lever can be freely moved to the loaded position. No further rotation of the coupling in this direction is permissible. Lock the release nut (38) into the end plug (41) by pulling the lever (36) upwards 45 deg.

NOTE...

It is important that this lever (36) is retained in this position throughout the resetting operations to prevent accidental release and possible serious injury.

Load the unit by rotating the coupling (39) clockwise (looking from starboard) to the full extent of its travel, then slacken off half a turn.

Remove the cover (18) detail B and check the setting of the levers (43) and (44) as follows:-

With lever (43) detail B set .45 in. to .35 in. from the face of port outboard stiffener on frame 14, check for adjustment the clutch cables 15 and the de-seal cable (14) fig.13.

With the lever (44), set with the centre of the pin securing the clutch control cable to the lever set 3.0 in. to 2.90 in. from face of frame 14, check for adjustment the two jettison cables (19) fig.13.

Replace cover 18

Check that the lock sear pins (2) detail C are in the locked position (i.e. forward) and that the four indicators (1) are correctly set.

The mechanism is now ready for operation.

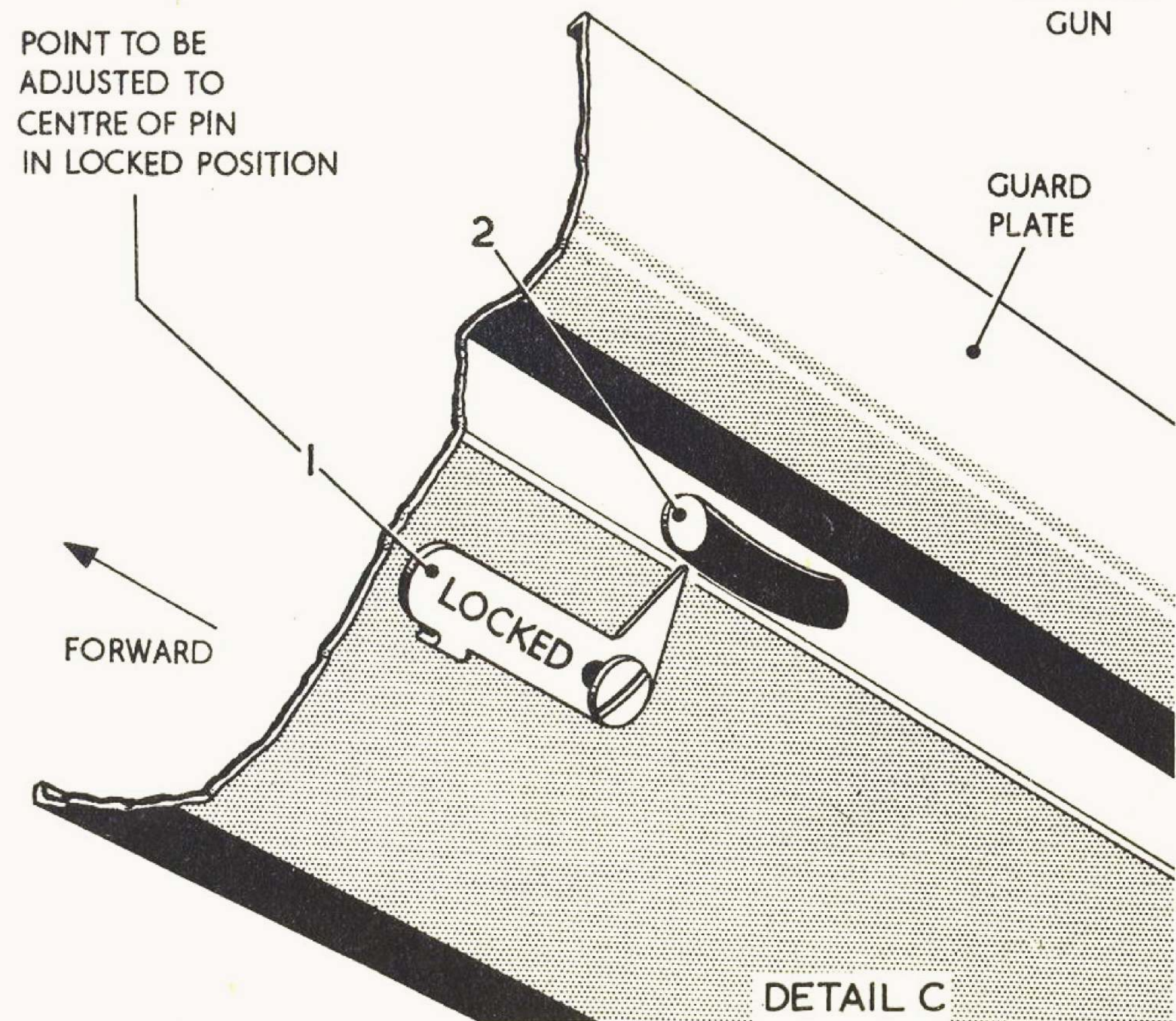
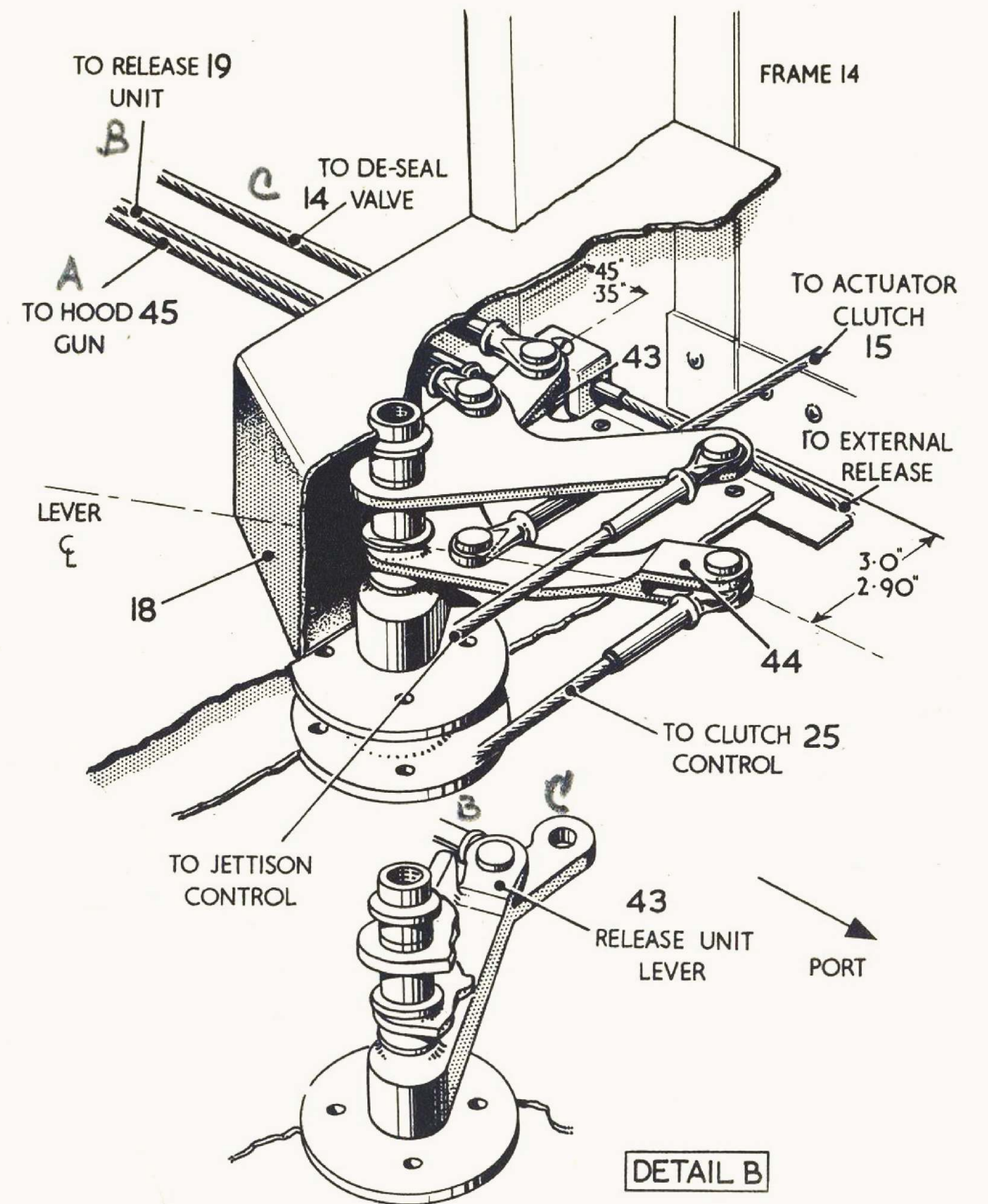
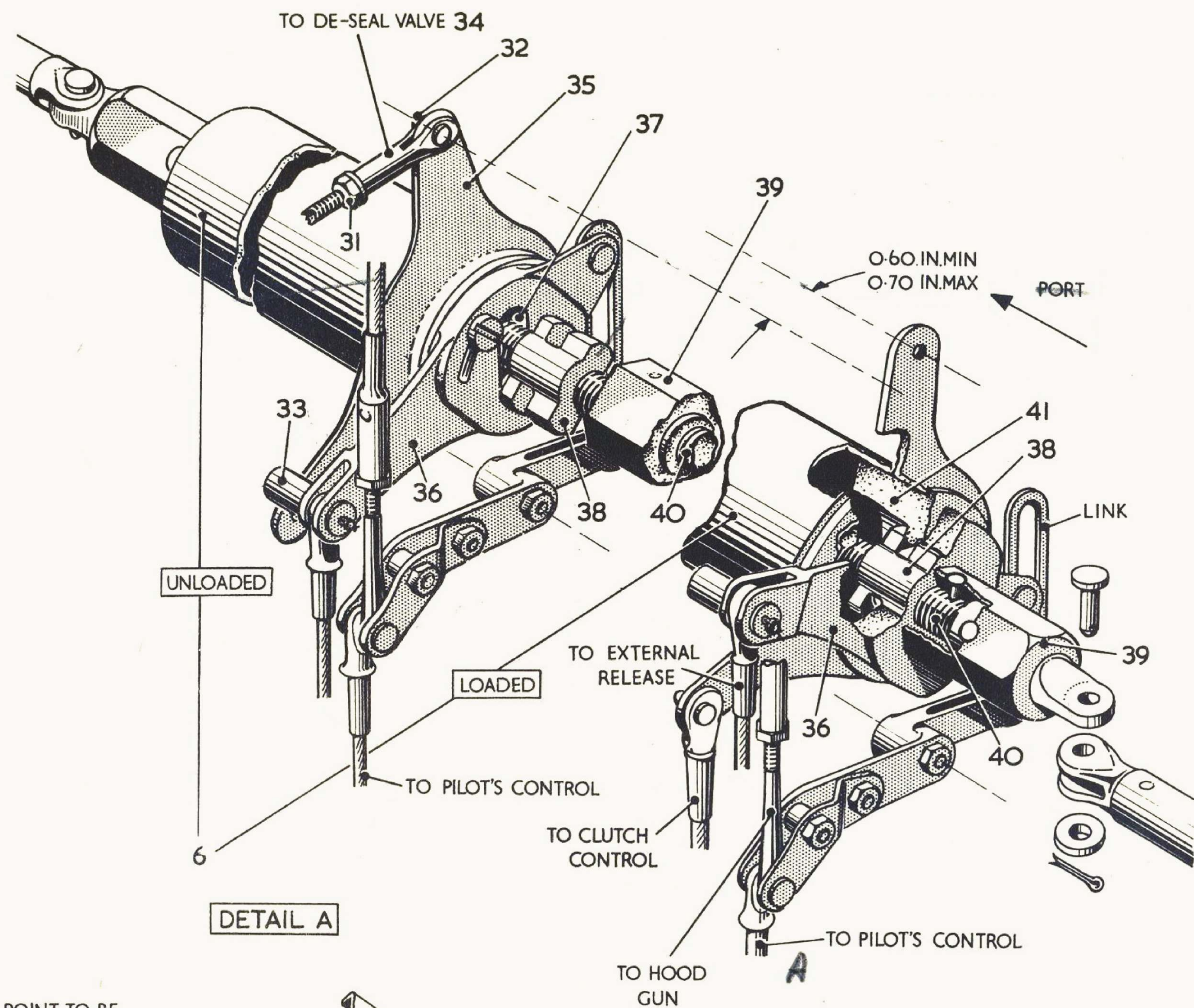
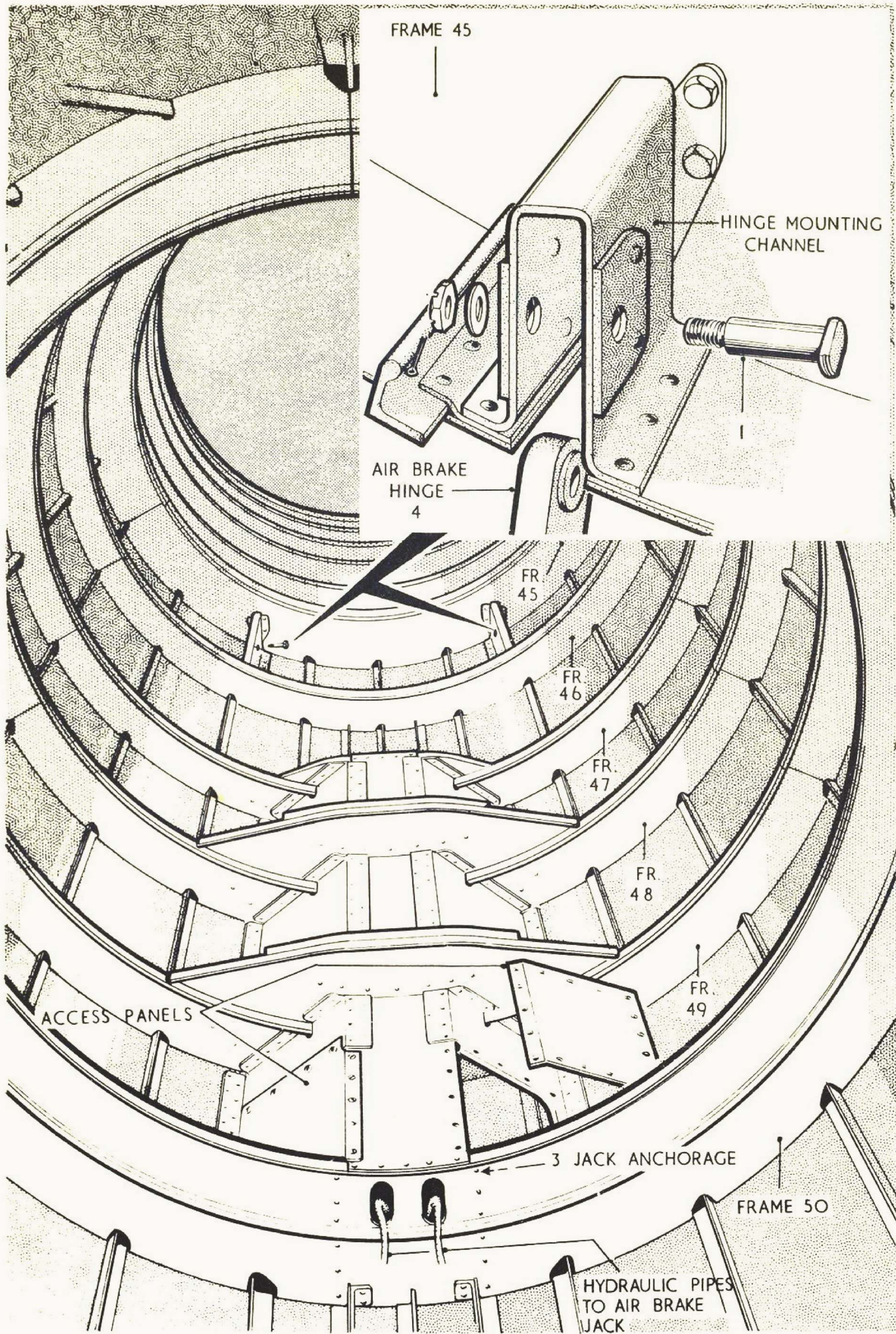
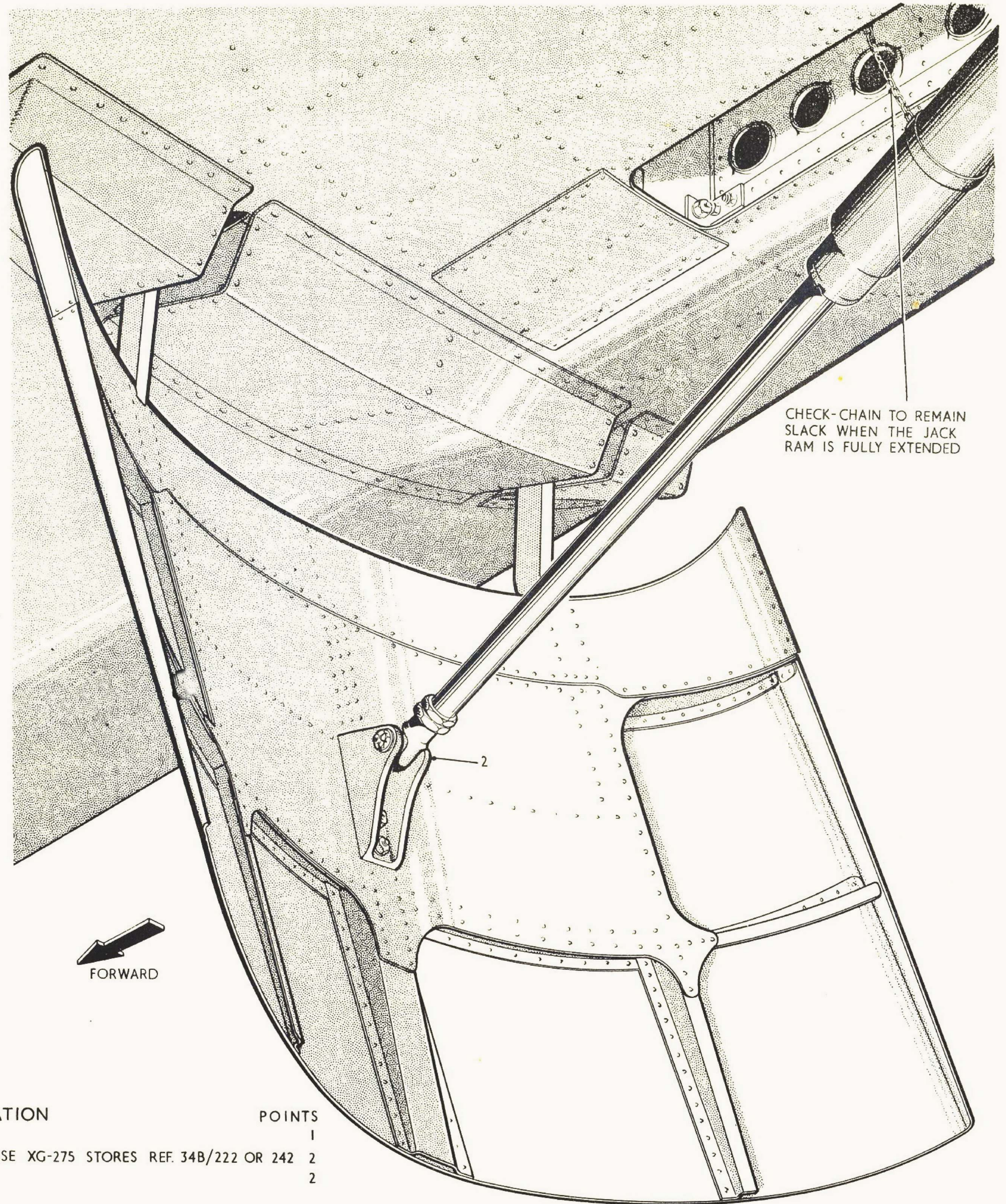

FIG. 14 SLIDING HOOD, JETTISON MECHANISM AND CONTROLS (2)



DETAIL OF AIR BRAKE JACK HOUSING STRUCTURE AND HINGE MOUNTING



LUBRICATION

2	} GREASE XG-275 STORES REF. 34B/222 OR 242	1
3		2
4		2

POINTS

FIG.15 REMOVING AIR BRAKE

REMOVING AIR BRAKE (Fig.15)

Jack up the aircraft as described in Sect.2, Chap.4 and retract the undercarriage.

After ensuring that the area below the air brake is free from obstruction, select air brake out by operation of the control on the throttle twist grip and operate the handpump until the air brake is fully extended.

Select air brake in to release the hydraulic pressure from the jack.

Check that the check chain is securely attached to the aircraft structure and the jack body.

Render the aircraft electrically safe as described in Sect.5, Chap.1.

Remove the jet pipe as described in Sect.4, Chap.1.

Remove the split pin, slotted nut and washer from the pivot bolt (2) and withdraw the bolt.

Support the air brake and from the inside of the rear fuselage remove the two pivot bolts (1). The air brake can now be removed.

ASSEMBLY

After assembly of an air brake, adjustment of the jack is to be carried out as described in Section 3, Chap.4.

This file was downloaded  
from the RTFM Library.  
Link: [www.scottbouch.com/rtfm](http://www.scottbouch.com/rtfm)

Please see site for usage terms,  
and more aircraft documents.

