

## CHAPTER 8

## AIR CONDITIONING SYSTEM

## LIST OF CONTENTS

	<u>Para.</u>		<u>Para.</u>
DESCRIPTION AND OPERATION		Ground test connections . . . . .	17
Introduction . . . . .	1	<b>SERVICING</b>	
Engine air pressure system . . . . .	2	Cold air unit - servicing prior to	
Ram air supply . . . . .	6	installation . . . . .	18
Temperature control . . . . .	7	Cold air unit - precautions . . . . .	19
Hood seal . . . . .	8	Drains . . . . .	20
Cabin air extraction valve . . . . .	9	<b>MAINTENANCE OF CABIN PRESSURE AND STRUCTURAL</b>	
Temperature control valve . . . . .	10	<b>SEALING</b>	
Air supply valve . . . . .	11	Sealing cabin structure . . . . .	21
Pre-cooler by-pass valve . . . . .	12	Application of sealants . . . . .	22
Variable orifice valve . . . . .	13	Cabin pressure tests . . . . .	23
Auxiliary cabin air discharge valve . . . . .	14	<b>ASSEMBLY OF COMPONENTS</b>	
Controls . . . . .	15	Air supply valve and temperature control valve	24
Visual warning of loss of cabin pressure . . . . .	16	Cabin air extraction valve . . . . .	25

## LIST OF ILLUSTRATIONS

	<u>Fig.</u>		<u>Fig.</u>
Cabin air extraction valve . . . . .	1	Air conditioning installation (1) . . . . .	6
Temperature control valve . . . . .	2	Air conditioning installation (2) . . . . .	7
Air supply valve . . . . .	3	Air conditioning diagram (1) . . . . .	8
Pre-cooler by-pass valve . . . . .	4	Air conditioning diagram (2) . . . . .	9
Variable orifice valve . . . . .	5		

RESTRICTED

## DESCRIPTION AND OPERATION

### Introduction

1. The Hunter aircraft is provided with a pressurised cabin, pressure air being obtained from a restricted tapping on the engine compressor. A switch in the cabin is provided to select pressurisation, the 'OFF' position enabling ram air, obtained from an air scoop in the nose of the aircraft, to be used in lieu of engine air pressure if desired, and automatically under certain conditions of flight. Temperature control is effected by means of a temperature control switch, which is gated for 'HOT' or 'COLD' air selection in manual with an intermediate position to maintain the selected condition. A fourth position provides for control in auto. The cabin hood is provided with a rubber seal which is automatically inflated when the hood is closed and deflated automatically when 'HOOD OPEN' is selected, partial deflation occurring before the hood actuation gear operates.

### Engine air pressure system

2. Air supply for cabin pressurisation is taken from a restricted tapping on the final stage of the engine compressor. From this tapping, the air passes to a pre-cooler situated on the port side of the fuselage between frames 27 and 31. A by-pass valve (para.12) piped to the air supply and pre-cooler permits the air to by-pass the pre-cooler under certain conditions of flight. From the pre-cooler, which reduces the temperature of the air to a permissible value, the air passes to a motorised air supply valve (para.11) for normal air supply, or, under certain conditions, for flood (para.4). For normal (or main) feed, the air leaves this valve to continue to a variable orifice type mass flow

controller which has two outlets, one conveying the hot air to the cockpit through the temperature control valve (para.10) and the other passing the hot air to a turbo refrigerator. This unit consists of a free-running compressor and turbine on one shaft, with a ducted inter-cooler in between. When air supply valve 'ON' is selected, the air passes to the compressor and thence via the inter-cooler to the turbine. The output from the turbine is piped to the cockpit. The hot and cold airstreams rejoin at a mixing chamber downstream of the refrigerator unit and the combined flow is delivered via a water separator and thence via a non-return valve to the cockpit ventilation galleries. These galleries feed sprays at the windscreen, quarter lights and at the sides of the hood.

3. Spent ventilation air is expelled from the cabin via a cabin air discharge valve, mounted on the forward face of frame 6. The outlet from this valve is shrouded. Piping in the nose of the aircraft, downstream of this shroud, permits the waste air to circulate in jackets around the radar equipment for cooling purposes before it is finally discharged to atmosphere in the nose of the aircraft.

4. Flood air from the motorized air supply valve is fed into the refrigerator outlet duct. This feed is obtained automatically whenever the cabin altitude exceeds 38,000 ft. by the operation of an altitude switch (Sect.5, Chap.1, Group D.6) which opens the air supply valve to the FLOOD position to prevent a low cabin pressure occurring at this altitude. Flood air may also be obtained manually to provide hot air for demisting purposes, by placing the flood switch in the manual position.

5. A type A cabin pressure controller, which

operates the cabin air discharge valve, commences pressurisation at 10,000 feet and the full  $3\frac{1}{2}$  lb. per sq.in. differential is built up at 25,000 feet and above. For a description of the pressure controller, reference should be made to A.P.1275A, Vol.1, Sect.10, Chap.3.

#### Ram air supply

6. An alternative air supply for emergency cabin air ventilation is provided from a forward facing air scoop situated in the camera vision cone in the nose of the aircraft. From the scoop, the air passes through a pneumatically-operated ram air shut-off valve mounted on frame 6 and thence into the cabin. In circumstances which entail positive isolation of the engine air pressurisation supply, ram air induction is further assisted by a pneumatically operated extractor valve, mounted on the forward face of frame 14, which operates in conjunction with the ram air shut-off valve and directs outflow of spent air to a region of low pressure. This condition is obtained by operating the 'Cabin Pressure' on/off switch, thus causing the air supply valve to close and the extractor valve to open. The hood seal is kept inflated to prevent the noise of air leakage at the joints.

#### Temperature control

7. The cabin temperature can be automatically controlled to within  $\pm 2\frac{1}{2}$  deg.C at any selection in the range of +5 deg.C to +30 deg.C. This is effected by means of the type FLM/A/1 electronic cabin temperature controller. The unit consists of a wheatstone bridge network, wherein the selected temperature (equivalent resistance) and the actual cabin temperature are compared. The error signal current arising from

their difference is amplified by means of a pair of transducers (saturated transformers). The amplified and rectified A.C. output is then made to actuate one of a pair of electrically inter-locked relays according to the direction of the wheatstone bridge unbalance. This supplies D.C. current to the appropriate side of the split field series actuator operating the temperature control valve (para.10) and the actuator moves, carrying with it the sliding contact of the re-setting potentiometer. This movement continues until the follow-up potentiometer re-sets the wheatstone bridge network at the new equilibrium datum when the error current is cancelled and the relay contacts drop out. In this manner, progressive alterations in temperature control valve opening are timed to damp out or suppress deviations in cabin temperature from selected settings.

#### Hood seal

8. A pneumatic rubber seal is provided around the perimeter of the cabin hood joint. A common supply for the seal and extractor valve is taken from a tapping just downstream of the pre-cooler. A combination of reducing valve and non-return valve, with a safety blow-off, maintains the air supply to the seal at a pressure of 8 lb. per sq.in. above cabin datum pressure. The supply branches off via solenoid valves to the hood seal and extractor. On deflation, the exhaust is bled to atmosphere. The closing of the main pressure air supply valve does not affect the seal. The hood seal solenoid valve, which is provided with a mechanical override, ensures that the hood seal is inflated when the hood is closed and remains inflated if the electrical power fails. The hood seal solenoid and hood winding motor are activated from a common control switch. The seal is inflated when the solenoid is de-energised. The

circuit incorporates a time-delay to achieve deflation of the hood seal before the hood commences to open. The solenoid also incorporates a mechanical override, which operating in conjunction with the hood jettison gear, provides for hood seal deflation prior to jettisoning the hood. (It is recommended that the 'Cabin Pressure' switch is operated to 'Press Off' before jettisoning the hood).

#### Cabin air extraction valve (fig.1)

9. The cabin air extraction valve is fitted on frame 14. It is operated pneumatically via a solenoid from the main engine pressure supply and is automatically opened when the main air supply valve is closed. If the electrical power fails, the extraction valve remains closed. The valve operates in conjunction with the ram air shut-off valve (para.6).

#### Temperature control valve (Fig.2)

10. The temperature control valve consists of a valve body (A) which contains a spindle which carries the operating levers (C) which in turn engage with the split sleeve (D). The sleeve contains a specially shaped port which gives a progressive opening of the valve. The actuator (B) is arranged to engage with the valve spindle for operation of the valve. A pinion on the valve spindle engages with a separately mounted quadrant which in turn operates, through a linkage, a follow-up resistor which is part of the temperature controller.

#### Air supply valve (Fig.3)

11. This valve is similar in construction to the temperature control valve (para.10), except that an

additional outlet port is provided for flood air. It is operated by an actuator which is itself operated by the pilot's control in the cabin for 'PRESSURE ON' or 'PRESSURE OFF' and by an altitude switch for flood air. A manual switch in the cabin enables the pilot to select flood air as desired.

#### Pre-cooler by-pass valve (Fig.4)

12. This valve consists of a body (A) which contains a spring-loaded sliding valve (D). The valve body contains two inlet ports, one of which, (port B), is connected to a pipe from the pre-cooler and the other, (port C), to a pipe which by-passes the pre-cooler. There is a common outlet port (E). According to the position of the sliding valve (D) the pressure air is either fed into the system direct or is passed through the pre-cooler. The position of the valve is dependent on the pressure difference at the two ends of the valve body, one end being connected to the hot air by-pass pipe from the variable orifice valve (para.13) and the other to the cold-air outlet from the refrigerator unit. When the temperature control valve is closed, the pressure in the hot air-by-pass is high and hence the by-pass valve passes air through the pre-cooler.

#### Variable orifice valve (Fig.5)

13. The variable orifice valve consists of a body (A) which contains a sliding spring-loaded valve (C). Its purpose is to control the flow of air to the cold air unit or direct to the cabin through the hot air by-pass. Movement of the valve is effected by the pressure difference across it, the profile of the valve being forced into a circular orifice in order to provide the required flow. The inlet port (D) is in connection with the normal outlet port of the air

supply valve, the outlet port (E) with the hot air by-pass and the outlet port (B) with the inlet of the cold air unit.

#### Auxiliary cabin air discharge valve (fig.6)

14. The auxiliary cabin air discharge valve is in the hood fairing. With the cabin pressure ON, the rear discharge valve is normally shut by venting its control chamber through the solenoid valve to the cabin. Selection of flood air manually for de-misting connects the control chamber through the solenoid valve to the Type A controller. Front and rear discharge valves then operate in parallel to dispose of cabin air.

#### Controls

15. Cabin pressurisation is controlled from an ON/OFF pressurisation control switch which is situated on the rear portion of the cabin port shelf. A flood switch marked AUTO/MANUAL is mounted on the same shelf. An auto/manual temperature control switch, mounted adjacent to the pressure control switch, is marked AUTO, COLD and HOT. The pressurisation control switch controls the air supply valve actuator located on frame 33, the air extractor valve solenoid situated on frame 14 and the temperature control valve actuator in the hood fairing. The flood switch also controls the air supply valve actuator to give manual control of flood operation irrespective of the aircraft's altitude. The intermediate positions of the temperature control switch are used to maintain the temperature control valve in any chosen condition. When the temperature control switch is placed at 'auto', temperature is selected by means of a temperature selector mounted on the cabin port shelf. The selected temperature is then automatically maintained by the type FLM/A/1 electronic cabin temperature controller. The

magnetic amplifier and cabin element of the controller are located in the cabin and the follow-up resistor in the hood fairing adjacent to the temperature control valve actuator. Provision is made for overriding the pressurization control switch to close the air supply valve and energize the air extractor valve solenoid to open the valve when 'HOOD OPEN' is selected. At the same time the hot air by-pass is closed. For further information on the operation, electrical inter-connection, relays etc., reference should be made to Sect.5, Chap.1, Group D.6.

#### Visual warning of loss of cabin pressure

16. Warning of loss of cabin pressure is given visually by means of a warning lamp located on the starboard instrument panel in the cabin. The warning lamp is operated on contacting of the switch in the Type A controller mounted on the rear face of frame 6 whenever the cabin pressure differential falls by  $\frac{1}{2}$  - 1 lb. per sq.in. below nominal datum. A test switch, located on the rear portion of the cabin port shelf, is provided to test the warning light and flood circuits. For further information on the warning system, reference should be made to Sect.5, Chap.1, Group D.6 of this volume.

#### Ground test connections

17. Provision is made for ground testing the system, using an external supply. The equipment consists of the following:-

- (1) A connection for ground pressurisation of the cabin and a switch for external operation of the sliding hood, both of which are mounted on the forward face of frame 3. These are accessible after

removing the nose piece of the aircraft which is secured by fasteners (Sect.3, Chap.1, Fig.9).

- (2) A connection for hood seal inflation from an external source and a connection for a pressure gauge, both of which are on the forward face of frame 6 and are accessible via the nose wheel bay.

#### WARNING

Only personnel certified by the Station or Unit Medical Officer as fit for servicing duties inside pressure cabins are permitted inside the aircraft when tests are carried out at ground level. Personnel with colds must have further medical approval (A.P. 1464D, Vol.2, Part 1, Leaflet 36 refers).

#### SERVICING

#### WARNING

The detachable hood fairing (item 6 of fig.2, Sect.2, Chap.4) must be fitted at all times when ground pressurisation tests are being carried out.

#### Cold air unit - servicing prior to installation

18. At all times care must be taken to exclude dirt, oil or foreign matter from entry into this unit. Prior to installation all connecting pipe flanges should be examined for damage and distortion, and it should be ensured that they are clean and free from obstruction and oil. If the unit has been inoperative for an appreciable time, e.g., as in storage, it should be primed as detailed in A.P.4340, Vol.1, Sect.2, Chap.4.

#### Cold air unit - precautions

19. When the unit is subsequently serviced on the aircraft it should be topped up daily as described in Sect.2, Chap.2 of this volume. The oil and containers must be absolutely clean. Avoid overfilling the unit as excess oil may seep past the labyrinth seals when the unit is stationary.

#### Drains

20. The water separator is provided with a restricted drain which terminates outside the fuselage skin between frames 14 and 15 on the port side of the aircraft. The drain should be periodically examined to ensure that it is not blocked. The pre-cooler and inter-cooler are each provided with a drain pipe both of which terminate at the bottom of frame 30 and are accessible via the gearbox access door (Sect.2, Chap.4, item 102). The plugs sealing the drain pipes should be removed periodically and any water that may have collected should be drained off.

#### Maintenance of cabin pressure and structural sealing

#### Sealing cabin structure

21. The maintenance of cabin pressure at high altitude is essential and all sources of leakage must be sealed in accordance with the instructions given in the following paragraphs, using the approved materials listed below:-

- (1) Bostik pressurising plastic No.1751 (Stores Ref.33C/1139). This is a liquid used as a primer and sealant. It is applied with a brush.
- (2) Bostik pressurising plastic No.1790 (Stores Ref.33C/1138). This is a stopper extruded

RESTRICTED

from a tube, or pressure applicator, to form a bead around the edges of mating parts and for filling spaces too large for Bostik 1751.

- (3) Soft rubber rectangular strip (Commercial) or Prestik pressure plastic (Stores Ref.33C/889). This is for the preliminary filling of spaces too large for Bostik 1790.

NOTE...

As Bostik sealants are highly inflammable the unusual fire precautions for the application of inflammable materials must be observed.

Application of sealants

22. The method of application of the above sealants is as follows:-

- (1) Parts to be assembled or rectified for leakage should be coated with Bostik 1751 in the detail stage.
- (2) All joints in the pressure cabin must be sealed and, for an effective seal, the surfaces to be sealed must be scrupulously clean. If necessary, the surfaces to which the sealant is to be applied can be cleaned with white spirit, but the spirit must be used sparingly.
- (3) Make all the joints between mating parts. e.g., skin to frames, with Bostik 1751 applied with a 1 in. medium soft bristle brush, the application to extend for 3/8" from the joint in all directions on the pressure side of the joint. Allow between 30 and 60 minutes drying time before bringing the joint faces together. After riveting, apply a liberal coat of Bostik 1751 over all rivet heads. Dip bolts in Bostik 1751 before assembly. Coat any large apertures (above 0.10 in. approx. dia.) in corners

with Bostik 1751 and fill with Prestik Coated with Bostik 1751 immediately prior to insertion. Fill tooling holes with "Chekaleke" plugs applied as above. Fill pop rivets with Bostik 1790 and coat with Bostik 1751 on the pressure side. Allow to dry for 2 hours.

- (4) Apply a fillet of Bostik 1790 as necessary along the edges of mating parts and in jointed corners. Allow to dry for 24 hours.
- (5) Apply a further coat of Bostik 1751, extending over the whole area treated in sub-para. (3) above. Allow to dry for 24 hours before pressure testing.
- (6) Pressurize the cabin in accordance with the requirements laid down in para.23.
- (7) Stop any leaks shown in the above test with a further application of Bostik 1790 and 1751 over pressure side of the leak. Alternatively, a mixture of half and half of each, by volume, may be applied to the leak with a brush. Allow to dry for 6 hours before re-testing.
- (8) Allow 12 hours from the last application of sealant before painting.
- (9) Re-test in accordance with the requirements laid down in para.23.

NOTE...

Bostik 1790 may be thinned down by thinner Bostik 6846 if required. Experience has shown that a suitable mixture of Bostik 1790 and 1751 may be satisfactorily used in the pressure applicator and also applied with a brush. After

using the pressure applicator, accessories should be thoroughly cleaned with Bostik cleaner 6307 if they are likely to be out of use for a period in excess of 24 hours.

#### Cabin pressure tests

23. For this test, electrical feeds are required to the hood motor, extractor valve solenoid and hood seal solenoid. Also the cable for operating the hood externally should be plugged in. Other equipment needed is:-

- (a) Test Trolley Stores Ref. No.4F/1714
- (b) Canopy seal inflator (incorporating Schrader Valve) Stores Ref. No.4F/1812.
- (c) Connection adapter for cabin pressure gauge-2 off Stores Ref.No.4F/1810
- (d) Canopy seal pressure gauge-Stores Ref.No.6A/1582
- (e) Cabin pressure gauge - Stores Ref. No.6A/1582
- (f) Length of rubber hose to suit adapter (c)
- (g) Foot pump for hood seal inflation (car type)

The procedure for pressure testing the cabin is as follows:-

- (1) After preliminary adjustments of the hood seal micro-switch to cut in within the limits laid down (Sect.3, Chap.1, fig.13 and 14), and with the equipment listed above coupled to the aircraft, close the hood by means of the external switch, and gradually apply pressure with the foot pump to the hood seal and extractor valve. Note pressure at which extractor valve closes and continue pumping until seal pressure builds up to 8 lb. per sq.in. Check for leaks in the seal and extractor

valve system. (The cabin pressure switch must be in the 'ON' position).

- (2) Blank static vent of type 'A' controller and run test trolley with blow off set to produce a pressure of  $3\frac{1}{2}$  lb. per sq.in. in cabin. Trolley blow off setting should not be more than about 5 lb. per sq.in.

Carry out checks for leakages from various points, particularly the following:-

- (a) Cabin valves
- (b) Extractor valve
- (c) Cabin discharge valve
- (d) Access holes from flying controls, Teleflex controls etc.

- (3) Operate the various flying controls to make sure that their movement does not increase leakage.

In conclusion, check rate of cabin pressure fall. The required rate is for the pressure to drop from  $3\frac{1}{2}$  to  $1\frac{3}{4}$  lb. per sq.in. in not less than 1 min. *(1) 1.5 min. in reserve* after disconnecting the supply, with the hood seal pressure maintained at 8 lb. per sq.in.

At the end of these tests, unblank type 'A' controller static vent.

- (4) With the hood closed and cabin pressure 'ON' build up hood seal pressure to 8 lb. per sq.in. Disconnect foot pump and check that seal pressure does not fall below  $6\frac{1}{2}$  lb. per sq.in. over a period of 5 minutes.

At the ends of these tests disconnect the ground equipment.

#### ASSEMBLY OF COMPONENTS

Air supply valve and temperature control valve

24. The following should be observed when it becomes necessary to change either the actuator or the valve in any of the above assemblies.

- (1) When fitting the actuator to the valve, care should be taken to see that the actuator driving pin engages correctly with the valve spindle. The two components should slide together freely without force being applied to the driving spindle due to malalignment. Malalignment may cause damage to the actuator and increase the valve gland leakage.

- (2) With the valve closed apply an air pressure of about 75 lb. per sq.in, to the end inlet connection. This should be carried out before and after assembly to the actuator to check that gland leakage has not increased.
- (3) With a suitable breeze plug and switch connect the actuator to a 24 volt supply. With pressure applied open and close the valve over its full range by means of the actuator.

Cabin air extraction valve

25. When fitting a new cabin air extraction valve to frame 14, the mounting flange of the valve may be filed, locally, if necessary to enable it to clear the bend radius of the diaphragm of frame 14.

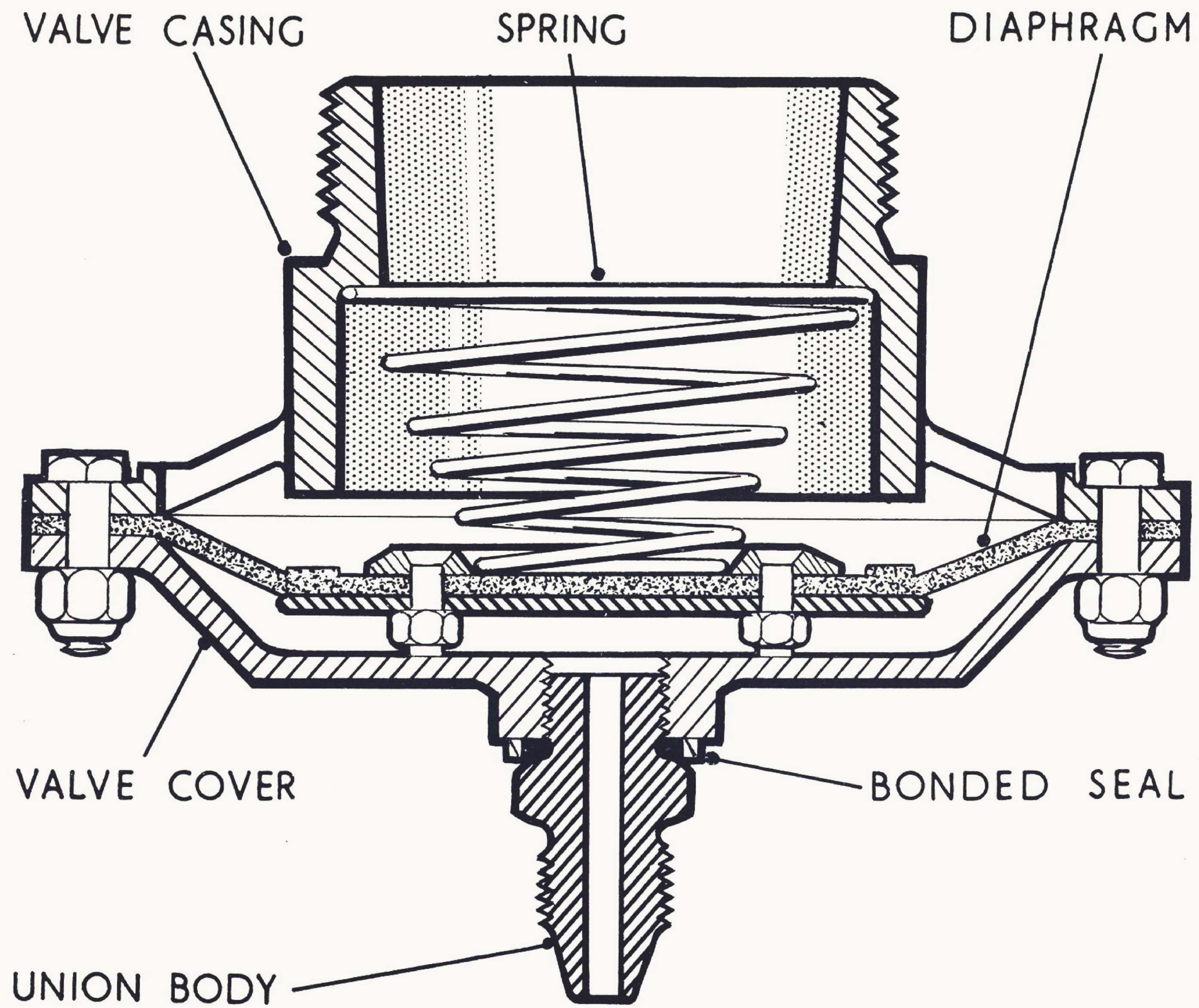

FIG.1 AIR EXTRACTION VALVE

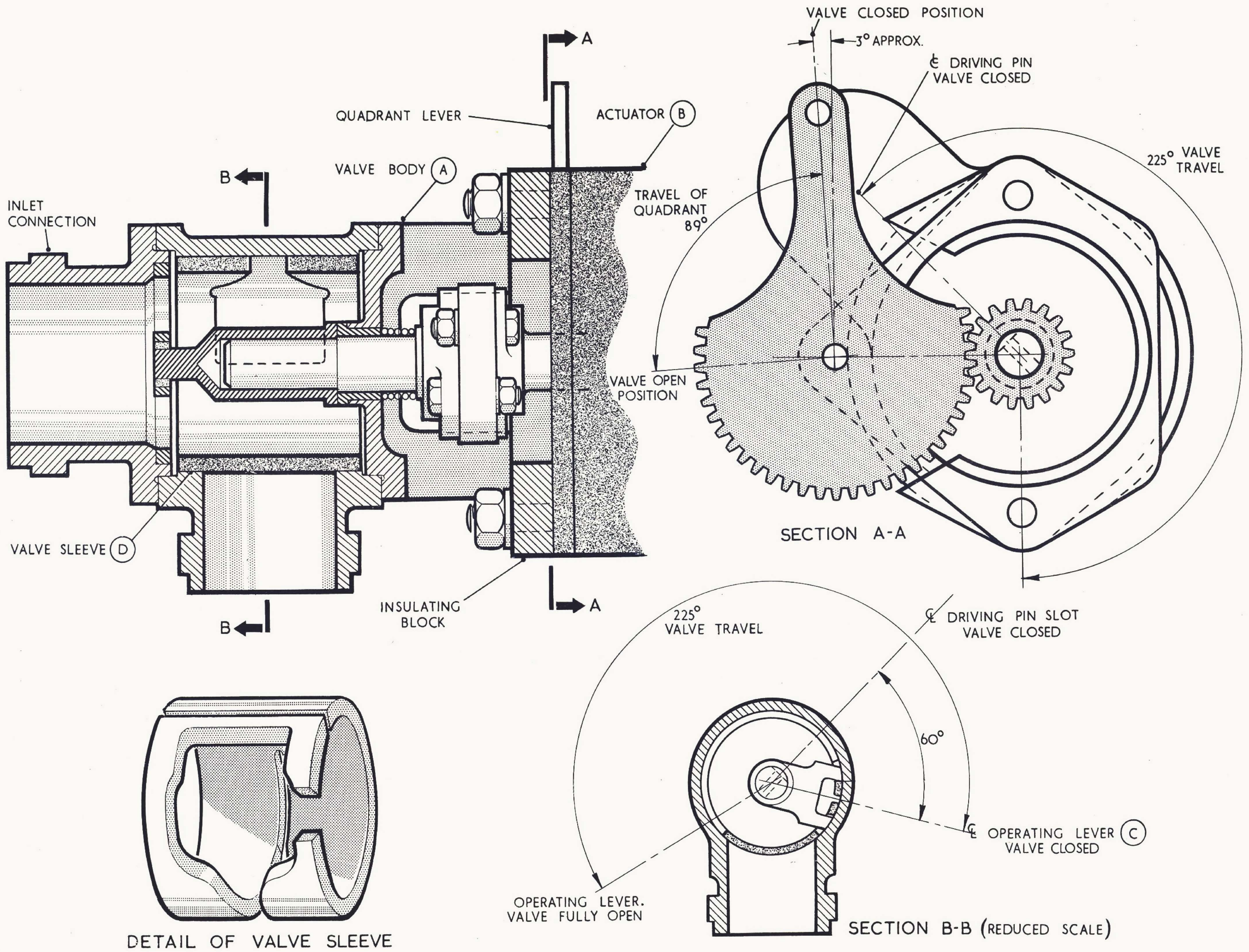

FIG. 2 TEMPERATURE CONTROL VALVE

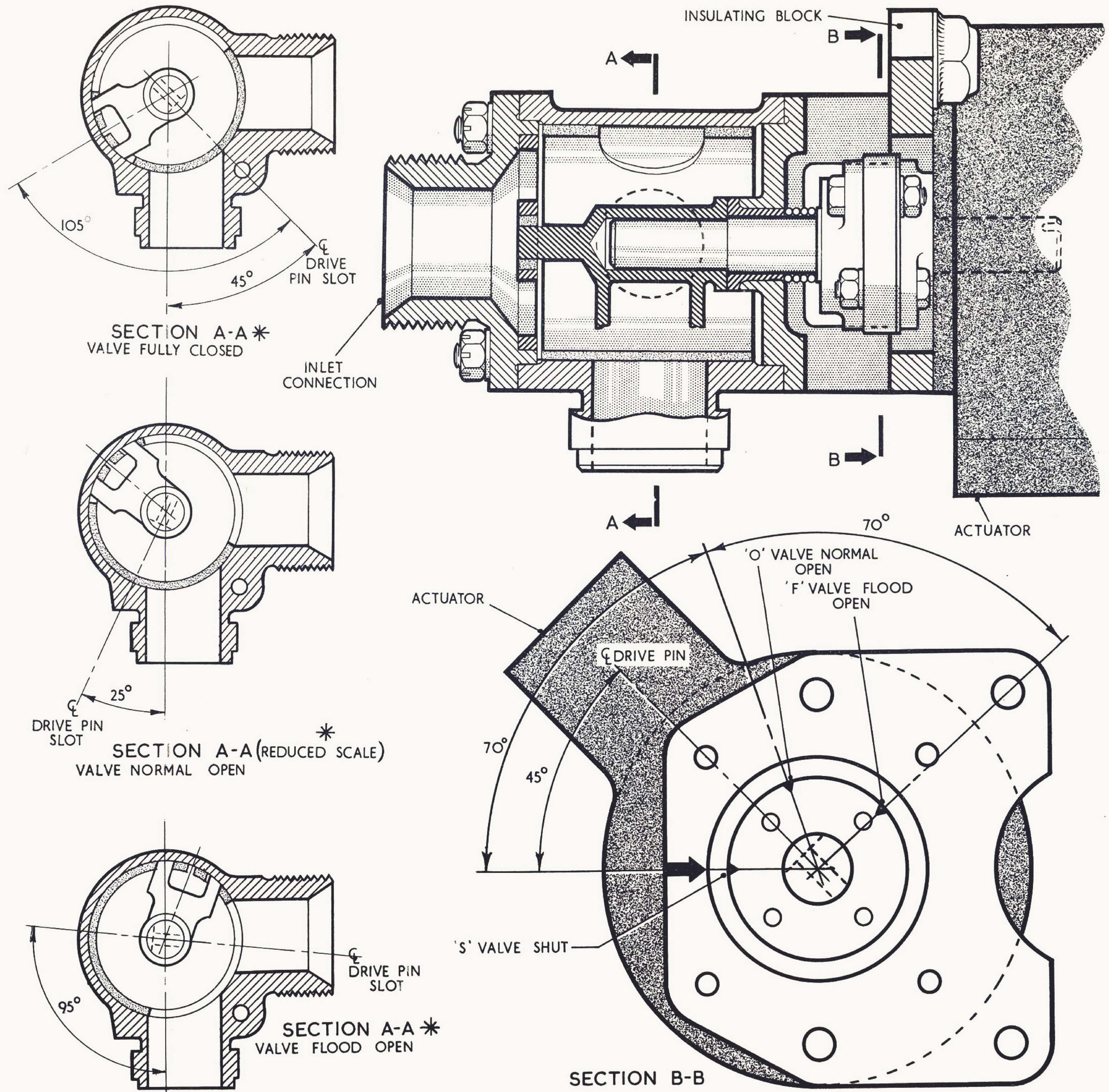

FIG.3 AIR SUPPLY VALVE

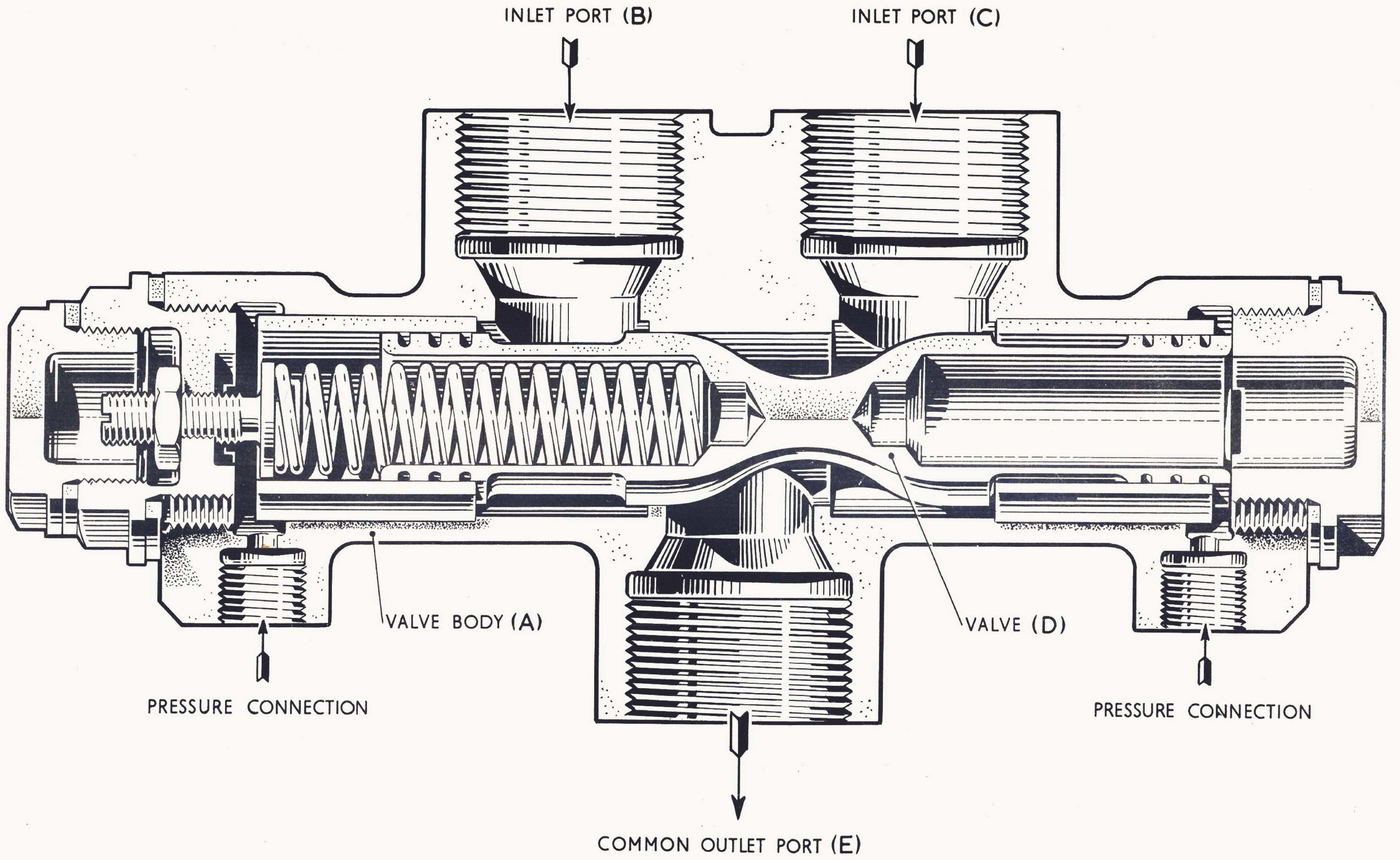

FIG. 4 PRE-COOLER BY-PASS VALVE

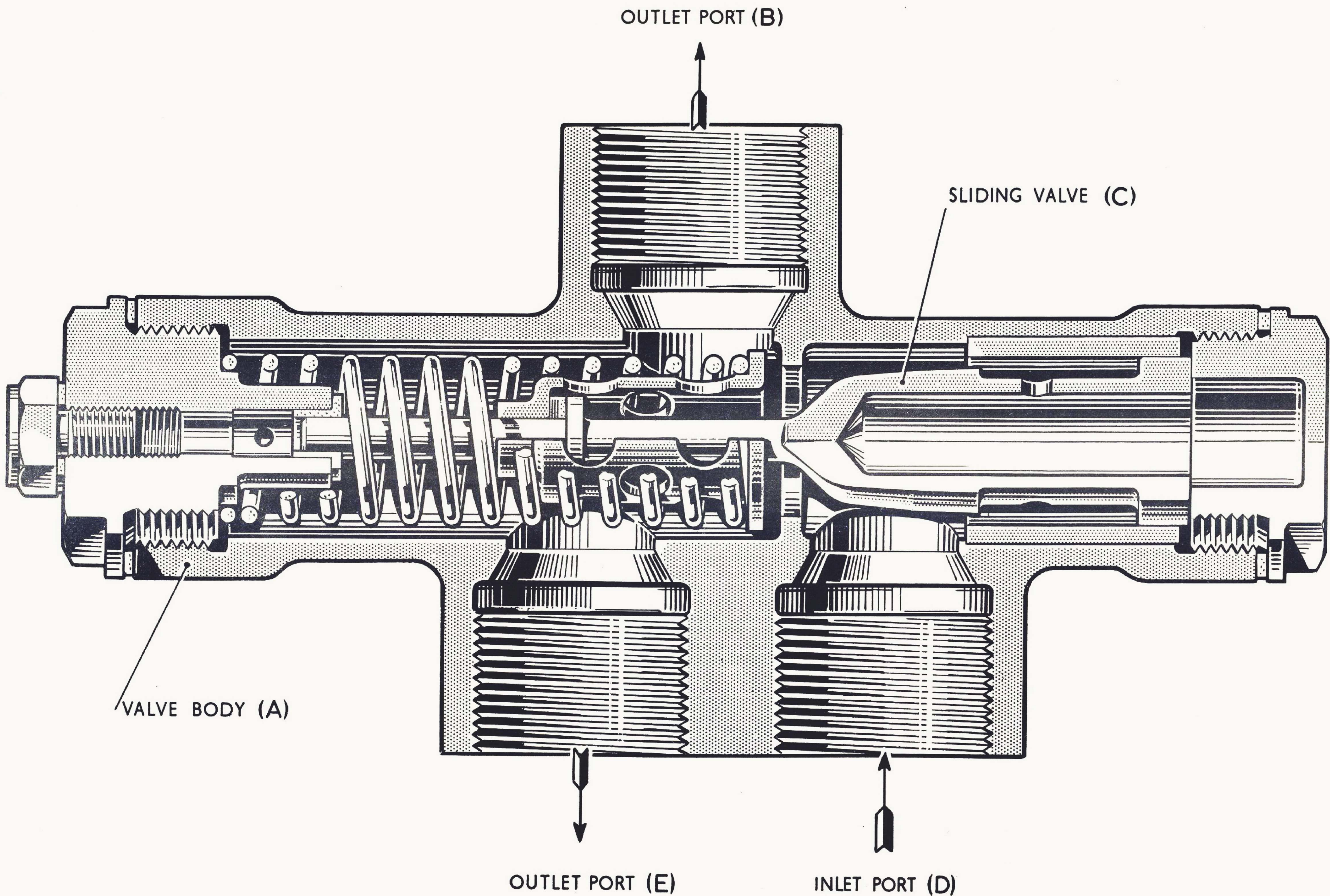

FIG. 5 VARIABLE ORIFICE VALVE

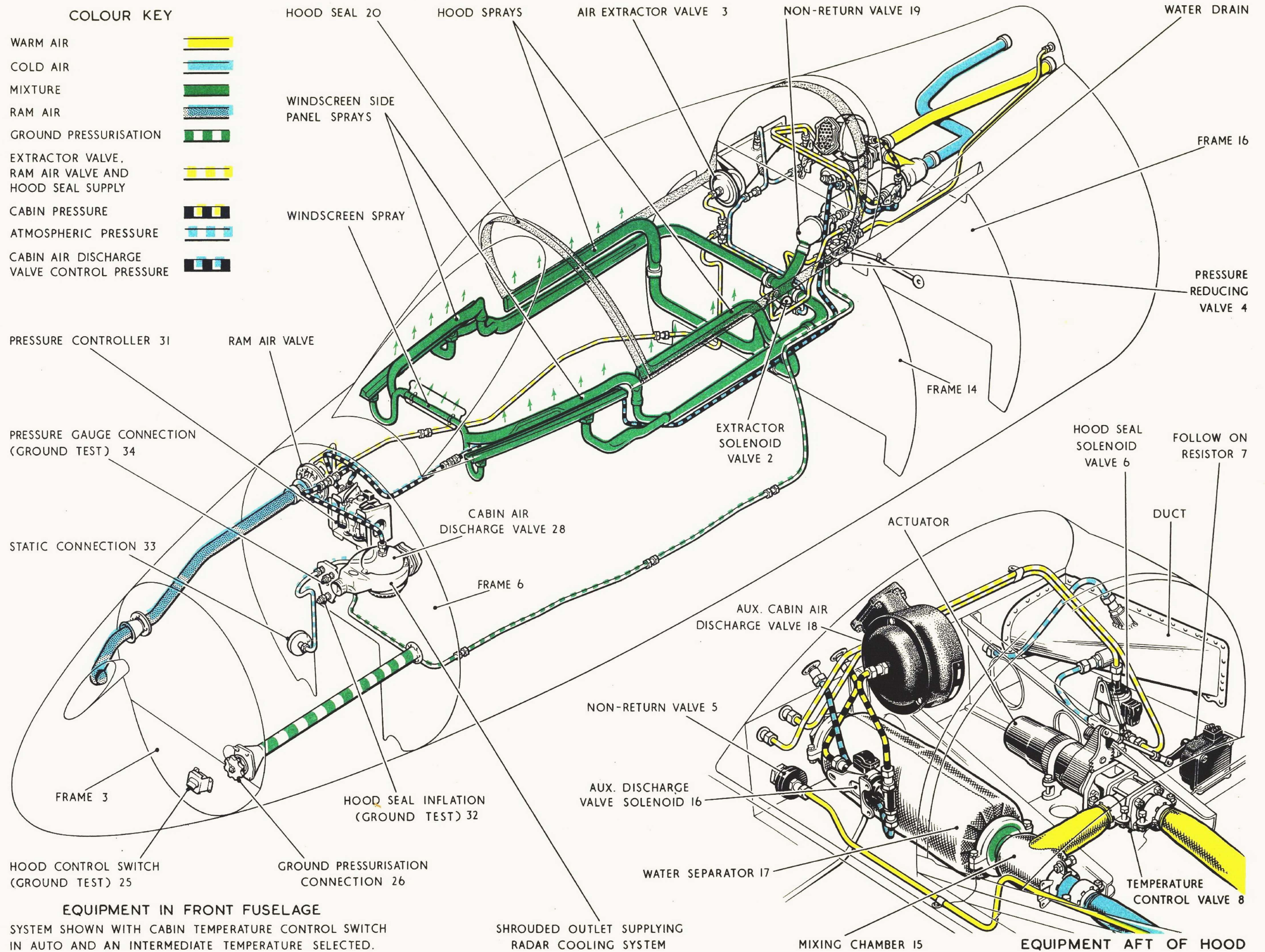
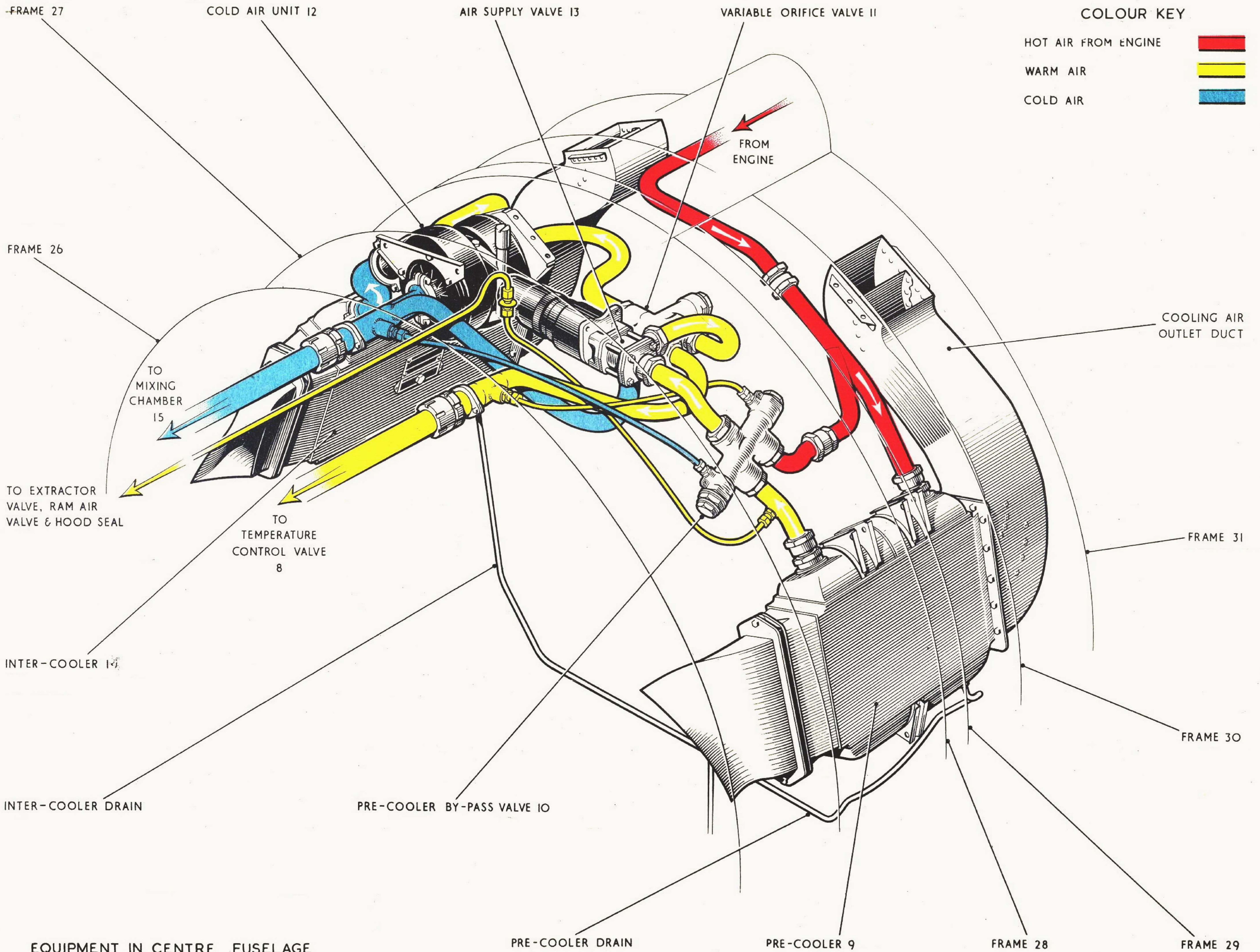
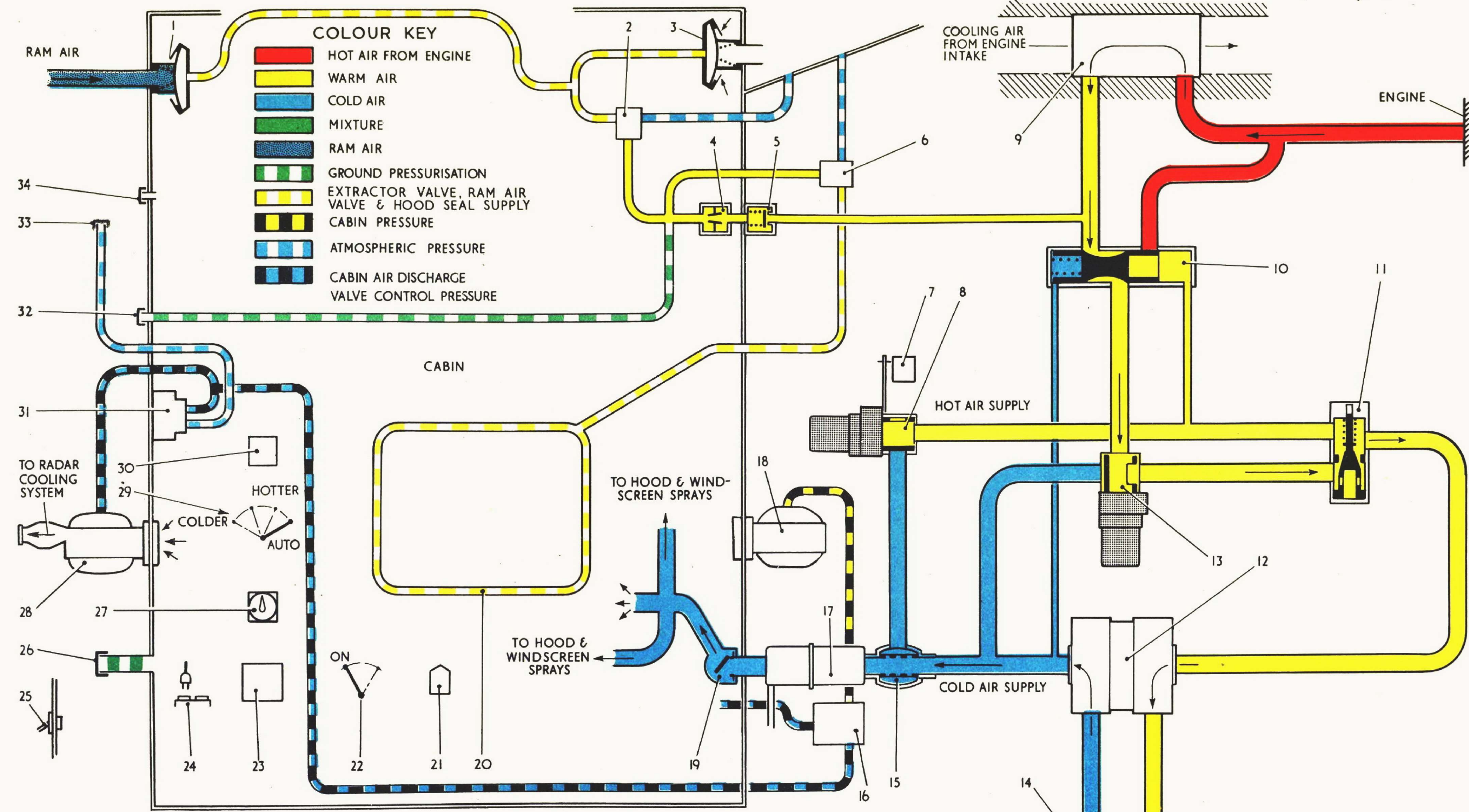

FIG. 6 AIR CONDITIONING SYSTEM INSTALLATION (I)



EQUIPMENT IN CENTRE FUSELAGE  
 SYSTEM SHOWN WITH CABIN TEMPERATURE CONTROL SWITCH  
 IN AUTO AND AN INTERMEDIATE TEMPERATURE SELECTED.

FIG. 7 AIR CONDITIONING SYSTEM INSTALLATION (2)



- |  |  |
|--|--|
| <ul style="list-style-type: none"> <li>1 RAM AIR VALVE</li> <li>2 EXTRACTOR SOLENOID VALVE</li> <li>3 AIR EXTRACTOR VALVE</li> <li>4 PRESSURE REDUCING VALVE</li> <li>5 NON-RETURN VALVE</li> <li>6 HOOD SEAL SOLENOID VALVE</li> <li>7 FOLLOW-ON RESISTOR</li> <li>8 TEMPERATURE CONTROL VALVE</li> <li>9 PRE-COOLER</li> <li>10 PRE-COOLER BY-PASS VALVE</li> <li>11 VARIABLE ORIFICE VALVE</li> <li>12 COLD AIR UNIT</li> <li>13 AIR SUPPLY VALVE</li> <li>14 INTER-COOLER</li> <li>15 MIXING CHAMBER</li> <li>16 AUX DISCHARGE VALVE SOLENOID</li> <li>17 WATER SEPARATOR</li> </ul> | <ul style="list-style-type: none"> <li>18 AUX CABIN AIR DISCHARGE VALVE</li> <li>19 NON-RETURN VALVE</li> <li>20 HOOD SEAL</li> <li>21 ALTITUDE SWITCH (FLOOD CONTROL)</li> <li>22 CABIN PRESSURE CONTROL SWITCH</li> <li>23 AMPLIFIER</li> <li>24 PLUG AND SOCKET (HOOD CONTROL)</li> <li>25 SWITCH (HOOD CONTROL)</li> <li>26 GROUND PRESSURISATION CONNECTION</li> <li>27 TEMPERATURE SELECTOR</li> <li>28 CABIN AIR DISCHARGE VALVE</li> <li>29 CABIN TEMPERATURE CONTROL SWITCH</li> <li>30 CABIN ELEMENT</li> <li>31 PRESSURE CONTROLLER</li> <li>32 HOOD SEAL INFLATION (EXTERNAL SUPPLY)</li> <li>33 STATIC CONNECTION</li> <li>34 PRESSURE GAUGE CONNECTION (EXTERNAL)</li> </ul> |
|--|--|

**DIAGRAM FOR 'FULLY COLD' DELIVERY (ALL AIR THROUGH COLD AIR UNIT)**  
 CABIN TEMPERATURE CONTROL SWITCH 29 IN AUTO, & TEMPERATURE SELECTOR 27  
 SET TO PROVIDE LOW TEMPERATURE AIR  
 ALTERNATIVELY FOR MANUAL SETTING 'COLDER' ON SWITCH 29

**FIG. 8 AIR CONDITIONING SYSTEM DIAGRAM (I)**

**RESTRICTED**

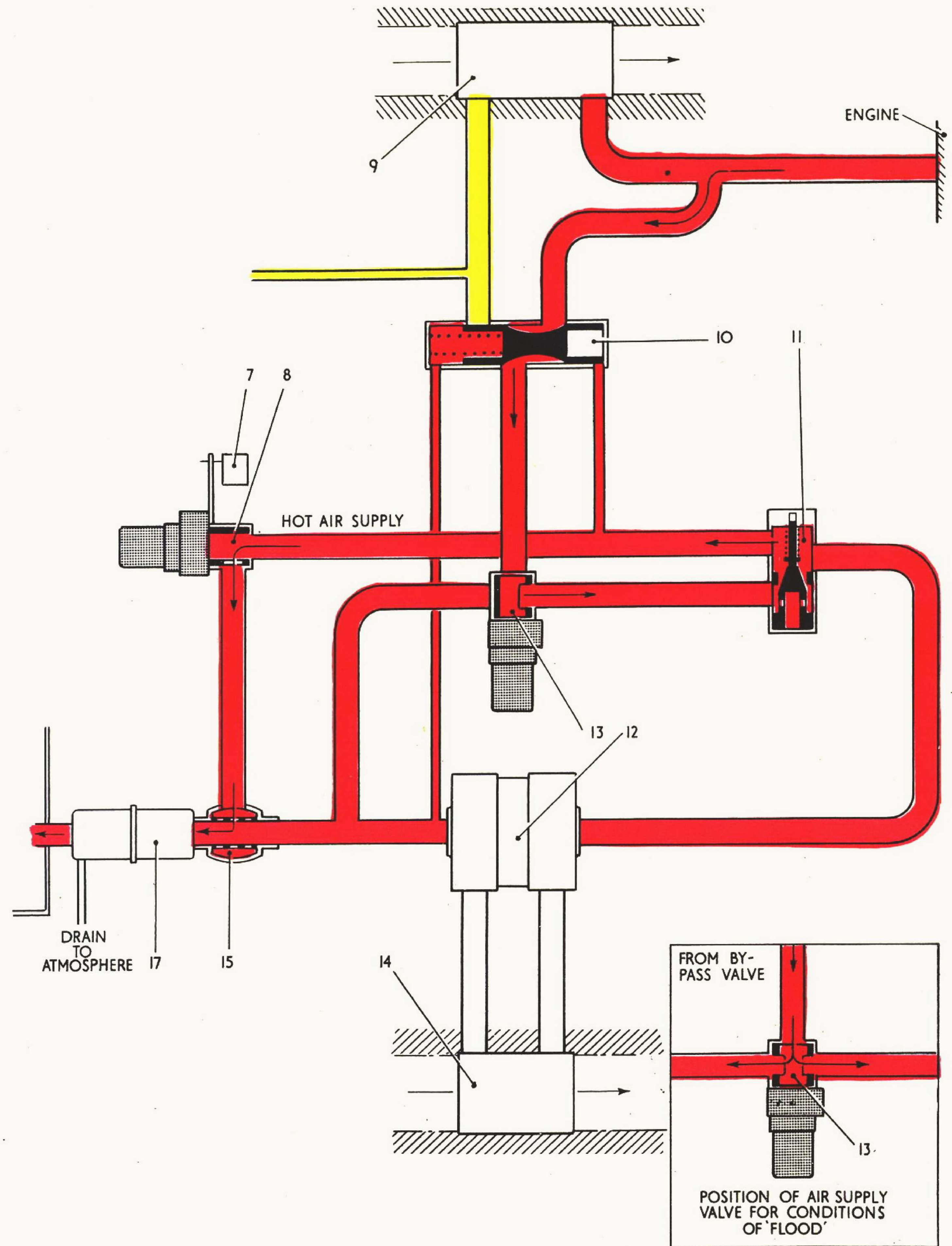
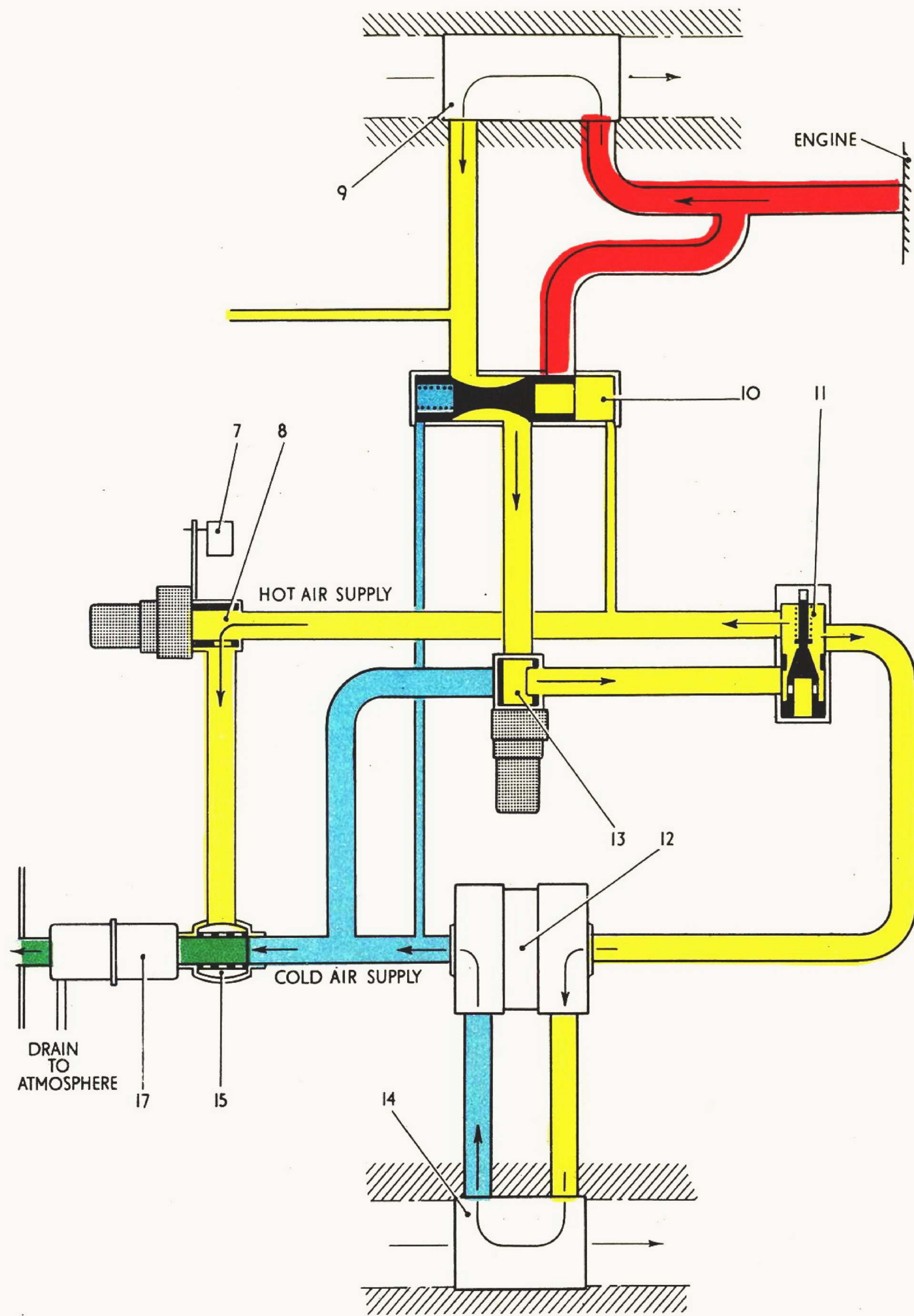

DIAGRAM FOR INTERMEDIATE TEMPERATURES (MIXTURE OF HOT & COLD AIR)  
 CABIN TEMPERATURE CONTROL SWITCH 29 IN AUTO. & TEMPERATURE SELECTOR 27 SET  
 TO PROVIDE REQUIRED TEMPERATURE OF AIR

DIAGRAM FOR 'FULLY HOT' DELIVERY (COLD AIR UNIT BY-PASSED)  
 CABIN TEMPERATURE CONTROL SWITCH 29 IN AUTO. & TEMPERATURE  
 SELECTOR 27 SET TO PROVIDE HIGH TEMPERATURE AIR  
 ALTERNATIVELY FOR MANUAL SETTING 'HOTTER' ON SWITCH 29

FIG. 9 AIR CONDITIONING SYSTEM DIAGRAM (2)

RESTRICTED

This file was downloaded  
from the RTFM Library.  
Link: [www.scottbouch.com/rtfm](http://www.scottbouch.com/rtfm)  
Please see site for usage terms,  
and more aircraft documents.

