

GROUP D.10

AIR BRAKE CONTROL (CODE AB)

LIST OF CONTENTS

	<u>Para.</u>		<u>Para.</u>
Equipment employed ... ..	1	<b>SERVICING</b>	
DESCRIPTION		General ... ..	7
Air brake control ... ..	2	<b>REMOVAL AND ASSEMBLY</b>	
Operation ... ..	3	General ... ..	8

ILLUSTRATION

	<u>Fig.</u>
Air brake control ... ..	1

Equipment employed

1. The major components employed in the air brake control circuit are quoted below, together with the appropriate Air Publications to which reference

should be made for a detailed description and the necessary servicing required to maintain them in an efficient condition.

Solenoid valve Type C.5701Y, Mk.B ... ..	A.P.1803D, Vol.1, Book 3, Sect.8, Chap.23
Solenoid valve Type C.5705, Mk.A ... ..	A.P.1803D, Vol.1, Book 3, Sect.8, Chap.20
Pressure switch Type TP.5300, 5300/1, 5300/2 or 1300 ... ..	A.P.1275A, Vol.1, Sect.11, Chap. -
Magnetic indicator Dowty Type C.5165Y or Type A.2 ... ..	A.P.4343E, Vol.1, Sect.18, Chap. -
Micro switches Type 1A .. ...	A.P.4343B, Vol.1, Sect.20, Chap.4
Relays, Type 9B, No.1 ... ..	A.P.4343C, Vol.1, Sect.3, Chap. -
Relay, Type S, No.1 . ... ..	A.P.4343C, Vol.1, Sect.3, Chap.8.

## DESCRIPTION

### Air Brake control

2. The electrical control circuit for the hydraulically operated air brake is actuated by a thumb switch incorporated in the throttle twist grip. This switch controls two electro-hydraulic solenoid valves located in the rear fuselage on the port side adjacent to frame 50, via a relay box and a hydraulic pressure switch. The relay box, which contains three control relays and a spring return test switch, is located in the cabin just aft of the hood control switch box, while the hydraulic pressure switch is mounted adjacent to the solenoid valves in the rear fuselage. To indicate the position of the air brake, a magnetic indicator is installed on the port instrument panel adjacent to the undercarriage warning lamp. This instrument gives a white indication when the air brake is extended and black when retracted, it is controlled by a micro switch situated on a bracket attached to frame 47. To prevent damage due to the limited ground clearance, the airbrake control circuit is interconnected with the UP button of the alighting gear selector switch in such a manner that it is impossible to extend the air brake by the normal control, while the alighting gear is lowered. If the alighting gear is lowered while the air brake is extended, the air brake will automatically retract due to this interconnection. The same action will also be obtained by the closing of a micro-switch, located below the cabin port shelf, which is operated by the alighting gear emergency air valve when the alighting gear emergency lowering system is employed. The installation may, however, be tested on the ground while the alighting gear is down, by operation of the spring return test switch on the relay box. Operation of this switch, in conjunction with a micro switch, located adjacent to the airbrake port hinge, will permit partial extension and immediate retraction of the air brake to give indication on the magnetic indicator in the cabin, that the system is operating satisfactorily.

## Operation

3. When the alighting gear is retracted, contacts 3 and 4 of the alighting gear control UP switch (Group D7) are made and supply the air brake control switch via the normally closed contacts of the alighting gear emergency air valve micro switch. Operation of the air brake switch to the OUT position will now energize the solenoid of the main electro-hydraulic valve and hold-on relay P.1. A supply is also made to the hydraulic pressure switch, the contacts of which are open at this time. After the control switch is released, the circuit to the solenoid valve is maintained via the closed contacts 3, 4, 5 and 6 of relay P.1, contacts 5 and 6 of the test switch and contacts 2 and 4 of the de-energized relay R.1. The air brake jack will now extend to put the air brake out, by differential action at high speed, until the rise in hydraulic pressure due to the air load on the air brake causes the hydraulic pressure switch to operate and close its contacts. The closing of these contacts completes the supply to the solenoid of the high speed electro-hydraulic control valve, the circuit being maintained once the pressure switch is operated via contacts 3, 4, 5 and 6 of the hold-on relay N.1 which is also energized by the pressure switch. The jack continues to extend to put the air brake out, but now at full power normal speed, until the full out position is reached. When the air brake starts to extend, the aft micro switch completes the earth return for the magnetic indicator which is energized by a supply from the circuit fuse and shows white to indicate that the air brake is extended.

4. If the alighting gear is selected down, while the air brake is extended, the UP switch of the alighting gear control will immediately break contacts 3 and 4 to disconnect the supply to the air brake control switch, de-energize the electro-hydraulic control valves and hold-on relays, thus automatically retracting the air brake. The same

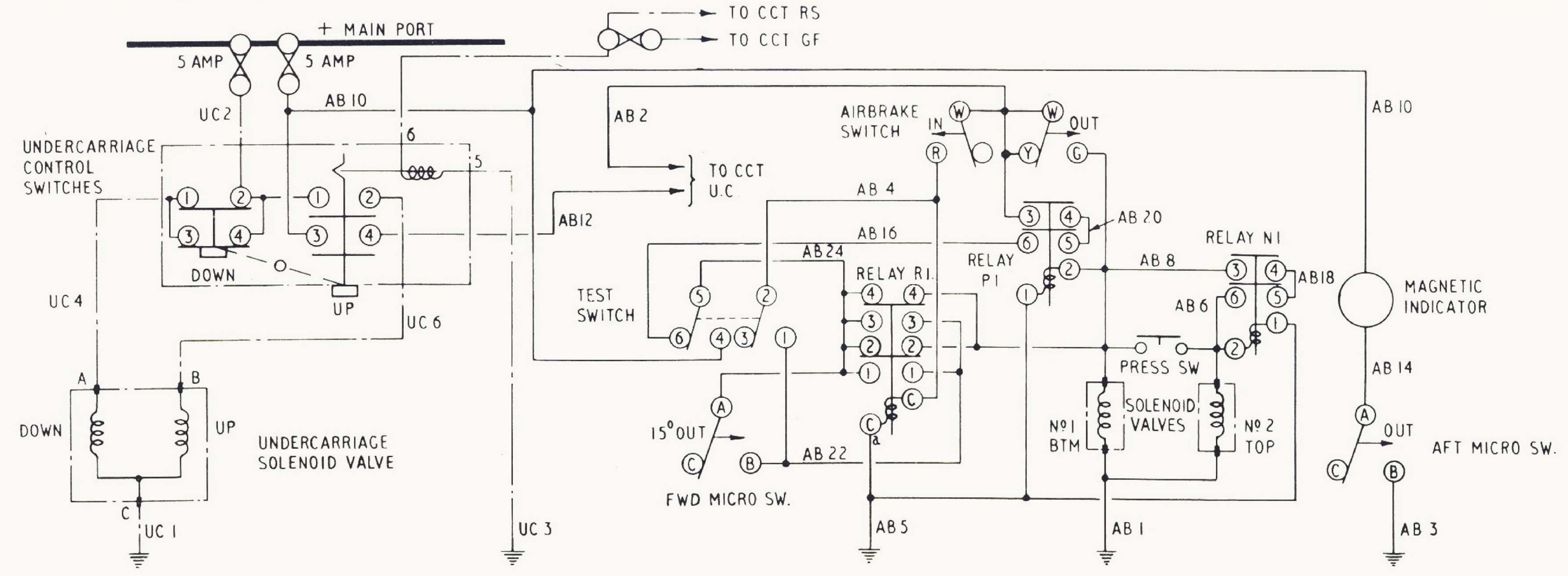
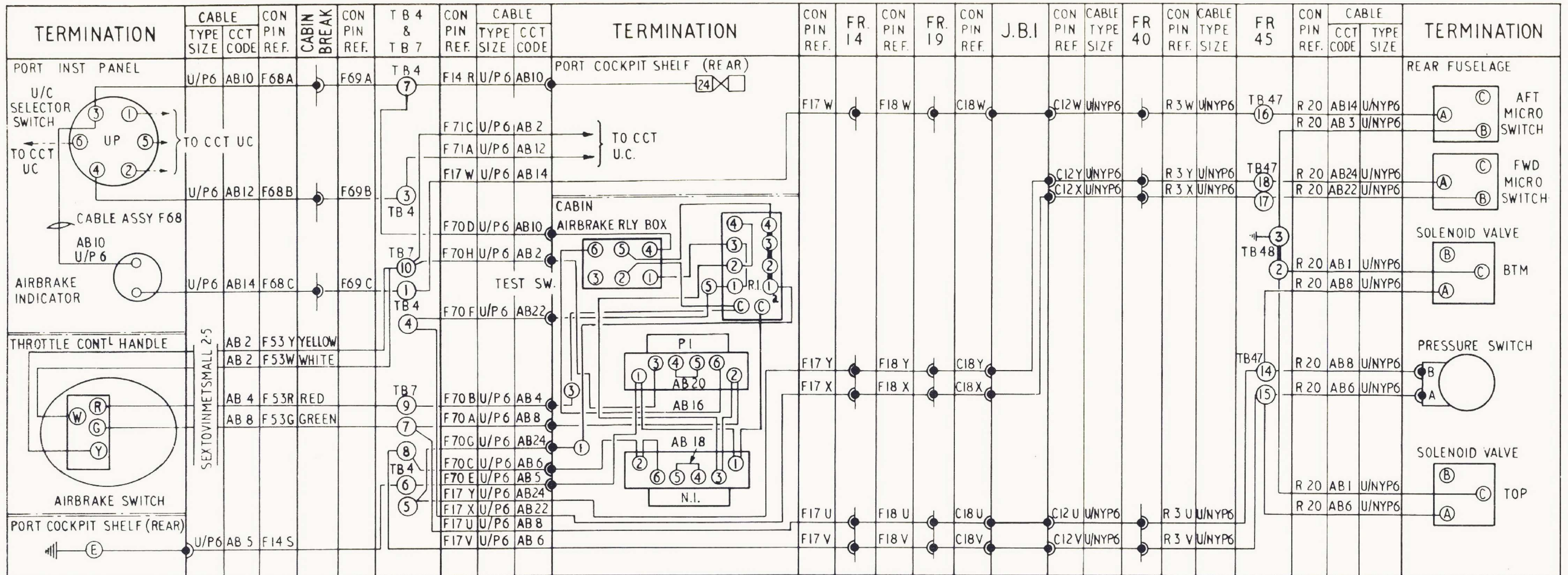

FIG. 1 AIR BRAKE CONTROL

**RESTRICTED**

action is also obtained on the use of the alighting gear emergency lowering system by the opening of the contacts of the micro switch operated by the emergency air valve. Air brake retraction must not normally be obtained by selecting alighting gear down.

5. On operation of the air brake control switch to the IN position, relay R.1 is energized to break the circuit to the hold-on relays P.1 and N.1 thus de-energizing the solenoids of the electro-hydraulic control valves. With the control valves de-energized the air brake jack will retract and bring the air brake to the IN position. When the air brake is fully IN, the aft micro switch contacts are broken thus de-energizing the magnetic indicator which will show black to indicate that the air brake is retracted.

6. The operation of the spring return test switch used to test the installation on the ground while the alighting gear is down, is such that when it is placed in the ON position, current is conducted from the circuit fuse, through contacts 4 and 5 of the test switch and contacts 2 and 4 of relay R1 to energize the solenoid of the main electro-hydraulic control valve. The air brake jack will now extend to put the air brake out, until at a position of approximately 15 deg. out, the forward micro switch is operated by the air brake hinge arm. When operated this micro switch completes the supply via contacts A and B to the coil of relay R1, via contacts 1 and 2 in the test switch. When energized this relay breaks the supply to the electro-hydraulic control valve and the air brake immediately retracts. Relay R1 is maintained in the energized state by a hold-on circuit through its own contacts until the test switch is released and returns to the OFF position. As the air brake extends the magnetic indicator is energized by the operation of the aft micro switch in a similar manner to that described in para.3 to provide indication that the installation is operating satisfactorily.

## SERVICING

### General

7. For general servicing of the electrical system as a whole, reference should be made to Group A of this chapter. Apart from keeping all the components clean and carrying out the normal routine tests of security and serviceability the only other servicing necessary is the adjustment of the micro switches to ensure the correct functioning of the installation and magnetic indicator as described in Sect.3, Chap.4 followed by the functioning checks of the installation as described in Sect.3, Chap.6 of this volume. The electrical tests of the electro-hydraulic control valves are described in the appropriate Air Publication quoted in para.1 of this group.

## REMOVAL AND ASSEMBLY

### General

8. Once access has been obtained, the removal and assembly of the components forming the air brake control circuit should present no unusual difficulties. The location and access to all the components is indicated in Group A of this chapter.

This file was downloaded  
from the RTFM Library.

Link: [www.scottbouch.com/rtfm](http://www.scottbouch.com/rtfm)

Please see site for usage terms,  
and more aircraft documents.

