

GROUP G.1.

ARMAMENT SUPPLIES AND CONTROL

(Code GF, GV, GH, BR, BF, BJ, RP, JG and CG)

LIST OF CONTENTS

	<u>Para.</u>		<u>Para.</u>
Equipment employed	1	REMOVAL AND ASSEMBLY	
DESCRIPTION		General	30
Gun firing, ventilation and heating... ..	2	LIST OF ILLUSTRATIONS	
Operation	6	Gun firing, ventilation, heating and camera (routing)	<u>Fig.</u> 1
Bomb release, fuzeing and jettison	9	Gun firing, ventilation, heating and camera (theoretical)	2
Operation	10	Bombs and R.P.(routing - front fuselage)..	3
R.P.firing... ..	16	Bombs and R.P.(routing - centre fuselage).	4
Operation	17	Bombs and R.P.(routing - wings)	5
Pylon stores jettison	23	Inboard and outboard pylon stores(routing)..	6
Operation	24	Bombs and pylon stores(theoretical)	7
G.45B camera	25	R.P.(theoretical)... ..	8
Operation	26		
SERVICING			
General	29		

Equipment employed

1. The major components employed in the armament supplies and control circuits are quoted below, together with the appropriate Air Publications to

which reference should be made for a detailed description and the necessary servicing required to maintain them in an efficient condition :-

Control column handgrip, Type A.C.10922	A.P.4343X, Vol.1, Sect.7, Chap.-.
Butt test, camera master and sunny/cloudy switches, Rotax Type D.5404	A.P.4343C, Vol.1, Sect.1, Chap.28.
Compression Switches, Dowty Type C.1831Y, Mk.2.	A.P.4343C, Vol.1, Sect.1, Chap.25.
Gun firing inverter, Type 300	A.P.4343B, Vol.1, Sect.16, Chap.11.
Hot air valve actuator, Type CZ.72256	A.P.4343D, Vol.1, Sect.14, Chap.-.
Gun ventilation actuator, Type CZ.72257... ..	A.P.4343D, Vol.1, Sect.14, Chap.32.
Camera gun, Type G.45B, Mk.3	A.P.1355D, Vol.1, Sect.1, Chap.-.
Camera recorder, Mk.3.	A.P.1355D, Vol.1, Sect.3, Chap.2.
Gun firing fuses, 2 Amp. Ref.10/2590110... ..	A.P. , Vol.1, Sect. Chap.-.
Circuit breaker, Type A.1.	A.P.4343B, Vol.1, Sect.10, Chap.6.
Relays, Type S, No.3	A.P.4343C, Vol.1, Sect.3, Chap.8.
Relays, Type 9B, No.1	A.P.4343C, Vol.1, Sect.3, Chap.-.

Thermostat, Type F.H.O./A/96	...	A.P.	, Vol.1, Sect.	, Chap.-.
Bomb/R.P.switch, Rotax, Type D.5501.	...	A.P.4343C,	Vol.1, Sect.1,	Chap.28.
Ripple/normal and practice/normal switches, Rotax, Type D.5406.	...	A.P.4343C,	Vol.1, Sect.1,	Chap.28.
R.P.selector switch	...	A.P.4343X,	Vol.1, Sect.16,	Chap.3.
Re-set, outer stores jettison and clear aircraft push-switches, Type B.	...	A.P.4343C,	Vol.1, Sect.1,	Chap.3.
Re-set indicator, Type A.2.	...	A.P.4343E,	Vol.1, Sect.18,	Chap.-.
R.P.firing distribution box, Type 2.	...	A.P.4343X,	Vol.1, Sect.16,	Chap.2.
Rippling relay, Type S.M.5-H.12	...	A.P.4343C,	Vol.1, Sect.3,	Chap.-.
Fuzing selector rotary switch, Type B.	...	A.P.4343C,	Vol.1, Sect.1,	Chap.2.
Slip release units, No.1, Mk.1.	...	A.P.4343X,	Vol.1, Sect.5,	Chap.-.
Nose and tail fuzing units, No.3, Mk.1..or Ferranti	...	A.P.4343X,	Vol.1, Sect.5,	Chap.-.
Series relay, Type B	...	A.P.4343C,	Vol.1, Sect.3,	Chap.-.

DESCRIPTION

Gun firing, ventilation and heating

2. The 30 mm. Aden guns are controlled and fired electrically, via a junction box on each gun, the firing operation being actuated by a trigger-operated switch located on the forward face of the control column handgrip. This handgrip also contains two push-switches and the tail plane switch. Both push-switches are located at the top of the handgrip, under two spring-loaded flaps. One switch is used to operate the camera gun independently of the guns, while the other is used for bomb release or R.P. firing. The flap over the camera gun switch forms the gun safety catch and must be lifted before the guns can be fired. It is, however, cut-away locally to enable the camera gun switch to be pressed as desired, without lifting the flap.

3. The supply to the camera, safety and gun firing switches is taken through an easily accessible safety plug located in the port stub wing and through two alighting gear compression switches located one on each main undercarriage leg. When disconnected, the safety plug renders all the armament services inoperative. The compression switches are provided to prevent the guns or R.P.being fired, the camera

operated or the bombs released while the aircraft is on the ground. The compression switches may, however, be overridden by use of a butt switch located on the cabin starboard shelf when it is required to fire the guns at the butts. The supply from the safety flap and firing trigger switches energizes the safety and gun firing relays controlling the input and output of an inverter, which is protected by a circuit breaker and used to energize the guns. The firing relay is also linked with the gun ventilation circuit (para.4.). The inverter, circuit breaker and relays are all mounted on the gun firing panel located in the radio bay.

4. Whenever the guns are fired, the gun bay is automatically ventilated by the opening of a small shutter incorporated in the gun bay access door. This shutter is opened and closed by an actuator also mounted on the access door. The actuator is controlled by a relay mounted on the gun firing panel located in the radio bay and the circuit is linked with the firing relay in the gun firing circuit. The ventilation shutter must fully open in 3.5 seconds at the commencement of the guns firing and close in 3.5 seconds at the end of the

guns firing.

5. The guns are heated by hot air taken from the engine compressor. The supply of air to the gun package is controlled by a hot air valve, which is operated by an actuator controlled by a thermostat. The hot air valve actuator is mounted on the forward face of frame 19 in the radio bay, while the thermostat is located in the gun package.

Operation.

6. As the aircraft becomes airborne, the weight is taken off its alighting gear, thus allowing the compression switches on each main undercarriage leg to make contact and with the safety plug connected feed the positive supply to the switches in the control column handgrip. When it is required to fire the guns, it is first necessary to raise the safety flap as this action closes a switch, which completes the circuit to the firing trigger switch and also energizes the safety relay. The safety relay controls the input to and output from the gun firing inverter and, when energized, allows the main positive supply from the circuit breaker to energize the inverter, via one set of contacts. The output from the inverter is conducted to the firing relay via the other set of contacts. As the firing trigger is pressed, it closes the firing switch to energize the firing relay, the contacts of which complete the supply from the inverter to the guns and the guns fire. At the same time, the gun ventilation shutter commences to open, as described in para.7. and the camera gun operates to photograph the target, as described in para.27.

7. When the guns are fired, as described in para.6 the firing relay in the gun firing circuit is energized, breaking contacts 6-6a of the relay supplying contacts 6-6a of the gun ventilation relay, which feeds the 'close' field coil of the ventilation shutter actuator and makes contacts 5-5a to complete the circuit to the actuator 'open' field coil.

The actuator will therefore commence operation to open the shutter. At the same time contacts 5-5a and 7-7a in the firing relay complete the supply to energize the gun ventilation relay, via the 'open' limit switch of the actuator. Should the firing switch be released and the firing relay de-energized before the actuator completes its full travel, the gun ventilation relay will be maintained in the energized state, by a hold-up circuit through its contacts 3-3a, the actuator 'open' limit switch and contacts 1-1a. This feed also supplies the 'open' field coil of the actuator direct from the circuit fuse via contacts 3-3a. When the actuator completes its full travel, the 'open' limit will be broken, thus stopping the actuator and de-energizing the gun ventilation relay. If, however, the firing relay is still energized, the actuator will remain stationary, thus keeping the shutter open. When the guns stop firing, the firing relay is de-energized and the circuit to the 'close' field coil of the actuator will be completed via contacts 6-6a of the gun firing and ventilation relays. The actuator will now run to close the shutter, until switched off by the 'close' limit switch.

8. The operation of the gun heating circuit is such that when the temperature in the gun package is below approximately 10 deg.C. the thermostat makes contacts 1 and 2 to complete the supply to the 'open' field coil of the hot air valve actuator, which thus commences operation and opens the valve to allow hot air from the engine compressor to enter the gun package. When the temperature in the package reaches approximately 30 deg.C., contacts 1 and 2 of the thermostat open and contacts 1 and 3 make, to supply the 'shut' field coil of the valve actuator. The actuator then closes the valve, thus cutting off the hot air supply to the gun package. The temperature in the gun package is, therefore, automatically maintained between the two limits set by the thermostat.

RESTRICTED

Bomb release, fuzing and jettison.

9. The bombs are released from the inboard pylons by depression of the bomb/R.P. push switch, located at the top of the control handgrip, after they have been selected and fuzed by operation of the BOMB/R.P. selector switch and FUZING selector switch situated on the bomb/R.P. control panel in the cabin. If necessary, the bombs may be jettisoned in a safe condition, i.e. not fuzed, by depression of a CLEAR AIRCRAFT push switch situated on the R.P. selector panel. The supply to the bomb/R.P. push switch is taken through the safety plug and alighting gear compression switches in a similar manner to that for the gun firing trigger switch, as described in para.3, while the supply to the BOMB/R.P. selector, FUZING selector and CLEAR AIRCRAFT switches is taken via the safety plug from a 10 amp. circuit breaker situated on the supply panel. The electro-magnetic bomb release slips, jettison solenoids and fuzing units, which are all located in the inboard pylons, are actuated by a bomb/R.P. firing relay, fuzing relay and pylon stores jettison relay situated on the leg panel and in ARM J.B.2. The operation of these relays and the cock test, practice bomb and variable time fuze sockets, together with the NORMAL/PRACTICE change over switch and series relay, which are all located in the pylons, is described in the following paragraphs.

Operation

10. When the aircraft is airborne, the bomb/R.P. release push-switch on the control column handgrip is supplied, via the safety plug and compression switches, as described in para.6, in preparation for energizing the bomb/R.P.firing relay when the push-switch is depressed. The FUZING selector and BOMB/R.P. switches are also supplied via the safety plug. With the FUZING selector in the OFF position a supply is made to the CLEAR AIRCRAFT push switch in preparation for energizing the pylon stores jettison relay when this latter switch is depressed. When the FUZING selector is placed in the TAIL position

a supply is made to the tail fuzing units in the pylons, via a set of contacts in the pylon stores jettison relay which are made while the relay is de-energized. In the TAIL and NOSE position, the fuzing relay is energized and a supply made, via the contacts of the de-energized pylon stores jettison relay, to the tail and nose fuzing units in each pylon.

11. With the BOMB/R.P. switch set to the BOMBS position, a supply is made to three contacts in the bomb/R.P.firing relay in preparation for supplying the bomb release gear when the relay is energized by the depression of the bomb release push switch. With the firing relay energized, contacts 3-3a and 1-1a will feed the port and starboard release slip solenoids respectively, via the operating coils of the series relays and the release slip isolation switches in each pylon. The release slips will open to drop both bombs and the series relays will also operate and be maintained in this state by hold-on coils fed through their own contacts. Further contacts in the series relays will supply the variable time fuze sockets to energize these fuzes as the bombs fall. The remaining set of contacts (i.e.5-5a) in the firing relay will supply each jettison solenoid, via the NORMAL/PRACTICE switches, when in the NORMAL position. The jettison solenoids operate the mechanical release plungers on each release slip, thus opening the release hooks mechanically if they have not already opened electrically.

12. Depression of the CLEAR AIRCRAFT push switch, while the FUZING selector is in the OFF position, will energize the pylon stores jettison relay and the jettison solenoids in each pylon. With the jettison relay energized a supply is made to the normal release slip solenoids, via the series relays and release slip isolation switches. The series relays, jettison solenoids and release slips will all operate as described in para.11, but the nose, tail and variable time fuse units will not be energized as

the fuizing supplies are isolated at the FUZING selector and jettison relay, thus the bombs will fall in a safe unfuzed condition.

13. The cock test sockets are used to connect a test set, consisting of a lamp and battery, to the release slip circuit. The lamp will light when the release slip is correctly cocked, as a circuit is made through the release slip feed switches, solenoid coil and the test set.

14. When practice bomb carriers are installed on the pylons, the pylon release slip isolation switches are automatically broken to isolate the normal release mechanisms and the practice carrier release gear is fed from the practice bomb sockets. The NORMAL/PRACTICE switches in each pylon must also be placed in the PRACTICE position to change over the supply to the jettison solenoids, thus preventing them from being energized and jettisoning the carriers when the practice bombs are dropped. The practice bombs are dropped unfuzed, but to ensure that the correct bombing drill is carried out in practice, the Fuzing selector must be placed in the TAIL or TAIL AND NOSE position before the bombs can be dropped. This action energizes relays in the carriers, which control the supply to the auto-selector and release slips also in the carriers. Depression of the bomb release push-switch will now energize the firing relay to feed the auto-selectors in a similar manner to that for the normal bomb release circuit and a bomb will be released from one of the carriers, the bomb dropping sequence being controlled by the auto-selectors. The earth return for the relays and release gear in the carriers is via the carrier structure and pylon hook.

15. Depression of the CLEAR AIRCRAFT push switch, while the practice bomb carriers are fitted and the NORMAL/PRACTICE switches are in the PRACTICE position, will energize the pylon stores jettison relay in the usual manner. With the relay energized, a supply will be made to the jettison solenoids, via the

NORMAL/PRACTICE switches, and the jettison solenoids will operate the mechanical release plungers on each release slip. The release hooks will thus open mechanically to allow the practice bomb carriers to fall free. The release slips will not operate electrically under these conditions as the supply to them is isolated at the open isolation switches in each pylon.

R.P.firing

16. The rocket projectiles are carried on four sets of Mk.12 Type 3 launchers located below each outer wing and the firing circuit is designed to fire up to 24 projectiles in salvos of 2, 4, 6 or 8 as required. The installation employs the Type 2 uniselector firing system, which has two methods of operation, the first being normal fire and the second ripple fire. The method of operation is determined by a RIPPLE/NORMAL switch and the size of each salvo is selected by an R.P.selector switch. The firing distribution box is mounted on frame 19 adjacent to ARM J.B.1 and contains a number of control relays and an eight-level 25-pole uniselector switch, of which only seven-levels are used. Connection to and from the distribution box is made by three plugs. The centre plug is unmarked and is in connection with the pilot's control switches, while one or the other of the remaining two plugs, marked PAIRS and SINGLES respectively, feeds the firing circuits of the rocket launchers. On this aircraft only the plug marked SINGLES is used and the other is covered with a protective cap as it is not used on Hunter aircraft (para.22). The R.P. selector and RIPPLE/NORMAL switches are mounted together on a panel located in the cabin. The rippling relay, uniselector re-set switch and its magnetic indicator are contained in ARM J.B.1. The R.P. assessment relay, linked with the camera gun circuit is located in ARM J.B.2.

Operation

17. The projectiles are fired by depression of the bomb/R.P. push-switch, after the BOMB/R.P. selector

switch has been placed in the R.P. position and the firing method and salvo size selected by operation of the RIPPLE/NORMAL and R.P. selector switches. As a full description, together with the operation of the Type 2 unselector firing system is contained in A.P.4343X, Vol.1, Sect.16, it is not considered necessary to duplicate this information, but to only give a brief summary of the two firing methods.

18. When the aircraft is airborne the bomb/R.P. push-switch and the BOMB/R.P. selector switch are both supplied as described in para.10, thus when the BOMB/R.P. selector switch is placed in the R.P. position a supply is made to the R.P. assessment relay, R.P. selector switch, firing distribution box and to a contact in the bomb/R.P.firing relay. The R.P. assessment relay is thus energized in preparation for feeding the camera hold-on circuit (para.28) and the R.P. selector switch will feed the firing distribution box when placed in either the four, six or eight position. On position two, the R.P. selector switch is out of circuit.

19. When the firing switch is depressed, the firing relay is energized and a supply made to the RIPPLE/NORMAL switch, which when in the NORMAL position feeds the firing distribution box so that the unselector immediately fires a single salvo of projectiles. The size of the salvo depends on the position of the R.P. selector switch, i.e. in position 8, depression of the firing switch will fire a salvo of eight projectiles. After firing, the system will re-set ready for a further salvo, which may be the same as already fired or changed by further operation of the R.P. selector switch.

20. When the firing switch is depressed with the RIPPLE/NORMAL switch in the RIPPLE position, the supply to the firing distribution box is taken through the rippling relay. The unselector and relay then operate together so that the projectiles are fired continuously, in salvos, as selected by the R.P. selector switch, i.e. 2, 4, 6 or 8 at a time,

until the armament is expended or the firing switch released.

21. The re-set switch is used to re-set the unselector in the firing distribution box, prior to re-arming. The indicator will operate when re-setting is complete and will be de-energized when the re-set switch is released.

22. The firing distribution box has provision to enable the size of the salvos, as selected, to be halved for training purposes and this is the reason for the plugs on the box which are marked PAIRS and SINGLES respectively. Hunter aircraft, however, do not use this facility and the cable assembly supplying the launchers MUST be connected to the SINGLES plug, as the wiring to the launchers is such that when connected in this manner the normal operational firing order is obtained. If connection is made to the PAIRS plug, an incorrect firing sequence will result, under certain conditions, with the possibility of damage to the aircraft.

Pylon stores jettison

23. Provision is made for jettisoning the drop fuel tanks and external stores from each inboard and outboard pylon by operation of push-switches located in the cabin. The jettison mechanism in the inboard pylons is fully described in para.9, being that used for bomb release. The gear in the outboard pylons is similar, consisting of a release slip, cock test socket and jettison solenoid located in each pylon. The mechanism is operated by depression of the OUTBOARD PYLON STORES jettison push-switch, which is mounted on the bomb/R.P. control panel or automatically, via the jettison relay, when the CLEAR AIRCRAFT push-switch is depressed. Provision is also made in the inboard pylons for the fitment of a jettison gun, the wiring for this being stowed at present.

Operation

24. Depression of the OUTER PYLON STORES jettison push-switch will energize the release slips in each outer pylon and open the release hooks. At the same time a supply will be made to the jettison solenoid, which will be energized and operate the mechanical release plungers on each release slip to open the release hooks mechanically if they have not already opened electrically. Depression of the CLEAR AIRCRAFT push-switch will energize the jettison relay and operate the jettison mechanism in the inboard pylons as described in para.12. At the same time, a set of contacts in the jettison relay, which are in parallel with the OUTER PYLON STORES jettison push-switch, will close and automatically operate the jettison gear in each outer pylon. The operation of the cock test sockets of the outer pylons is similar to those in the inboard pylons as described in para.13.

G.45B camera

25. The camera gun is located on a mounting platform inside the fuselage nose structure at the top just forward of frame 3 and is focused through a vision tube riveted around an orifice in the skin. The camera is controlled by the gyro caging and camera relay located on the leg panel and is operated whenever the gun firing trigger is pulled to fire the guns or, independently of the guns, by depression of the camera push-switch at the top of the control column handgrip. During an R.P. attack the camera is also used to photograph the target up to the moment that projectiles are released. The camera lens and body heaters are both controlled by the CAMERA MASTER switch, which is located on the leg panel adjacent to the battery, pressure head heater and engine master switches. A switch, used to select the correct iris opening during SUNNY or CLOUDY weather, is located on the starboard instrument panel. When the camera is not fitted, a blanking plate, normally stowed on a bracket on

frame 2, is fitted to the aperture in the nose structure.

Operation

26. The camera lens and body heaters are both on when the CAMERA MASTER switch is closed, the body heater being thermostatically controlled to maintain the camera at its correct operating temperature. The supply to the camera push-switch on the control column handgrip is taken from the gun firing circuit fuse, via the safety plug and alighting gear compression switches. When the aircraft is airborne, the compression switches make contact and complete the supply to the camera push-switch, thus when the switch is depressed to operate the camera, independently of the guns, the supply is conducted to the coil of the gyro caging and camera relay. With the gyro caging and camera relay energized a supply is made from the camera circuit fuse to the camera operating solenoid, via a pair of contacts in the relay and the camera will operate until the push-switch is released to de-energize the relay. If the gun sight and camera recorder are in the combat position at the time the camera gun is operated, a further pair of contacts in the gyro caging and camera relay will complete the supply to the solenoid controlling the camera recorder claw mechanism, as described in Sect.5, Chap.2 of this volume, and the camera recorder will operate.

27. When the gun firing trigger is pulled, the gun firing relay is energized and a supply is made via contacts 1-1a to energize the gyro caging and camera relay. With the gyro caging and camera relay energized, a supply is made to the camera operating solenoid in the same manner to that described in para.26. The camera will, therefore, operate as the guns are fired to photograph the target, until the gun firing trigger is released and de-energizes the gun firing relay, which in turn de-energizes the gyro caging and camera relay. The camera recorder will also

operate as the guns are fired, as described in para. 26.

28. When making an R.P. attack, the tactics employed are to photograph the target up to the moment that the projectiles are released and thus, it is necessary to start the camera before firing the projectiles and keep it operating until the projectiles are released. This is accomplished by a hold-on circuit through the gyro caging and camera relay, which is supplied via the R.P. assessment relay, and controlled by the BOMB/R.P. selector switch and bomb/R.P. firing relay. When the BOMB/R.P. selector switch is set to the R.P. position, a supply is made to energize the R.P. assessment relay, which in turn makes a supply to the contacts of the gyro caging and the camera relay in preparation for feeding the camera hold-on circuit. Depression of the camera push-switch will energize the gyro caging and camera relay, as described in para. 26 and the relay will be held energized by the supply passing through its own contacts from the R.P. assessment relay and through contacts in the de-energized bomb/R.P. firing relay. The camera will, therefore, continue to operate after the camera push-switch is released. On firing the rocket projectiles, by pressing the bomb/R.P. push-switch on the top of the control column handgrip, the bomb/R.P. firing relay is energized. This breaks the hold-on circuit of the gyro caging and camera relay, which will be de-energized and stop the camera. To start the camera in preparation for a further attack, the camera push-switch must be operated again.

SERVICING

General

29. For general servicing of the electrical system as a whole reference should be made to Group A.1. of this chapter. All the components should be kept clean and examined periodically for signs of damage

and to ensure that they are securely mounted. Apart from the standard routine serviceability and bench testing of the components, as described in the appropriate Air Publications, quoted in para. 1, no further servicing should be necessary.

REMOVAL AND ASSEMBLY

General

30. Once access has been obtained, the removal and assembly of the components forming the armament services should present no unusual difficulties. The removal of the gun firing panel and ARM junction boxes, which carry the majority of the components is fully described in Group A.2 of this chapter, while the removal of the gun package is covered in Section 7, Chapter 3 and the removal of the pylons in Sect. 3, Chap. 2 of this volume. The location of and means of access to all the components is indicated in Group A.3 of this chapter.

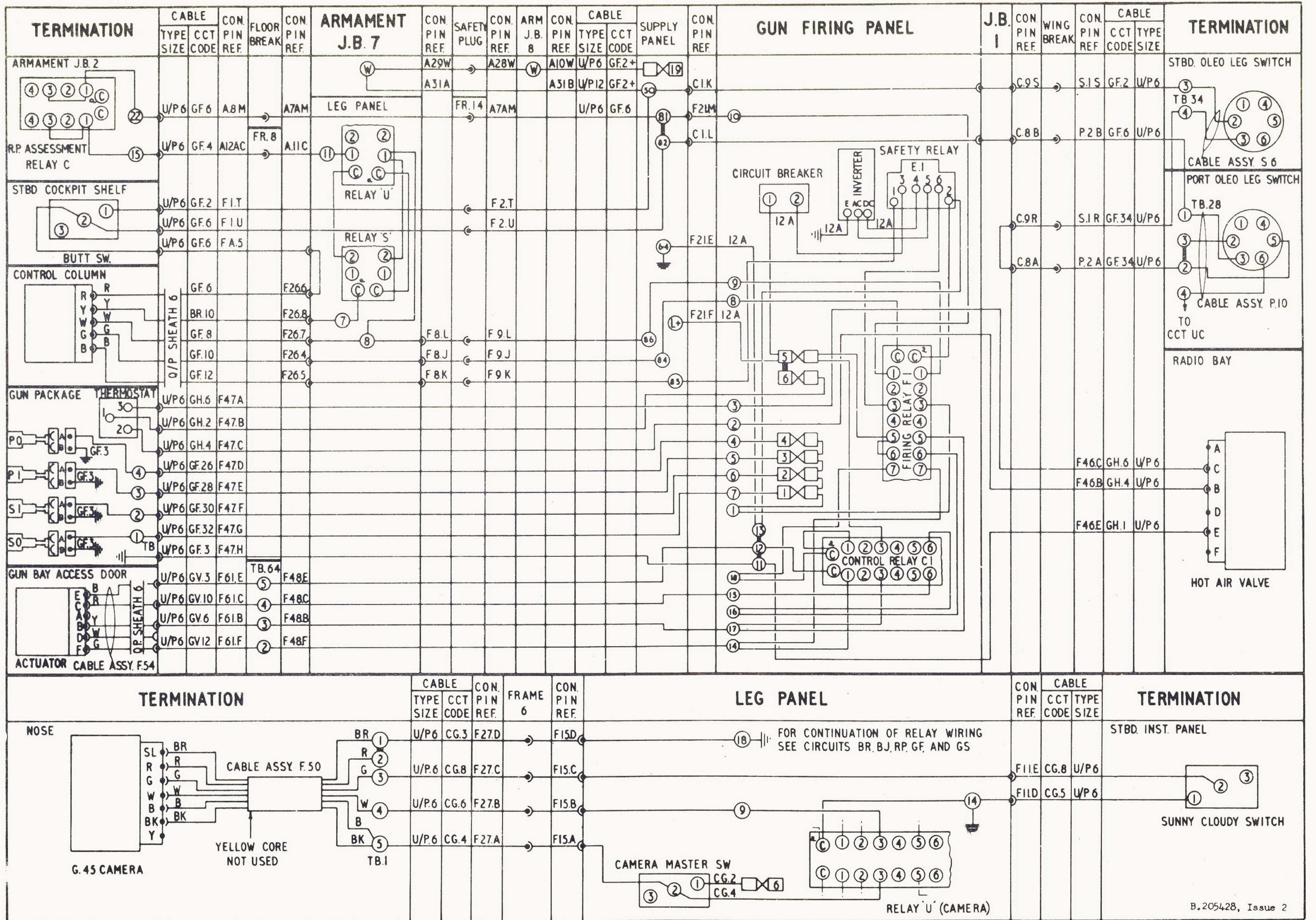

FIG. 1 GUN FIRING, VENTILATION, HEATING AND CAMERA (ROUTING)

RESTRICTED

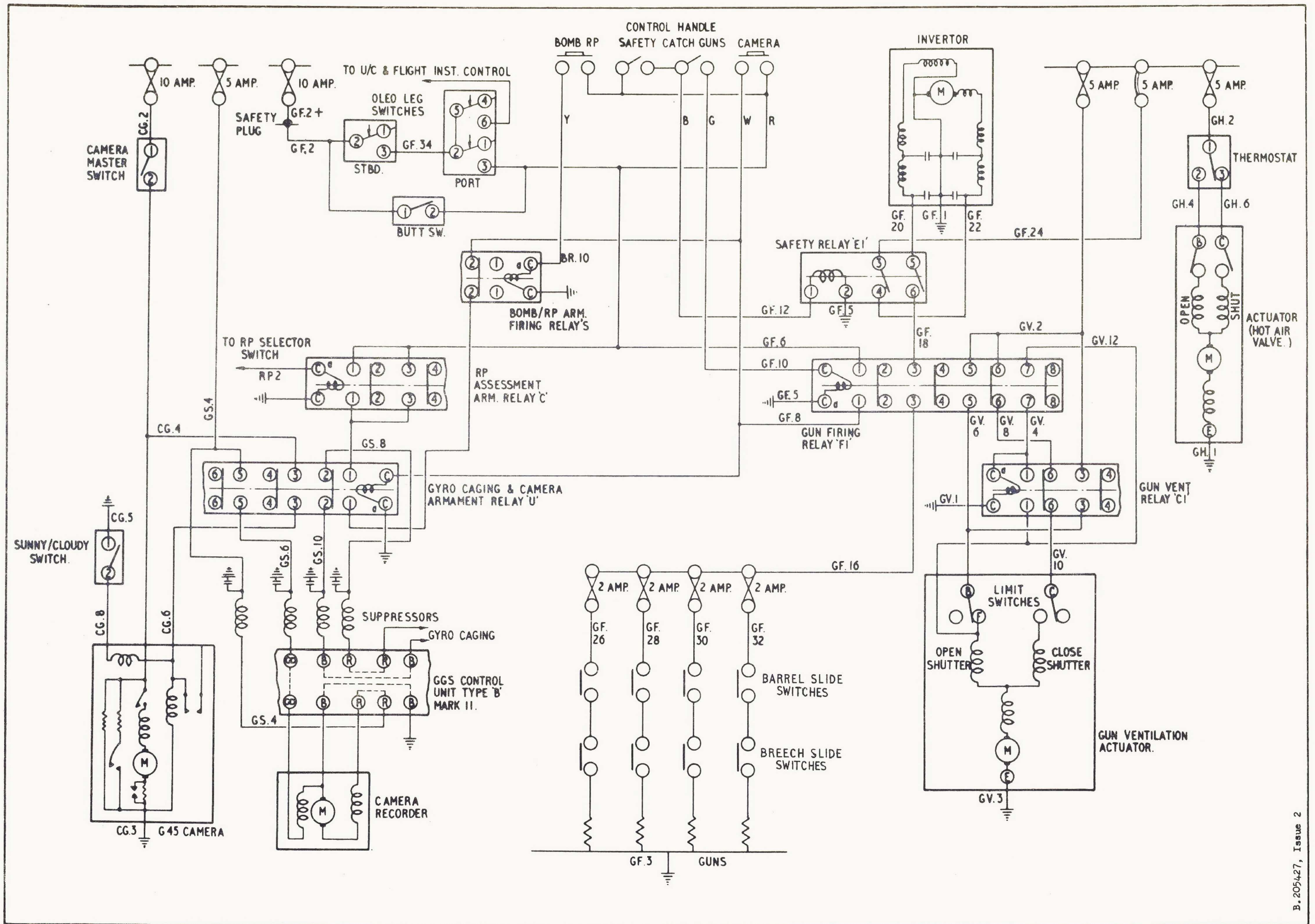
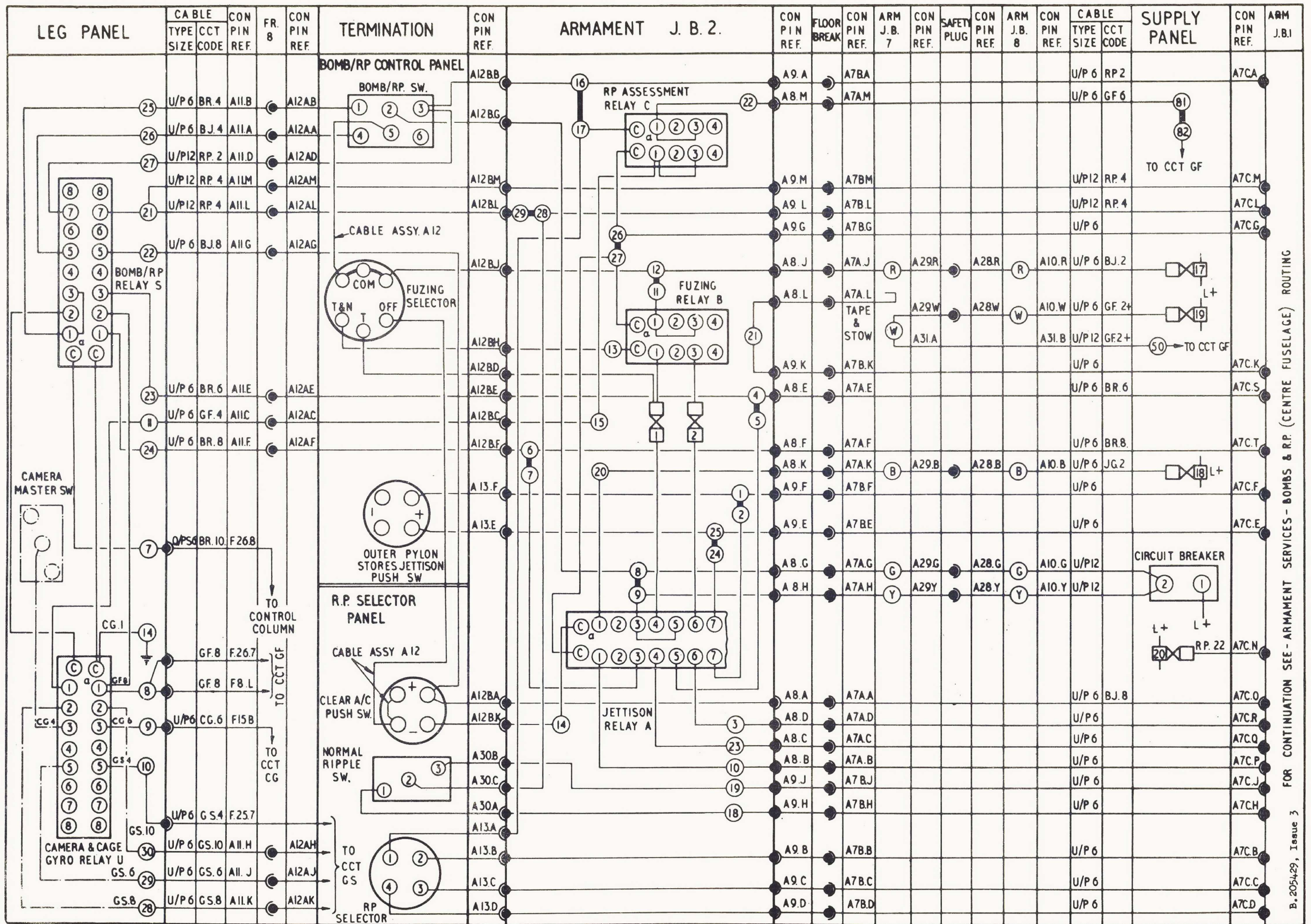

FIG. 2 GUN FIRING, VENTILATION, HEATING AND CAMERA (THEORETICAL)

RESTRICTED



FOR CONTINUATION SEE - ARMAMENT SERVICES - BOMBS & R.P. (CENTRE FUSELAGE) ROUTING

B.205429, Issue 3

FIG. 3 BOMBS AND R.P. (ROUTING-FRONT FUSELAGE)

RESTRICTED

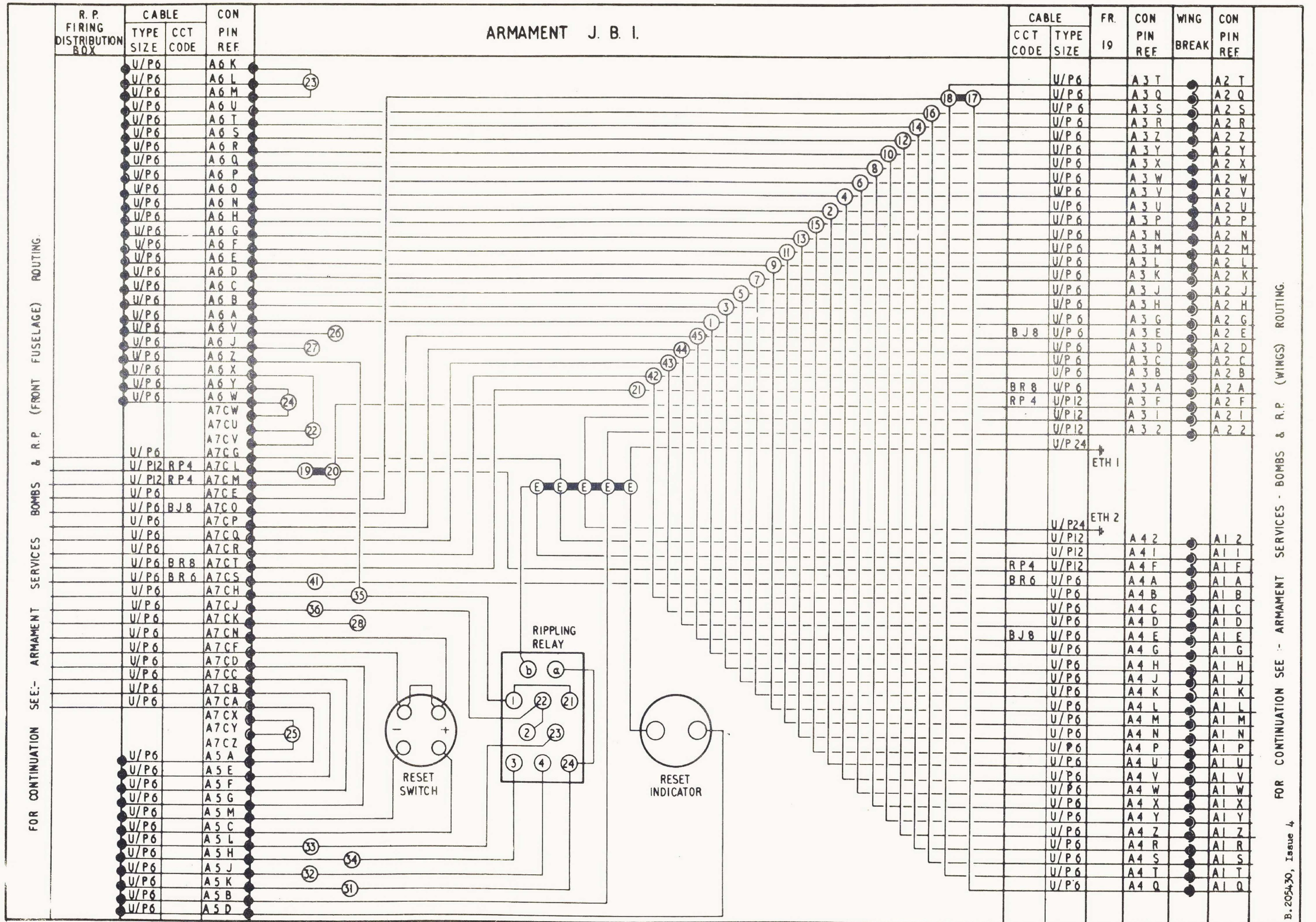

FIG. 4 BOMBS AND R. P. (ROUTING-CENTRE FUSELAGE)

RESTRICTED

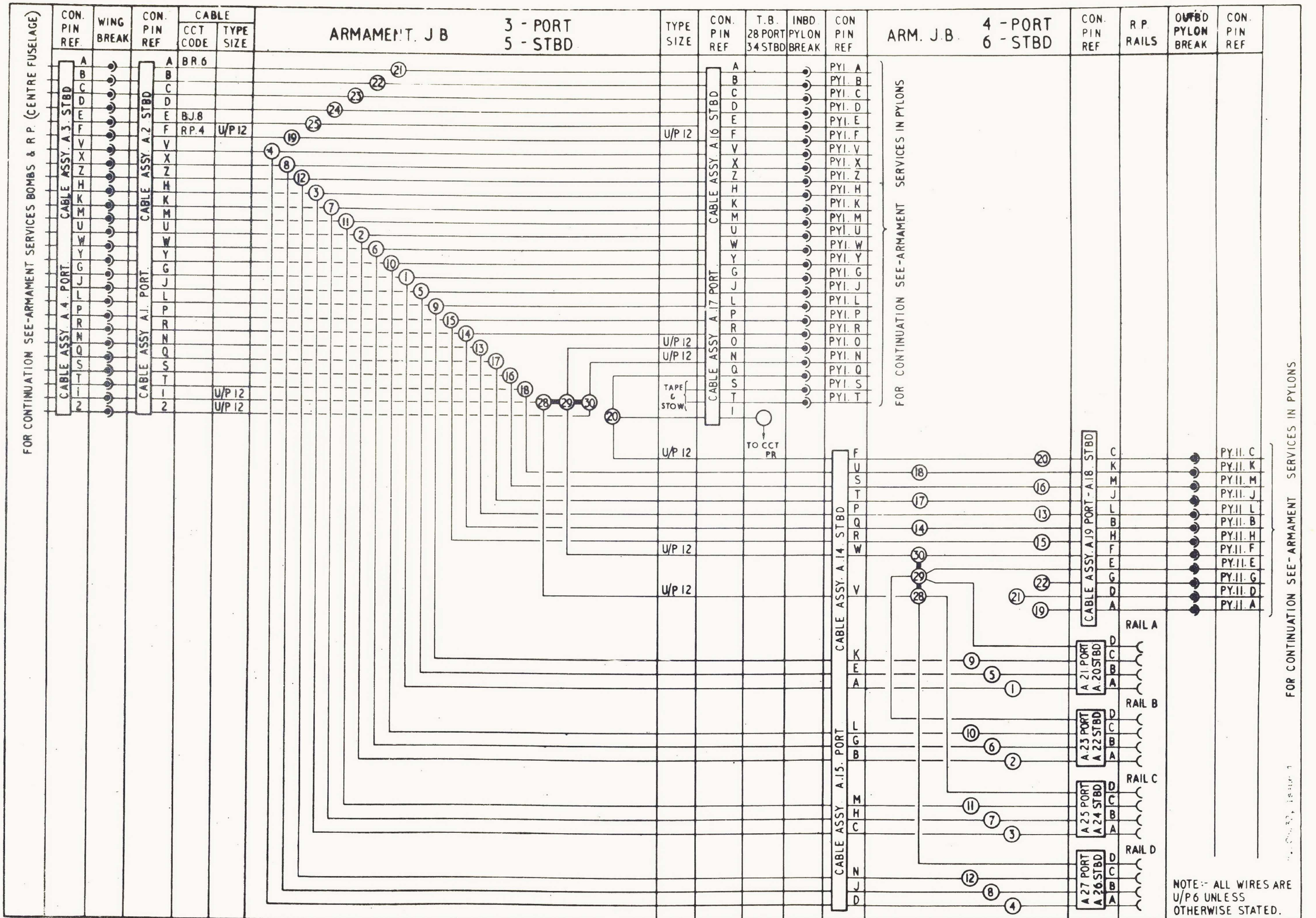

FIG. 5 BOMBS AND R.P. (ROUTING-WINGS)

RESTRICTED

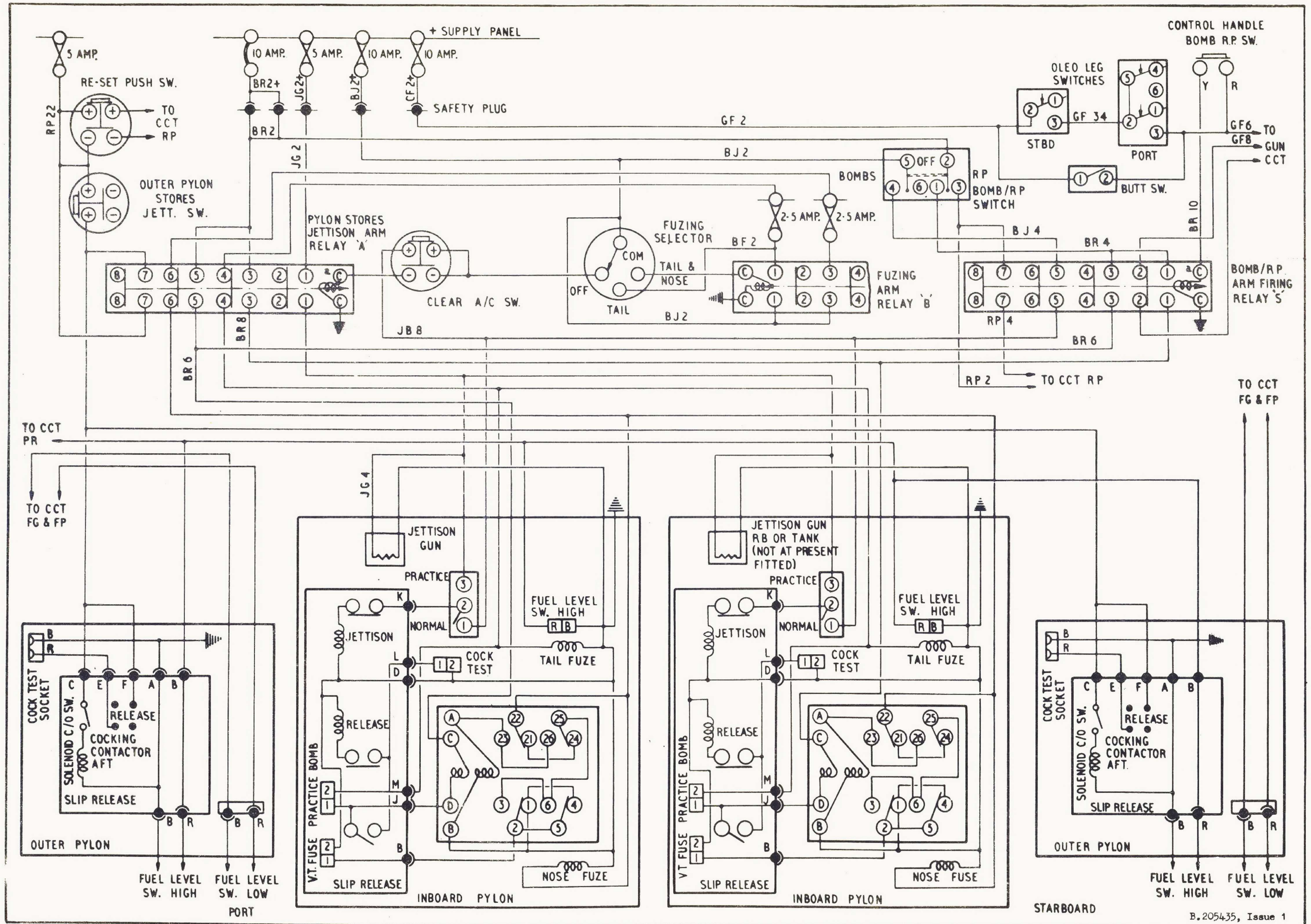

FIG. 7 BOMBS AND PYLON STORES (THEORETICAL)

RESTRICTED

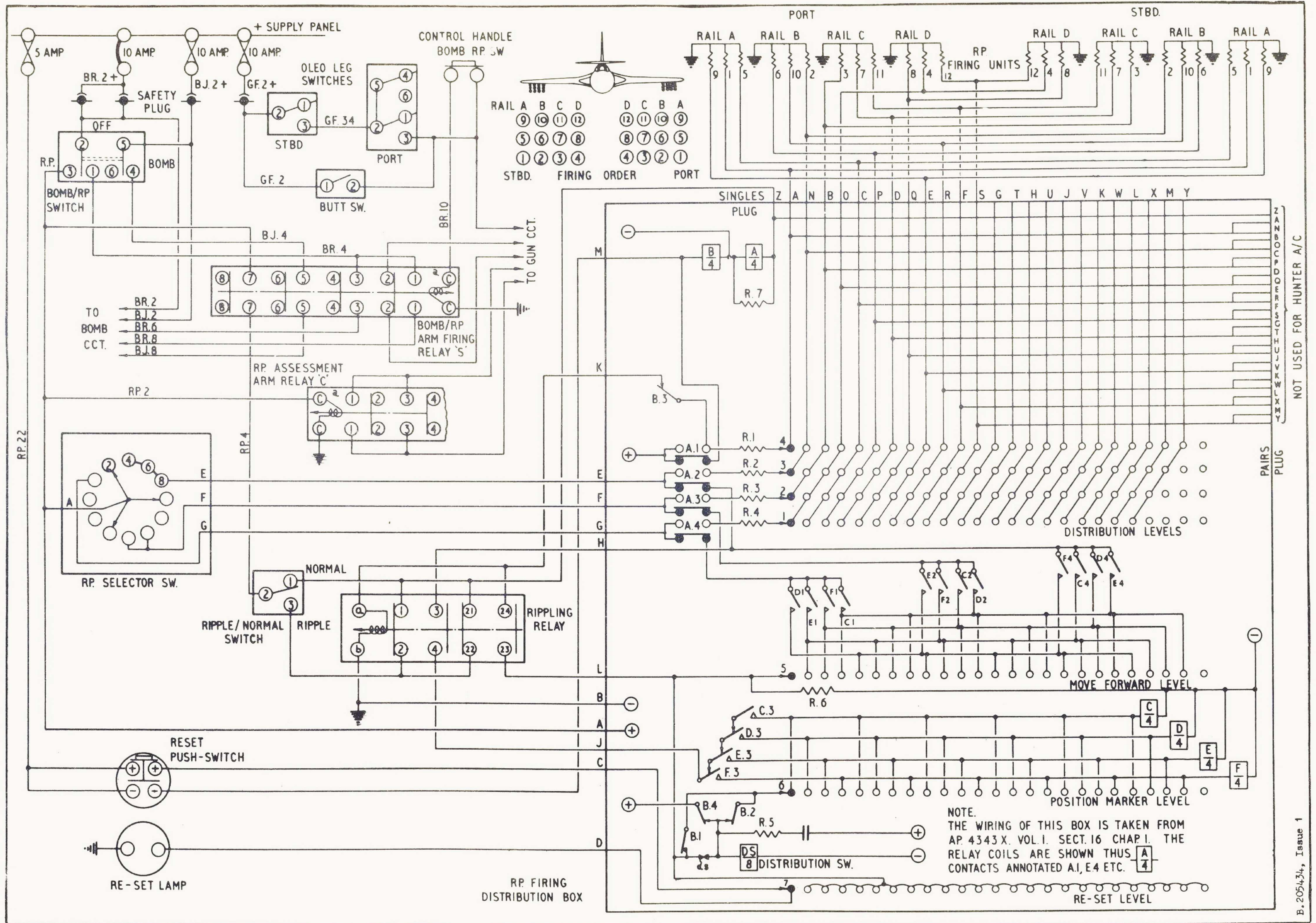

FIG. 8 R.P. (THEORETICAL)

RESTRICTED



The P/Q Family

Why "P/Q"?

The P/Q family of Masks

MCA "Warning Connector"

P/Q 1

P/Q 2

P/Q 4

V-Type

V-Type

V-Type

V-Type

A-Type

V-Type

A-Type

A-Type

Quick Don

A-13A/1

A-13A/2

This file was downloaded from the RTFM Library. Link: www.scottbouch.com/rtfm Please see site for usage terms, and more aircraft documents.