

CHAPTER 2

R.P. EQUIPMENT

LIST OF CONTENTS

<u>Para.</u>	<u>Para.</u>
Introduction	1
Launcher rails	2
Mounting posts	3
R.P. controls	6
Attachment of removable parts	7
Armament safety break	9
	10
	ILLUSTRATIONS
	<u>Fig.</u>
	1
	2
	3

Introduction

1. This chapter contains a description of the R.P. installation on this aircraft, together with details of the removable parts. Information on the gyro gun sight and G.45 camera will be found in Sect. 7, Chap. 3, and a description of the electrical

circuit, complete with wiring diagrams in Sect. 5, Chap. 1, Group G.1. Further information on rocket projectile installations generally, will be found in A.P. 2802A, (Second Edition) Vol. 1.

Launcher rails

2. The rocket projectiles are carried either singly or in tiers of up to three on each of four sets of Mk.12, Type 3 launcher rails under each outer wing. The alternative types of R.P. store that may be fitted and the quantity carried at each station are shown on fig.3. The launcher rails are identified as rails A, B, C and D on each wing, rail A being outboard. The launcher rails are located on the underside of the wings as follows:-

Launcher rail A - outboard of rib R and across rib S.

Launcher rail B - between nose rib Q and rib R (across main spar, necessitating the removal of outboard pylon before the installation of the rail can be effected).

Launcher rail C - between nose rib N and interspar rib Q (across juncture of nose rib P and interspar rib P with main spar).

Launcher rail D - between nose rib L and interspar rib N (across junction of rib M with stringer).

Mounting posts

3. Each launcher rail is attached to a pair of mounting posts which are themselves attached to the wing structure. The mounting posts are of tubular structure and have a top section which is machined at an angle to conform with the contour of the upper surface of the wing. Each post passes through the wing structure and terminates on the undersurface with an eye-end to which the launcher rail is attached by means of a high-tensile steel bolt. The front posts are of high tensile steel, while the rear

posts are of light alloy and are slotted at their lower ends to permit the assembly of the electrical cables which run from the wings to the rails. The posts are secured to the wing by means of a knurled bronze nut which screws on to the threaded portion above the eye-end. The bronze securing nuts are machined to a spherical shape at one end to fit into a corresponding recess of a light alloy washer interposed between the nut and the wing skin; thus allowing the washer to align itself with the under-surface of the wing. Each bronze nut must be hand-tightened only.

4. Owing to the variation in depth and contour of the aerofoil, the posts, four front and four rear for each wing, are not interchangeable, either port or starboard, or with each other on their respective wings (Para.8, sub-para.1). A cable cover fabricated from light alloy sheet, is attached to each rear post and extends rearwards to clamp over the launcher rail. These cable covers are interchangeable.

5. Cover plates are provided to seal the holes vacated by the mounting posts when the R.P. installation is removed. The plates, which are provided with captive nuts, lie flush with the outer surface of the wing when bolted in position. A blind hole in each plate is threaded to receive a bolt, or piece of screwed rod, which is used to insert the plate into the post hole during the fitting of the plate. It also serves to hold the plate in position while the securing bolts are fitted, after which, of course, the bolt, or screwed rod is removed.

R.P. controls

6. The R.P. installation employs the Type 2 uniselector firing system which has two methods of operation, the first being normal fire and the second ripple fire. The firing distribution box is

mounted on frame 19 adjacent to ARM J.B.1., which contains the rippling relay, the uniselector re-set switch and magnetic indicator. The rocket projectiles are fired by depressing the Bomb/R.P. push switch on the control column handgrip, after the Bomb/R.P. selector switch on the cabin port shelf has been placed in the R.P. position and the firing method and salvo size selected by operation of the ripple/normal and R.P. selector switches on the R.P. selector panel above the port instrument panel. The twenty four projectiles may be fired in salvos of 2, 4, 6 or 8 according to requirements and selection.

Attachment of removable parts

7. The front and rear mounting posts, launcher rails and the cable covers comprise all the removable parts. Before commencing to install the mounting posts, the cover plates (para.5), which normally seal the mounting post holes in the wings, must be removed and their attachment bolt holes sealed after removing the plates by using the existing bolts and suitable nuts in lieu of the captive nuts on the plates. If the outboard pylon is fitted and it is desired to install R.P., this pylon must be removed and the necessary blanking plates fitted in lieu (Sect.2, Chap.2).

8. When assembling the mounting posts, the following points should be noted:-

- (1) Ensure that the mounting posts are assembled in their correct position in relation to the wing section and port and starboard handing etc. (The posts are engraved for port and starboard and have a numeral to indicate their respective rails. Similar indication is stencilled adjacent to the post holes on both the upper and lower surfaces of the wings).

- (2) Prior to fitting the posts, lubricate the thread on the post, the spherical end of the nut and the spherical recess in the washer with grease Specification X.G.275 (Stores Ref.34B/222).
- (3) Tighten the bronze securing nuts by hand only.
- (4) Fit the launcher rails to the eye-ends of the posts, using the special high-tensile steel bolts provided and, in the case of the rear posts, also fit the cable guards which are secured by the same bolts in the eye-ends.
- (5) When the assembly is complete, use 22 s.w.g. non-corrodible wire to Specification DTD.189 or DTD.161 to wire-lock the knurled nuts.

In the case of the front post, the wire is passed through the hole in the post, located between the threaded portion of the post and the eye-end. In the case of the rear post, the wire is passed through the hole in the end of the high-tensile steel bolt that secures the rail to the eye-end, the wire also serving to lock the nut of the rail locking bolt in the eye-end. The nut of the rail locking bolt in the eye-end of the front post must be secured with a split pin.

Armament safety break

9. An armament safety plug, located in the port stub wing, is accessible via a small hinged door fitted in a panel under the wing, just forward of the main spar pin joint. The door is provided with a toggle fastener to facilitate access. The plug, which is fitted with a red warning pennant, must be removed before R.P. are fitted and should only be

put back immediately prior to take-off from the runway.

NOTE...

The pennant must NOT be removed from the plug.

Re-arming

10. The procedure for re-arming is given in A.P.2802A, (Second Edition) Vol.1, but the following should be noted:-

- (1) When the aircraft is being armed with 5 in. H.V.A.R. projectiles, these are to be mounted in single tier on rails A, B and D only, leaving rail C unloaded (Fig.3).

- (2) On aircraft in which Mod.H.427 has not been incorporated, at launcher rail B, the electrical cable connecting from the wing to the store must be passed outboard and forward of the rear mounting post in the wing. All slack cable is to be pulled back and stowed in the fairing and rail to clear the aileron control linkage.

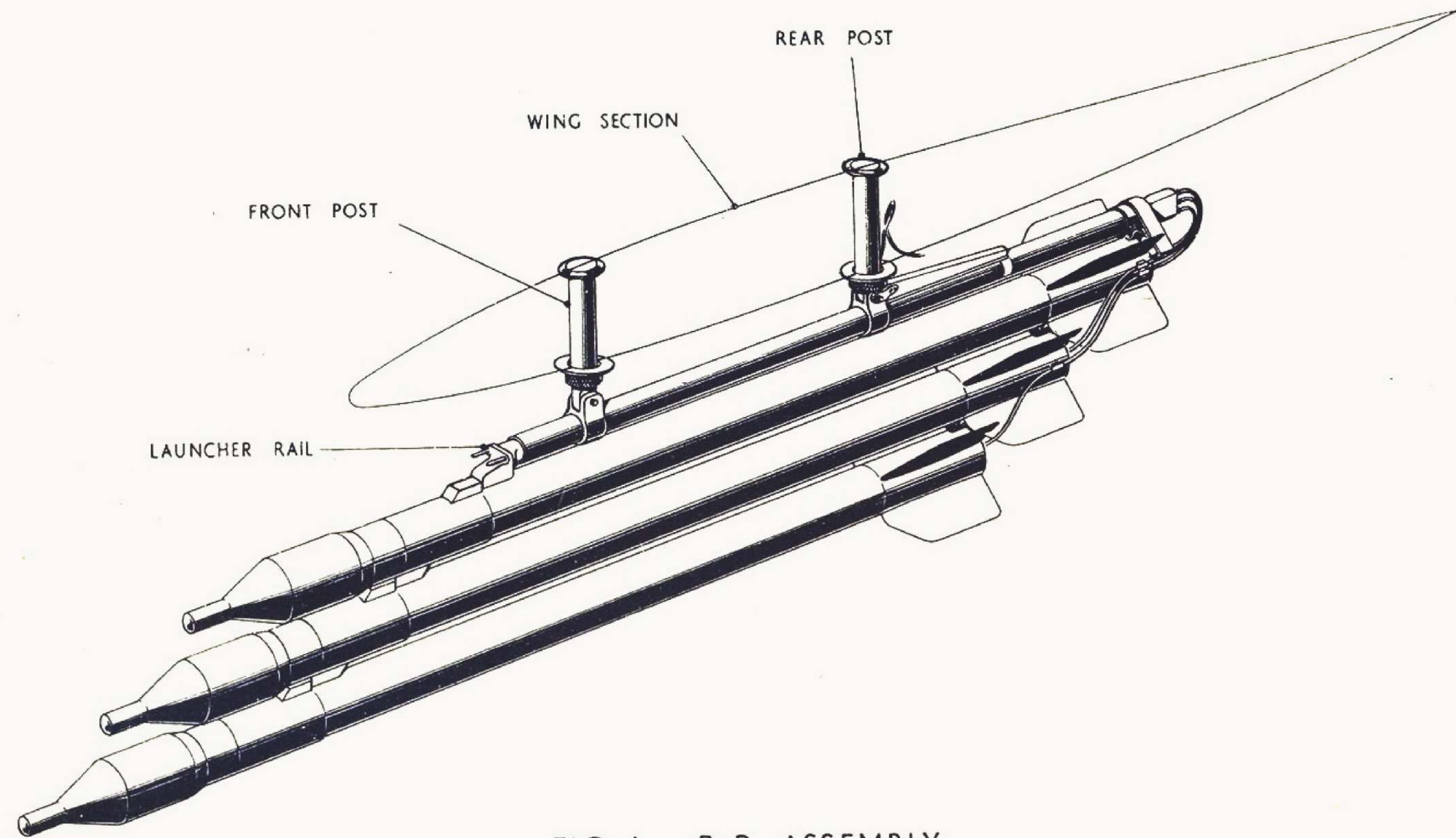
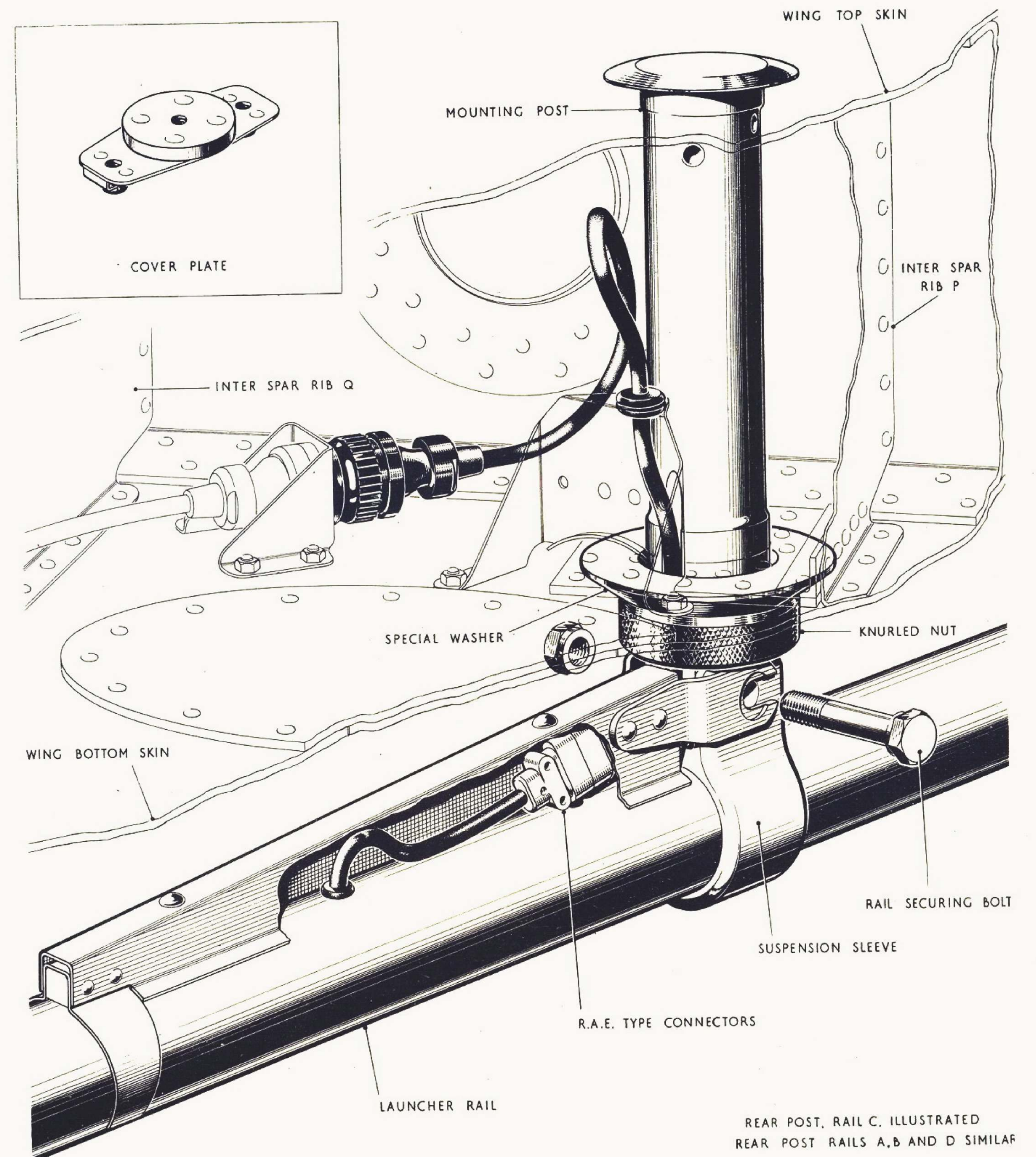

FIG. 1 R.P. ASSEMBLY



REAR POST, RAIL C. ILLUSTRATED
 REAR POST RAILS A, B AND D SIMILAR

FIG. 2 LAUNCHER RAIL ATTACHMENT

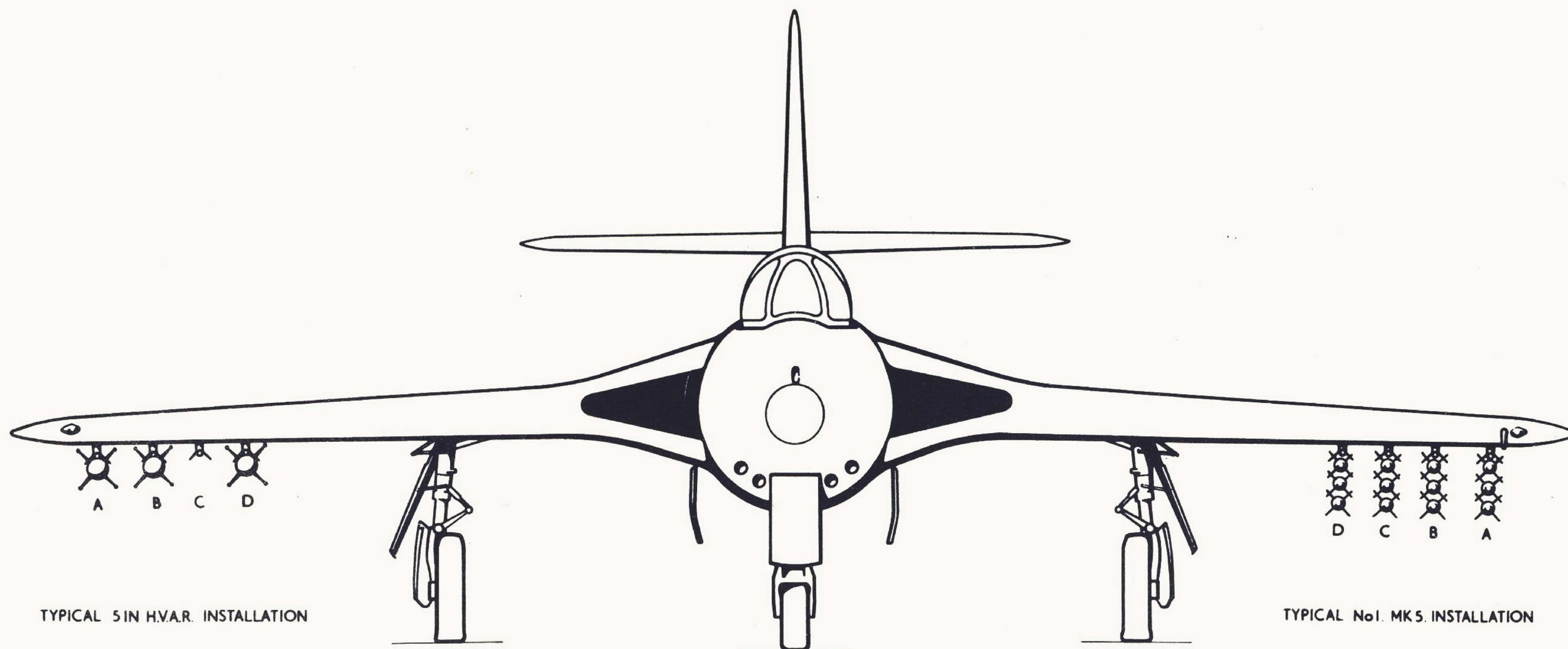

FIG.3 R.P. INSTALLATION

Typical alternative R.P. Stores

Type of R.P.	Max. Qty. Carried
12 lb. Head, 3 in. Motor No.1 Mk.5 (OR.1099)	All stations, triple tier
18 lb. Head, 3 in. Motor No.1, Mk.5 (OR.1099)	All stations, triple tier
25 lb. Head, 3 in. Motor No.1, Mk.5 (OR.1099)	All stations, triple tier
60 lb. Head, 3 in. Motor No.1, Mk.5 (OR.1099)	All stations, single tier
5 in. H.V.A.R. (38 lb. or 52 lb. Head)	Three stations, A, B and D in each wing. Single tier.

The above installations may be carried with or without drop tanks carried on inboard pylons.

This file was downloaded
from the RTFM Library.
Link: www.scottbouch.com/rtfm

Please see site for usage terms,
and more aircraft documents.

