

CHAPTER 3

TAIL UNIT

LIST OF CONTENTS

	<u>Para.</u>		<u>Para.</u>
Introduction	1	Elevators	8
DESCRIPTION		SERVICING	
General	2	General	9
Fin	3	Lubrication	10
Fin attachments	4		
Rudder	5	REMOVAL AND ASSEMBLY	
Tail plane	6	General	11
Tail plane attachments	7		

LIST OF ILLUSTRATIONS

	<u>Fig.</u>		<u>Fig.</u>
Tail unit	1	Removal of elevator	8
Removal of rudder	2	Split lever connecting port and starboard elevators and inner hinge bearing	9
Rudder operating lever and bottom hinge ...	3	Removal of tail plane	10
Attachment of rudder sling	4	Plug for tail plane slinging hole	11
Removal of fin	5	Attachment of tail plane sling	12
Rear fin attachment and tail plane hinge bracket and cap	6	Attachment of jack lever to tail plane actuator	13
Fin attachment - front	7		

Introduction

1. This chapter contains a general description of the tail unit, together with the servicing information necessary to maintain the structure in

an efficient condition. Illustrations showing the method of slinging and dismantling the structure into its major components are also included.

RESTRICTED

DESCRIPTION

General

2. The tail unit (fig.1) consists of a conventional fin, rudder, tail plane and elevator assembly, mounted on the lower fin structure, which is an integral part of the rear fuselage. An anti-buffet fairing, mounted to the rear end of the fin structure, extends aft between each half of the elevator just below the rudder. The incidence of the tail plane may be varied in flight by an electric actuator, the elevators have power operated controls consisting of a hydraulic booster jack to facilitate control at high speed and the rudder incorporates a small electrically-operated trimming tab. The lower part of the fin structure is described in Chapter 1 of this Section and the tail plane, elevator and rudder controls in Chapter 4.

Fin.

3. The fin is constructed in two portions, the lower portion being an integral part of the rear fuselage structure. The upper fin consists of front and rear spars, nose ribs, inter-spar ribs and a rudder shroud, the complete structure being covered with a light-alloy skin. The rudder shroud structure, aft of the rear spar, carries the two rudder hinges and the top leading edge tip of the fin is detachable and contains the suppressed aerial for the I.F.F. installation.

Fin attachments

4. The upper fin is mounted to the lower fin and rear fuselage structure by fittings bolted to the front spar, inter-spar bottom rib and rear spar, which engage with further fittings carried at the top of frames 52 and 55. The front attachment

fitting consists of two forked eye-ended stampings which are bolted to the front spar and bottom inter-spar rib of the fin structure. These fittings engage with fork-ended stampings which are bolted to the top of frame 52 and the assembly is secured by special bolts. The rear attachment fitting consists of two forked eye-ended stampings which are bolted to the rear spar and bottom inter-spar rib, one on each side of the centre-line. These fittings engage with twin fork-ends at the top of a large attachment stamping bolted to frame 55 and the assemblies are secured by special bolts. The stamping, bolted to frame 55, incorporates a trunnion on each side on which the tail plane pivots.

Rudder

5. The rudder is hinged to the upper fin structure at two points and consists of a main spar, sub-spars, nose ribs, main ribs and a trailing edge section. The structure, which is strengthened by stiffeners, is covered with a light-alloy skin and incorporates distributed mass-balance and a small trimming tab. The hinge blocks and operating lever are bolted to the main spar and the mass-balance weights project forward on brackets attached to the rudder nosing, which is formed by the main spar and the nose ribs. The trimming tab is located in the lower trailing edge on a piano type hinge and is operated by a small electric actuator bolted to the forward face of the main spar.

Tail plane

6. The tail plane is an all-metal cantilever structure of swept back design, which is constructed in one piece and provided with variable incidence control. Basically it consists of front and rear spars with nose ribs, inter-spar ribs and tail ribs, together with an elevator shrouding; the complete

RESTRICTED

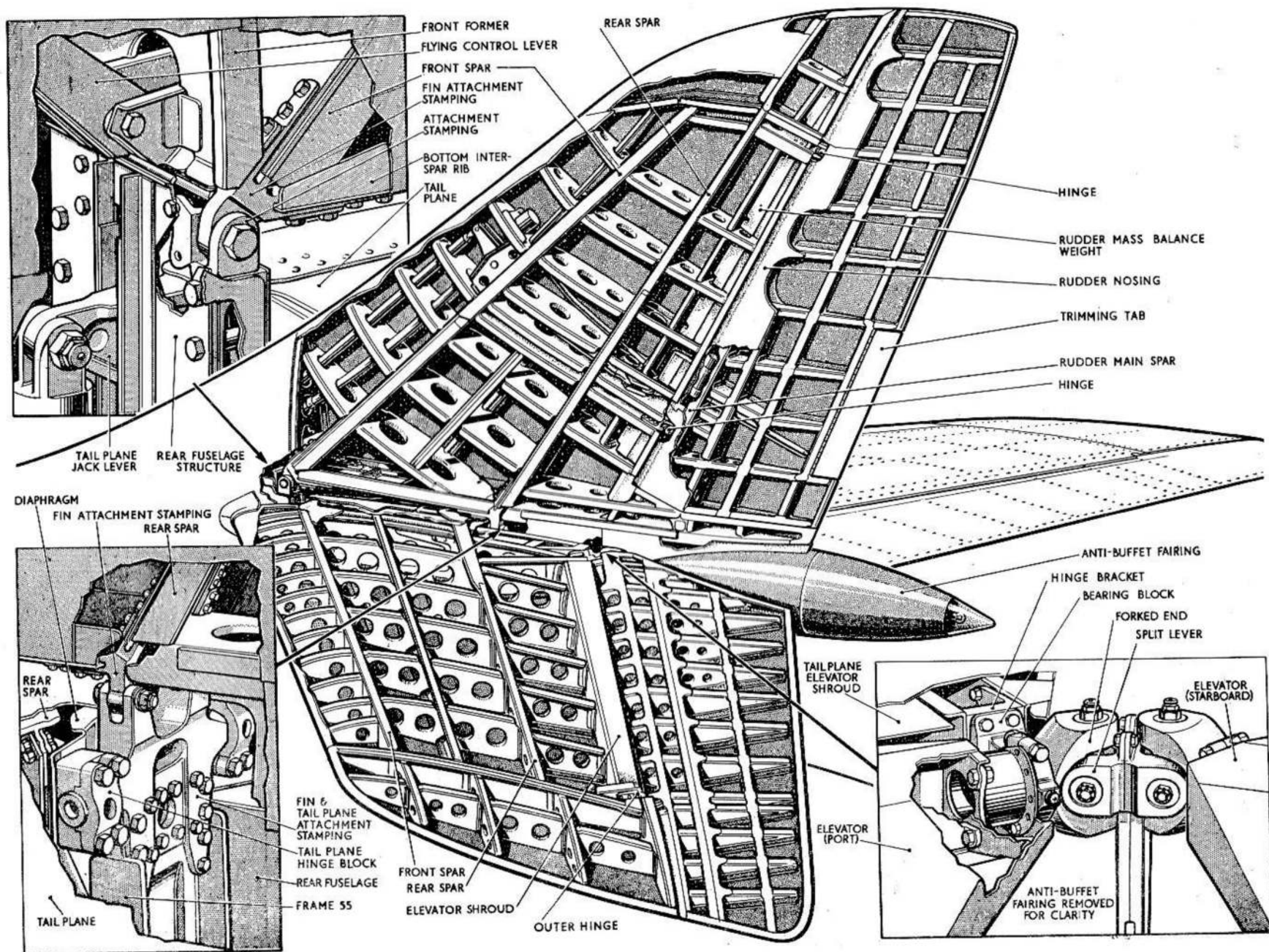

FIG. 1 TAIL UNIT

assembly being covered with a light-alloy skin. The unit is anchored at the front spar to an electrically-operated actuator and hinged at the rear spar on trunnions at the top of frame 55. Operation of the actuator, thus raises or lowers the leading edge to provide the variable incidence control. The elevator shroud structure carries the inner and outer hinges for each elevator.

Tail plane attachments

7. The tail plane is mounted to the lower fin and rear fuselage structure by fittings bolted to the front and rear spars. The forward fitting consists of a large lever which is bolted to the forward face of the front spar centre section member at the centre-line rib and anchored at its forward extremity to the extensible shaft of the incidence controlling actuator situated in the lower fin structure between frames 51 and 52. The rear fittings consist of hinge blocks secured to mounting blocks which are bolted to the tail plane rear spar and hinge ribs on each side just outboard of the centre-line rib. These hinge blocks pivot on trunnions projecting from each side of the fin and tail plane attachment stamping bolted to the top of frame 55.

Elevators

8. Each elevator consists of a main and sub-spar, together with nose ribs, inter-spar ribs, tail ribs and a trailing edge member, the complete structure being covered with a light-alloy skin additionally strengthened by a top and bottom stiffener. The main spar carries the outer hinge, together with the inner hinge and interconnection assembly. The outer hinge fig.8 consists of an adjustable ball

race mounted in a bearing block bolted to the tail plane structure. The inner hinge and interconnecting assembly (fig.1, detail & fig.9) consists of a fork-end bolted to the inner extremity of the spar, which pivots in a split bush type bearing carried in a block and cap assembly bolted to the tail plane structure. The elevators are interconnected by a split lever bolted to the fork-ends of the interconnecting assembly to form a universal joint and operating lever, which is in connection with the hydraulic booster jack unit via a control tube. The nosing, between the inner and outer hinges is filled internally with lead to form a distributed mass-balance.

SERVICING

General

9. In general, little servicing is necessary to the tail unit, apart from the servicing of the systems, which is described in the chapters of this volume complementary to the system concerned. The structure, access panels and fasteners should, however, be examined in a similar manner to that described in Chapter 2 of this section and reference should be made to Chapter 4 for the recommended procedure for rigging and setting the control surfaces.

Lubrication

10. It is necessary to lubricate the tail plane pivots when replacing or fitting a new tail plane, as indicated on fig.9, otherwise the only lubrication necessary is that required for the control surface hinges and operating gear which is described in Chapter 4 of this section.

REMOVAL AND ASSEMBLY

General

11. The removal of the fin, rudder, tail plane and elevators, is illustrated in fig.2 to 13 inclusive, the procedure being given in the keys to the illustrations. In general, the assembly of the components is a reversal of the removal procedure, but where there is any special assembly feature it is covered in the key to the illustration concerned.

REMOVAL OF RUDDER (KEY TO FIG.2)

Remove the access panels (7) port and starboard in the fin and disconnect the Bowden cable from the trim tab at the transmitter.

Remove the port access panel (6) in the fin, pull the Bowden cable through the duct and unloop.

Remove the rear end detachable portion of the fin (5) and disconnect the cable (4) from the trim tab actuator at the terminal block No.55 (fig.5).

Remove the bolt from the rudder lever connection (2) (detail fig.3) on the starboard side of the rudder.

Attach the sling (fig.4).

Take off the two nuts and remove the bearing cap at the top hinge (3) (detail fig.3) and remove the rudder.

Note...

The tab is attached to the rudder by a piano hinge and riveted, therefore it is not easily removable.

REMOVAL OF FIN (KEY TO FIG.5)

Remove the rudder (fig.2).

Disconnect all cables at terminal block 55 in the fin rear end.

Remove the anti-buffet fairing (3).

Remove the top tail plane fairings (6), port and starboard.

Remove the access panel (4), port and starboard.

Remove the access panel (1) and disconnect the flying controls, I.F.F. connector and electrical cable at terminal block 46 mounted on the front diaphragm of fin.

Attach the sling (Similar to fig.4, but different pin used).

Lower the tail plane to the fully negative position, remove the rear attachment bolts (2) (detail fig.6) port and starboard, and remove the front attachment bolts (5) port and starboard (detail fig.7) and lift off the fin.

REMOVAL OF ELEVATOR (KEY TO FIG.8)

The removal of the port elevator is described, the removal of the starboard elevator is similar. Either the port or the starboard elevator may be removed first but it is not advisable to remove the port and starboard elevators while attached to each other. The elevators may be removed without first removing either the rudder (fig.2) or the fin (fig.5). If however they have been removed, the first operational sequence below will have been carried out, in which case proceed with the next operation.

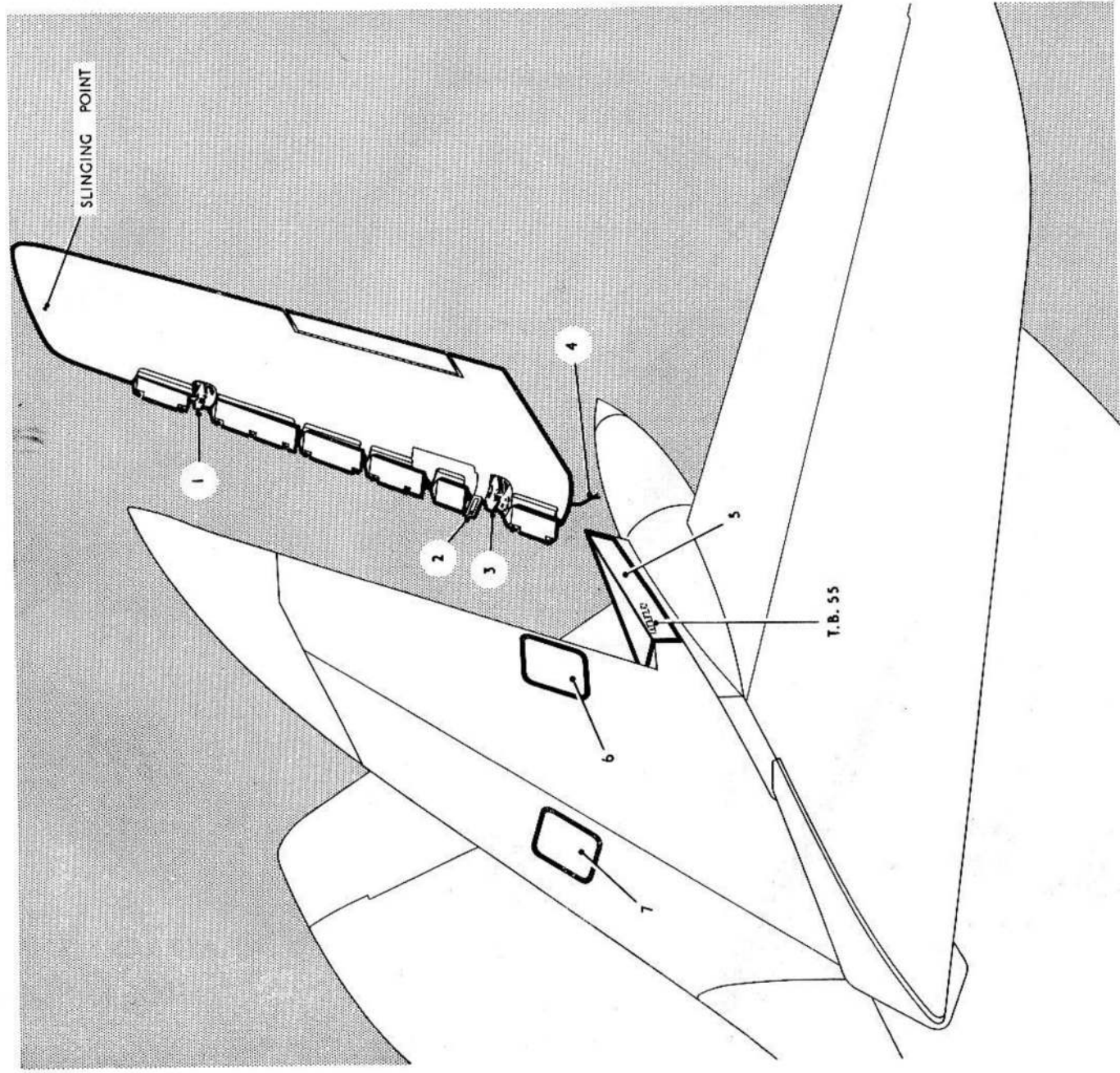

FIG. 2. REMOVAL OF RUDDER

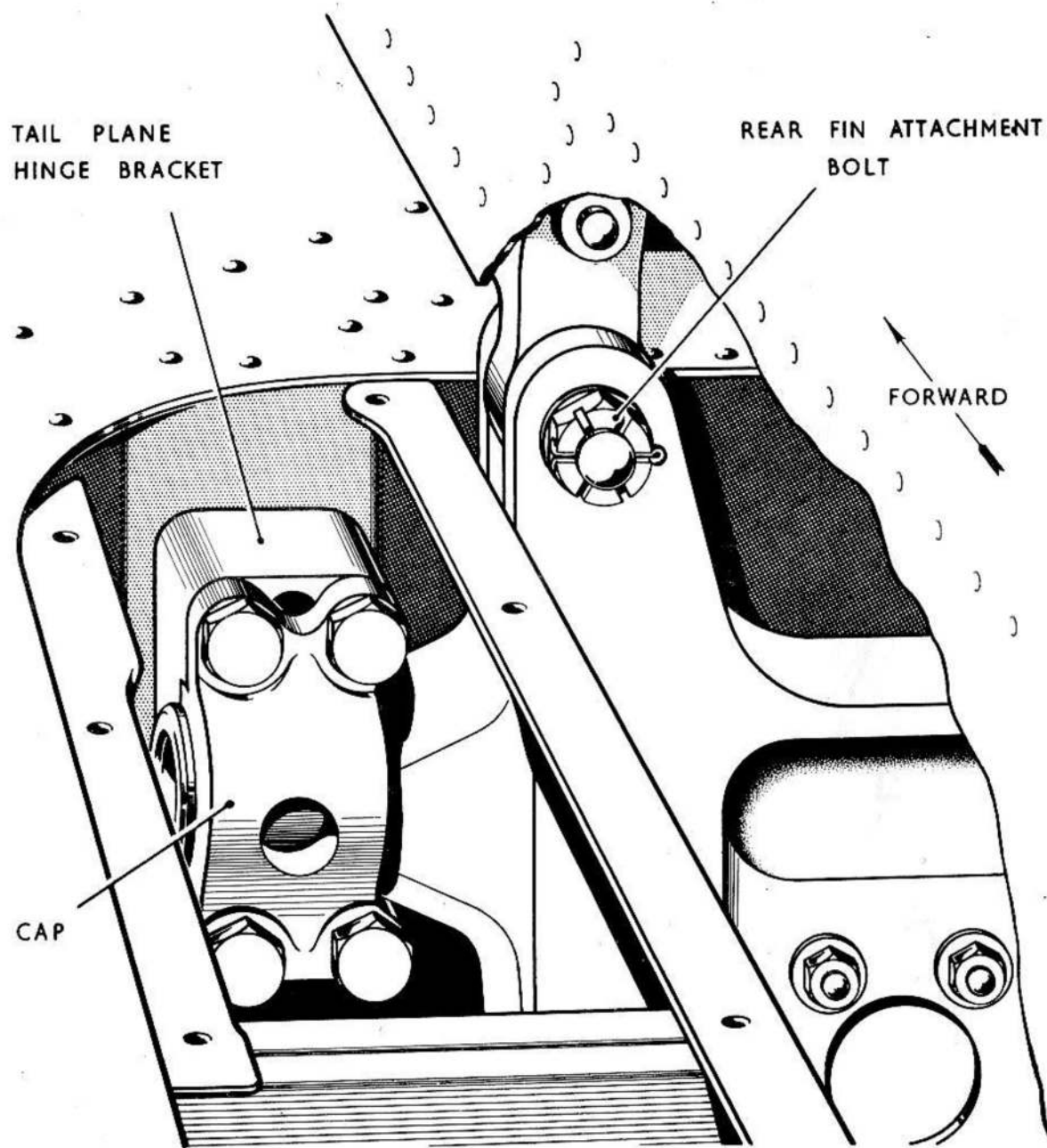

FIG. 6. REAR FIN ATTACHMENT AND TAIL PLANE HINGE BRACKET AND CAP

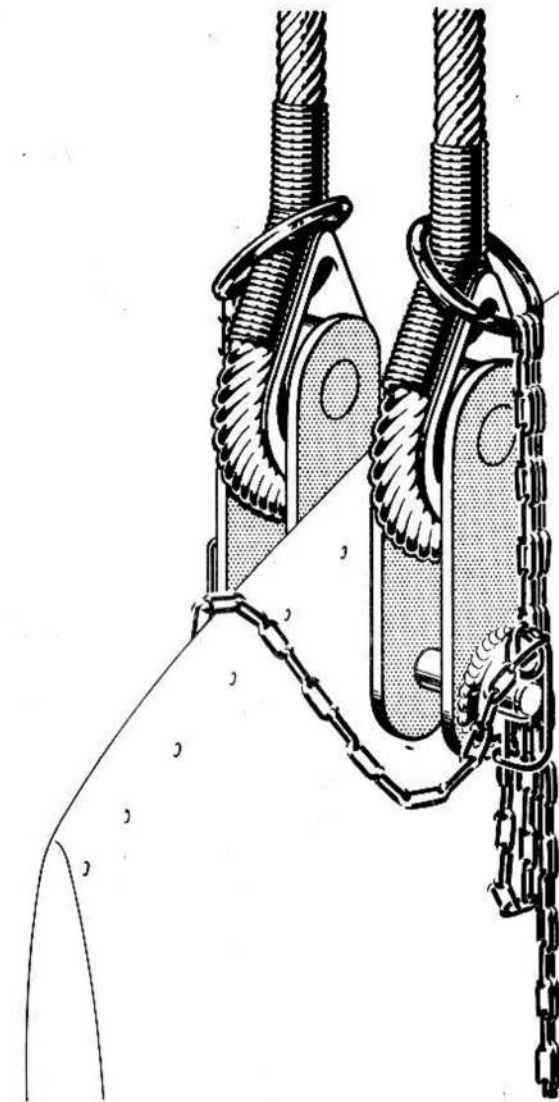

FIG. 4. ATTACHMENT OF RUDDER SLING

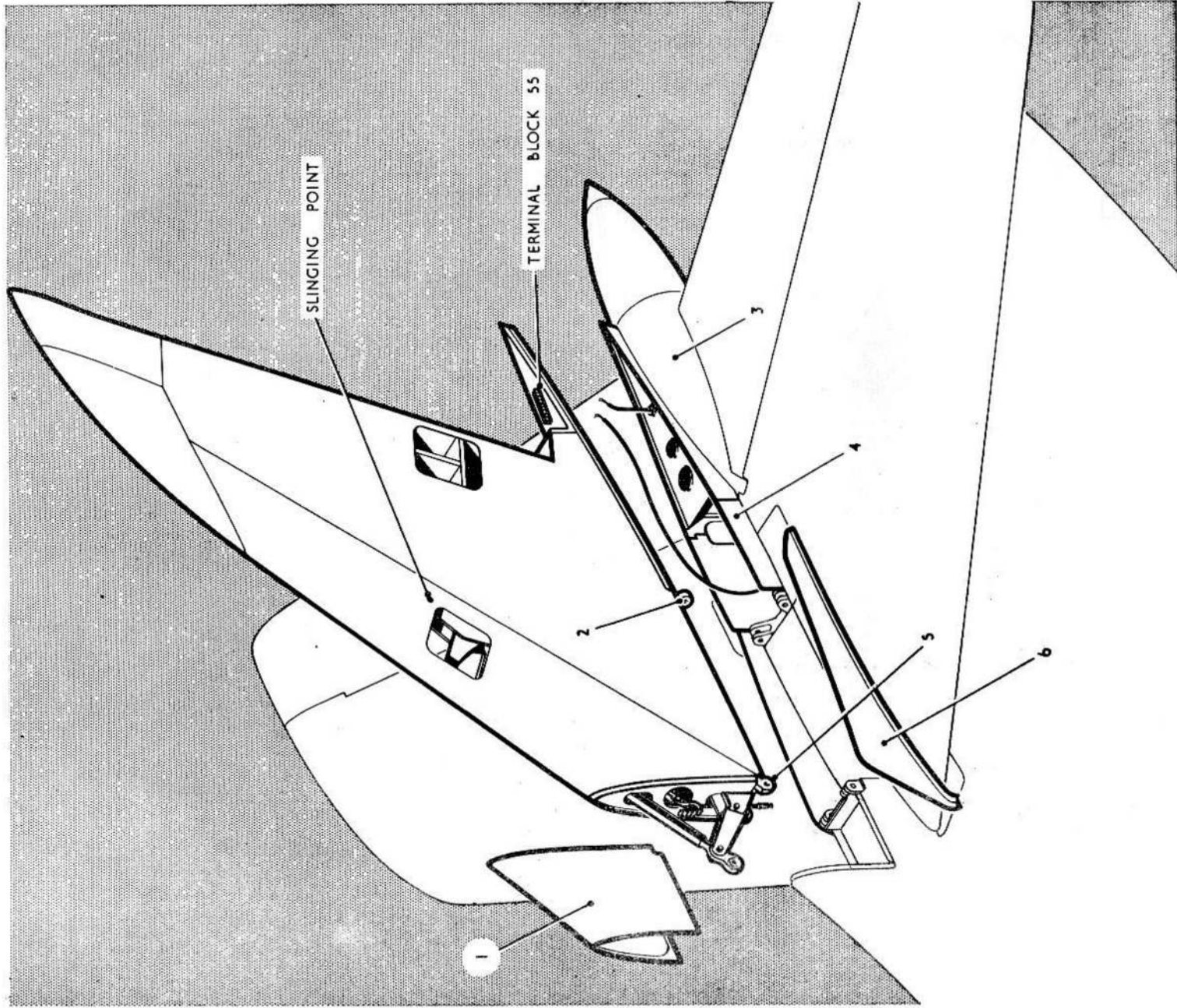

FIG. 5. REMOVAL OF FIN

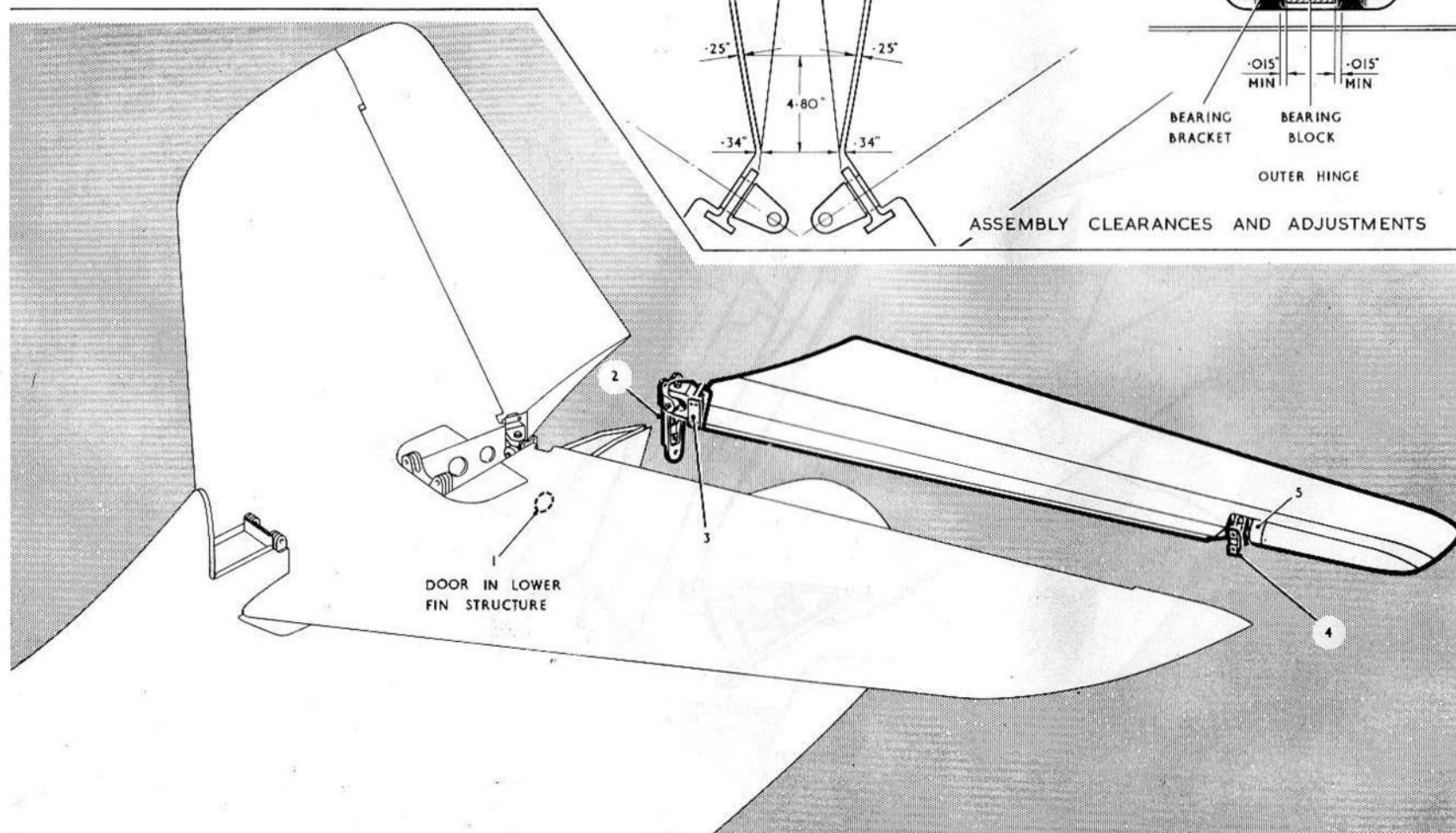
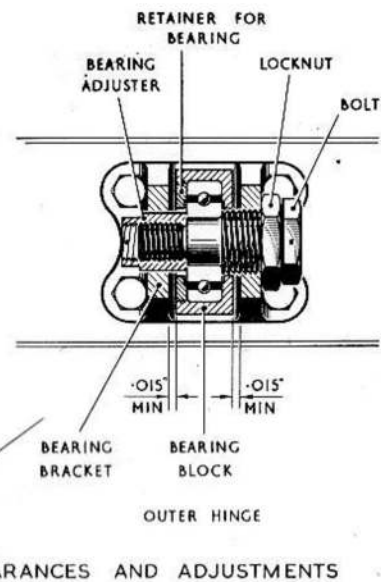
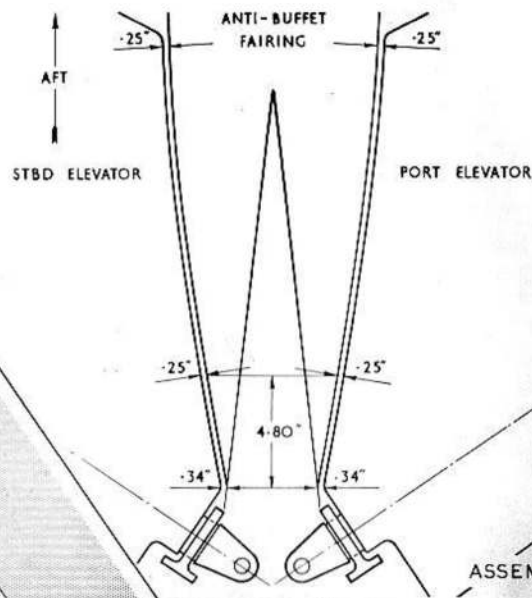
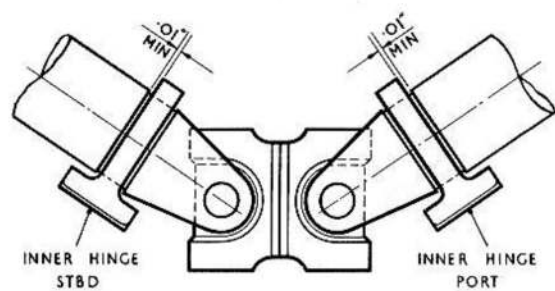

FIG. 8. REMOVAL OF ELEVATOR

Remove the anti buffet fairing (3) and access panels (4) fig.5.

Remove the access doors (1) to the elevator control lever port and starboard, and disconnect the flying controls (detail fig.9).

Remove the four bolts item 1, fig.9 from the elevator control split lever (2) (detail fig.9) connecting the port and starboard elevators.

Note...

The tail plane must be in the fully negative position to allow the removal of the bottom bolt on the split lever.

Remove the four bolts attaching the inner hinge bearing block (3) (detail fig.9) on the port elevator to the tail plane and remove the elevator with the inner and outer hinge bearing blocks attached. There is no provision for slinging the elevators.

ASSEMBLY OF ELEVATORS

The assembly of an existing elevator is the reversal of the removal procedure, but when fitting a replacement elevator the following points must be noted:-

When offering up the elevator the bolts attaching the bearing blocks of the inner and outer hinges should be fitted, but not fully tightened until the split lever has been assembled and bolted up tight.

It will be necessary to adjust the outer locating hinge of the replacement elevator to comply with the requirements given in fig.8. This adjustment is

accomplished by screwing the hinge bolt of the outer hinge assembly in or out of the bearing bracket as required. After adjustment the adjuster and hinge bolt must be locked to the bearing bracket with 18 s.w.g. nickel-alloy wire to Spec.D.T.D.268.

It is possible to adjust the outer hinge without removing the access door if the special spanners Pt. No.F.199406 and F.199407 are used through the gap between the hinge and access door.

After fitment of the elevator, check, with the tail plane at zero incidence, that the minimum gaps as quoted on fig.8 are obtained.

REMOVAL OF TAIL PLANE (KEY TO FIG.10)

Remove the rudder (fig.2).

Remove the fin (fig.5).

Remove the elevator (fig.8).

Remove the bottom tail plane fairing (3), port and starboard.

Remove the plug (fig.11) and attach the tail plane sling (fig.12).

Remove the pin from the Desynn transmitter connecting rod (detail fig.13).

Remove the bolt attaching the jack lever (4) (detail fig.13) on the tail plane to the actuator in the lower fin structure.

RESTRICTED

Remove the access panels (1) port and starboard on the top surface and the access panels port and starboard on the under surface of the tail plane.

Take-off the four bolts at the hinge bracket and cap (fig.6), port, and remove the cap, push the tail plane forward as far as possible, turn the hinge bracket in an anti-clockwise direction looking

forward and remove. Repeat for the starboard bracket - except that the bracket is turned in a clockwise direction - and lift off the tail plane.

Note...

On re-assembly of the tail plane the pivots (2) must be smeared with grease XG-275 (Stores Ref. 34B/222 or 34B/242).

RESTRICTED

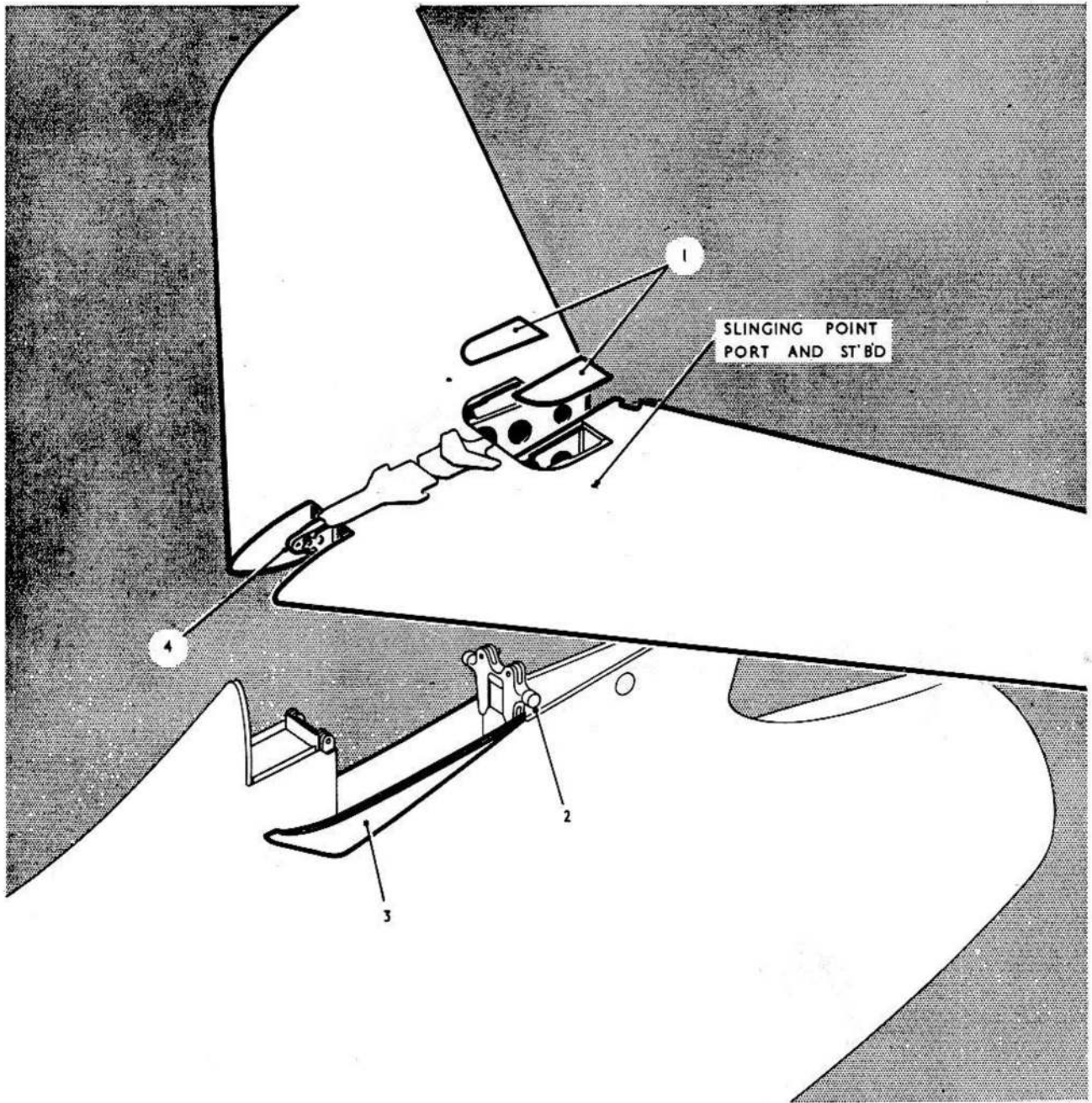

FIG. 10. REMOVAL OF TAIL PLANE

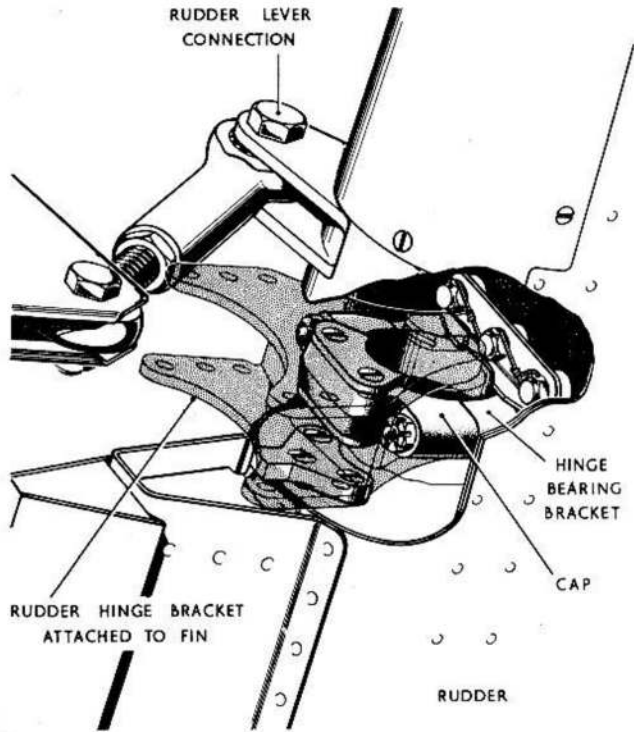

FIG. 3. RUDDER OPERATING LEVER AND BOTTOM HINGE

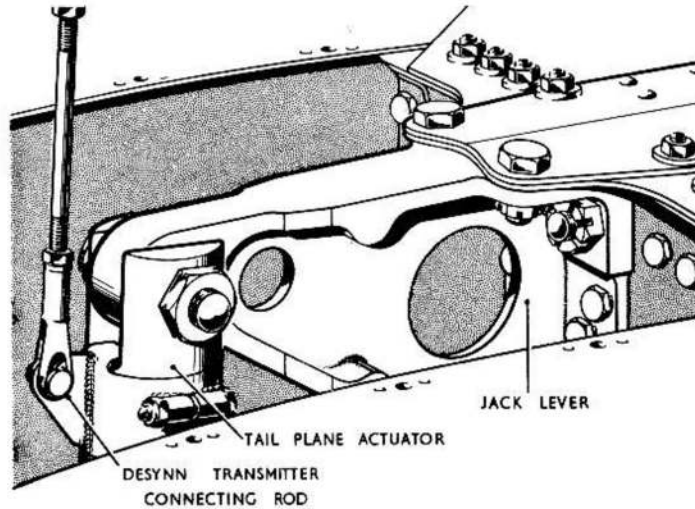

FIG. 13. ATTACHMENT OF JACK LEVER TO TAIL PLANE ACTUATOR

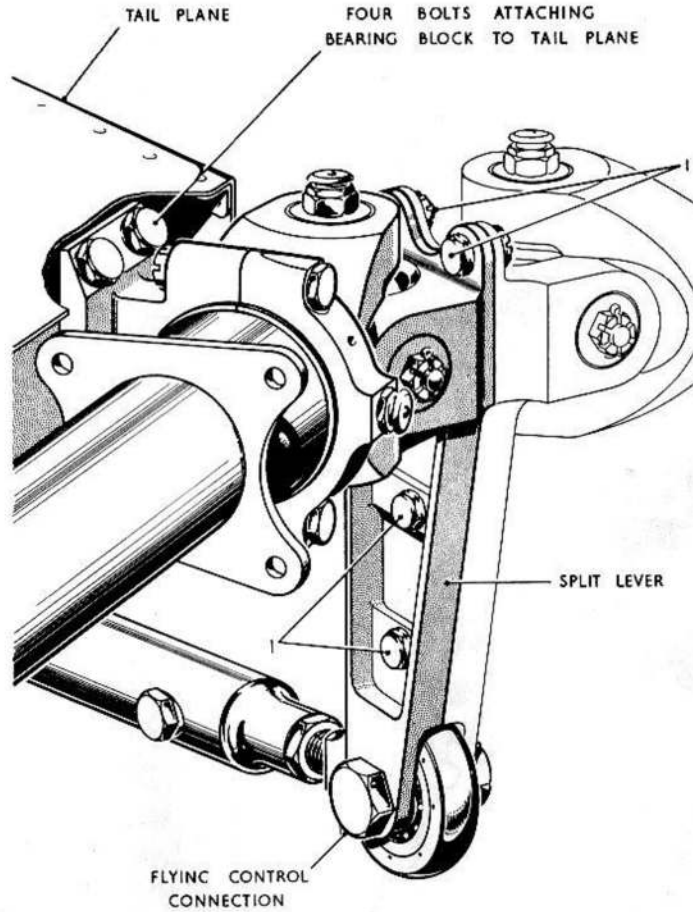

FIG. 9. SPLIT LEVER CONNECTING PORT & STAR'BD ELEVATORS & INNER HINGE BEARING



FIG. 11. PLUG FOR TAIL PLANE SLINGING HOLE



FIG. 12. ATTACHMENT OF TAIL PLANE SLING

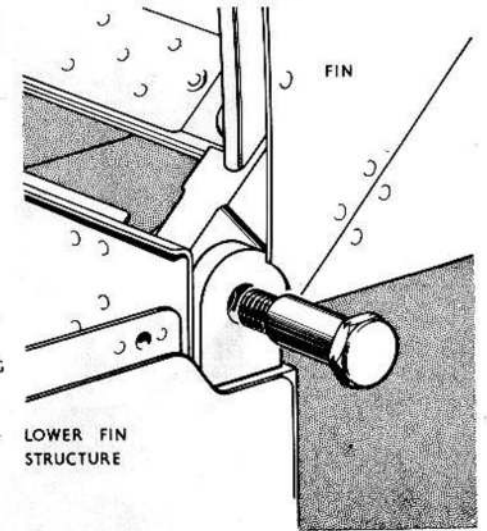
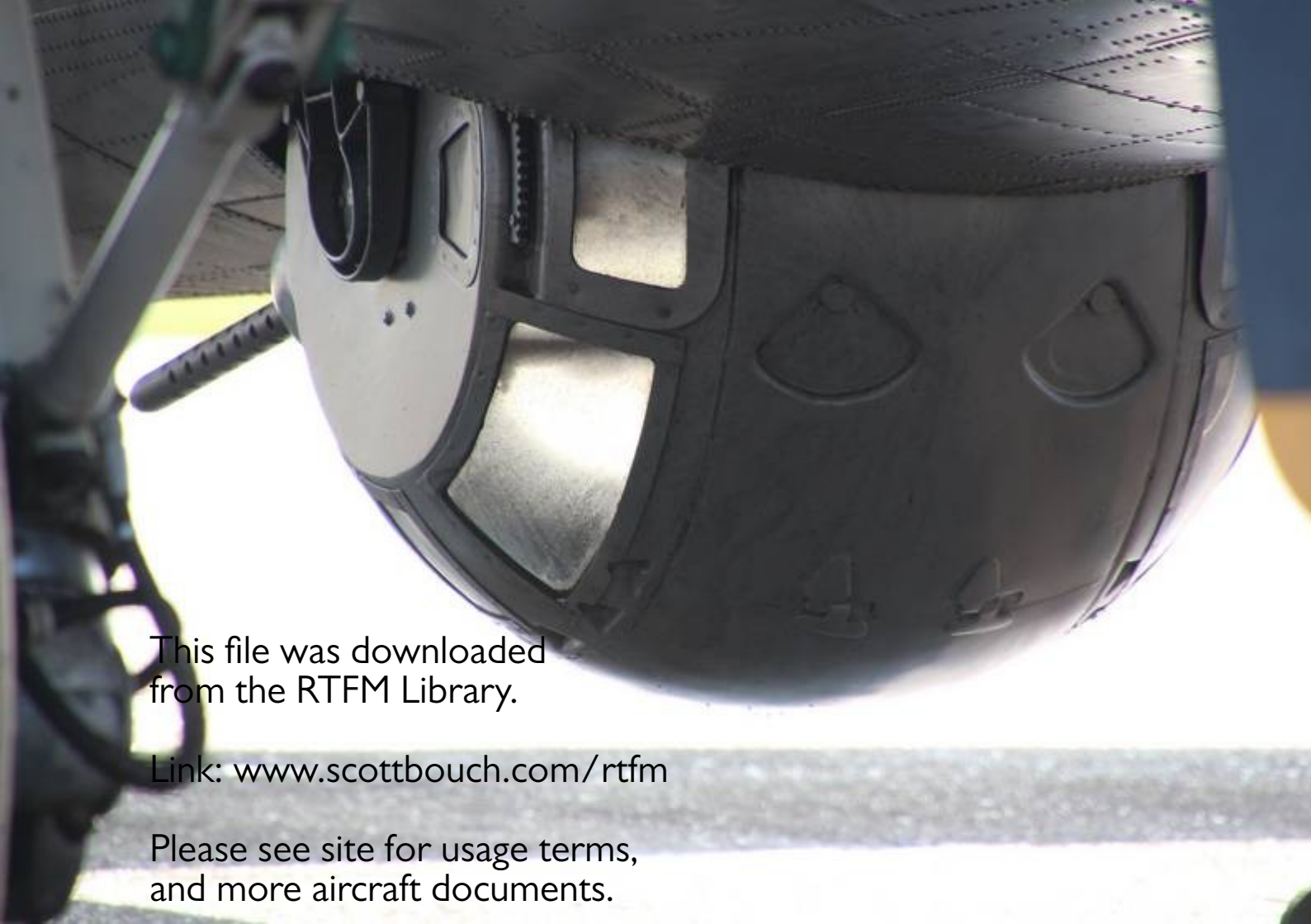

FIG. 7. FIN ATTACHMENT — FRONT



This file was downloaded
from the RTFM Library.

Link: www.scottbouch.com/rtfm

Please see site for usage terms,
and more aircraft documents.