

CHAPTER 5

ALIGHTING GEAR

LIST OF CONTENTS

	<u>Para.</u>		<u>Para.</u>
DESCRIPTION			
Introduction . . . . .	1		
MAIN UNDERCARRIAGE			
	<u>Para.</u>		<u>Para.</u>
General . . . . .	3	Main wheel door sequencing .. . . .	8
Shock-absorber strut anchorage . . . . .	4	Operation	
Jack attachments . . . . .	5	Raising . . . . .	9
Locking . . . . .	6	Lowering . . . . .	10
Doors and operating mechanism .. . . .	7	Undercarriage compression switch . . . . .	11
NOSE UNDERCARRIAGE			
General . . . . .	12	Doors and operating mechanism .. . . .	16
Shock absorber strut anchorage . . . . .	13	Operation	
Jack attachment . . . . .	14	Raising . . . . .	17
Locking . . . . .	15	Lowering . . . . .	18
SERVICING			
General . . . . .	19	Priming and bleeding . . . . .	22

RESTRICTED

## MAIN UNDERCARRIAGE

<u>Para.</u>	<u>Para.</u>
Retraction of single units .. ...	23
Sequence of operations . ...	24
Adjustment of jack .. ...	25
Checking leg and wheel fairings . ...	26
Adjusting wheel fairing . ...	27
Adjusting leg fairing ...	28
Adjusting fairing flaps . ...	29
Adjusting wheel door jacks .. ...	30
Adjusting wheel door down stops and leg sequence valves . ...	31
Adjusting wheel door and leg fairing locks ..	32
Adjusting undercarriage door sequence valves.	33
Adjusting undercarriage emergency air sequence valves .. ...	34
Checking undercarriage position indicator ...	35
Adjusting micro-switch on undercarriage jack..	36
Micro-switches at wheel door and leg fairing locks ...	37
Undercarriage compression switch . ...	38

## NOSE UNDERCARRIAGE

Adjustment of jack . ...	39	Adjusting front door micro-switches .. ...	46
Checking nose wheel doors ...	40	<b>LUBRICATION</b>	
Adjusting nose wheel rear door .. ...	41	General .. ...	47
Adjusting nose wheel front door . ...	42	<b>MISCELLANEOUS</b>	
Adjusting nose wheel door sequence valve ...	43	Wheel brakes . ...	48
Adjusting micro-switch at down lock . ...	44	Tyre wear ...	49
Adjusting nose wheel up micro-switch ...	45	Shock absorber deflection ...	50

## REMOVAL AND ASSEMBLY

	<u>Para.</u>
General . ...	51

## LIST OF ILLUSTRATIONS

<u>Fig.</u>	<u>Fig.</u>
Main undercarriage .. ...	1
Nose undercarriage ...	2

RESTRICTED

LIST OF ILLUSTRATIONS (Contd.)

	<u>Fig.</u>		<u>Fig.</u>
Wheel fairing attachment . . . . .	3	Nose undercarriage adjustments (2) . . . . .	8
Link for undercarriage fairing and fairing flap.	4	Adjustment of nose wheel door lock mechanism and micro switch . . . . .	8A
Main undercarriage adjustments . . . . .	5	Nose undercarriage adjustments (3) . . . . .	9
Adjustment of main undercarriage fairing locks.	5A	Undercarriage lubrication (1) . . . . .	10
Leg fairing lock spigots . . . . .	6	Undercarriage lubrication (2) . . . . .	11
View showing spigot on wheel door engaged in lock . . . . .	6A	Main undercarriage removal . . . . .	12
Wheel door locks - use of gauge for adjustment.	6B	Nose undercarriage removal . . . . .	13
Nose undercarriage adjustments (1) . . . . .	7	"Main U/C deflection check and re-charging" fig.14. "	
		ASSEMBLY OF BRAKE UNITS (MAXARET TYPE) TO U/C LEG 15.	
		METHOD OF SETTING NOSE WHEEL DOOR SEQUENCE VALVE A.	
		METHOD OF SETTING NOSE WHEEL UP-MICRO, SWITCH B.	

DESCRIPTION

Introduction

1. This chapter describes the alighting gear, the servicing necessary to maintain the installation in an airworthy condition and the recommended procedure for the removal and assembly of the components.

Where no specific instructions are given for the dismantling or assembly of a particular component or its servicing, reference should be made to A.P.1803E or A.P.2337. A description of the hydraulic system, which is provided to operate the components, will be found in Sect.3, Chap.6 of this volume. As the operation of some of the units is initiated electrically, reference should be made to Sect.5, Chap.1 for circuit details.

2. The alighting gear consists of two inwardly retracting main wheel units and a forward retracting nose wheel. Each unit is operated by a hydraulic jack, all three being electrically activated by a selector push-button unit in the cabin. The three wheel units are of the liquid-spring cantilever

type, the nose wheel being fully castoring and self-centring during retraction. When fully extended, the main wheel units are secured in the "down" position by mechanical locks incorporated in the hydraulic jacks; the nose wheel is also locked down mechanically. To enclose the units when in their wheel bays, fairing doors are provided, these being operated by hydraulic jacks which are harmonized with those of the alighting gear by means of sequence valves. Undercarriage position indicator lamps are provided, the lamps being incorporated in a common indicator in the cabin. The main wheels are provided with hydraulically-operated brakes. The operation of the brakes is described in Sect.3, Chap.6 of this volume.

MAIN UNDERCARRIAGE (FIG.1)

General

3. Each main wheel unit consists of a telescopic leg which incorporates a liquid-spring shock-absorber assembly and a cantilever axle to support the wheel. Basically, the unit consists of two main parts, an

upper cylinder and a lower cylinder which telescopes into the upper. The upper end of the upper cylinder is solid and is machined to form lugs which accommodate the pintle by which the unit is attached to the aircraft. Other lugs on the unit form attachment points for the torque links, fairing doors, hydraulic jack piston rod and picketing shackles. The unit is fully described in A.P.1803E, Vol.1.

#### Shock-absorber strut anchorage

4. Each main wheel shock-absorber strut is anchored by its pintle to two large bearings contained in structure attached to the undercarriage girder and main spar of the wing, the units swinging inwards on retraction.

#### Jack attachments

5. The combined retracting jack and side stay is mounted inboard of the leg unit in a swivel bearing which is attached to structure contained in the undercarriage girder. The eye-end of the jack piston is attached to a lug on the upper cylinder of the leg unit.

#### Locking

6. The main undercarriage legs are locked down when in the extended position by internal mechanical locks incorporated in the hydraulic jacks. When fully retracted, they are locked up by the fairing doors.

#### Doors and operating mechanism

7. Each main wheel unit is provided with a fairing door which is hinged to the fuselage at the bottom of the stub wing and swings downwards to open. These

doors only partially seal the wheel bay apertures. Fairings, two for each leg and one for each wheel, being attached to the leg units to complete the seal. As in the case of the leg units, the fairing doors are operated hydraulically, each being provided with its own hydraulic jack. Sequence valves ensure that the doors open and close in their proper functional order in relation to the operation of the leg units. Each door is provided with two locks, these being attached to the wing structure and the lock spigots attached to the doors. A lock spigot on the leg fairing also engages with a lock on the wing structure. For a description of the electrical indication system and wiring diagrams, reference should be made to Sect.5, Chap.1 of this volume.

#### Main wheel door sequencing

8. Each main wheel door is controlled by its own sequence valve fitted to a bracket attached to structure in its respective wheel bay in the wing. The valves are operated by the main undercarriage leg contacting a lever assembly when fully retracted so that the wheel doors operate in their proper functional sequence in relation to the leg units.

#### Operation

##### Raising

9. When undercarriage 'UP' is selected, hydraulic power is applied via a solenoid-operated valve to the main wheel jacks and the units commence to retract. The final portion of the leg travel operates the sequence valves which open to allow hydraulic fluid to pass to the wheel door jacks, which close the doors. The spigots on the doors engage with the mechanical locks on the main structure.

## Lowering

10. When undercarriage DOWN is selected, fluid is directed through the two shuttle valves to the anchored ends of the main wheel fairing door jacks, the nose wheel jack and the nose wheel fairing door jacks. These jacks then commence to extend, the initial movement of the main wheel fairing door jacks opening the two inboard fairing door locks (port and starboard). Subsequent extension of the door also operates the leg fairing locks. When these jacks are fully extended the undercarriage DOWN sequence valves open, permitting fluid to flow to the anchored ends of the main undercarriage jacks and at the same time operates a sequence valve which opens the main undercarriage up line to permit the main wheel jacks to extend and lower the wheels. The flow of fluid from the wheel unit jacks is impeded by one way restrictors in the pipe lines, thus preventing the units from extending too rapidly. An internal mechanical lock in each of the main wheel unit jacks secures the legs in the extended position.

## Undercarriage compression switch

11. Each main undercarriage leg is fitted with a micro switch, mounted on a serrated bracket attached to the leg. These switches oppose a plunger assembly housed in the lower end of the bracket. On full compression of the leg as occurs when the aircraft is on the ground, the switches operate to prevent inadvertent retraction of the undercarriage and operation of the armament installations.

## NOSE UNDERCARRIAGE (Fig.2)

### General

12. The nose undercarriage is a fully castoring and

self centring telescopic unit, which is provided with a centring mechanism and a 'DOWN' lock. It retracts into the nose of the aircraft. Basically, the unit consists of three main parts, an upper cylinder, a pivot bracket assembly which swivels in the bore of the upper cylinder and a lower cylinder which slides into the bore of the pivot bracket swivel tube. The lower cylinder accommodates the ram piston and shock-absorber assembly. The tube of the pivot bracket assembly is located end-wise in the top of the bore of the upper cylinder and is free to rotate. The lower end of the pivot bracket tube is extended forwards to form two lugs which are bored to accommodate the upper pivot pin of the wheel fork assembly. The wheel is mounted on an axle located in the wheel fork, the fork being secured by bolts which are themselves secured by locking plates. The unit is described in A.P.1803E, Vol.1, Sect.6.

### Shock-absorber strut anchorage

13. A boss formed on the rear of the upper cylinder of the nose wheel unit is bored to accommodate the pivot pin by which the unit is hinged to bearings in frame 8 of the aircraft.

### Jack attachment

14. The nose wheel operating jack is pivoted in bearings contained in diaphragms between frames 10 and 11, the piston rod being attached to a jack retracting arm fitted to the upper end of the leg unit above the pivot bearing boss. Retraction of the jack piston rod swings the leg forwards and upwards into the wheel bay in the nose of the aircraft.

### Locking

15. The leg unit is provided with a spring-loaded plunger at its upper end. On the final movement of

the leg to the down position, the plunger rides up and over a fixture in the aircraft structure to spring into the locking position behind it, leaving the pivot bracket free to rotate. When undercarriage 'UP' is selected, the initial movement of the jack piston rod exerts a pull on the jack retracting arm on the leg. This arm has a limited movement which actuates a lever to depress the plunger, thus releasing the lock so that the leg can be swung up. There is no lock for the up position, the leg unit being secured by the fairing doors.

#### Doors and operating mechanism

16. The two fairing doors provided to enclose the nose wheel and secure it on retraction, are mounted fore and aft of the wheel well in the nose of the aircraft. The front door is hinged to structure in the region of frame 3 and the rear one at frame 8. The rear door is also coupled to the leg unit by means of tie rods and consequently is raised into position by the leg on retraction. A lip on the forward edge of the rear door forms a landing for the rear edge of the front door, which secures the rear door in the closed position. The front door is operated hydraulically, the jack being controlled by a sequence valve which ensures the closing of the door in its proper functional order in relation to the operation of the nose wheel unit. The front door is provided with two locks on the rear edge with a micro-switch adjacent to each, which with further switches on frame 7 and frame 8 operate the indicator lamps in the cabin. The operation of these switches and others in the alighting gear circuit is described in Sect.5, Chap.1.

#### Operation

##### Raising

17. When undercarriage 'UP' is selected, hydraulic

power is supplied to the nose wheel jack, the flow of fluid to the door jack being delayed by the sequence valve until the leg unit is fully retracted. The nose wheel jack retracts and the wheel unit with the rear door is drawn up, followed by the closing of the front door on the operation of the sequence valve.

##### Lowering

18. When undercarriage 'DOWN' is selected, hydraulic power is applied to both the nose wheel jack and door jack simultaneously. The nose wheel door jack extends first, the initial movement of the jack piston rod operating the release mechanism of the door locks via a lever assembly, the final movement allowing the nose wheel door jack to extend followed by extension of the nose wheel jack to lower the wheel unit to the locked down position. For a description of the emergency operation of the undercarriage, reference should be made to Sect.3, Chap.6 of this volume.

### SERVICING

#### General

19. Before attempting to adjust the alighting gear, the aircraft must be trestled with the wheels clear of the ground as shown in Sect.2, Chap.4, fig.4. It is essential that the hydraulic adjustments described be made with the system at the blow-off pressure of the hand pump (Leading Particulars) and that unless otherwise stated, each operation should be made on one unit at a time. It must not be assumed that any pair of components require the same amount of adjustment, or that because one part is

"NOTE...

Before lowering the aircraft off the jacks, the procedure given in fig.14 must be carried out. This is important.

the units, it is essential to ensure that the area is free from obstructions and that no personnel are working on or in the vicinity of that part of the aircraft affected.

21. If it is found necessary to remove any part of the system, pipe ends and unions must be immediately blanked off to exclude the entry of foreign matter. Before replacement, parts should be given a thorough examination to ensure absolute cleanliness.

#### Priming and bleeding

22. Whenever a component has been removed or a pipe line disconnected for any reason, the system must be primed and bled after replacement or re-connection to exclude any air which is trapped in the system. The procedure for priming and bleeding is given in Sect.3, Chap.6 of this volume.

#### MAIN UNDERCARRIAGE

##### Retraction of single units

23. It is possible to retract one unit separately by fitting the undercarriage safety stop to the other unit. If it is required to isolate the nose wheel unit also, the nose wheel stop should be fitted. The method of fitting the safety stops is given in Sect.2, Chap.1 of this volume.

##### Sequence of operations

24. If the adjustment of the undercarriage is being carried out as a complete operation as, for example, after the replacement of a complete unit, the work described in para.25 to 37 should be carried out in that sequence as this constitutes the procedure adopted by the manufacturers for the initial adjustment of the undercarriage

##### Adjustment of jack

25. It is essential that the extended length of the jack is such that when the undercarriage leg is pumped right down, the axle of the wheel is at an angle of 0 deg. 26 min. (i.e. tops of wheels inclined inwards). The jack should be adjusted as follows:-

- (1) Dissipate the hydraulic pressure in the undercarriage down line.
- (2) Unlock and slacken the lock-nut on the jack piston rod to the full extent.
- (3) Remove the pin securing the locking bush and withdraw the locking bush from engagement with the piston rod.
- (4) Hold the spanner grip at the end of the piston rod with a C spanner and turn the rod in the required direction, until the correct length is obtained.
- (5) When adjustment is complete, return the locking bush to engage with the nearest slots in the piston rod, refit the securing pin and tighten the locknut, holding the piston rod to prevent it from turning. Then, with pressure applied to the down line, check the angular position of the wheel axle.
- (6) Raise the leg fully and check that the gap between the rim of the wheel and structure is not less than 0.20 in. and that the gap between the tyre and wheel fairing is not less than 0.25 in. (port and starboard). The angle of the axle initially obtained may have to be altered to achieve this.

- (7) When adjustment is satisfactory, lock the locknut to the locking bush with stainless steel wire DTD.189 (Ref. No. 30A/2514).

#### Checking leg and wheel fairings

26. After adjusting the jack, as in para.25, raise the undercarriage gently and check that the fairings are flush with the undersurface of the wing and seating correctly on their landings with the leg fully retracted. If this condition is not obtained, the fairings must be adjusted as described in para.27 to 29.

#### Adjusting wheel fairing (fig.3)

27. If the wheel fairing is not seating correctly on its landing proceed as follows:-

- (1) Lower the leg and slacken off the four bolts (5) securing the fairing to its attachment brackets until the serrated plates (4) and washers (3) are just loose enough to allow the fairing to be moved about the fixing plates by hand, but not so slack as to allow it to move about of its own accord.
- (2) Slacken off the clamping nuts (2) passing through the ends of the attachment brackets (6).
- (3) The fairing may now be moved by hand about its attachments against the friction of the serrated plates, washers and fixing plates, or moved away from, or nearer to the leg by rotating the adjusting sleeves (1) which pass through the attachment brackets.
- (4) Obtain the correct fitting by trial and error, bearing in mind the relationship of the wheel fairing to the wheel door. Take care not to damage the fairing by raising

the leg too quickly.

- (5) When adjustment is complete, tighten the clamping nuts (2) and attachment bolts (5) taking care not to turn the adjusting sleeves. Lock the attachment bolts and adjusting sleeves with stainless steel locking wire, DTD.189 (Ref. No.30A/2514).

#### Adjusting leg fairing (fig.1, 4 and 6)

28. If after the check described in para.26, it is found that the leg fairing needs adjustment, proceed as follows:-

- (1) Lower the leg, slacken off the lock-nuts (fig.4, item 1) on the operating links and rotate the rods in the required direction.
- (2) Slowly raise the leg and check to see if the fairing is now seating correctly. If not, lower the leg again and adjust the links until the desired result is obtained.
- (3) If the fairing is seating correctly, but is not locked, or is prevented from seating correctly by fouling the lock mounted on the interspar rib D, the spigot (fig.6) on the leg fairing must be adjusted by slackening the attachment screws and moving the spigot on the serrations to obtain the condition of correct engagement of the spigot in the lock and seating of the fairing.
- (4) When adjustment is complete and the fairing is correctly locked, lower the leg once more and tighten the lock-nuts.

#### Adjusting fairing flaps (fig.1 and 4)

29. If after the check described in para.26 it is found that the fairing flap at the top of the leg

fairing is not seating correctly, proceed as follows:-

- (1) Lower the leg, slacken off the lock-nuts (fig.4, item 1) on the operating link and rotate the rod in the required direction.
- (2) Slowly raise the leg and check to see if the fairing is now seating correctly. If not, lower the leg again and adjust the link until the desired result is obtained.
- (3) When adjustment is complete, lower the leg once more and tighten the lock-nuts.

Adjusting wheel door jacks (fig.5)

30. Each wheel door should be adjusted so that it locks up flush with the undersurface of the aircraft just as the jack reaches the limit of its travel. If these conditions are not obtained, adjust as follows:-

- (1) Fit the safety stop to the undercarriage retracting jack, thus preventing the leg from retracting, to allow the operation of the wheel door jack and locks to be observed.
- (2) Depress the sequence valve, mounted on interspar rib E, by hand and raise the door hydraulically, and if it locks "UP" but stands proud of its landings, adjust the locking pins by altering the disposition of the shims (1) until the correct fitting is obtained as described in para.31, sub-para.(1).
- (3) If on the other hand, the jack reaches the limit of its travel before the door closes and locks up, shorten the jack piston rod by

Unlocking and slackening the lock-nut (2) on the jack piston and turning the jack ram, using the spanner grip provided, in the required direction until the correct adjustment is obtained. Finally open the door, tighten and lock the lock-nut on the jack piston rod.

Adjusting wheel door down stops and leg sequence valves (fig.5)

31. Each wheel door is provided with a down stop, consisting of a rod, the lower end being attached to the wheel door and the upper end carrying a striker. The rod passes through a trunnion, attached to a bracket mounted to the fuselage skin just aft of the front spar, which forms the stop for the striker. The striker also actuates the operating lever of the sequence valve controlling the undercarriage leg operation, when the door is fully open. The length of the stop rod must be adjusted so that the striker is about to make contact with the trunnion (see sub para.1 for gap) and is also depressing the sequence valve operating lever the required amount when the wheel door is fully open, the jack is at the limit of its travel, and the lever to which the upper end of the jack is anchored, is held hard against the top stop above the detent pin. To adjust proceed as follows:-

- (1) Check that there is a gap of 0.010 in. to 0.050 in. between the striker (7) (detail A) and the trunnion (6) when the wheel door is fully opened and the jack at the limit of its travel with full hydraulic pressure on the door held outboard by hand. If not, disengage the stop rod (5) from its attachment on the door and slacken the lock-nut above the fork-end. Adjust the rod by screwing the fork-end in half turns at a time until the

correct length is obtained. When correct tighten the locknut and reconnect the rod to the door.

- (2) If the striker makes contact with the trunnion before the wheel door jack reaches the limit of its travel, the stop rod (5) must be lengthened in a similar manner to that described in sub-para.(1) until the correct length is obtained.
- (3) When the stop rod has been adjusted, measure the distance between the head of the lever (4), in contact with the plunger of the sequence valve (3) and the body of the valve.
- (4) Raise the wheel door until the striker is free from the sequence valve operating lever (4) and measure the distance between the end of the valve plunger and the valve body. This distance must now be 0.09 in. to 0.12 in. greater than that obtained in sub-para.(3), (with the free movement of the valve plunger taken up) thus ensuring that the plunger is depressed the required amount to fully open the valve. If this measurement is not obtained adjust the lever adjusting screw (8) as necessary by slackening the lock-nut and adjusting the screw in or out as required. When the correct setting is obtained, tighten the lock-nut and wire lock.

Adjusting wheel door and leg fairing locks  
(fig.5, 5A, 6A and 6B).

~~... leg fairing locks are~~  
"32. The wheel door and leg fairing locks are operated as described in para.10 of this chapter. The procedure for adjustment is as follows:-"  
~~Universal~~  
to the lock operating levers by adjustable control

~~rods and a Teleflex cable. The adjustment of the lock is as follows:-~~

#### Inboard locks

#### NOTE...

Before commencing adjustment, ensure that the connecting rods are assembled with the R.H. threaded fork-ends at the locks.

- (1) Check the backlash in the wheel door operating mechanism. If it is found that the backlash, as felt at the rear lever on the universal shaft, when the lever at the upper end of the wheel door jack is hard against the top stop exceeds 0.20 in., the universal shaft is to be rejected (See NOTE in fig.5 for backlash check). If the existing shaft is acceptable or if a new shaft has been fitted, proceed with the following operations:-
- (2) Fit the undercarriage safety stops (Sect.2, Chap.1) and jack the aircraft with the wheels clear of the ground (Sect.2, Chap.4).
- (3) Fully retract the wheel door by depressing the plunger of the sequence valve in roof of wheel well and operating the hand pump with undercarriage up selected. Check that there is a gap of at least .005" between the underside of the wheel door spigot and the hooks of the wheel door locks. If not, any one of the alternative shims (F.211330, F.211331, F.211332 FWD and F.211333, F.211334, F.211335 AFT) may be used to give this condition (fig.6A). Shims to be used in conjunction with those called for on assembly of wheel door.
- (4) The jack anchorage lever will now be in the lower position. Select undercarriage down,

operate hand pump and lightly trap the thick end of the gauge (Part No.A.210992 Port - Part No.A.210993 Starboard) between top face of lever and stop block. (As shown in fig. 6B, detail 'A'). Disconnect both lock operating rods from the levers on the universal shaft, pull the rear lever outboard to take up any backlash, adjust the length of the rear control rod until it can be re-connected to lever on the universal shaft, with backlash still taken up. Release the front lock by moving the lock lever inboard and retain in this position while shortening the rear control rod further until the rear lock just opens. Relock the control rod and its attachments.

- (5) Take wheel door right down, select undercarriage up, remove gauge and pump door up. When the spigots have re-engaged in the locks, re-connect the front control rod. Select undercarriage down, operate the hand pump and lightly trap the thinner end of the gauge between the lever and the stop block (As shown in detail 'B'). Adjust the front control rod until the front lock just opens, relock the rod and its attachments.
- (6A) Select undercarriage up, remove the gauge and pump the door up until fully retracted. Check that the locks are fully engaged by passing 1/8" dia. test rod through hole 'X' and 'Y' (fig.5A) and that the gaps at the lock levers are as indicated.
- (6B) Pump the wheel door right down using full hydraulic hand pump pressure to ensure that the internal lock of the undercarriage jacks, which may have disengaged when raising the wheel door, have re-engaged, and the jack anchorage lever returns to the top position.

#### Leg fairing lock

- (7) With the wheel door fully closed, temporarily secure a spring balance (No.3 size 0 - 50 lb.) as shown in fig.5A and tension to 20 - 25 lb. to ensure that the roller is in line with the guide bracket.
- (8) Adjust the Teleflex sliding end to butt against the stop.
- (9) Release the wheel door locks and open the door until extension of the Teleflex is just completed as indicated by the pointer on the spring balance scale. (At this point, the load on the spring balance must be approximately 40 - 50 lb.). With the wheel door temporarily secured in this position, adjust the outboard end of the Teleflex control until the lock is fully operated and the latch is against the stop.

NOTE... The following points are important:-

- (a) All backlash must be taken up during the adjustment of this end of the control. To ensure this, a load of approximately 25 lb. must be applied during the operation of adjustment.
- (b) The spring-loaded plunger of the Emergency Air Release Valve tends to force the latch away from its stop. Therefore, to ensure that the latch is hard against its stop while making the adjustment, either apply a suitable load to the lock lever to overcome the effect of the spring-loaded plunger, or depress the plunger so that it no longer makes contact with the latch.

- (10) Screw the fork end out 2 complete turns (i.e. 0.07 in. approx.). The latch will then be away from the stop and will be correctly set.
- (11) Remove the spring balance and close the wheel door. Check that the leg fairing lock is fully closed.
- (12) After all adjustments are complete, carry out function checks of the wheel doors, checking indicator lights and ensuring that micro switches are set as detailed in para.37.
- (13) Pump the wheel door right down, using full hydraulic handpump pressure to ensure that the internal locks of the undercarriage jacks, which may have disengaged when raising the wheel door, have re-engaged, and that the wheel door jack lever returns to the top position.
- (14) Adjust micro-switches as described in para. 36 and 37.
- (15) Remove safety locks. Carry out full undercarriage retraction tests with hydraulic rig coupled up.

Adjusting undercarriage door sequence valves (fig.1)

NOTE...

On a complete aircraft this operation requires the removal of the leg fairing for access. If the undercarriage is being replaced this operation should be performed before the leg fairing is attached to the leg.

33. Each wheel door is controlled by a separate sequence valve mounted on interspar rib E in the wheel bays. These valves are operated by the undercarriage legs when in the fully retracted position. To ensure

that the valves operate correctly, each should be adjusted as follows:-

- (1) Remove the undercarriage safety stop fitted in para.30 (1).
- (2) Disengage the wheel door jack from its attachment on the door.
- (3) Measure the projection of the plunger on the sequence valve from the body of the valve.
- (4) Raise the leg and when fully up, again measure the projection of the plunger on the sequence valve. This dimension should be 0.10 in. to 0.14 in. less than that obtained in sub para. (3) above, to ensure that the valve is fully opened.
- (5) If this condition is not obtained, the special bolt passing through the sequence valve operating lever should be unlocked and screwed in or out until the dimension given in sub para.4 is obtained. When adjustment is complete, lower the leg and tighten the locknut on the special bolt.
- (6) When all the adjustments are complete, re-connect the wheel door jack to its attachment on the door and refit the leg fairing. Finally raise the complete undercarriage to check that the sequence valve is operating satisfactorily.
- (7) Check that the wheel door closes properly and locks up flush with the undersurface, and does not foul the wheel fairing. If this occurs, check the position of the wheel fairing to ensure that excessive clearance has not been left at the top edges and adjust accordingly.

- (8) Raise the undercarriage and check that the red lights are extinguished, indicating that all wheel door and fairing locks are operating correctly.

#### Adjusting undercarriage emergency air sequence valves

34. The emergency air sequence valves are mounted on brackets fitted to structure just aft of the front spar in the wheel bay, port and starboard. They are operated from the leg fairing locks via spring loaded plungers. With the locks in the fully closed position, the air pipes disconnected from the valves, and operating cables disconnected from the locks, the position of the sequence valves should be adjusted by varying the position of the washers and shims on either side of the brackets until the gaps between the respective spring-loaded plungers and the face of the sequence valve gland nut are within the limits of 0.16 in. and 0.17 in. After adjustment, attach an air line to the horizontal connection on each sequence valve in turn and release the appropriate leg fairing lock by pressure on the operating lever. Ensure that correct valve operation is obtained, allowing air to pass from the vertical connection. Remove air line, reconnect and lock air pipes to valves. Reconnect and lock operating cables to wheel fairing locks.

#### Checking undercarriage position indicator

35. Whenever adjustments of any kind have been made to the undercarriage, a final check must always be made to ensure that the micro-switches are operating satisfactorily. This test should be made with both undercarriage units and both wheel doors connected up. The procedure is as follows:-

- (1) Lower the undercarriage and check that three green lights show on the undercarriage indicator in the cabin.
- (2) Raise the undercarriage slowly and check that as soon as it starts to retract, the green lights go out and the red lights appear on the indicator.

- (3) Continue to raise the undercarriage and check that as soon as the wheel doors close and lock up, there are no lights showing on the indicator.
- (4) Select undercarriage 'DOWN', but do not operate the handpump (This relieves the hydraulic pressure, thus allowing the undercarriage to be supported by the wheel door and fairing locks). Check that the red lights do not re-appear on the indicator. Also check that neither the wheel doors nor the leg fairings stand proud of the undersurface of the aircraft This is most important.

#### Adjusting micro-switch on undercarriage jack (fig.1)

36. This switch is operated by a lever projecting from inside the jack, the lever being moved by the jack piston. With the main undercarriage jack fully extended under hydraulic pressure, insert a 14G or 0.080 in. feeler between the switch and the operating lever. Adjust the switch by loosening the bolts securing the switch until the serrated plates are free, moving the switch until the plunger is fully depressed. Re-tighten the bolts and remove the feeler.

#### Micro-switches at wheel door and leg fairing locks

37. These micro switches are all adjusted and correctly fitted on initial assembly, thus apart from checking that there is a maximum gap of 0.02 in. between the switch plungers and operating levers when the locks are closed no further adjustment should be necessary, unless the locks are re-adjusted or replaced.

#### Undercarriage compression switch

38. The undercarriage compression switch should be adjusted as follows:-

- (1) With the undercarriage leg in a static

condition (i.e. aircraft on the ground), the gap between the switch plunger and the striker on the leg must be adjusted until it is between 0.010 and 0.015 in.

#### NOSE UNDERCARRIAGE (fig.2)

##### Adjustment of jack (fig.9)

39. It is essential that the extended length of the jack is such that when the nose wheel unit is pumped right down, the 'DOWN' lock plunger in the top of the leg is in full engagement with the 'DOWN' lock (3) in the aircraft structure. To adjust the length of the jack piston rod, proceed as follows:-

- (1) Disengage the jack (6) from its attachment (4) on the nose wheel unit.
- (2) Unlock and slacken off the lock-nut (5) on the eyebolt on the jack piston rod.
- (3) With the nose wheel unit fully engaged with the down lock (3), fully extend the jack and adjust the length of the jack ram by holding the eye-end and turning the ram, using the spanner grip (hydraulic pressure must be dissipated before the ram can be turned) until the eye-end will align with the attachment on the nose wheel unit. Lengthen the ram a further 1/32" (approx.) after this adjustment has been achieved.
- (4) Tighten the lock-nut (5) and relock with stainless steel wire DTD.189 (Ref.No. 30A/2514).
- (5) Retract the jack slightly, unlock the leg and raise it until the jack can be reconnected to the attachment on the leg. Finally raise the leg completely and check that this adjustment has not upset the adjustment of the UP locks on the nose wheel door.

##### Checking nose wheel doors

40. After adjusting the jack, raise the nose wheel unit and check that the nose wheel doors lock up flush with the undersurface of the aircraft when the unit is fully retracted. If they do not lock up in this manner, the door should be adjusted as described in para.41 and 42.

##### NOTE...

With the leg locked up, i.e. front and rear doors seating on their landings, the smallest gap between the rear door reinforcing brackets (Pt. No. 219788-9) and the front door inner skin is to be 0.01 in. to 0.04 in. Shims (Part No.F.210813) are to be used as required. The face of the bracket need not be parallel with the face of the front door. Washers may be removed from the bolts, if necessary, when fitting shims.

##### Adjusting nose wheel rear door (fig.2)

41. If the check described in para.40 shows that the rear door is not seating correctly on its landings, proceed as follows:-

- (1) Lower the leg and slacken off the lock-nuts on the tie-rods connecting the door to the nose wheel unit.
- (2) Adjust the rods as required by rotating them in the required direction with a spanner.
- (3) Raise the leg to ensure that the door is now seating correctly. If not, repeat operation (2) until the desired result is obtained.
- (4) When adjustment is complete, tighten the lock-nuts. Wire-lock all bolts.

##### Adjusting nose wheel front door (fig.7, 8 and 9)

42. If the front door fails to lock up flush with the undersurface of the aircraft, proceed as follows:-

- (1) Lower the nose wheel unit completely.
- (2) Close the door by depressing the sequence valve plunger (item 8, fig.9) and using the hand pump. If it will not lock up or stands proud of its landings, adjust the lock spigots by slackening the attachment bolts and moving the spigots about the serrated plates until the correct fitting is obtained. When adjustment is complete, re-tighten the spigot attachment bolts.

## NOTE...

If difficulty is encountered with the landings at the front of the door, the position of the hinges can be adjusted by removing or inserting shims under the heads of the hinge bolts and hinge (brackets item 6, fig.7). If a new door is fitted, the hinges must be checked for alignment.

- (3) Lower the door and close both door locks by pressing a piece of metal or a suitable tool, not exceeding 5/16" diameter against the wedge in the jaws of the lock.
- (4) Press the bottom of the door, in the centre gently aft and check that both locks open, thus ensuring that the initial movement of the door jack, when connected, will release the locks before attempting to open the door.
- (5) If the above condition is not obtained, adjust as described in para.46.
- (6) Adjust the length of the door operating rods (item 4, fig.7) to a nominal dimension of 10.95 in. between the eye-end centres by slackening the locknut, thus freeing the locking washer from its slots, and then turning the eye-end until the dimension is obtained. When adjustment is satisfactory

reconnect the rods to the levers (item 5, fig.7) on the door.

- (7) Disconnect the door operating jack (item 1, fig.7) from the lever (item 3) and fully retract the jack. Adjust the jack ram so that the overall dimension between pin centres is exactly 10.20 in. Re-connect the jack to the lever.
- (8) Check that the door locks are open, if not press the bottom of the door as in sub-para. (4) above to open the locks and then retract the door hydraulically.

## NOTE...

It is necessary to depress the sequence valve (item 2, fig.9) in the nose wheel bay, before the door will respond.

- (9) Check that the door locks up just before the jack reaches the limit of its travel.
- (10) If this condition is not obtained adjust the rods (item 4, fig.7) until the required condition is satisfied. When adjustment is satisfactorily completed, lock the lock nuts with 22 s.w.g. stainless steel locking wire to Specification DTD.189 or 161.
- (11) Check for correct operation of the micro-switches and sequence valve (para.43 to 46).

Adjusting nose wheel door sequence valve (fig.9 and 9A)

43. The nose wheel front door is controlled by a sequence valve mounted on frame 7 in the nose wheel bay. The valve is operated by the nose wheel leg when in the fully retracted position and to ensure that it is operated correctly, it must be adjusted as described in fig.9A. When adjustment is satisfactorily

completed, raise the nose wheel unit to ensure that the valve is functioning correctly and check that the door commences to close when the leg is fully retracted.

Adjusting micro-switch at down lock (fig.2 and 9)

44. This switch (fig.9, item 7) should be adjusted so that its plunger is depressed the required amount when the leg is locked down. To adjust, loosen the bolts securing the switch to the aircraft structure and move the switch up or down to give the following conditions:-

With the leg locked down and the leg locking plunger in contact with the switch plunger it should be possible to depress the latter by hand for a further 0.08 in. before reaching the limit of its travel. A gauge (Part No. A.210921) is provided for the purpose.

Adjusting nose wheel up micro-switch (fig.9 and 9B)

45. The nose wheel up micro-switch must be adjusted as described in fig.9B.

Adjusting front door lock mechanism and micro-switches (fig.8 and 8A)

46. The sequence of operations is as follows:-

- (1) With the lock operating rods (7) fig.8A removed, check the movement of the lever (4) port and starboard, which measured square to face (2), as shown, should be between 0.45 in. to 0.47 in. (Normally, in the case of existing doors, or doors supplied complete as spares, this movement will be correct. If it is not, see NOTE below before proceeding with operation (2).)
- (2) With the locks in the closed position, clamp the locks lightly with 'G' clamp at points (9) and inspect through holes (10) to ensure

that the hook and latch are engaged.

- (3) Fit the lock operating rods. With a 0.010 in. feeler at point (11), adjust the rods to bring the lever at the hinge bracket just in contact with the distance tube (5).
- (4) During the adjustment, ensure that the springs (8) are not compressed solid after full movement of the lock operating rods, i.e. with the stop face (3) in contact with the inside face of the hinge bracket.
- (5) With the stop (fig.8) in contact with the lock and with the lock in the closed position, adjust the gap between the micro switch plunger and the lever to 0.001 in. to 0.005 in. <sup>(0.015 in. Post Mod. 5/73)</sup> and lock the stop in position.

NOTE...

If new levers are fitted, or in other circumstances when the movement in operation (1) cannot be obtained, proceed as follows before carrying out operation (2) above.

- (6) Check that the lever clears the hinge bracket at (1) and file away the inside of the bracket at this point, if necessary, until the lever stops on stop face (3).
- (7) Lengthen the slots (6) to dimensions shown.
- (8) File the stop face (3) on the levers until the correct movement is obtained.

WARNING...

It is essential that none of the adjustments in the above operations are disturbed when the operating linkage between the jack and the door is adjusted.

## LUBRICATION

### General

47. The lubrication points for the complete alighting gear, together with the types of lubricant to be used, are shown in fig.10 and 11.

## MISCELLANEOUS

### Wheel brakes

48. The wheel brakes should not be interfered with unnecessarily once they have been correctly run-in, but if suspected of being faulty, the aircraft should be jacked up and the wheels removed. If the brakes are then found to be greasy, they should be removed. The removal of the wheels is described in A.P.2337, together with instructions for servicing and adjusting the brakes. An access door is provided in the wheel fairing to facilitate the servicing of the brakes and the removal of the brake upper cylinder. It is most important when replacing a wheel, that the nut collar should be adjusted to allow for wheel end play between the limits of 0.005 in. and 0.010 in. The procedure for doing so is described in the key to fig.12. When

replacing the wheels, reference should be made to the procedure for fitting and adjusting Maxaret units (Sect.3, Chap.6, para.45).

### Tyre wear

49. If the tyres show signs of slight wear, they may be removed from the wheels as described in A.P.2337 and re-fitted in the reverse position.

### Shock-absorber deflection

50. The procedure for checking the undercarriage shock-absorber deflection is described in Sect.2, Chap.2.

## REMOVAL AND ASSEMBLY

### General

51. The removal of the alighting gear is illustrated in fig.12 and 13 and the procedure for doing so is given in the keys to the illustrations. In general the assembly of the units is a reversal of the removal procedure.

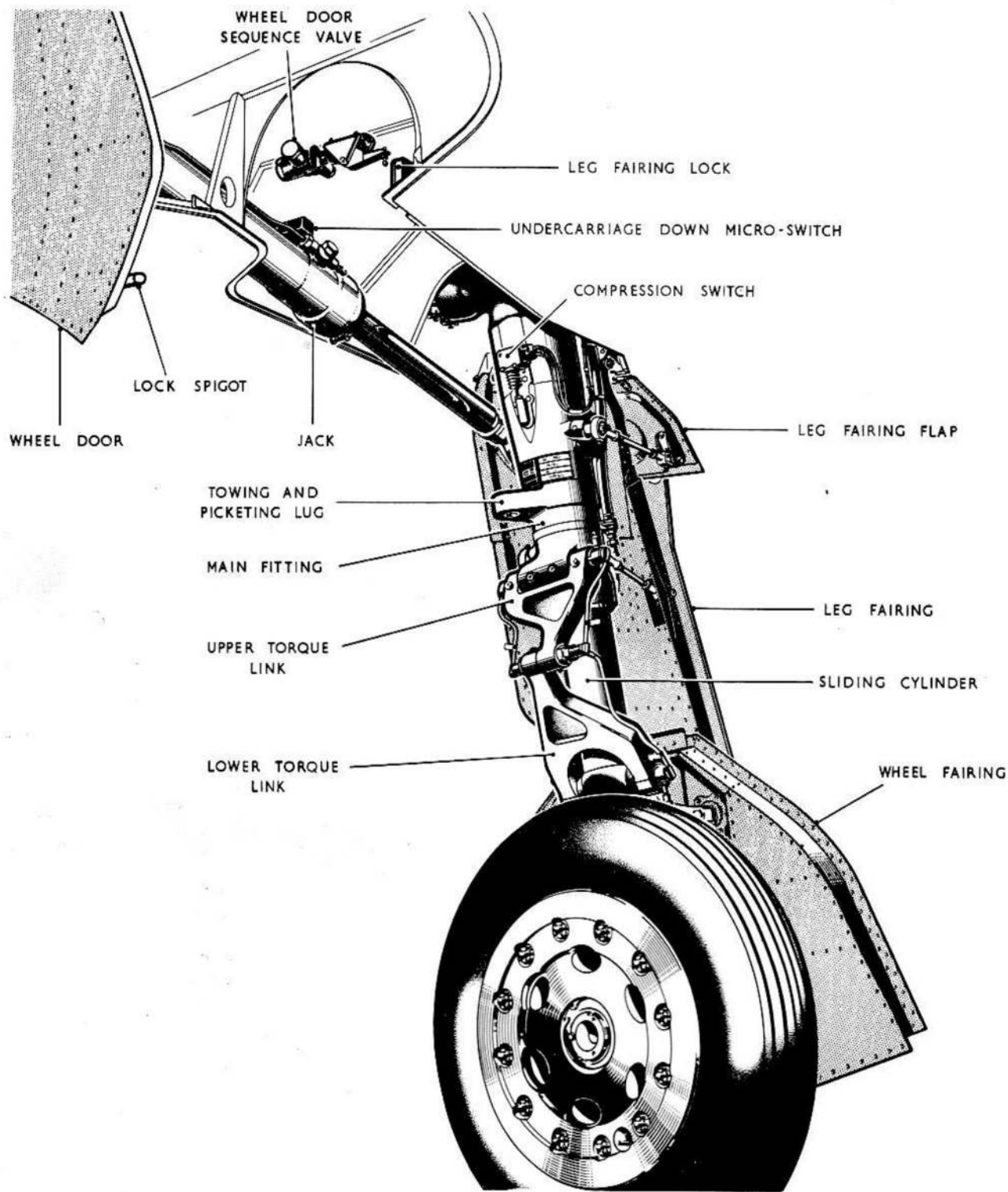

FIG. 1. MAIN UNDERCARRIAGE

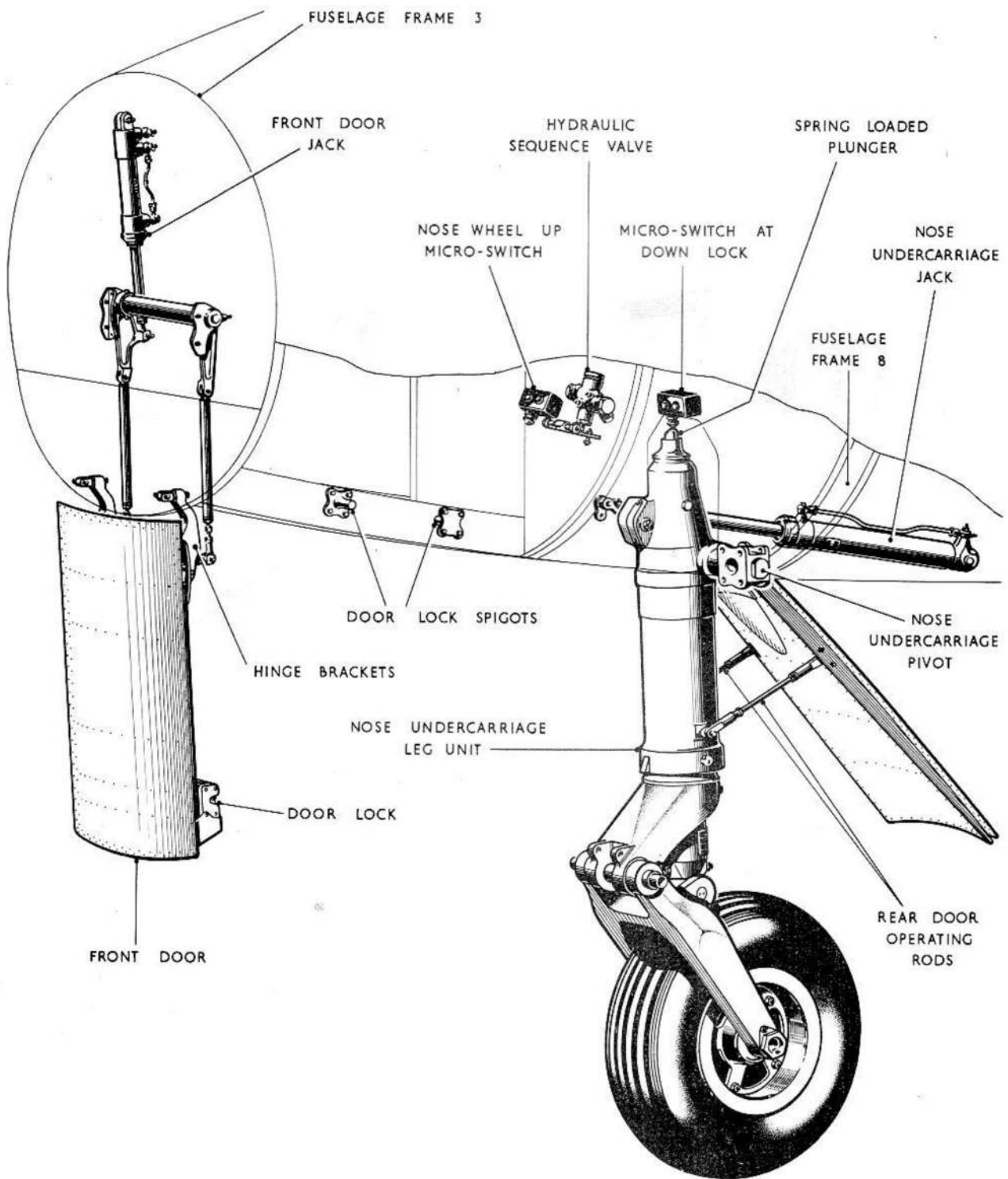

FIG. 2. NOSE UNDERCARRIAGE

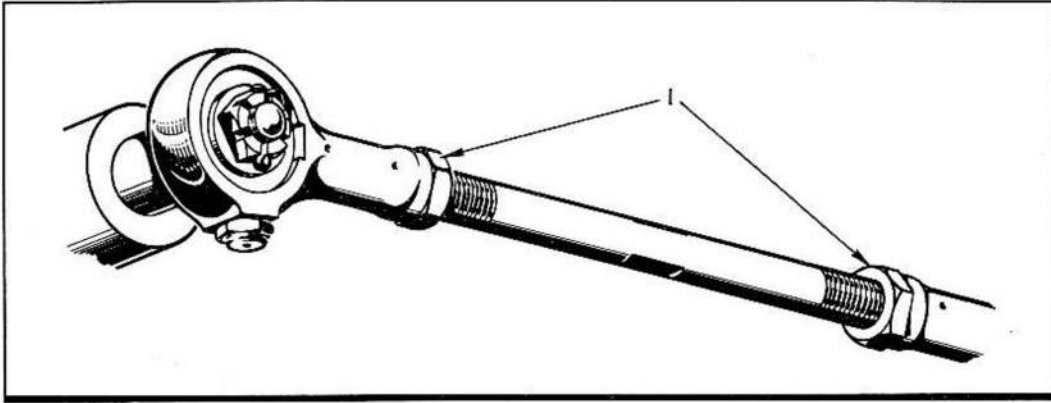

FIG. 4. LINK FOR UNDERCARRIAGE FAIRING AND FAIRING FLAP

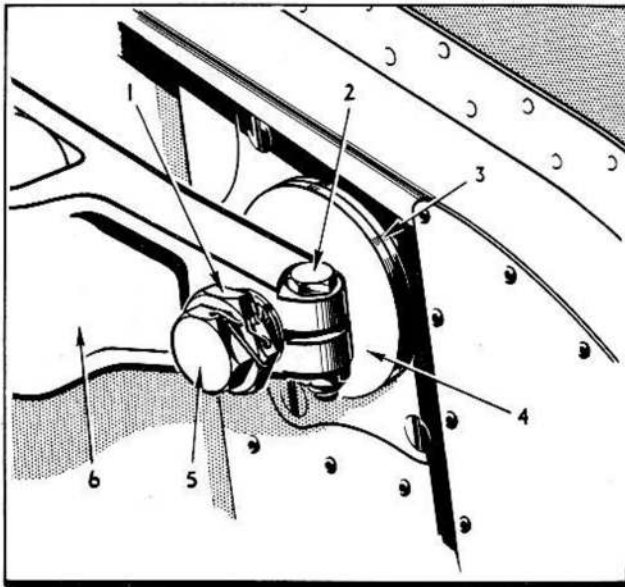

FIG. 3. WHEEL FAIRING ATTACHMENT

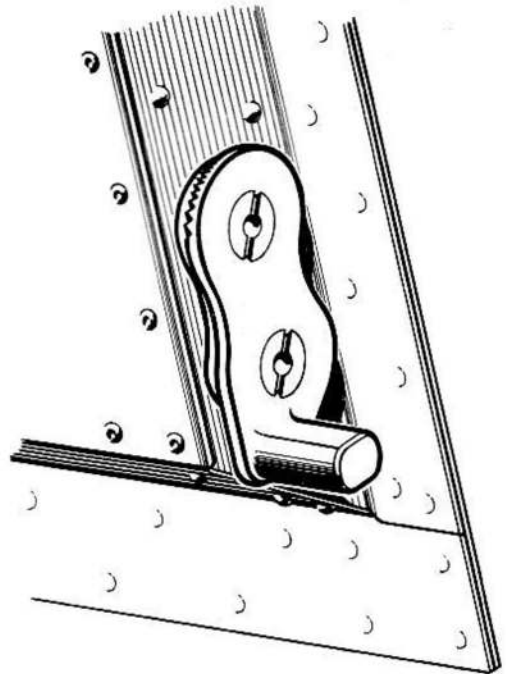

FIG. 6. LEG FAIRING LOCK SPIGOTS

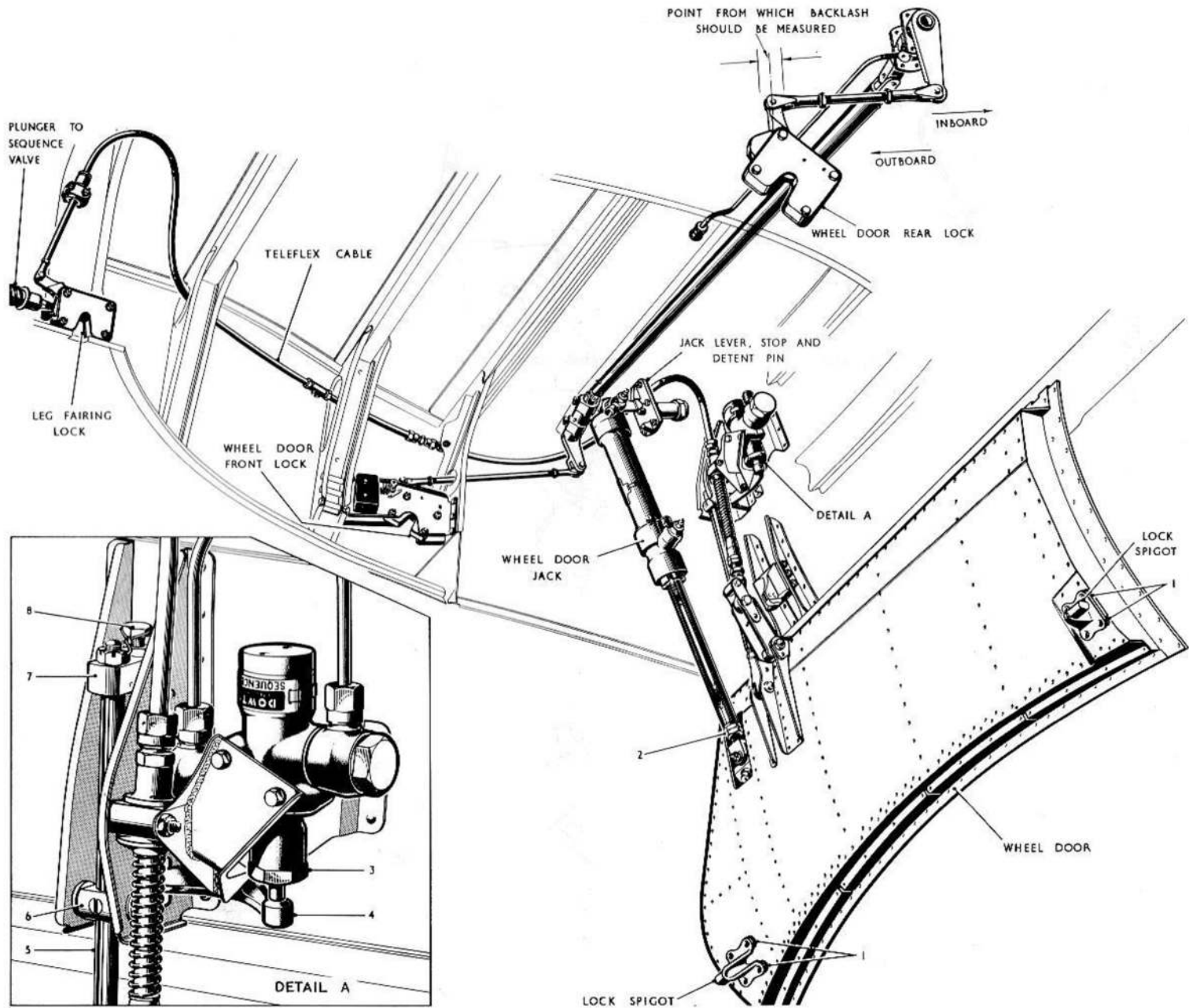

FIG. 5 MAIN UNDERCARRIAGE ADJUSTMENTS

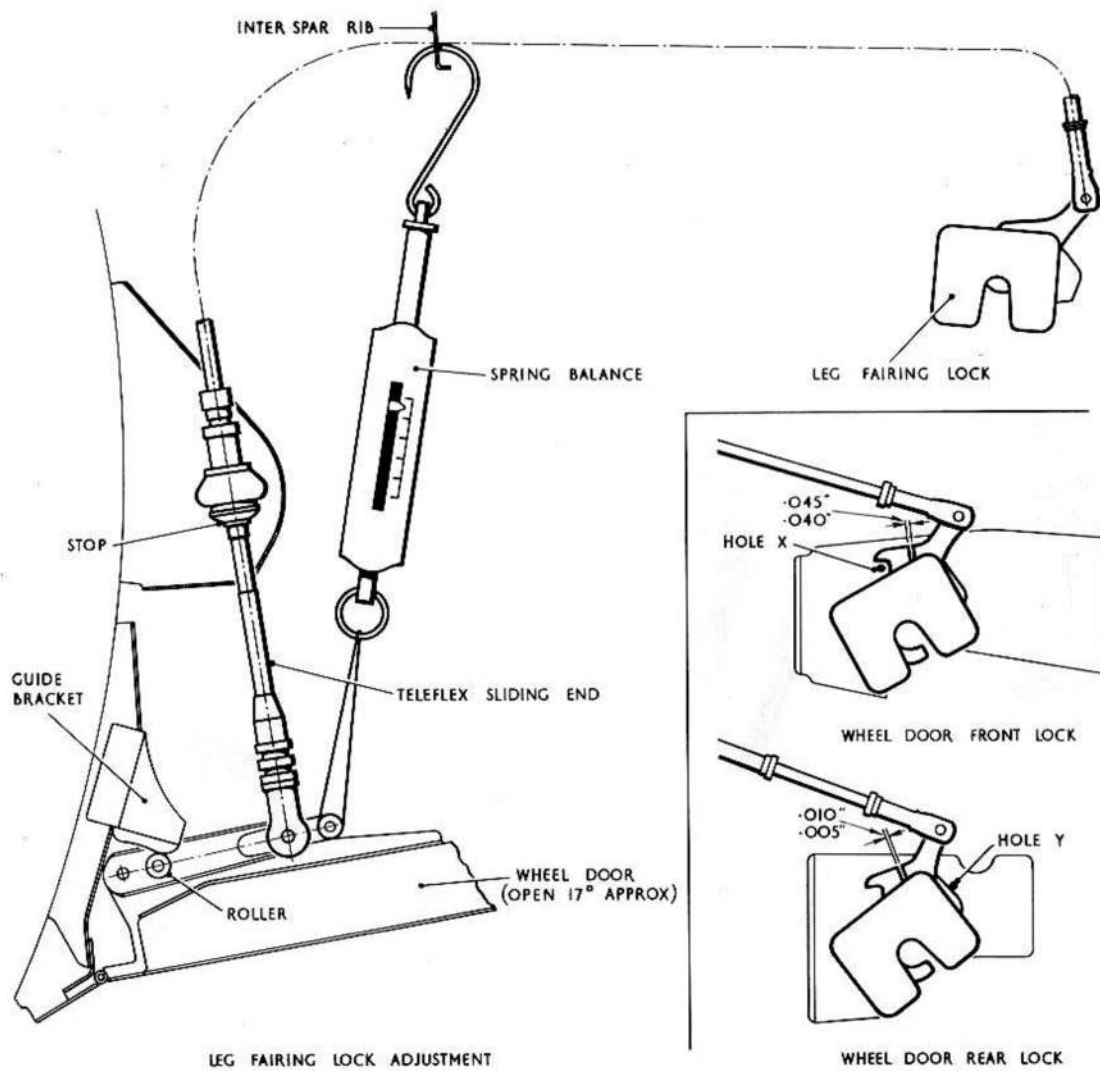

FIG. 5A. ADJUSTMENT OF MAIN UNDERCARRIAGE FAIRING LOCKS

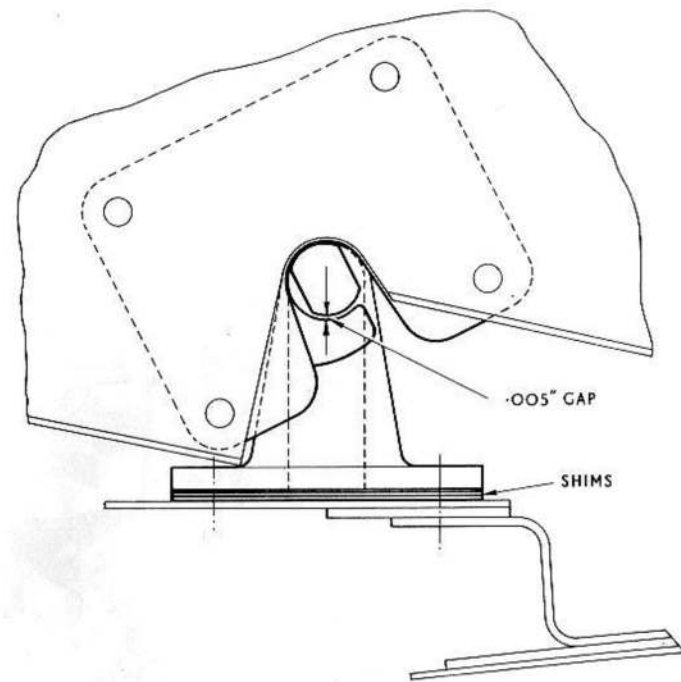
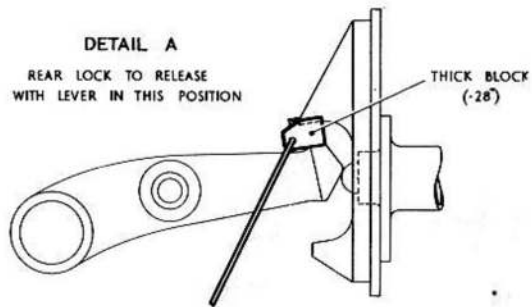
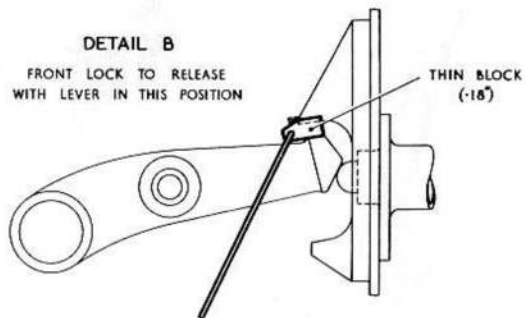

FIG. 6A VIEW SHOWING SPIGOT ON WHEEL DOOR ENGAGED IN LOCK



FOR REAR LOCK OPERATION



FOR FRONT LOCK OPERATION

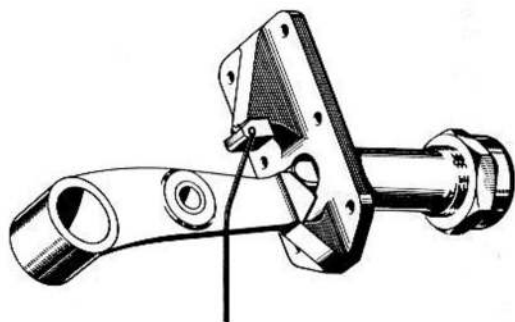

VIEW OF JACK LEVER WITH GAUGE IN POSITION  
 BEFORE HAND PUMP OPERATION COMMENCED

FIG. 6B WHEEL DOOR LOCKS —  
 USE OF GAUGE FOR ADJUSTMENT

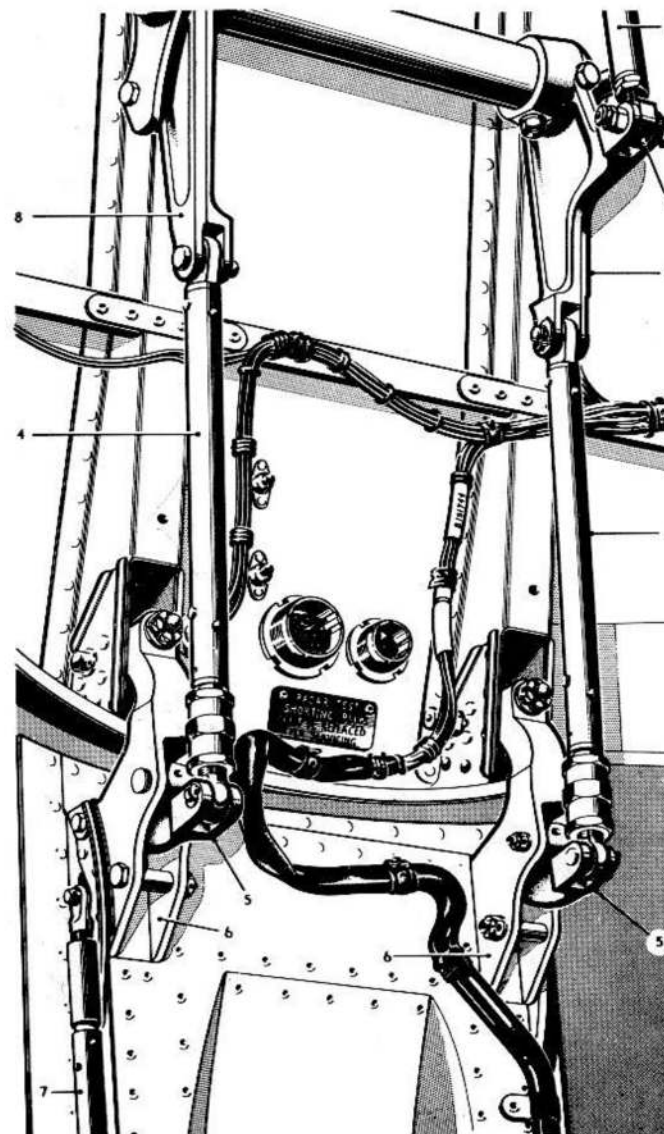

FIG. 7. NOSE UNDERCARRIAGE ADJUSTMENTS (1.)

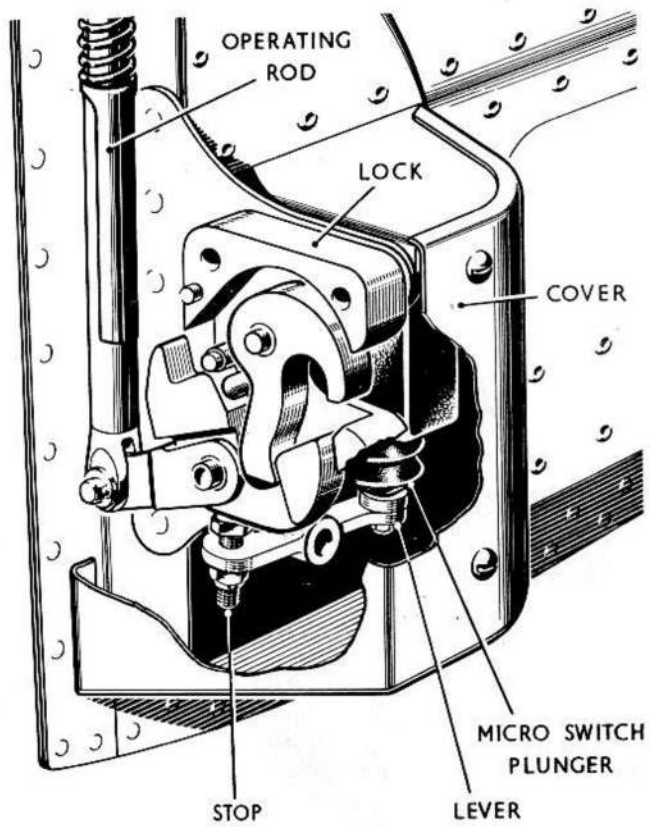

FIG. 8. NOSE UNDERCARRIAGE ADJUSTMENTS (2.)

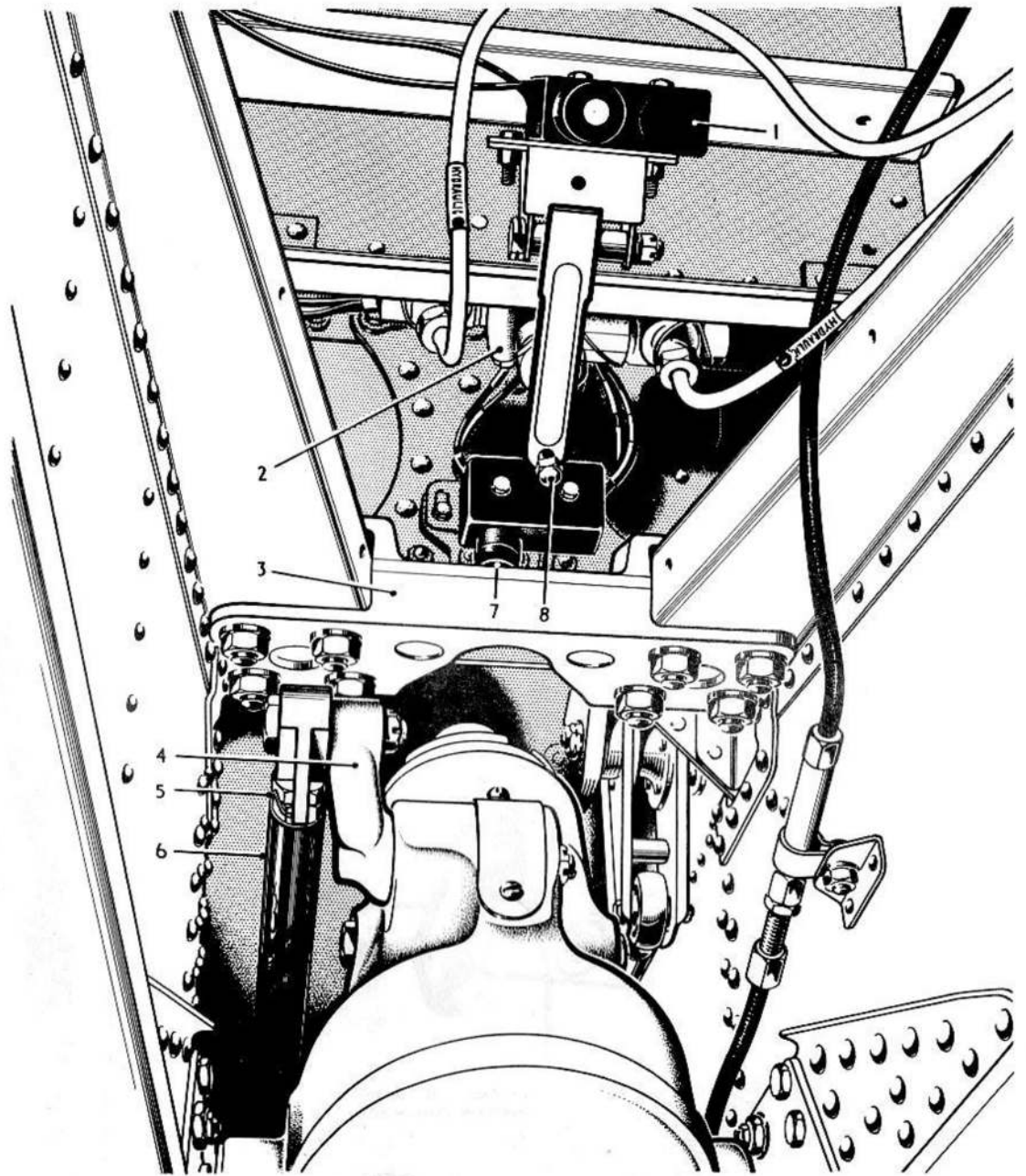
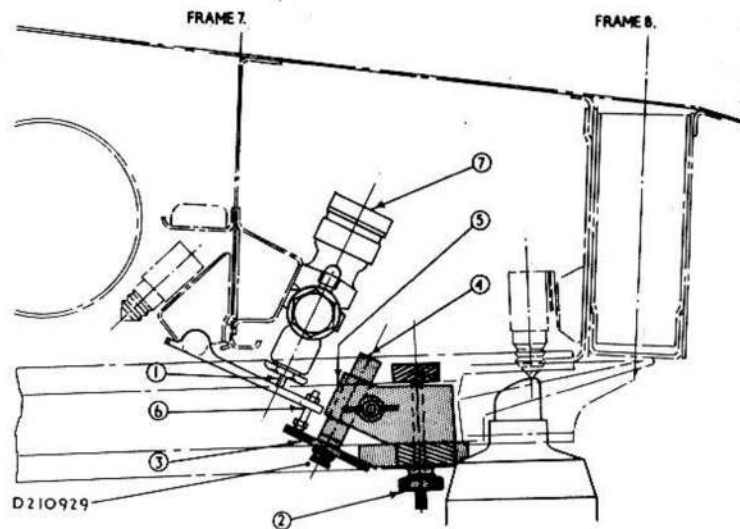

FIG. 9. NOSE UNDERCARRIAGE ADJUSTMENTS (3.)



WITH THE LEG IN THE FULLY RETRACTED POSITION, THE SEQUENCE VALVE PLUNGER 1 MUST BE DEPRESSED 0-0 1/2 IN. TO 0 1/2 IN. TO ENSURE THAT THE VALVE IS FULLY OPEN. THE PROCEDURE IS AS FOLLOWS:—

WITH NOSE WHEEL LOWERED, SLIDE THE NOSE WHEEL DOOR SEQUENCE VALVE SETTING JIG, PART No. D210929 REF. OVER TOP HAT STIFFENERS ON KEEL MEMBER SO THAT IT BEARS HARD UP AGAINST NOSE WHEEL LOCK. TIGHTEN NUTS 2 AND REMOVE 3, SLACKEN WING NUT AND ALLOW 4 TO FALL LEVEL WITH TOP OF BLOCK 5. RETRACT LEG WHICH PUSHES 4 UP, LOCK WING NUT, CHECK IF LEG IS AGAINST THE STOP BLOCK BY LOOKING THROUGH LIGHTENING HOLE IN KEEL MEMBER, LOWER LEG SCREW 3 INTO SPIGOT 4, ADJUST BOLT 6 HARD DOWN TO FACE OF 3, LOCK BOLT WITH LOCKING NUT. REMOVE JIG.

FIG 9A. METHOD OF SETTING NOSE WHEEL DOOR SEQUENCE VALVE

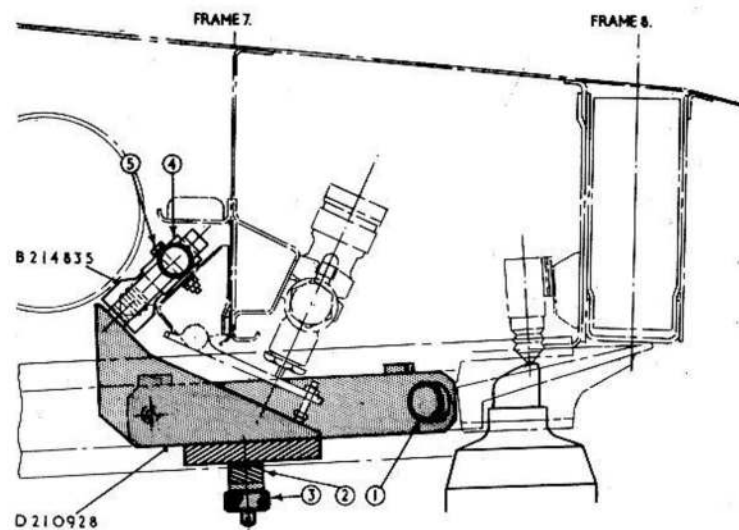

WITH THE LEG IN THE FULLY RETRACTED POSITION, IT IS IMPORTANT THAT THE MICRO SWITCH PLUNGER CAN BE DEPRESSED A FURTHER 0-0 8 IN.. THE PROCEDURE FOR ADJUSTING THIS IS AS FOLLOWS:—

WITH NOSE WHEEL LOWERED, SLIDE SETTING JIG PART No. D210928 ALONG TOP HAT STIFFENERS. ENGAGE PIN 1 IN AFT TOOLING HOLE IN EACH STIFFENER AND TIGHTEN UP CLAMPING BAR 2, BY MEANS OF KNURLED NUTS 3, TO SET MICRO SWITCH 4, LOOSEN BOLTS 5 SECURING SWITCH TO THE AIRCRAFT STRUCTURE. FIT SETTING GAUGE PART No. B214835 TO FULLY DEPRESS SWITCH, THEN MOVE SWITCH UP OR DOWN AS NECESSARY TO CONTACT THE SETTING JIG PART No. D210928. TIGHTEN UP BOLTS 5 AND REMOVE SETTING GAUGE AND JIG.

FIG 9B. METHOD OF SETTING NOSE WHEEL DOOR UP-MICRO-SWITCH

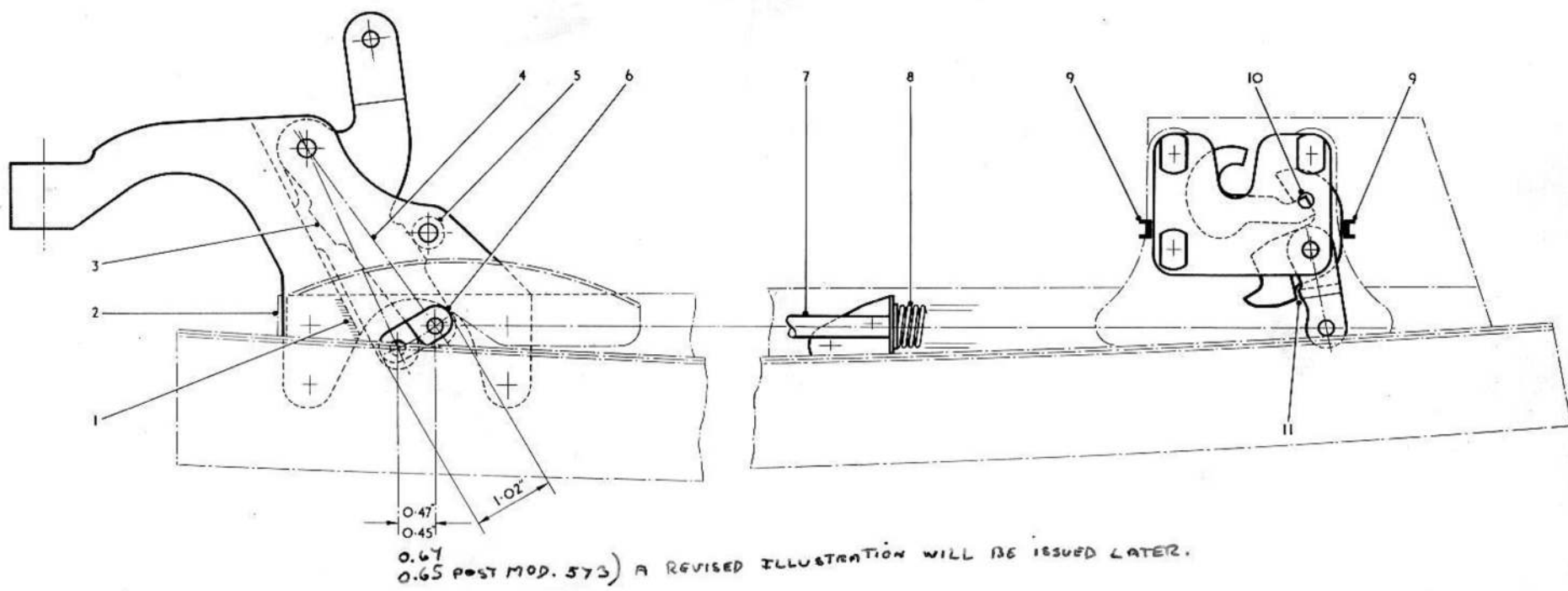

FIG. 8A ADJUSTMENT OF NOSE WHEEL DOOR LOCK MECHANISM AND MICRO SWITCH

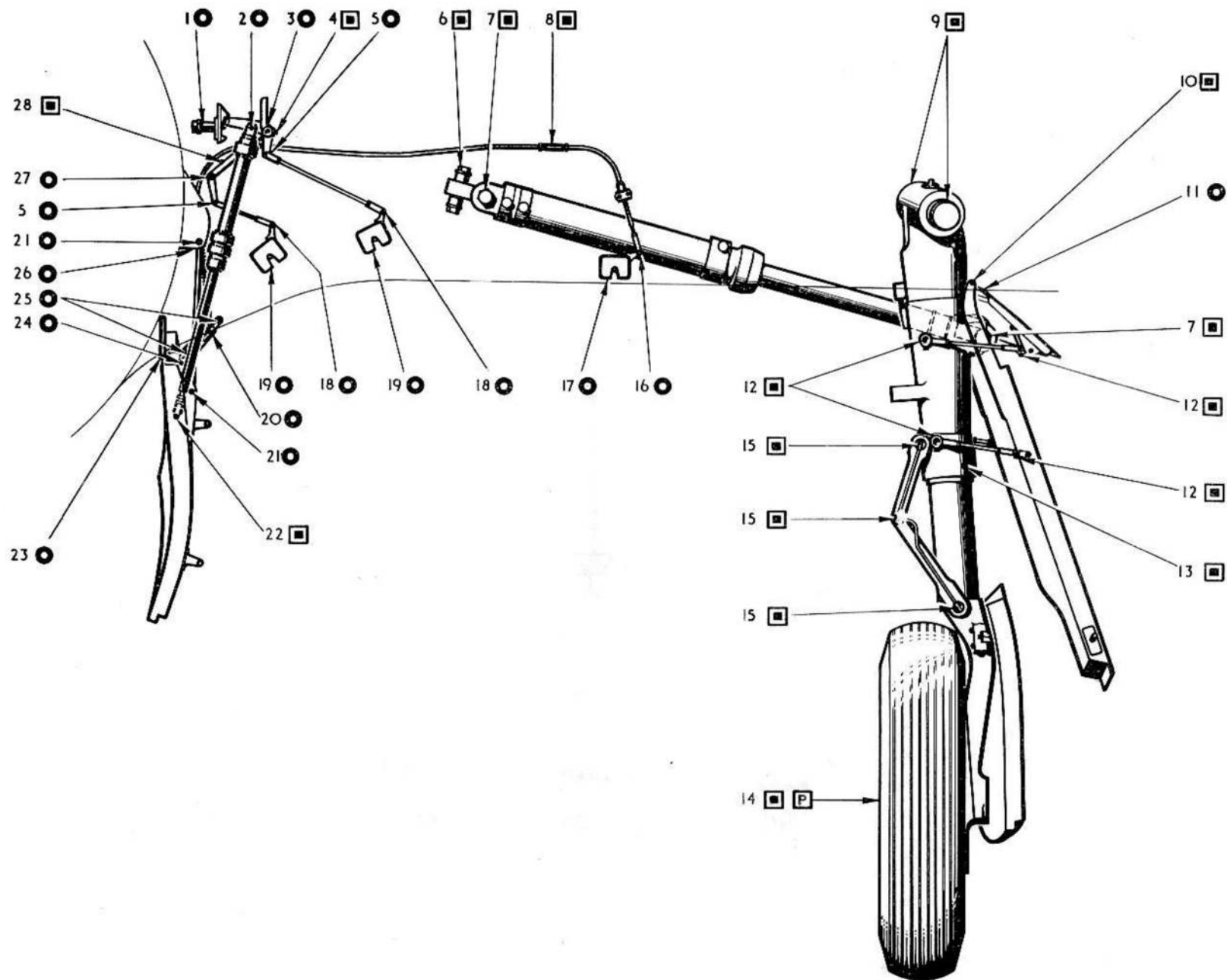

FIG. 10. UNDERCARRIAGE LUBRICATION (I.)

## MAIN U/C LUBRICATION

- |   |  |
|---|--|
| 1. Detent pin.  | 14. Wheel.   |
| 2. Wheel door jack pivot.   | 15. Upper and lower torque links.  |
| 3. Universal joint on shaft.  | 16. Leg fairing lock link.   |
| 4. Front bearing bracket for shaft.   | 17. Leg fairing lock.  |
| 5. Operating lever.   | 18. Wheel door lock link.  |
| 6. Undercarriage jack pivot.  | 19. Wheel door lock.   |
| 7. Undercarriage jack pivot.  | 20. Teleflex self aligning end.  |
| 8. Teleflex control.  | 21. Wheel door down stop rod, trunnion and pivots.                               |
| 9. Undercarriage pivot.<br>(For a/c with undercarriage legs to Dowty Mod.AC.2909 the a/c should be jacked up and the legs partially (1/3 approx.) retracted before greasing.) | 22. Jack anchorage.  |
| 10. Leg fairing hinges.   | 23. Wheel door hinge.  |
| 11. Fairing flap hinges.  | 24. Teleflex control lever hinge.  |
| 12. Connecting links.   | 25. Teleflex control lever rollers.  |
| 13. Undercarriage leg.  | 26. Sequence valve lever.  |
|   | 27. Universal joint on shaft.  |
|   | 28. Rear bearing bracket for shaft.<br>(Lubricated via extended greaser nipple). |

- Oil OX-14, Stores Ref.34B/250 or 34B/255.
- Grease XG-275, Stores Ref.34B/222 or 34B/242.
- Pack with Grease on Assembly.

KEY TO FIG.10

## NOSE U/C LUBRICATION

1. Front door jack pivot.
2. Cross shaft brackets.
3. Sequence valve operating lever.
4. Spring-loaded plunger.
5. Undercarriage pivot.
6. Undercarriage jack pivot.
7. Rear door hinges.
8. Rear door operating rods.
9. Shock absorber unit.
10. Nose wheel.
11. Wheel fork.
12. Nose undercarriage leg.
13. Rear door operating rod spring.
14. Undercarriage jack retracting arm.
15. Front door operating rod.
16. Lock operating lever.
17. Front door operating rod.
18. Front door lock.
19. Front door operating rod.
20. Front door hinges.
21. Front door operating lever (starboard).
22. Front door operating rod.
23. Front door operating rod.

- Oil OX-14 Stores Ref. 34B/250 or 34B/255
- ◻ Grease XG-275 Stores Ref. 34B/222 or 34B/242
- Pack with grease on assembly.

KEY TO FIG. 11

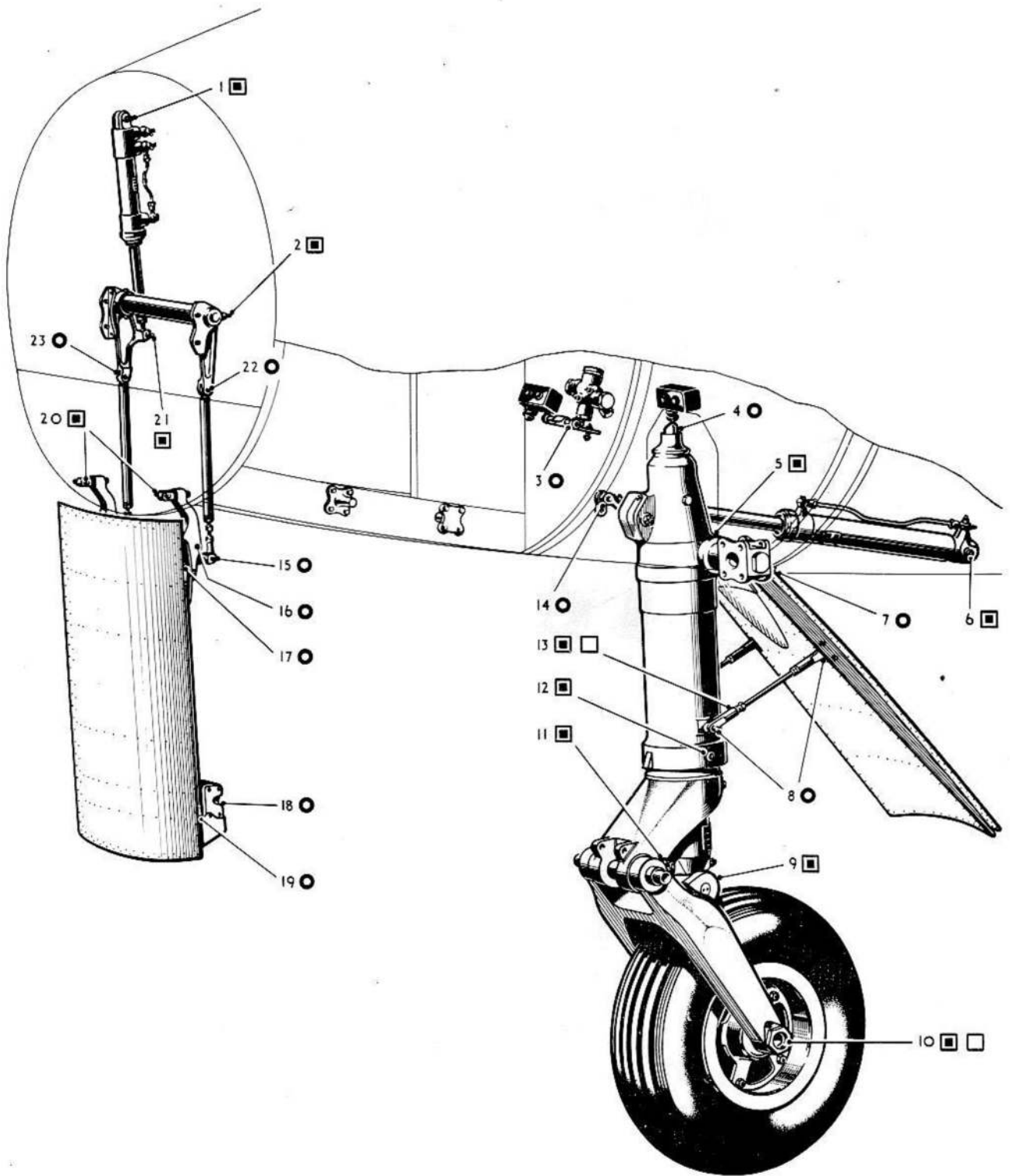

FIG. II. UNDERCARRIAGE LUBRICATION (2.)

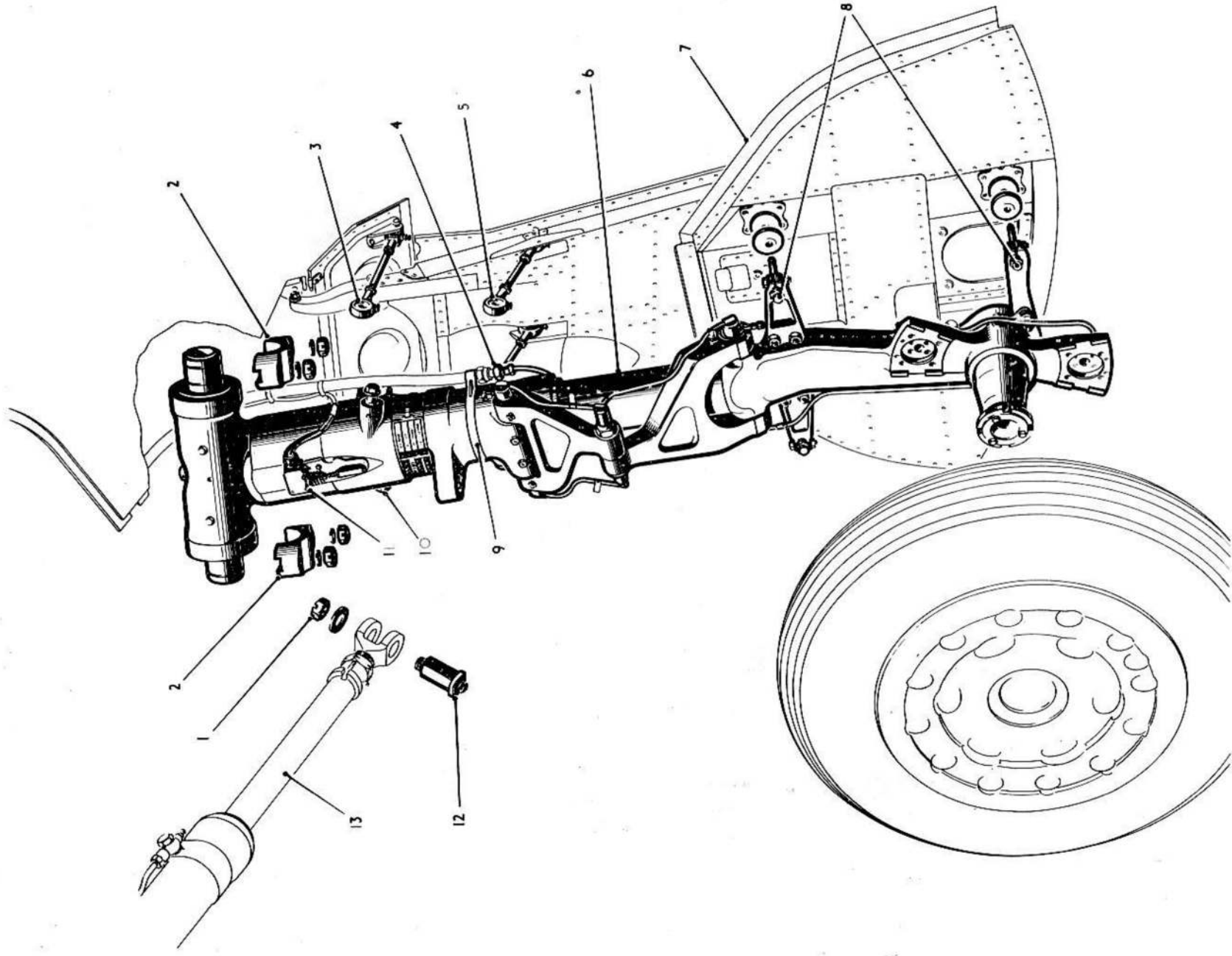

FIG. 12. MAIN UNDERCARRIAGE REMOVAL

## MAIN U/C REMOVAL

With the aircraft jacked (Sect.2, Chap.4) and the undercarriage locked down.....

Ensure that the undercarriage is in the 'Locked down' position and attach the U/C safety stops to the Nose U/C and the Main U/C Leg not being removed.

Remove the wheel (A.P.2337, Vol.1).

Unscrew the 4 bolts (8) and remove the wheel fairing (7).

Remove the 2 bolts attaching the compression switch (11) to the leg.

Remove the clip (9) securing the brake pipe to the leg and disconnect the coupling (4) immediately below.

Unscrew the jack pivot pin slotted nut (1) and withdraw the pin (12).

Retract the jack (13) sufficiently to clear the eye end (10) on the leg retraction pin and to allow removal of the leg.

Disconnect the links (5) attaching the leg fairing to the leg (6).

Disconnect the link (3) attaching the fairing flap to the leg.

Support the undercarriage leg and remove the split pins, slotted nuts and washers from the two bearing caps (2) for the pivot fitting and ease the leg away from the aircraft.

## NOTE..

After replacing the wheel, tighten the nut collar as far as possible while the wheel is being spun. The collar must then be turned anti-clockwise until one of the holes in the collar is in line with the nearest locking slot in the axle. Rotate the collar still further in the same direction until the next hole lines up with the locking slot. This adjustment will ensure that the wheel end play is within the stipulated allowance of 0.005 in. and 0.010 in.

## NOSE U/C REMOVAL

With the A/C jacked and the undercarriage lowered.....

Remove the split pins, nuts and washers from the nose U/C rear door operating rods (5) port and starboard. Pull the rods off the studs on the U/C leg unit and allow them to swing free. Fasten the rear door in the open position.

Disconnect the nose U/C operating jack (2) from the jack retracting arm (1) on the leg unit (6) by removing the split pin, slotted nut and bolt.

Take off the port and starboard access doors (4) under fuselage frame 8. Remove the blast tubes at the inboard guns.

Remove the nut and washer on the U/C leg pivot pin (3) from the starboard side of the aircraft. Support the U/C, withdraw the pivot pin through the port access door opening, draw the leg forward and lower it from the aircraft.

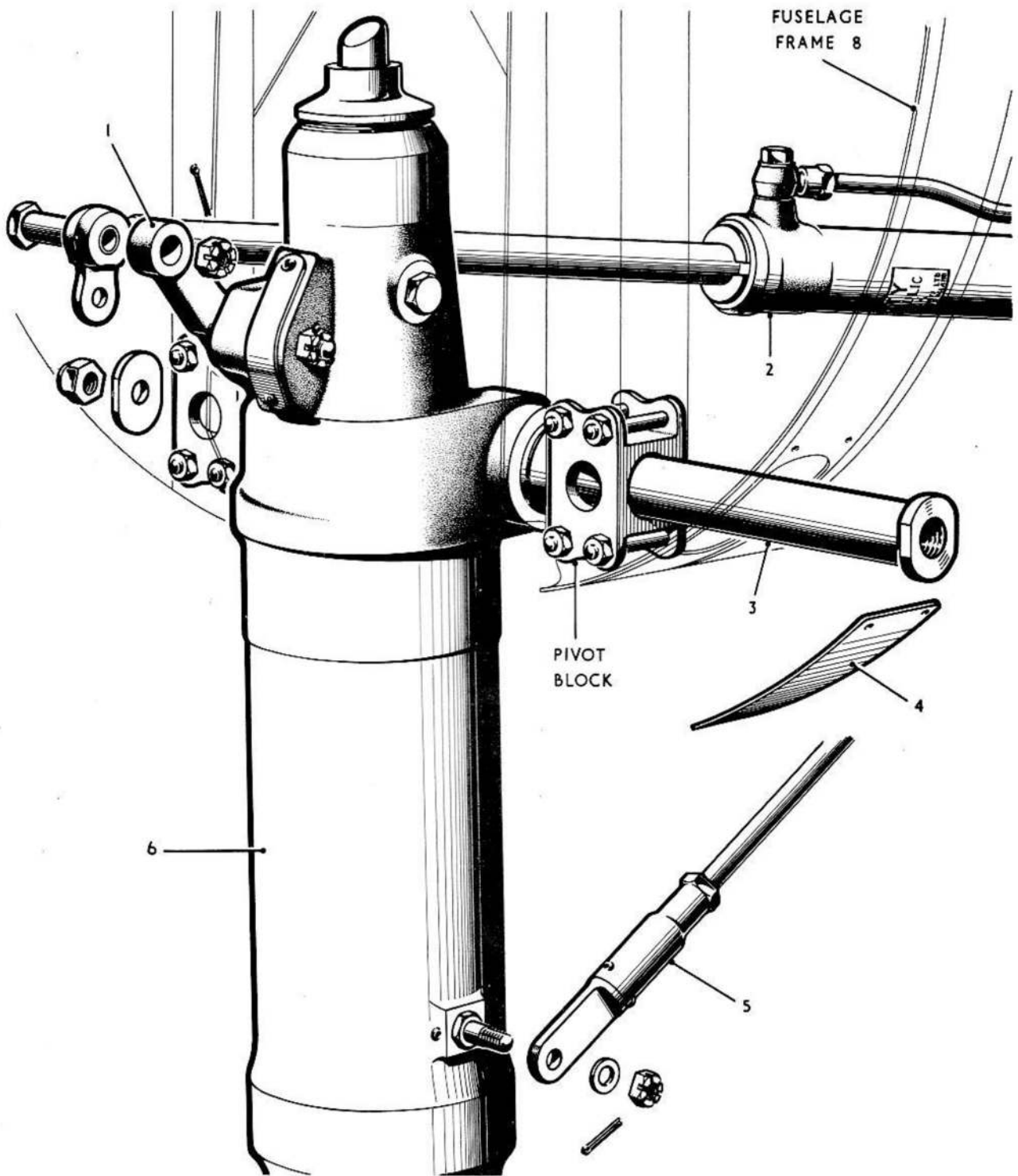
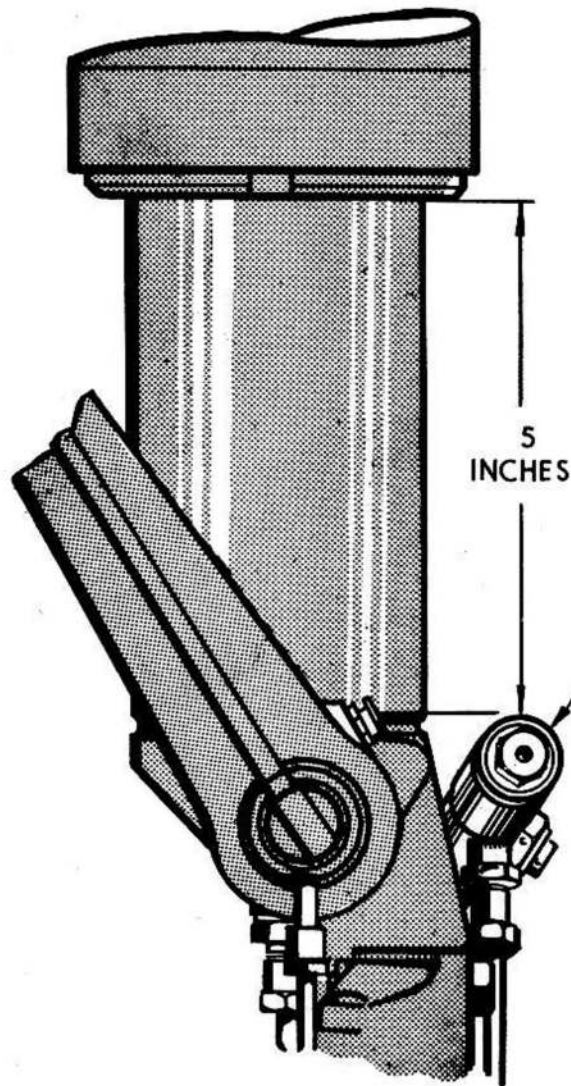

FIG. 13. NOSE UNDERCARRIAGE REMOVAL



### IMPORTANT

#### PROCEDURE FOR LOWERING A/C OFF JACKS

1. BEFORE LOWERING A/C OFF JACKS UNSCREW SERVICING VALVE OUTWARDS TO STOP.
2. PRESSURISE HYDRAULIC SYSTEM TO 1,500 PSI. MIN., USING A/C HAND PUMP OR GROUND TEST RIG.
3. LOWER A/C OFF JACKS.
4. SCREW SERVICING VALVE FULLY IN.

SERVICING VALVE

#### INDICATIONS WHEN MAIN U/C LEGS MUST BE RE-CHARGED

WHEN CHECK DIMENSION IS LESS THAN 5" AS SHOWN IN THE DIAGRAM AND/OR WHEN THE DIFFERENCE BETWEEN PORT AND STBD. LEGS IS GREATER THAN ONE INCH

Fig.14 Main u/c deflection check & re-charging

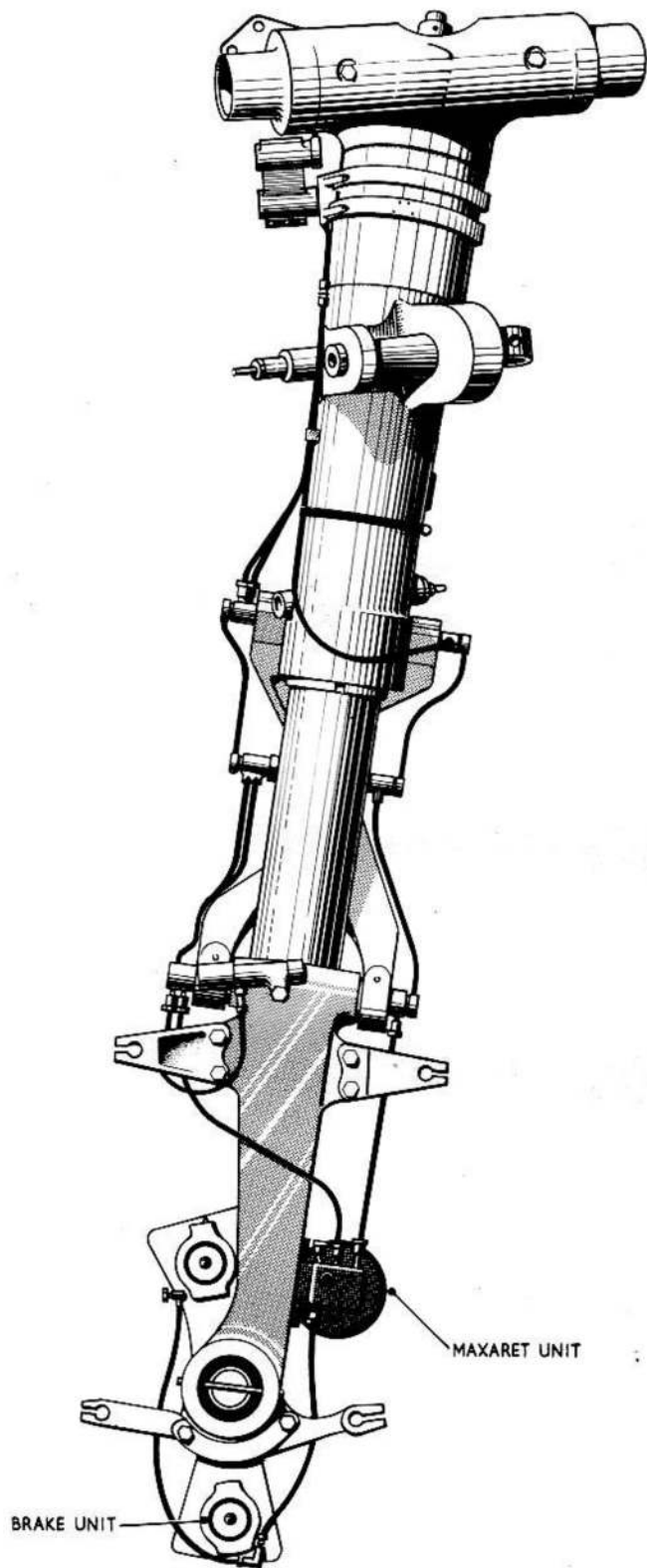

FIG.15 ASSEMBLY OF BRAKE UNITS (MAXARET TYPE) TO U/C LEG

This file was downloaded  
from the RTFM Library.  
Link: [www.scottbouch.com/rtfm](http://www.scottbouch.com/rtfm)

Please see site for usage terms,  
and more aircraft documents.

