

GROUP A.1

SYSTEM DETAILS

LIST OF CONTENTS

	<u>Para.</u>		<u>Para.</u>
Introduction	1	Switchboxes	23
Referencing and general servicing of components		Terminal blocks	24
Junction boxes	4	Filament lamps	25
Servicing of junction boxes	5	Earth points	26
Generator control and supply panels	7	General servicing of system	
Leg panel	8	External supply socket	27
Cabin port shelves	9	Rendering aircraft electrically safe	28
Cabin starboard shelf	10	Use of spare cables for emergency servicing	29
Gun-firing panel	11	Insulation resistance testing	30
Radio relay box	12	Interpretation of diagrams	
Servicing of panels and shelves	13	General	31
Cable assemblies	14	Method of reading a theoretical diagram ...	34
Cables	16	Method of reading a routing chart	36
Multi-pole plugs and sockets	17	Cable abbreviations	37
Fuses	20	Loading chart and circuit index	38
Circuit breakers	21	Junction box, panel, and shelf wiring diagrams	39
Relays	22		

LIST OF TABLES

	<u>Table</u>
Circuit breakers	1
Filament lamps	2
Cable abbreviations	3

LIST OF ILLUSTRATIONS

	<u>Fig.</u>		<u>Fig.</u>
Supply and earth routing chart	1	Wiring of J.B.1.	4*
Available spare wiring	2*	Wiring of J.B.2.	5
Loading chart and circuit index	3*	Wiring of J.B.3.	6
		(* To be issued later)	

	<u>Fig.</u>
Wiring of A.C.J.B.	7
Wiring of generator control panel	8
Wiring of supply panel	9 *
Wiring of leg panel	10 *
Wiring of cabin port shelf (forward portion	11 *
Wiring of cabin port shelf (rear portion).	12 *

(* To be issued later)

Introduction

1. This group contains a general description of the electrical system as a whole, together with wiring details and general servicing information. Tables listing the ratings and Stores References of the circuit breakers and filament lamps are also given, together with a loading chart including a circuit index. Illustrations showing the wiring of the junction boxes, panels and shelves including the fuse details will also be found in this group. For detailed information on the standard items of equipment, reference should be made to the appropriate Air Publications, a list of which will be found at the beginning of this volume.

2. This system is of the 24-volt, single-pole, earth return, voltage regulated type. It is supplied by two Type 517 generators, connected in parallel and stabilized by two Type C, 12-volt, 25 amp. hour batteries, which are connected in series and float across the output of the generators. The batteries are provided with a protective cover. The wiring cable assemblies are run between junction boxes and panels located at points convenient for distribution to the equipment and for breaking down the aircraft. The majority of the cable assemblies are provided with fully weatherproof multi-pole plug and socket breakdown points. Whenever possible the cable connections to the plug and socket pins are crimped. To facilitate servicing and testing, the

	<u>Fig.</u>
Wiring of cabin starboard shelf	13*
Wiring of ARM J.B.1.	14
Wiring of ARM J.B.2.	15
Wiring of ARM J.B.3.	16
Wiring of ARM J.B.4.	17
Wiring of ARM J.B.5.	18
Wiring of ARM J.B.6.	19

earth return connections are restricted and taken to a number of stud type earth points, which are shown on the cable assembly layout, (Group A.3, fig.1) and listed on the supply and earth routing chart, fig.1 of this group.

3. The generators are mounted on, and driven by the auxiliary gearbox situated in the engine bay, and their control equipment is mounted on a panel located on the starboard side of the radio bay. The batteries are mounted on a platform also located in the radio bay. The supply from the generators and batteries to the fuse bus-bars is shown, together with the earth return points, on fig.1 of this group.

Referencing and general servicing of components

Junction boxes

4. These are of welded aluminium, waterproof construction with the insides suede-finished to obviate chafing and condensation. They contain the terminal blocks and certain other equipment and apart from the A.C. junction box, are referenced numerically, the numbers being preceded by the letters J.B. or in the case of the armament junction boxes with the additional letters ARM. Each box contains a wiring diagram, a copy of which will be found in this group. The terminals in the boxes are numbered and may be

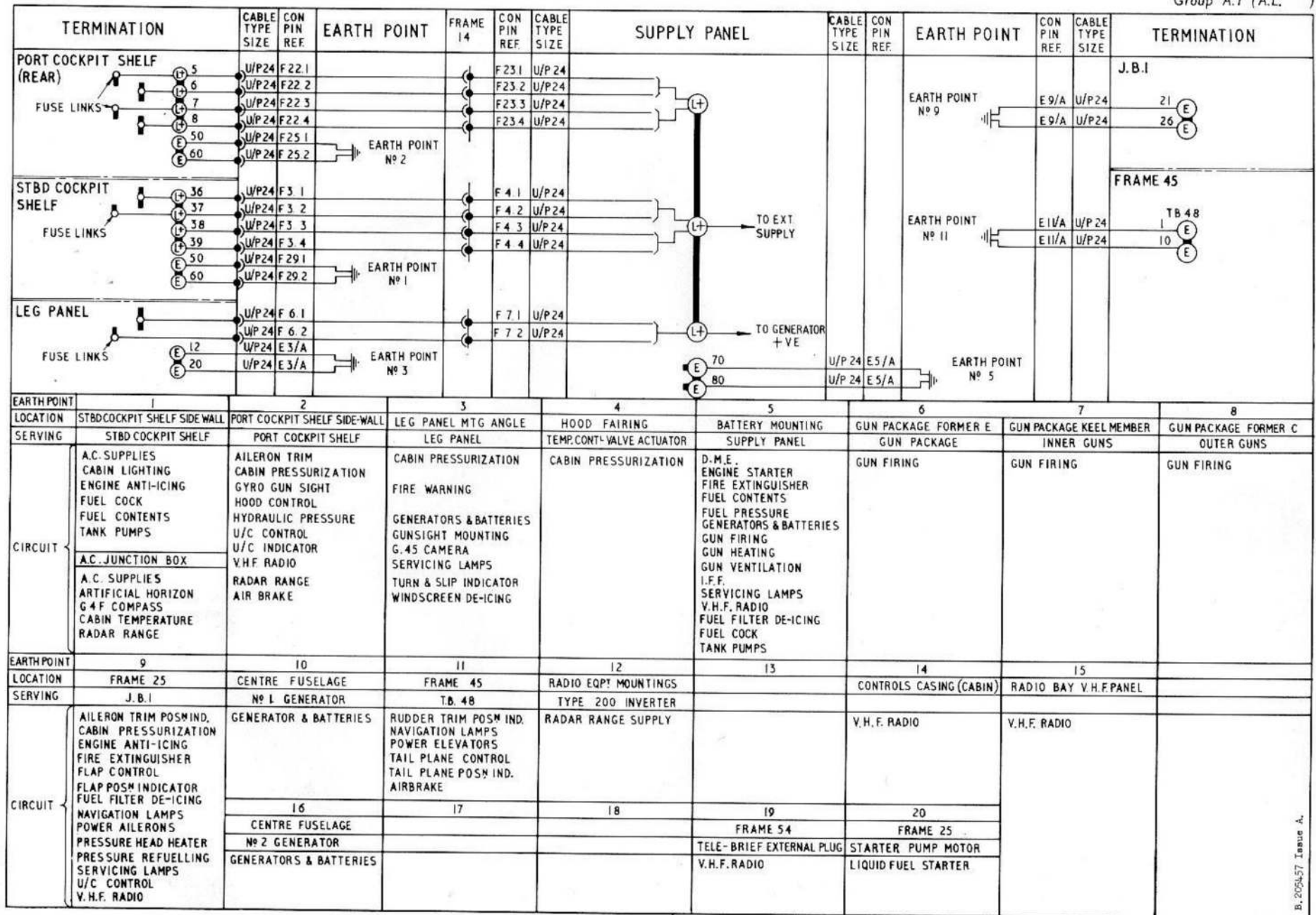

FIG. 1. SUPPLY AND EARTH ROUTING CHART

identified by reference to the wiring diagrams, spare terminals are starred to denote that they are spares. Where a cable passes through a box without connecting to a terminal the cable is wired pin to pin between its associated plugs, i.e., pin A to pin A or pin B to pin B, etc. The cable outlets of J.B.1 are mainly of the multi-pole plug and socket type, while at J.B.2 the outlets are of the rubber grommet type. Junction box number 1 is the major box and is located at the bottom of the centre fuselage on the rear face of the main spar. Junction box 2 is located on the port side of the front fuselage above the cabin shelf between frames 11 and 12, and is used mainly for distribution to the equipment on the port side of the cabin. Junction box 3 is mounted on the engine auxiliary **gearbox access door** and is used to interconnect the engine **starter** equipment. Junction box 4 is situated in the cabin on the starboard side of the floor behind the seat and is employed in the A.C. supplies circuit. The A.C. junction box is mounted aft of the cabin starboard shelf and used to supply the flight instruments and radar installation. Junction box ARM J.B.1. is located on the fuel tank access door on the forward face of frame 19 above the battery platform, while ARM J.B.2 is mounted aft of the cabin port shelf. ARM J.B.3 and 4 are located in the port wing, being mounted to the top skin of the wheel bay and the diaphragm between interspar ribs Q and R respectively. ARM J.B.5 and 6 are located in similar positions in the starboard wing. All these junction boxes are used as breakdown and distribution points for the armament services.

Servicing of junction boxes

5. A regular examination of the junction boxes should be carried out to ensure that they are correctly supported, clean and undamaged. All the components in the boxes should also be examined for security, and an examination of the wiring and terminals made, for damage and corrosion.
6. The junction boxes are provided with readily

detachable lids and have been designed for ease of removal, being supported on quick-release mountings. When major servicing is necessary, it is recommended that the boxes are removed from the aircraft and replaced with fully serviced components, thus reducing the time in which the aircraft is unserviceable. The faulty boxes should then be serviced, on the bench, and returned to store to be held as spares. The method of removing the boxes is described in Group A.2 of this chapter.

Generator control and supply panels

7. These two panels are located together between frames 16 and 19 on the starboard side of the radio bay in the front fuselage. The supply panel is outboard of the generator control panel and is curved to conform with the inside contour of the fuselage skin, being attached by studs on frames 17 and 18, which engage with channel members on the panel. The panel carries a number of terminal blocks, fuse boxes and relays, together with plugs for the cable assemblies to and from the panel. The generator control panel is hinged to the top longeron and fits over the supply panel to form a lid, being attached to the latter panel by four Dzus fasteners along its lower edge. The panel contains all the generator control components, fuse boxes and testing equipment. When raised for access to the supply panel, the generator control panel may be retained in the up position by a hook attached to a length of chain secured to the radio mounting structure.

Leg panel

8. This panel is in the form of a box, being bolted to the cabin floor, below the centre instrument panel and just forward of the control column. It is provided with a hinged door on the port side and a sloping plate carrying the plugs for the cable assemblies on its forward face. The rear face carries the oil pressure gauge, generator

power failure warning lamps, ignition and starter switches, together with the gyro gun sight circuit breaker and a number of control switches. The box contains relays, terminal blocks and fuse blocks, these latter components being mounted on the inside face of the door for easy accessibility.

Cabin port shelves

9. The cabin port shelf, as a whole, extends between frames 8 and 12, and the two portions about to be described form removable parts of this structure. The forward portion is located just inboard of the throttle lever at the forward end of the structure, while the rear portion extends aft from just behind the bomb/R.P. control box to the end of the structure. Each portion is attached to the fixed structure by a number of screws and Dzus fasteners and is in the form of a panel with a side member. The rear portion is also provided with an end plate which carries the plugs for connection with the cable assemblies, to and from this shelf. The panels carry the radio controllers, control switches, warning lamps and indicators, while below a hinged door, in the top surface of the rear portion, are a number of terminal and fuse blocks supplying the equipment.

Cabin starboard shelf

10. This shelf, of which the removable portion about to be described is the major part, extends between frames 8 and 12. The removable portion is attached to the fixed structure by a number of Dzus fasteners and is in the form of a panel with a side member and end plate. The end plate carries the plugs for the cable assemblies to and from the shelf while the panel incorporates a number of switches and circuit breakers, together with the fuel contents gauges: below a hinged door, at its rear end, are a number of fuse and terminal blocks supplying the equipment.

Gun-firing panel

11. This panel is bolted below the radio mounting structure on the port side of the front fuselage and carries the gun-firing equipment, consisting of an inverter and a number of relays, together with terminal and fuse blocks supplying the equipment.

Radio relay box

12. This box is mounted on the fuselage bottom longeron below the radio mounting structure just aft of frame 16 and contains the radio supply fuses and control relays, together with a number of plugs for the radio connectors to and from the box. For further details of this box, reference should be made to Sect.6, Chap.1 of this volume.

Servicing of panels and shelves

13. The equipment panels and cabin shelves should be regularly examined to ensure that they are correctly supported, clean and undamaged. All the components should likewise be examined for security, and an examination of the wiring and terminals made for signs of damage and corrosion. The Dzus fasteners securing these panels and shelves should also be examined to ensure that they are correctly engaged and not damaged or distorted in any way, paying particular attention to the springs. Any fasteners found to be unlocked must be re-engaged and any found defective renewed as described in A.P.1464B, Vol.1, Part 2, Sect.6, Chap.3. When major servicing is necessary to these panels and shelves, it is recommended that they are removed from the aircraft and replaced with fully serviceable components, thus reducing the time in which the aircraft is unserviceable. The faulty panel or shelf should then be serviced, on the bench, and returned to store to be held as a spare. The method of removing these components is given in Group A.2 of this chapter.

Cable assemblies

14. These consist of a number of cables assembled together, most of which are fitted at each end with multi-pole plugs or sockets. The assemblies are referenced numerically, the number being prefixed with a letter denoting their location in the aircraft or, with special circuits, the service which they supply. Front fuselage cable assemblies are prefixed by the letter F, centre fuselage assemblies by the letter C and rear fuselage assemblies with the letter R. Cable assemblies in the port wing are prefixed by the letter P, while those in the starboard wing carry the letter S. The artificial horizon, GM.4F compass and armament cable assemblies are prefixed with the letters AH, GC and A respectively. The cable assemblies in the engine bay hot zones consist of Nypren insulated cables.

15. A periodical examination of the cable assemblies should be made for signs of oil soakage and to ensure that they are properly supported and not chafing, cut or damaged in any way. Damaged cables must be renewed and all slack support clips re-tightened.

Cables

16. The ends of each cable are identified, in one of two ways, by means of rubber sleeves. At equipment the sleeve gives the item and terminal to which the cable core is connected, while at terminal blocks the sleeve gives the equipment and terminal from where the cable core originated. For the type of cable employed in the various circuits, reference should be made to the routing diagrams and the table of cable abbreviations following para.37. The method of servicing and repairing the cables is contained in A.P.4343, Sect.12 and A.P.4343^{Vol.1}~~B~~, Sect. ~~4~~⁵.

Multi-pole plugs and sockets

17. Plessey standard and pressure-proof plugs and sockets, together with the Mk.4 miniature types,

are used on the cable assemblies, junction boxes and panels, etc. These are fully described in A.P.4343^C, Vol.1, Sect.24⁵, Chap.1 and 8, and consist of internal mouldings, holding the plug pins and sockets inserts, which float in fully weatherproof metal housings. The plug pin and socket inserts are each identified by a letter or number on the internal moulding and are arranged in a pattern so as to prevent incorrect assembly with their associated component, thus preventing cross-connection or short-circuiting. Those plugs and sockets fitted to cable assemblies outside junction boxes and panels etc., are provided with rubber sleeves and bungs, which seal the cable entry to prevent the ingress of moisture. The sleeves and bungs are retained in position by inner and outer ferrules locked by a coupling nut. Each socket may be identified by the cable assembly to which it is attached, the reference being printed on the rubber sleeve. Each plug is also identified by its associated cable assembly reference which is painted on the junction box or panel to which the plug is attached. Where two or more identical plugs or sockets are situated together, they are coloured for easy identification.

18. Before an attempt is made to remove a socket from its associated plug, the coupling nut, retaining the sleeve and bung assembly to the socket, must be slackened. This is necessary as the coupling nut also serves to lock the socket when it is mating with its plug. It should also be noted that this nut should be slackened before fitting the socket and the socket screwed in by hand, being assisted home by pushing on the back. A spanner or undue force must NOT be used, or damage will result.

19. The plugs and sockets should be examined periodically for signs of corrosion which, if found, must be removed without delay. The importance of cleanliness and the need for regular lubrication of the plug and socket screw threads cannot be over-emphasized if seizing of these threads is to be

avoided. ¹⁰⁰Low temperature grease XG-275 (Stores Ref. 34B/174) is to be used and all excess wiped off. On no account should a lubricant with a graphite base be employed. When it is required to examine or service the cable connections to plugs and sockets incorporating rubber sleeves and bungs, access may be gained by releasing the sleeve at the coupling nut and rolling it back until clear of the connections.

Fuses

20. The circuit fuses are contained in quick-release fuse blocks in the A.C. junction box and attached to the various panels and cabin shelves carrying the electrical equipment. They are referenced numerically, each panel and shelf having its own series of numbers. In most instances, these numbers, together with the fuse amperage and the code letters of the circuit it serves, appear on a small plate in the block adjacent to each fuse. In certain instances this information is given on a photographic label attached to the appropriate fuse block. The majority of the fuses are of the type S series, but a few Type 5 fuses are also used and reference should be made to the panel and shelf wiring diagrams for the Stores References, ratings and fuse numbers. The fuses should be examined periodically to ensure that they are serviceable and of the correct value.

Circuit breakers

21. All the circuit breakers, apart from those on and below the generator control panel and that on the gun-firing panel, which are located in the radio bay, are accessible from the cabin. They are not referenced, but may be identified by the name of the circuit that they protect, this being given adjacent to each breaker. The interior of the circuit breakers is inaccessible and servicing is therefore restricted to the functional and insulation tests given in A.P. 4343, Vol. 1, Sect. 10, Chap. 6. Table 1 lists the circuit breakers together with their ratings and Stores References.

TABLE 1

CIRCUIT BREAKERS

Circuit	Rating (amp.)	Stores Ref.
Gun-firing	5	5CY/2559
Gun sight mounting	10	5CY/2560
No.1 generator, field	10 ⁵	5CY/2560
No.2 generator, field	10 ⁵	5CY/2560
Bomb release	10	5CY/2560
D.M.E.	10	5CY/2560
Flight instrument control		
Normal	15	5CY/2561
Stand-by	15	5CY/2561
Tail plane control	25	5CY/2562
Hood control	25 OR. 15.	5CY/2562 5CY/2561 (Nov 325)
Tank pumps		
Port	25	5CY/2562
Starboard	25	5CY/2562
Engine starting	45	5CY/2564
Radar ranging	45	5CY/2564
No.1 generator, main	200	5CY/2853
No.2 generator, main	200	5CY/2853

Relays

22. The relays are located in the junction boxes and on the various panels and shelves carrying the electrical equipment. They are referenced alphabetically, the letters being given adjacent to each unit and on the wiring diagrams. The relays should be inspected at regular intervals to ensure

that the contacts are kept clean and that the units are undamaged and secure. They should also be subjected periodically to the functional tests given in A.P.4343K, Vol.1, Sect.22³, Chapters 10 to 13 inclusive.

Switchboxes

23. If signs of corrosion appear on the contacts of the switchboxes, these must be cleaned and smeared lightly with lanolin.

Terminal blocks

24. Apart from those inside junction boxes and on the panels carrying electrical equipment, terminal

blocks are also used as distribution and breakdown points throughout the aircraft. These are of the Plessey quick-release 2, 3, 5, 10 and 20-way type and are referenced numerically, the numbers being preceded by the letters T.B. Each terminal carries a coding plate on which is marked the circuit code letters, as given in the wiring diagrams. The terminal blocks may be located on the cable assembly layout and location diagrams contained in Group A.3 of this chapter.

Filament lamps

25. When renewing filament lamps, reference should be made to Table 2 to ensure that the correct type is used.

TABLE 2

FILAMENT LAMPS

Lamp	Circuit	No. off	Voltage	Wattage	Inter Service Ref.
Power failure warning	Generators and batteries	2	28	3.5	5L/X.951273
Fuel pressure warning	Fuel pressure	1	28	3.5	5L/X.951273
Cabin pressure warning	Cabin pressurization and temperature control	1	28	3.5	5L/X.951273
Alighting gear indicator	Alighting gear indicator	9	28	3.5	5L/X.951272
Alighting gear warning	Alighting gear indicator	1	28	3.5	5L/X.951273
Ultra-violet lamps	Cabin lighting	2	12	7.5	5L/X.952261
Red lamps	Cabin lighting	8 ¹	24	2.8	5L/X.951263
Red stand-by lamps	Cabin lighting	2	2.5	0.3	5L/X.951134

Lamp	Circuit	No. off	Voltage	Wattage	Inter Service Ref.
Wing-tip navigation	Navigation lamps	2	28	24	5L/X.952431
Tail navigation	Navigation lamps	1	24	10	5L/X.952276
Service lamps	Service lamps	52	24	6	5L/X.952254
Gun sight	Gun sight	4	22	12	5L/X.951260
Hydraulic pressure	Hydraulic pressure indicator	1	28	3.5	5L/X.951273
V.H.F. control	V.H.F.	2	2.5	0.5	5L/X.951122
Tele-briefing	V.H.F.	1	28	3.5	5L/X.951273
Radar locked-on	Radar ranging and supply	1	28	3.5	5L/X.951273
Fire warning	Fire warning and extinguisher	1	28	3.5	5L/X.951272
Refuelling indicator	Pressure refuelling	6	24	2.4	5L/X.952211 P.O. No. 4
TANK PUMP WARNING	TANK PUMPS	2	28	3.5	5L/X.951273

Earth points

26. Apart from the guns, engine starter, inverters, suppressors and the V.H.F. and I.F.F. radio sets, which are earthed internally or adjacent to their mountings, all the other earth leads are grouped, for ease of servicing and insulation resistance testing, and connected to the aircraft structure at a number of stud-type main earth points. All the main earth points are numbered and may be located on the cable assembly layout in Group A.3 and on the supply and earth routing chart (fig.1) of this group. When re-fitting earth leads, care must be taken to ensure that the surfaces in contact are perfectly clean and in particular, free from grease and paint. Completed assemblies should be protected against corrosion by applying one coat of blue oil-base paint to D.T.D. Spec.62B.

General servicing of system

External supply socket

27. This is mounted on the battery support structure below the batteries; access is gained by opening the radio access panel in the port radio access panel or on later aircraft, by removing a connect an external supply to the aircraft, by means of a standard plug and it is most important that, when servicing, the external supply is used to prevent the aircraft batteries from being discharged. When the external supply is in use, the generators are automatically isolated to prevent a reverse feed (Group B.1) and it is recommended that the battery master switch, located on the leg panel, is placed in the OFF position to prevent discharge of the aircraft batteries should the external supply voltage fall below that of the batteries.

Rendering aircraft electrically safe

28. When not required for flight, and during any servicing operations not requiring the electrical supply, the aircraft must be rendered electrically safe to eliminate the possibility of a short-circuit resulting in the accidental operation of the guns, hydraulic units, etc., with consequent damage to the aircraft or injury to personnel. When electrical power is required, during servicing, an external supply should be used. To render safe, it is recommended that the leads from the batteries be disconnected and stowed on the adjacent dummy terminals, as operation of the battery master switch will not render the system completely safe. Also ensure that the external supply is disconnected.

Use of spare cables for emergency servicing

29. A routing diagram of the available spare cables incorporated in the cable assemblies is given in fig.2. These are provided for future modifications and additions to the existing installation, but may also be used, in an emergency, to replace a defective cable should a circuit fail for this reason. Under this condition, having found the defective portion of cable, refer to fig.2 to find a similar cable which can be used. At suitable points, modify the existing cable run to use the spare cable and isolate the defective cable. Amend the junction box, panel and shelf wiring diagrams to agree and note the fact of this change in the aircraft log book, with the instruction that the cable assembly containing the defective cable must be changed or repaired at the next available opportunity.

NOTE....

The above procedure is only to be adopted as a palliative to keep the aircraft operational and must not be allowed to carry on indefinitely.

Insulation resistance testing

30. As an interim measure, pending the introduction of a full insulation resistance test, the following procedure, which only covers the minimum requirements should be carried out.

- (1) Remove all lamps.
- (2) Disconnect the inverters.
- (3) Disconnect earth points (1 to 19).
- (4) Remove the white compass plug from the A.C. junction box.
- (5) Remove the red and green radar plugs from the A.C. junction box.
- (6) Remove the plugs from the fire extinguishers.
- (7) Remove the supply plug to both fuel contents gauge amplifiers.
- (8) Disconnect the gun sight suppressor F.5.
- (9) Remove the voltmeter, if this has been fitted.
- (10) Remove the lamps from the Type A cut-outs.
- (11) Disconnect all other suppressors.
- (12) Remove the engine plugs.
- (13) Disconnect the Rebecca Mk.7.
- (14) Place all switches to the ON position.

- (15) Connect a 250 volt insulation resistance tester to positive terminal and to an earth point of the aircraft.

NOTE...

It is not necessary to disconnect the suppressors if an insulation resistance tester Type C, (Stores Ref. 5G/152) is in use.

Interpretation of diagrams

General

31. The wiring of all the circuits in this aircraft is shown by means of routing and theoretical diagrams. The routing diagrams show the complete wiring for each individual circuit and the physical relationship between the electrical components. The diagrams are divided into a number of columns which bear the names of the junction box and equipment panels through which the wiring passes and also the circuit code, connection pin references, and cable type, together with all break points and terminations. A plug and socket connection is shown by a small semi-circle embracing a black dot; the semi-circle denotes the socket insert and the black dot the plug pin. Terminals in the junction boxes and on equipment panels are represented by small circles with their reference numbers enclosed. Fuses are numbered and, in most instances, are shown in the equipment panel columns. These numbers refer only to the terminals and fuses in the box or on the panel concerned, each unit having its own series of numbers, as shown on the diagrams. The external connections to the equipment are shown in their correct relationship, but the internal wiring is not shown as this is given in the theoretical diagrams.

32. In the theoretical diagrams, the equipment is shown by symbols complete with internal wiring. Each symbol is annotated and designed to make the

operation of the circuit readily understandable; brief explanatory notes are also given where necessary. As the diagrams are drawn for ease of reading, the symbols are not given in their correct physical relationship, but are positioned to give a straightforward presentation, the connections being arranged to assist in this direction. The fuse rating is given adjacent to each fuse and each section of the circuit is referenced at suitable points with the circuit code. It will assist when reading theoretical and routing diagrams to refer to the cable assembly layout in Group A.3 and to note that all positive cables are given an even reference number, while all negative cables bear an odd number.

33. Unless indicated otherwise, all the routing and theoretical diagrams are drawn with the circuits in the condition found when the aircraft is at rest on the ground with its alighting gear down, the throttle closed, the engine stopped and electrical power off.

Method of reading a theoretical diagram

34. Reading theoretical diagrams is a straightforward matter if a start is made at the fuse or circuit breaker, given at the top of each circuit, and the diagram followed through to the earth point at the bottom. As an example, take the pressure head heater circuit given in Group F.2. From the 10-amp. fuse, the positive supply, referenced P.2, is taken to the control switch, which is a single-pole switch marked OFF and ON. From the switch, the positive supply cable, referenced P.4, passes to the heater element in the pressure head. The negative return from the heater, which is referenced P.1, is connected to earth.

35. From the above example and a study of the diagram, it will be seen that, when the switch is closed, the heater element will be supplied with

current and thus heat the pressure head.

Method of reading a routing chart

36. Routing charts are divided into a number of columns as previously described, and all circuits commence from the fuse or circuit breaker shown in one of the shelf, panel, or termination columns. As an example of how to read a routing chart, take the pressure head heater circuit in Group F.2. From fuse number 5, on the leg panel, the positive supply is conducted by a unipren 12 cable, referenced P.2, to terminal 2 of the pressure head switch, which is also mounted on this panel. From terminal 1 of the switch, a further unipren 12 cable, referenced P.4, connects with pin Q of plug F17, which is mounted on the leg panel. Cable assembly F17 mates with this plug and a further unipren 12 cable, also referenced P.4 and connected to pin Q of the socket, continues the supply to pin R of a plug and socket break at a frame 14. After this break, the cable assembly number changes to F18 and the unipren 12 cable, still referenced P.4, is connected to pin R and continues to another plug and socket break at frame 19. At this point, the cable assembly number changes to C18 and the unipren 12 cable, still referenced P.4 continues to pin R of plug C18 attached to J.B.1. The cable passes through the junction box and leaves it, still referenced P.4, via pin H of plug C7, which is also attached to the box. Cable assembly C7 mates with this plug and runs to the port wing plug and socket break. After this break, the cable assembly number changes to P.1 and the unipren 12 cable, still referenced P.4, is connected to pin H of the socket on this cable assembly and continues to terminal 2 of T.B.22 in the port wing-tip. From this terminal the red core of the pressure head heater cable continues the supply to the heater element. The negative return from the heater is the blue core. It is connected to terminal 1 of T.B.22 and a unipren 12 cable, referenced P.1, from the terminal block enters cable assembly P.1 and is

connected to pin G of the plug and socket break in the port wing. After this break, the cable assembly number changes to C7 and the cable, still referenced P.1, is connected to pin G of the plug on this cable assembly and runs to J.B.1, where it is connected to pin G of plug C7 attached to the junction box. From the plug a further length of unipren 12 cable connects with earth terminal 3 in J.B.1.

Cable abbreviations

37. The following table should be used in conjunction with the cable type and size column on the routing charts to define the type of cable employed in the various circuits of this aircraft.

TABLE 3
CABLE ABBREVIATIONS

Abbreviation	Definition
U/P	Unipren
D/P	Dupren
T/P	Tripren
D/P SHEATH	Duprensheath
T/P SHEATH	Triprensheath
Q/P SHEATH	Quinprensheath
U/PM	Uniprenmet
D/PM	Duprenmet
T/PM	Triprenmet
U/NYP	Uninypren
U/FIRE	Unifire
D/CS	Ducralsil
D/CV	Ducralvin

Loading chart and circuit index

38. This chart (fig.3) contains the loading for each circuit and remarks giving the duration of load, together with the total power available. An analysis of the maximum load and the power used during the duration of flight is also given. The chart may also be used as a circuit index as it gives the circuit titles and codes.

Junction box, panel, and shelf wiring diagrams

39. To facilitate servicing, each junction box, equipment panel, and shelf of this aircraft contains a diagram of its electrical wiring. These diagrams give the cable size, terminal numbers and plug references, together with the fuse numbers, ratings and Stores References. Copies of the diagrams will be found in fig.4 to 19 inclusive at the end of this group.

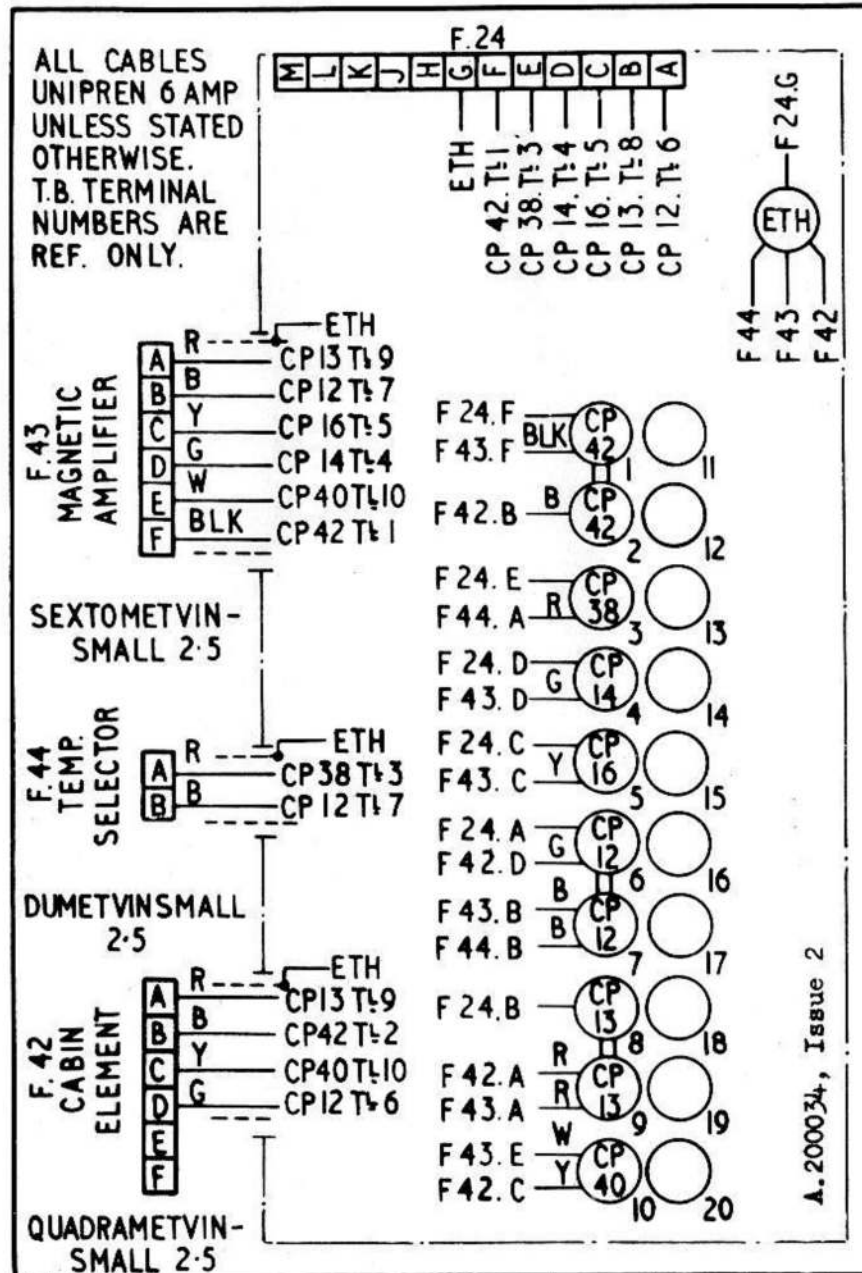

FIG. 5 WIRING OF J.B.2.

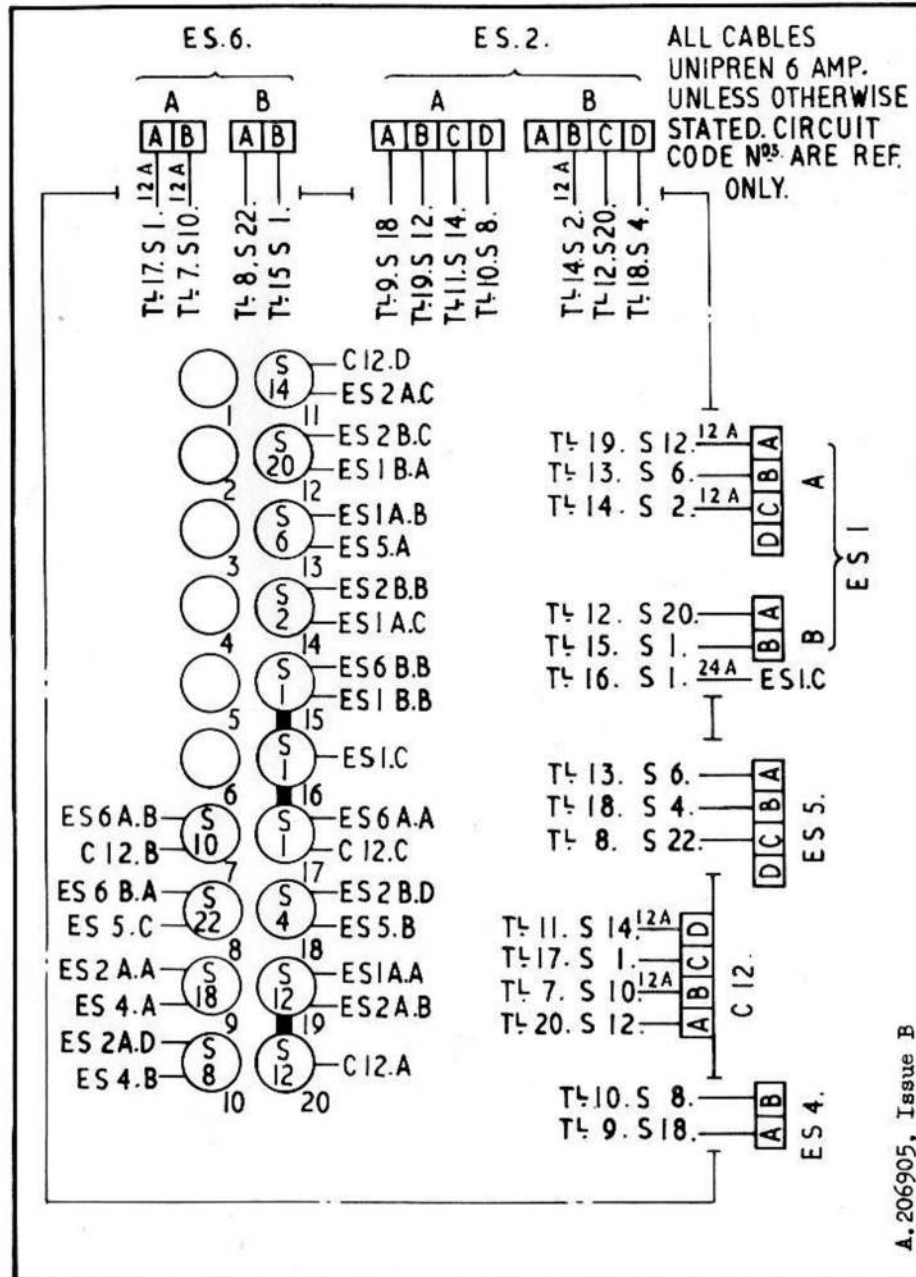

FIG. 6 WIRING OF J.B.3.

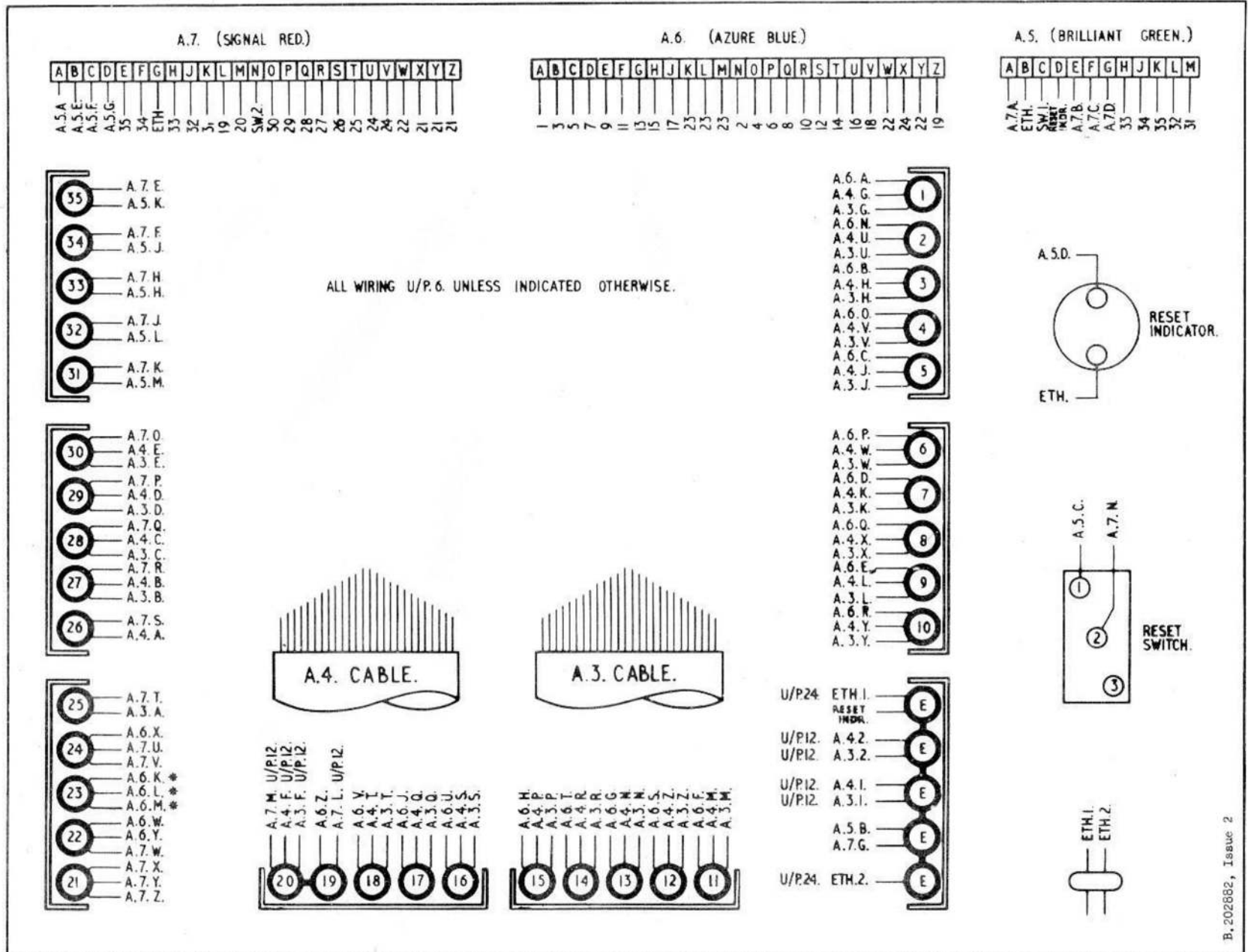
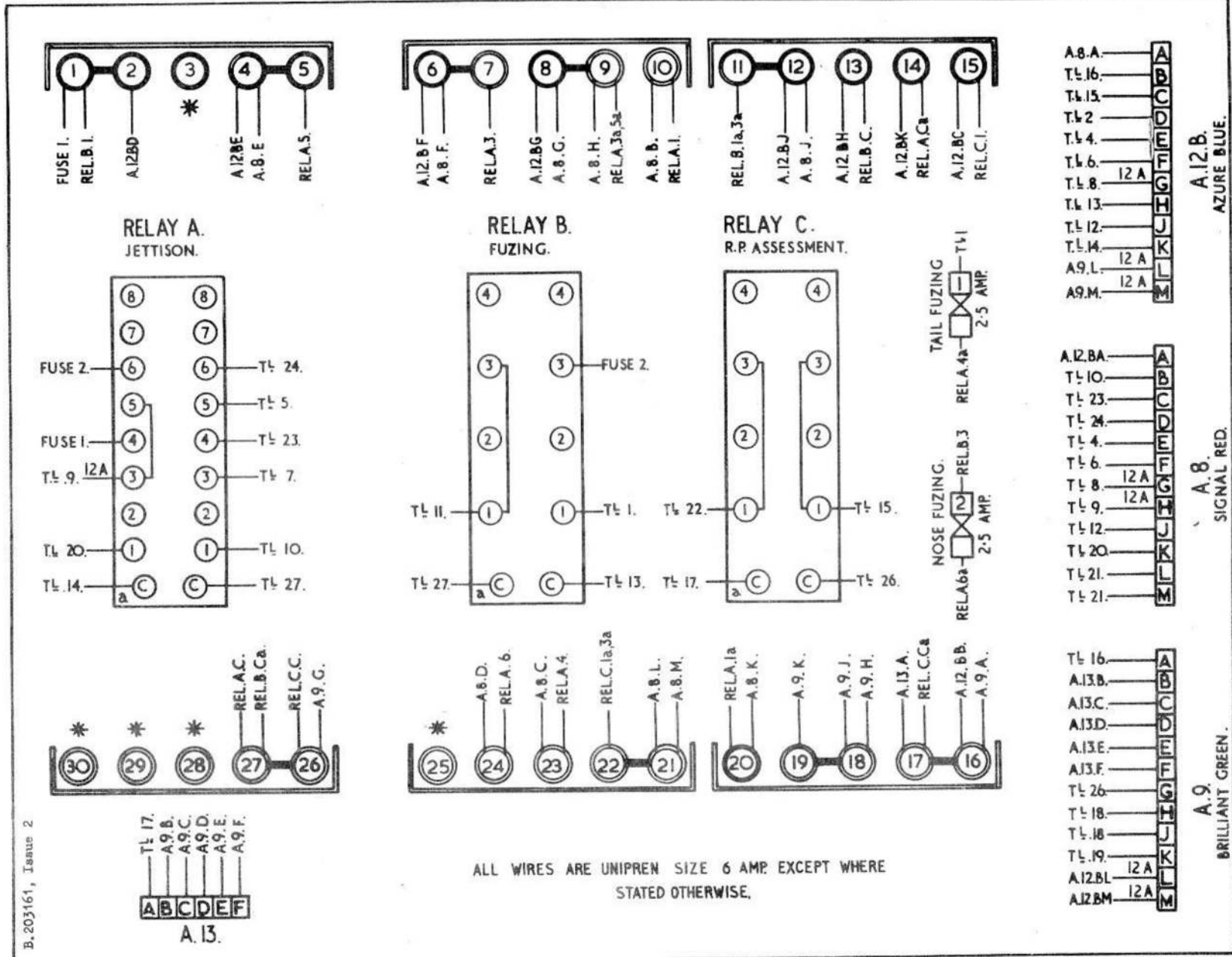
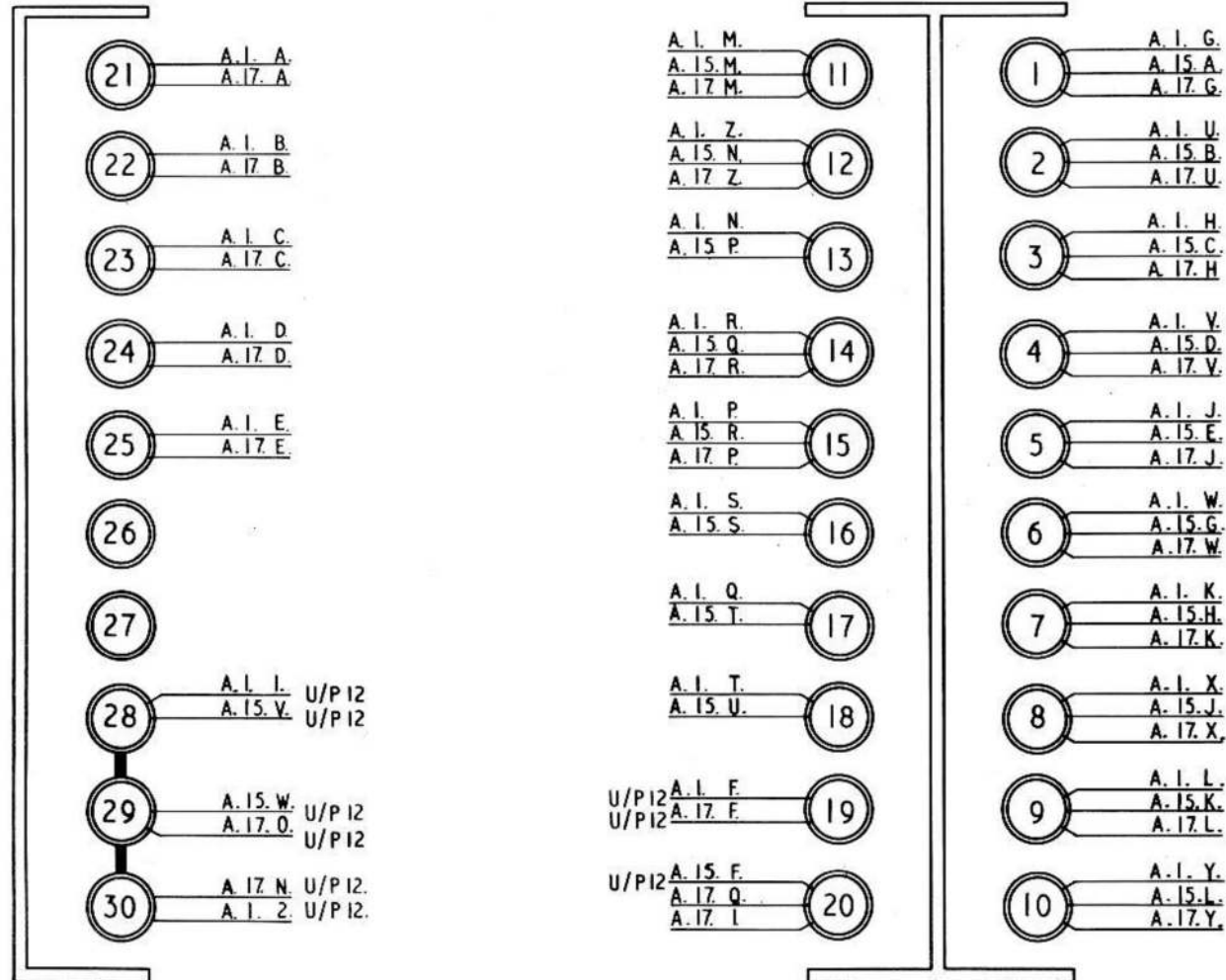

FIG. 14 WIRING OF ARM J.B.I.



B.203161, Issue 2

FIG. 15 WIRING OF ARM J.B.2.



ALL WIRING U/P 6 UNLESS INDICATED OTHERWISE.

B.208851, Issue 4

FIG. 16 WIRING OF ARM J.B.3.

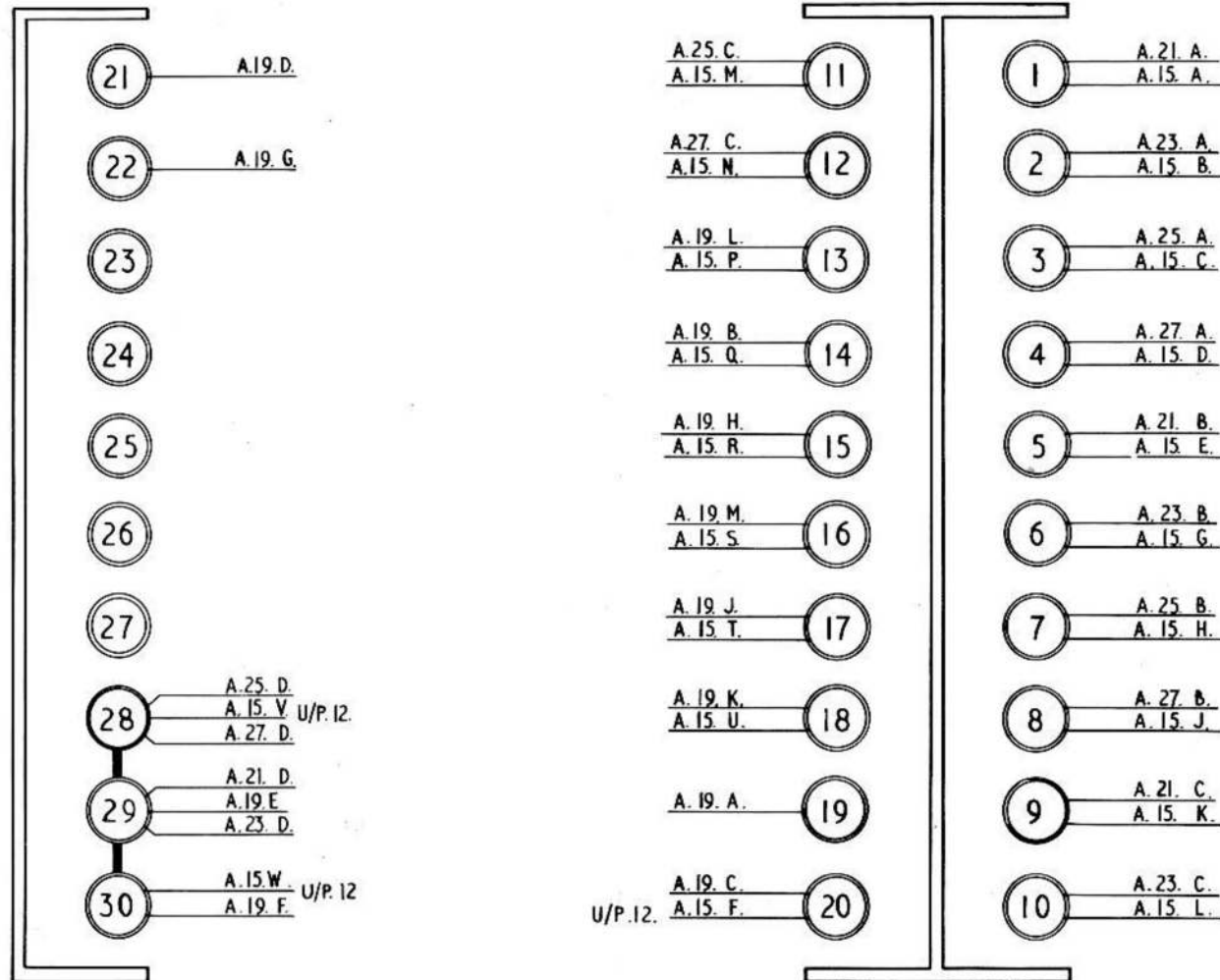

ALL WIRING U/P. 6. UNLESS INDICATED OTHERWISE.

B. 208926, Issue B

FIG. 17 WIRING OF ARM J.B.4.

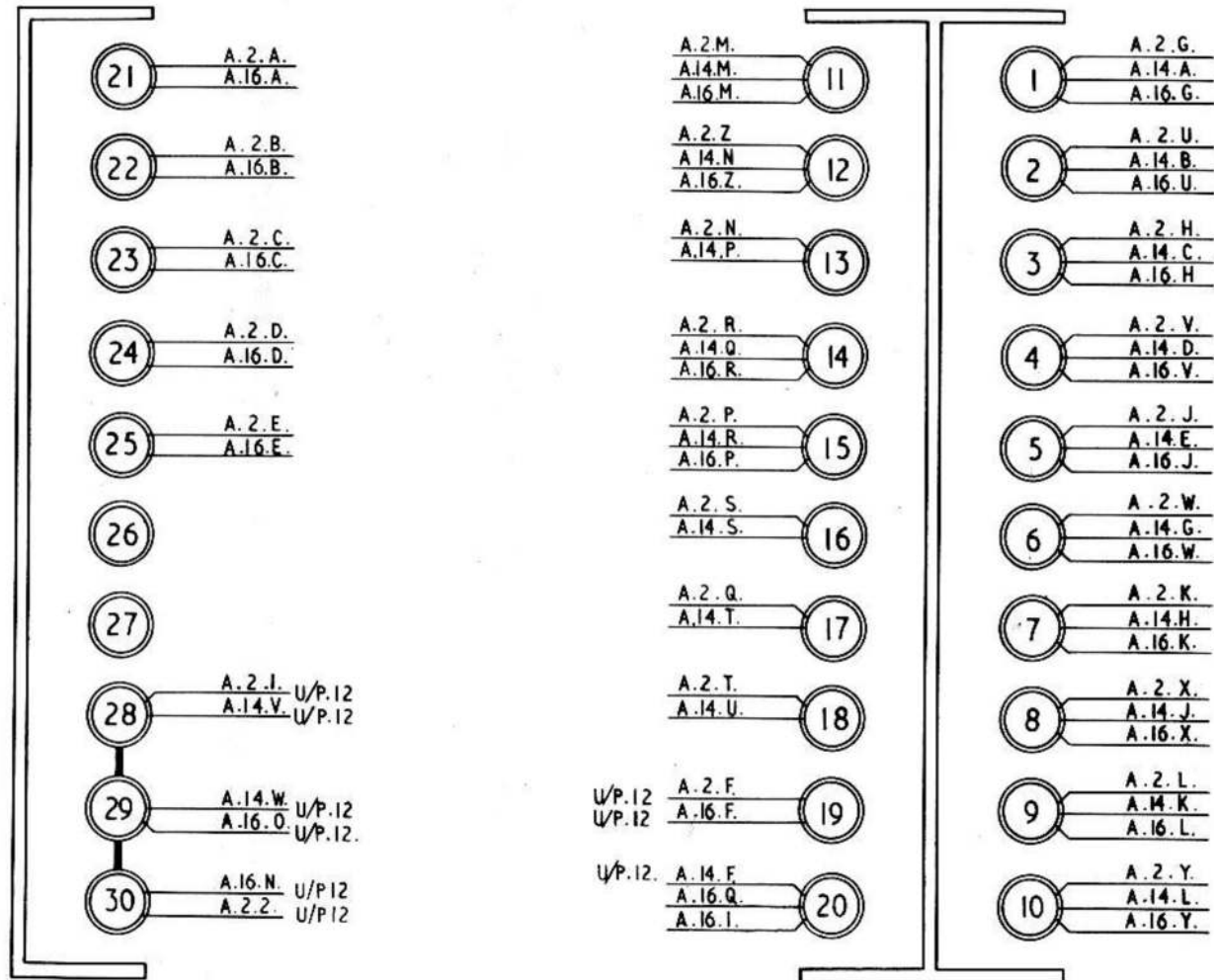

ALL WIRING U/P.6 UNLESS INDICATED OTHERWISE.

FIG. 18 WIRING OF ARM J.B.5.

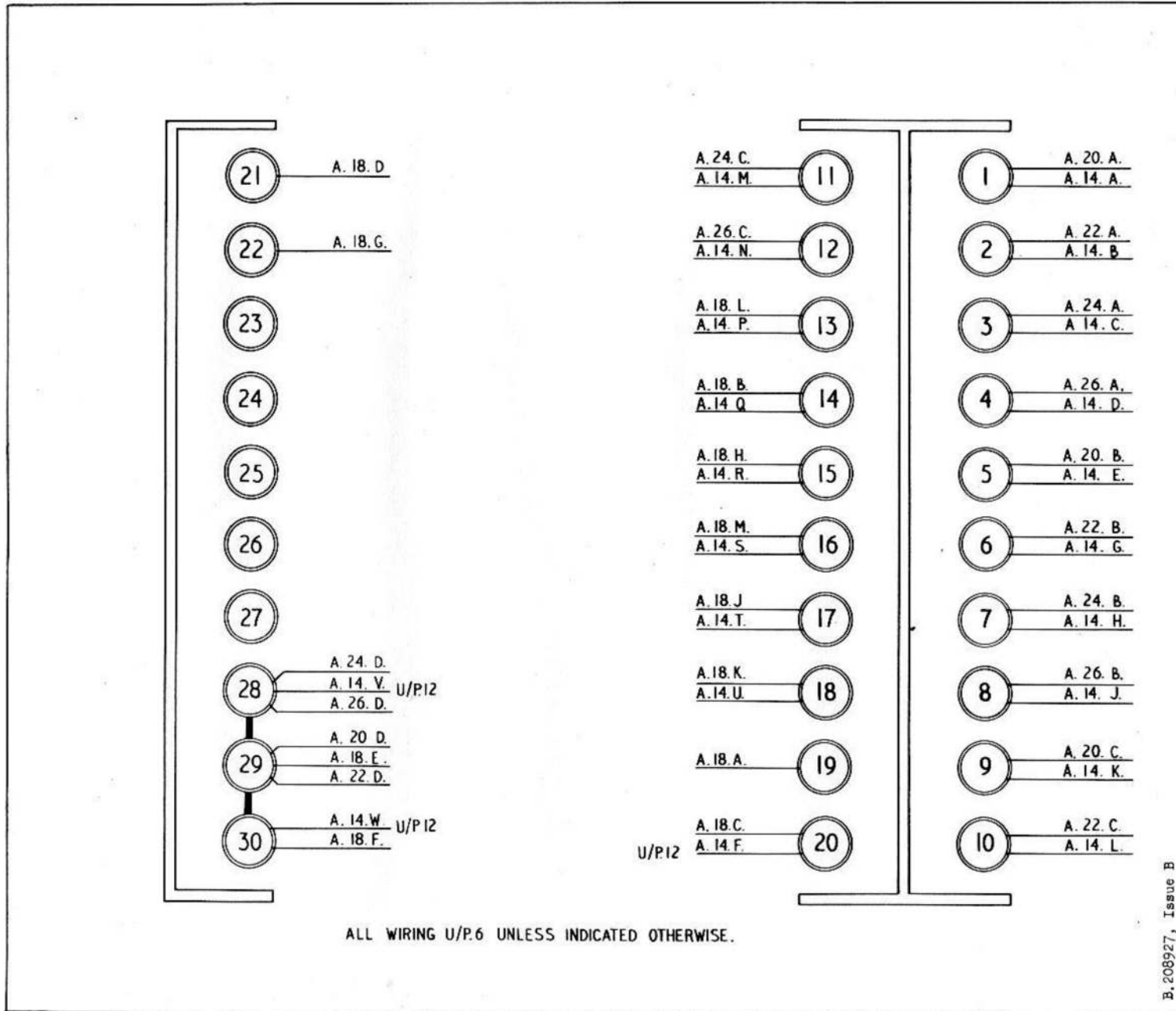

FIG. 19 WIRING OF ARM J.B.6.

This file was downloaded
from the RTFM Library.

Link: www.scottbouch.com/rtfm

Please see site for usage terms,
and more aircraft documents.

