

GROUP A.2

REMOVAL OF JUNCTION BOXES, PANELS AND SHELVES

LIST OF CONTENTS

	<u>Para.</u>		<u>Para.</u>
Introduction	1	Supply panel	13
REMOVAL			
Engine removal disconnection points	2	Generator control panel	14
Junction box 1	3	Leg panel... ..	15
Junction box 2	4	Cabin port shelf (forward portion).. ..	16
Junction box 3	5	Cabin port shelf (rear portion)	17
A.C. junction box	6	Cabin starboard shelf... ..	18
ARM junction box 1	7	Gun-firing panel	19
ARM junction box 2	8	Cable assemblies	20
ARM junction boxes 3 and 5	9	ASSEMBLY	
ARM junction boxes 4 and 6	10	General	21
Air brake relay box	11		
Bomb and R.P. control panel	12		

LIST OF ILLUSTRATIONS

	<u>Fig.</u>
J.B.1 lower attachments and earth point	1
Generator control panel upper attachment	2
Earth point 3	3
Plug at forward end of starboard shelf	4

Introduction

1. The majority of the junction boxes, equipment panels and parts of the cabin shelves are designed for quick removal to facilitate servicing. This group describes, with illustrations where necessary, the recommended methods of removing these units.

The electrical disconnections required prior to engine removal are also included. For the location of all access doors quoted in this group, reference should be made to Section 2, Chapter 4 of this publication.

RESTRICTED

REMOVAL

Engine removal disconnection points

2. The full procedure for removing the engine is contained in Section 4, Chapter 1 of this publication. The electrical disconnections necessary when carrying out this operation, are repeated, however, in this Group for the guidance of electrical servicing personnel:-

- (1) Prior to preparing to remove the engine, render the aircraft electrically safe, as described in Group A.1 of this chapter.
- (2) To remove the engine, it is first necessary to break-down the aircraft at the rear transport joint. The action necessary to break-down the electrical system at this point, consists of disconnecting cable assemblies C10, C11, C12 and the V.H.F. tele-briefing connector TS4 from their associated cable assemblies R1, R2, R3 and TS5. All these connections are located at the bottom of the fuselage between the transport joint frames and access may be gained after removal of the transport joint butt-strap. It is also necessary to disconnect the I.F.F. aerial connector at its breakdown connection, located in the spine member, adjacent to the transport joint. The electrical cables of the port and starboard rear fuel tank units should also be broken at the connectors, located on each side of the transport joint. Also, disconnect the exhaust gas thermometer cables from the terminal blocks located on frame 40B, port and starboard.
- (3) The action necessary to break-down the electrical services to the engine

consist of disconnecting cable assemblies C3 and C6 from the plugs mounted on the bottom starboard side of the engine compressor, access being obtained via the engine access door located just forward of the transport joint.

- (4) It is also necessary to disconnect the H.T. leads from the ignitor plugs on the engine. These are mounted on number 3 and 6 combustion chambers and access to them is obtained via the doors located one on each side of the centre fuselage, just forward of the transport joint.

NOTE..

Extreme care must be taken to ensure that the insulators of the H.T. leads are not cracked or damaged in any way and action must be taken to protect these parts while the engine is being removed. It is also essential to seal the end connections of the H.T. leads and ignitor plugs to prevent the entry of dirt or other foreign matter.

- (5) If it is required to remove the jet pipe from the rear fuselage, the additional action necessary to break-down the electrical services consists of removing the four thermocouples from the jet pipe. Access to these may be gained by removing the fuselage tail cone.

NOTE..

All bared ends of electrical cables must be insulated from each other and from the airframe by binding them with insulating tape. All disconnected

plugs and sockets should be fitted with approved caps and covers to prevent the entry of foreign matter. Any bonding strips removed must be retained, with the airframe, in readiness for re-fitting when the engine is re-installed.

Junction box 1

3. This junction box is mounted on the rear face of the main spar in the centre fuselage and access to it may be obtained via the engine starter access door in the undersurface of the centre fuselage. The recommended procedure for removing this box is as follows:-

- (1) Render the aircraft electrically safe, as described in Group A.1 of this chapter.
- (2) Open the engine starter access door.
- (3) Disconnect the earth lead EA9 from earth point 9 located adjacent to the lower right hand corner of J.B.1. (fig.1).
- (4) Disconnect all the plugs and sockets on the cable assemblies at J.B.1. Seal off the plugs and sockets with approved caps and covers and stow the cable assemblies away from the box.
- (5) Release the two Dzus fasteners at the lower corners of the box (fig.1) and lift the box upwards to disengage the two top mountings.
- (6) Lower the box and remove it from the aircraft, complete with earth lead EA9.

Junction box 2

4. This junction box is mounted in the cabin above the aft portion of the port shelf. To remove it, proceed as follows:-

- (1) Render the aircraft electrically safe, as described in Group A.1 of this chapter.
- (2) Disconnect cable assembly F24 from the plug on the rear end of the box. Seal off the plug and socket with an approved cap and cover.
- (3) Remove the lid of the box and disconnect all the leads of cable assemblies F42, F43 and F44 from the terminals in the box. Withdraw the cable assemblies through the grommets, insulate the cable ends and stow.
- (4) Release the box from its mountings by removing the two bolts, located one at each end inside the box, taking care to retain the distance tubes. Replace the lid on the box.
- (5) If it is required to remove the box, complete with cable assemblies F42, F43 and F44, ignore operation (3) and disconnect these assemblies at their termination, i.e. cabin element, magnetic amplifier and temperature selector. The cable assemblies may then be coiled back to J.B.2 and the box removed, as in operation (4).

NOTE...

To accomplish this operation, it will be necessary to remove the two portions of the cabin port shelf, as described in para.16 and 17 to gain access. Any straps retaining the cable assemblies must also be disengaged.

Junction box 3

5. This junction box is mounted on the gearbox access door on the underside of the centre fuselage. The recommended procedure for removing this box is as follows:-

- (1) Render the aircraft electrically safe, as described in Group A.1 of this chapter.
- (2) Unfasten the gearbox access door and allow it to swing open on its hinge.
- (3) Disconnect the plug and socket of cable C12 on junction box 3. Remove the lid to disconnect cables ES.1, ES.2, ES.4, ES.5 and ES.6 from the terminals and remove these cables with their grommets, from the box.
- (4) Remove the four bolts retaining the box to the door and withdraw the box from the aircraft. Replace the lid.
- (5) If it is required to remove this box complete with cables ES.1, ES.2, ES.4, ES.5, and ES.6, ignore operation (3) and disconnect these cables from the various starter components, access to which may be gained through the engine starter access door.

A.C. junction box

6. This box is mounted in the cabin on the starboard side between frames 12 and 13 just aft of the cabin shelf. The recommended method of removing the box is as follows:-

- (1) Render the aircraft electrically safe, as described in Group A.1 of this chapter.

- (2) Disconnect cable assemblies AC1, AC2, AC3 and AC4 from the two inverters, located below the A.C. junction box, unclip these cables and coil them back to the junction box.
- (3) Disconnect all the cable assemblies at the plugs and sockets at the junction box. Seal off the plugs and sockets with approved caps and covers and stow the cables away from the box.
- (4) Disconnect the A.C. earth lead from earth point 1 located on the side wall of the starboard shelf at the rear end.
- (5) Release the junction box from the airframe by removing the four mounting bolts and withdraw it from the aircraft, complete with the earth lead and the four inverter leads.

ARM junction box 1

7. This junction box is mounted on the fuel tank access door on the forward face of frame 19 above the battery platform and access to it may be obtained via the radio access door in the undersurface of the fuselage. The recommended procedure for removing the box is as follows:-

- (1) Render the aircraft electrically safe, as desired in Group A.1 of this chapter.
- (2) Remove the radio access door.
- (3) Remove the lid of the box and disconnect all the leads of cable assemblies A.3 and A.4 from the terminals in the box. Withdraw the cable assemblies through the ferrules, insulate the cable ends, and stow. Replace the lid on the box.

RESTRICTED

- (4) Disconnect cable assembly A.7 from the top of the box, seal off the plug and socket with an approved cap and cover and stow the cable assembly clear of the box.
- (5) Disconnect the ARM earth cable from the earth studs below the box.
- (6) Release the box from its mounting by removing the two bolts, located one at each end of the box.
- (7) The box may now be removed from the aircraft, complete with the ARM earth lead.

ARM junction box 2

8. This junction box is mounted in the cabin, on the port side, between frames 12 and 13 just aft of the cabin shelf. The recommended method of removing the box is as follows:-

- (1) Render the aircraft electrically safe, as described in Group A.1 of this chapter.
- (2) Disconnect all the cable assemblies at the plugs and sockets on the junction box. Seal off the plugs and sockets with approved caps and covers and stow the cables away from the box.
- (3) Release the box from its mounting by removing the two bolts, located at each end of the box.

Arm junction boxes 3 and 5

9. These two junction boxes, ARM J.B.3 (port) and ARM J.B.5 (starboard), are positioned in the wheel-bays, forward of the undercarriage girder and

just inboard of the undercarriage pivot castings. The recommended procedure for the removal of either of these boxes is as follows:-

- (1) Render the aircraft electrically safe, as described in Group A.1 of this chapter.
- (2) Gain access through the wheel bay.
- (3) Remove the junction box cover by releasing the four screws.
- (4) Disconnect all the leads from the terminal blocks, insulate the ends, and stow.
- (5) Unscrew the four pillars holding the terminal blocks to the platform. Remove the terminal blocks from the wheel bay.

The platform is riveted to the upper skin of the wing and is, therefore, not readily removable.

ARM junction boxes 4 and 6

10. These two junction boxes ARM J.B.4 (port) and ARM J.B.6 (starboard), are positioned one in each outer wing. Access to ARM J.B.4 is through the VHF aerial access door. Access to J.B.6 may be gained through a door in a position corresponding to that of the VHF aerial access door, though on the starboard side of the aircraft. The recommended method of removing either of these boxes is as follows:-

- (1) Render the aircraft electrically safe, as described in Group A.1 of this chapter.
- (2) Release the appropriate access door.
- (3) Remove the junction box cover which is retained by four screws.
- (4) Disconnect all the leads from the terminal

blocks, insulate the ends, and stow.

- (5) Unscrew the four pillars holding the terminal blocks to the platform. Remove the blocks through the access door.

The platform is riveted to the upper skin of the wing and is, therefore, not readily removable.

Air brake relay box

11. This box is mounted on the port side of the cabin, just aft of the hood control switchbox. To remove it, proceed as follows:-

- (1) Render the aircraft electrically safe, as described in Group A.1 of this chapter.
- (2) Disconnect the plug and socket of cable assembly F70. Seal off the plug and socket with an approved cap and cover.
- (3) Unscrew the two bolts which attach the box to the side of the fuselage.
- (4) Remove the box from the aircraft.

Bomb and R.P. control panel

12. This control panel is mounted in the cabin, to the rear of the throttle control, on the fixed portion of the cabin port shelf. The recommended procedure for removing the panel is as follows:-

- (1) Render the aircraft electrically safe, as described in Group A.1 of this chapter.
- (2) Release the control panel from its mountings by removing the two screws and raise the panel to gain access to cable assembly A.12.
- (3) Disconnect all the leads of cable assembly A.12 from the equipment on the panel.

- (4) The panel may now be removed by releasing the clip securing cable assembly A.12 to the side of the panel.
- (5) After removing the panel, insulate all the cable ends of cable assembly A.12 and stow.
- (6) If it is required to remove the panel complete with cable assembly A.12, ignore operations (3) and (4) and disconnect cable assembly A.12 at the plug and socket break on the instrument panel mountings, at the gyro gun sight suppressor and at ARM junction box 2. The cable assembly may now be coiled back to the panel after releasing the necessary straps and clips.

NOTE...

To accomplish this operation, it will be necessary to remove the two portions of the cabin port shelf, as described in para. 16 and 17 to gain access to the cable assembly.

Supply panel

13. This panel is mounted in the radio bay on the starboard side between frames 16 and 19, and access to it may be gained via the radio access door in the undersurface of the front fuselage. The panel is located behind the generator control panel and this latter panel must be removed first, or hinged up out of the way, before the supply panel can be removed. The recommended procedure for removing the supply panel is as follows:-

- (1) Render the aircraft electrically safe, as described in Group A.1 of this chapter.

RESTRICTED

- (2) Remove the radio access door.
- (3) Disengage the four Dzus fasteners securing the generator control panel to the bottom of the supply panel, raise the control panel and retain it in this position by means of the ring and chain, provided on the radio mounting structure. Alternatively, remove the control panel, as described in para.14.
- (4) Disconnect cable assemblies C1, C2, C4, C39 and F49 at the plugs located at the top and bottom of the panel. Seal off the plugs and sockets with approved caps and covers, and stow the cable assemblies away from the panel.
- (5) Disconnect all the leads of cable assemblies IF1, IF2, IF5, C5, F2, F4, F7, F9, F21, F23, F52, F56, A7E and A10 from the terminals on the panel. Remove the straps securing these leads, insulate all bare ends, coil up the cable assemblies and stow out of the way. Disconnect the leads from the circuit breakers located below the supply panel, from the terminals on the panel. Disconnect the exhaust gas thermometer leads from the terminal block adjacent to plug and socket F49.
- (6) Disconnect the two earth leads E5A from earth point 5 on the battery mounting. Remove any straps securing this lead and coil back to the supply panel.
- (7) Disengage the panel from the aircraft structure by removing the six screws from the forward and rear edge, together with the six nuts from the studs

projecting through the panel channel members.

NOTE...

To gain access to these attachments, it may be necessary to bend the cable assemblies out of the way and ensure that they are not damaged when removing the attachments.

- (8) Withdraw the panel from the studs on the fuselage frames and remove it from the aircraft complete with earth leads E5A.

Generator control panel

14. This panel is mounted in front of the supply panel in the radio bay on the starboard side between frames 16 and 19. Access to it may be gained via the radio access door in the undersurface of the front fuselage. To remove this panel, proceed as follows:-

- (1) Render the aircraft electrically safe, as described in Group A.1 of this chapter.
- (2) Remove the radio access door.
- (3) Disconnect cable assembly F49 from the plug located at the top of the supply panel. Seal off the plug and socket with an approved cap and cover.
- (4) Disconnect cable assemblies C37, C38, F52 and C5 from the differential cut-outs and the battery relay mounted on the control panel. Remove any straps and clips securing these cable assemblies, insulate the bare cable ends and stow the assemblies away from the panel.

- (5) Disengage the four Dzus fasteners securing the bottom of the panel and, with a second person supporting the panel, withdraw the two top hinge pins by removing the split-pins and washers (fig. 2).
- (6) Lower the panel and remove it from the aircraft, complete with cable assembly F49.

Leg panel

15. The leg panel is bolted to the cabin floor, just forward of the control column and below the centre instrument panel. The recommended procedure for removing it is as follows:-

- (1) Render the aircraft electrically safe, as described in Group A.1 of this chapter.
- (2) Disconnect the Bowden cable from the rudder bar release lever at the top of the leg panel and stow it away from the panel.
- (3) Disconnect cable assembly F31 from cable assembly F64 at the plug and socket located on the starboard side of the instrument panel mounting structure. Remove any straps and clips securing the F31 cable and coil it back to the leg panel. Fit an approved cap and cover to the plug and socket.
- (4) Disconnect cable assembly A11 from cable assembly A12 at the plug and socket break, located on the port side of the instrument panel mounting structure. Remove any straps and clips securing the A11 cable and coil it back to the leg panel. Fit on approved cap and cover

to the plug and socket.

- (5) Disconnect cable assembly E3/A from earth point 3, obtaining access via the hinged door in the port side of the leg panel (fig. 3).
- (6) Disconnect all the plugs and sockets on the cable assemblies at the leg panel. Seal off the plugs and sockets with approved caps and covers and stow the cable assemblies away from the panel.
- (7) Release the leg panel from its mountings by removing the nine bolts from around the bottom forward, and side faces of the panel. Remove the leg panel from the cabin, complete with cable assemblies F31 and E3/A.

NOTE...

Although it is possible to remove the leg panel without disturbing the centre instrument panel, access is easier if this latter panel is removed first.

Cabin port shelf (forward portion)

16. This removable portion of the cabin port shelf is located just inboard of the throttle box and the recommended method of removing it is as follows:-

- (1) Render the aircraft electrically safe, as described in Group A.1 of the chapter.
- (2) Remove the fourteen screws from around the side wall, rear edge and outboard side of the top panel. Raise the shelf to obtain access to the plug and socket breaks of cable assemblies F19 and F28 and disconnect these cable assemblies.

- (3) Remove the shelf from the cabin and seal off the plugs and sockets with approved caps and covers.

Cabin port shelf (rear portion)

17. This removable portion of the cabin port shelf is located just behind the throttle control. The recommended procedure for removing the shelf is as follows:-

- (1) Render the aircraft electrically safe, as described in Group A.1 of this chapter.
- (2) Disconnect all the plugs and sockets on the cable assemblies at the end plate at the rear end of the shelf. Seal off the plugs and sockets with approved caps and covers and stow the cable assemblies away from the shelf.
- (3) Release the shelf from the fixed structure by disengaging the Dzus fasteners. Raise the shelf to obtain access to the connection of cable F44 to the temperature selector, and disconnect this cable assembly. Seal off the plug and socket with an approved cap and cover.
- (4) Remove the shelf from the cabin.

Cabin starboard shelf

18. The recommended procedure for removing this shelf is as follows:-

- (1) Render the aircraft electrically safe, as described in Group A.1 of this chapter.
- (2) Disconnect all the plugs and sockets on the cable assemblies at the end plate at the rear end of the shelf. Seal off the

plugs and sockets with approved caps and covers and stow the cable assemblies away from the shelf.

- (3) Disconnect cables assemblies F33 and F34 from the A.C. junction box, fit approved caps and covers to the plugs and sockets and coil back the cable assemblies to the starboard shelf.
- (4) Disconnect cable assembly F5 from the plug mounting bracket at the forward end of the shelf (fig.4). Seal off the plug and socket with an approved cap and cover. Stow the cable assembly clear of the shelf.
- (5) Remove the mounting frame, carrying the D.M.E. control unit from the top surface of the shelf, by unscrewing the four screws. Disconnect the radio connector from the control unit and refit the mounting frame and control unit.
- (6) Release the emergency oxygen control cable duct, from the shelf side wall, by removing the bolt securing the clip around the top of the cable duct.
- (7) Release the shelf from the fixed structure by disengaging all the Dzus fasteners around the top face and side wall. Withdraw the shelf from the cabin, complete with cable assemblies F33 and F34.

Gun firing panel

19. This panel is mounted in the radio bay, on the port side, and access may be gained via the radio access panel in the undersurface of the

front fuselage. To remove the panel, proceed as follows:-

- (1) Render the aircraft electrically safe, as described in Group A.1 of this chapter.
- (2) Remove the radio access panel.
- (3) Remove the batteries, as described in Section 2, Chapter 2 of this volume.
- (4) Remove the Type 200 inverter, located just aft of the gun firing panel, by removing the control box cover and disconnecting the two d.c. input leads from the terminal block. Replace the cover. The output from the inverter must also be disconnected at the plug on the control box, together with the air cooling pipe at the union on the commutator end cover. Release the inverter from its adaptor plate by removing the four attachments, located one at each corner.
- (5) Disconnect all the leads of cable assemblies F21, F46, F47 and F48 from the terminal blocks on the gun-firing panel. Insulate the bare ends of the leads and stow the cable assemblies away from the panel.
- (6) Release the gun-firing panel from the fixed structure by removing the four stiffnuts, and withdraw it from the aircraft via the radio access panel.

Cable assemblies

20. The majority of the cable assemblies are

supported throughout their length by a number of plastic-covered metal clips and flexible plastic straps. The method of removing these assemblies is straight forward, if reasonable care is taken, when removing the cables assemblies which pass through the ducts at the bottom of the centre fuselage, it is essential to remove the outer threaded ring from the Mk.4 sockets, by disengaging the circlip, as the sockets will not pass through the ducts with these rings in position.

ASSEMBLY

General

21. In most instances, the assembly of the units is a reversal of the removal procedure, but where there is any special assembly feature this is covered by a note in the appropriate paragraph of this group.

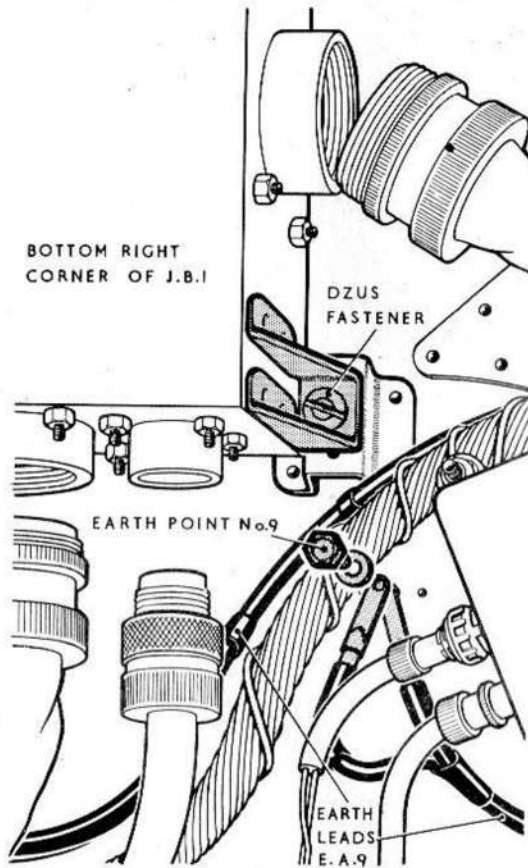

FIG.1 J.B.I LOWER ATTACHMENTS AND EARTH POINT No.9

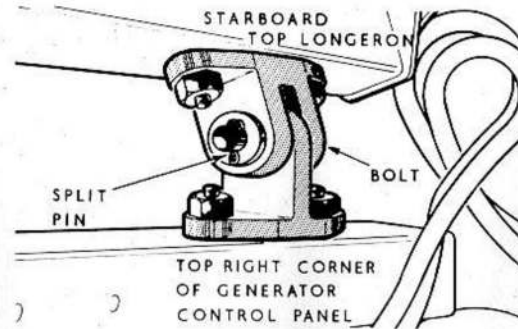

FIG.2 GENERATOR CONTROL PANEL UPPER ATTACHMENTS

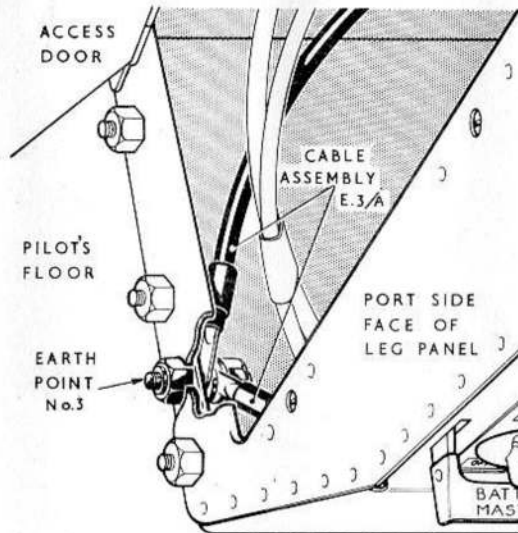

FIG.3 EARTH POINT No.3

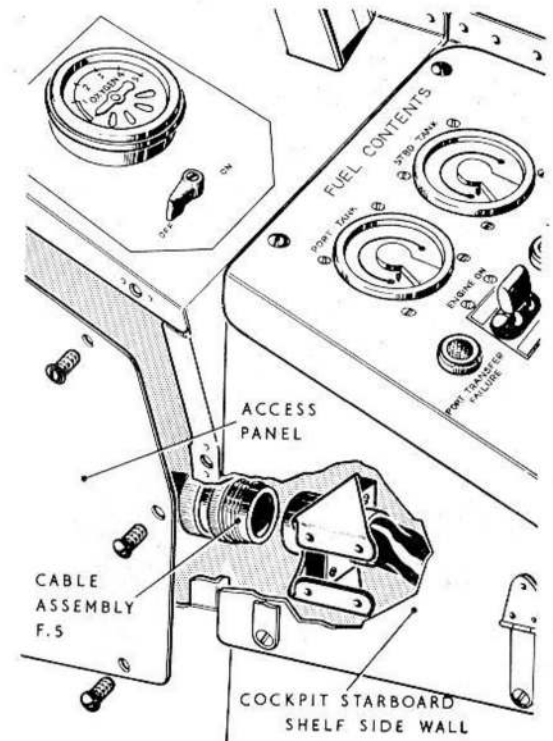

FIG.4 PLUG AT FORWARD END OF COCKPIT STARBOARD SHELF



This file was downloaded
from the RTFM Library.

Link: www.scottbouch.com/rtfm

Please see site for usage terms,
and more aircraft documents.