

GROUP F.1

CABIN LIGHTING (CODE M)

LIST OF CONTENTS

	<u>Para.</u>		<u>Para.</u>
Equipment employed ... ..	1	<b>SERVICING</b>	
<b>DESCRIPTION</b>		General ... ..	8
Cabin lighting		<b>REMOVAL AND ASSEMBLY</b>	
General ... ..	2	General ... ..	9
Ultra-violet lamps ... ..	3		
Instrument panel red lamps ... ..	4	<b>ILLUSTRATION</b>	
Cabin shelf red lamps ... ..	5	Cabin lighting ... ..	<u>Fig</u> 1
Stand-by lamps ... ..	6		
Operation ... ..	7		

Equipment employed

1. The major components employed in the cabin lighting circuit are quoted below, together with the appropriate Air Publications to which reference

should be made for a detailed description and the necessary servicing required to maintain them in an efficient condition.

Dimmer switches, Type R, 22 and 75 ohm ... ..	A.P.4343B, Vol.1, Sect.20, Chap.16
Switch, Rotax D.5404/1 ... ..	A.P.4343C, Vol.1, Sect. 1, Chap.28
Cabin lamps, Type C. No.2 ... ..	A.P.4343E, Vol.1, Sect. 7, Chap.17
Ultra-violet lamps, Type B, No.1 .. ..	A.P.4343E, Vol.1, Sect. 7, Chap.21
Battery, 2.4 volt, 1.2 amp. .. ..	A.P.1095C, Vol.1, Sect. 1, Chap. 5

## DESCRIPTION

### Cabin lighting

#### General

2. The cabin lighting installation consists of four separately controlled circuits supplying lamps to illuminate the instrument panels and cabin shelves. The following paragraphs describe each of these circuits in turn. Routing and theoretical diagrams of the circuits are given in fig.1.

#### Ultra-violet lamps

3. Two ultra-violet lamps, connected in series and controlled by a dimmer switch are positioned one on each side of the cabin, just forward of frame 10 and below the light deflector screens, so that their beams fall on the fluorescent instruments on the instrument panels. The dimmer switch is mounted at the top of a bracket attached to the fuselage skin above the cabin starboard shelf, just forward of frame 10.

#### Instrument panel red lamps

4. Five red lamps, connected in parallel are positioned, two on each side of the cabin just forward of the ultra-violet lamps and one on the starboard forward face of frame 10, to illuminate the instrument panels. These lamps are switched on and dimmed, as required, by a dimmer switch mounted below the ultra-violet lamps switch on the starboard side of the cabin.

#### Cabin shelf red lamps

5. Another four red lamps, also connected in parallel, are located two on each side of the cabin on frames 10 and 11, to illuminate the cabin shelves. These lamps are switched on and dimmed, as required, by a dimmer switch mounted below the instrument panel red lamps switch.

#### Stand-by lamps

6. Should the normal cabin lighting fail, two red stand-by lamps may be brought into operation. These lamps are mounted one on each side of the cabin below the light deflector screens, adjacent to the instrument panel red lamps. The lamps are not connected to the normal electrical system, but obtain their supply from a small battery mounted in the cabin on the starboard side of frame 12. A single pole ON/OFF switch, located on frame 9 above the cabin starboard shelf, controls the installation.

#### Operation

7. The operation of the circuits should be obvious once reference is made to the theoretical diagrams, given in fig.1 of this group.

## SERVICING

#### General

8. For general servicing of the electrical system as a whole, reference should be made to Group A of this chapter, which also contains a table giving the types of filament lamps used in this circuit. Apart from keeping all the components clean and checking the filament lamps for serviceability, no further servicing should be necessary.

## REMOVAL AND ASSEMBLY

#### General

9. The removal and assembly of the components forming the cabin lighting circuit should present no unusual difficulties. The location and access to all the components is indicated in Group A of this chapter.

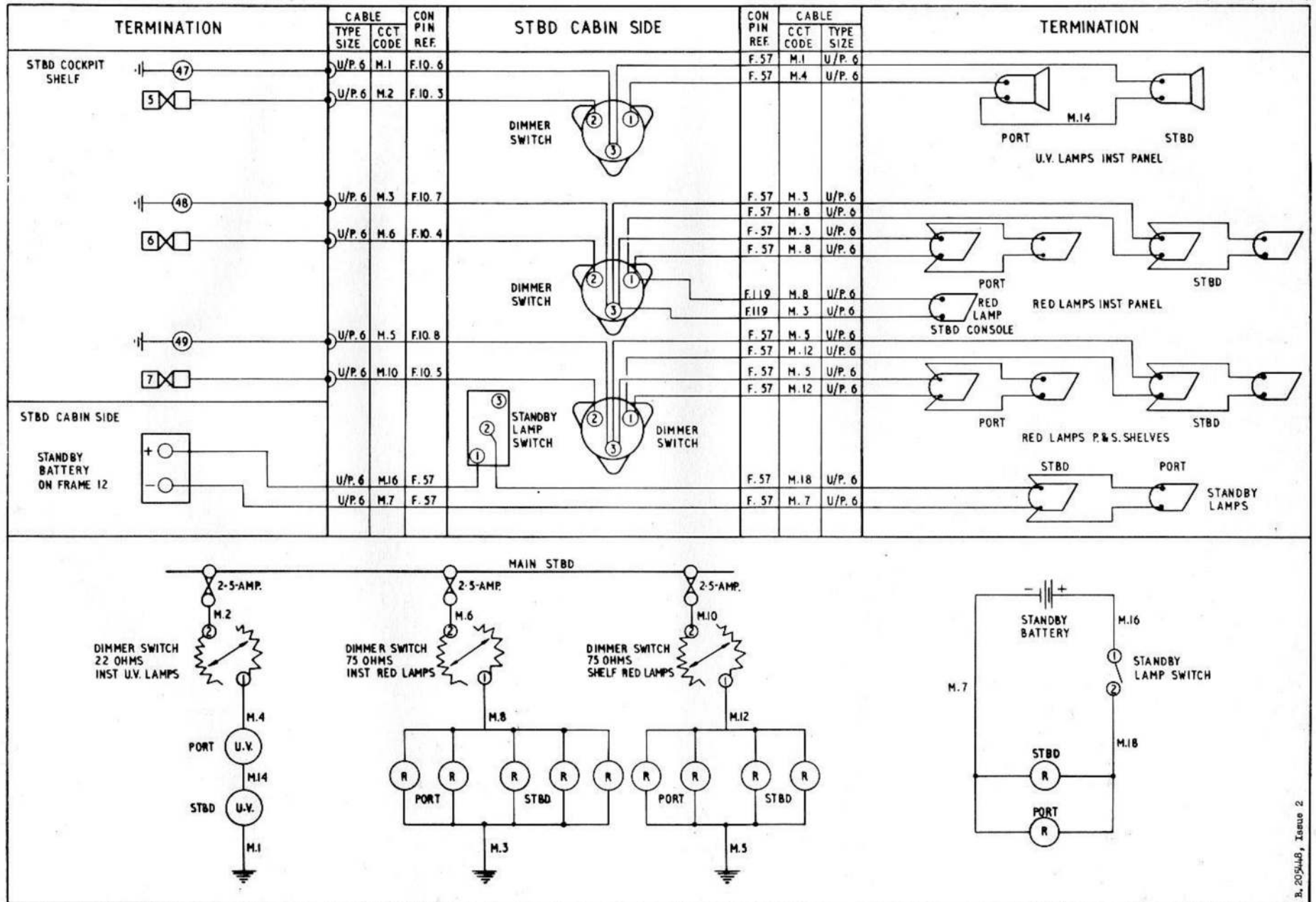
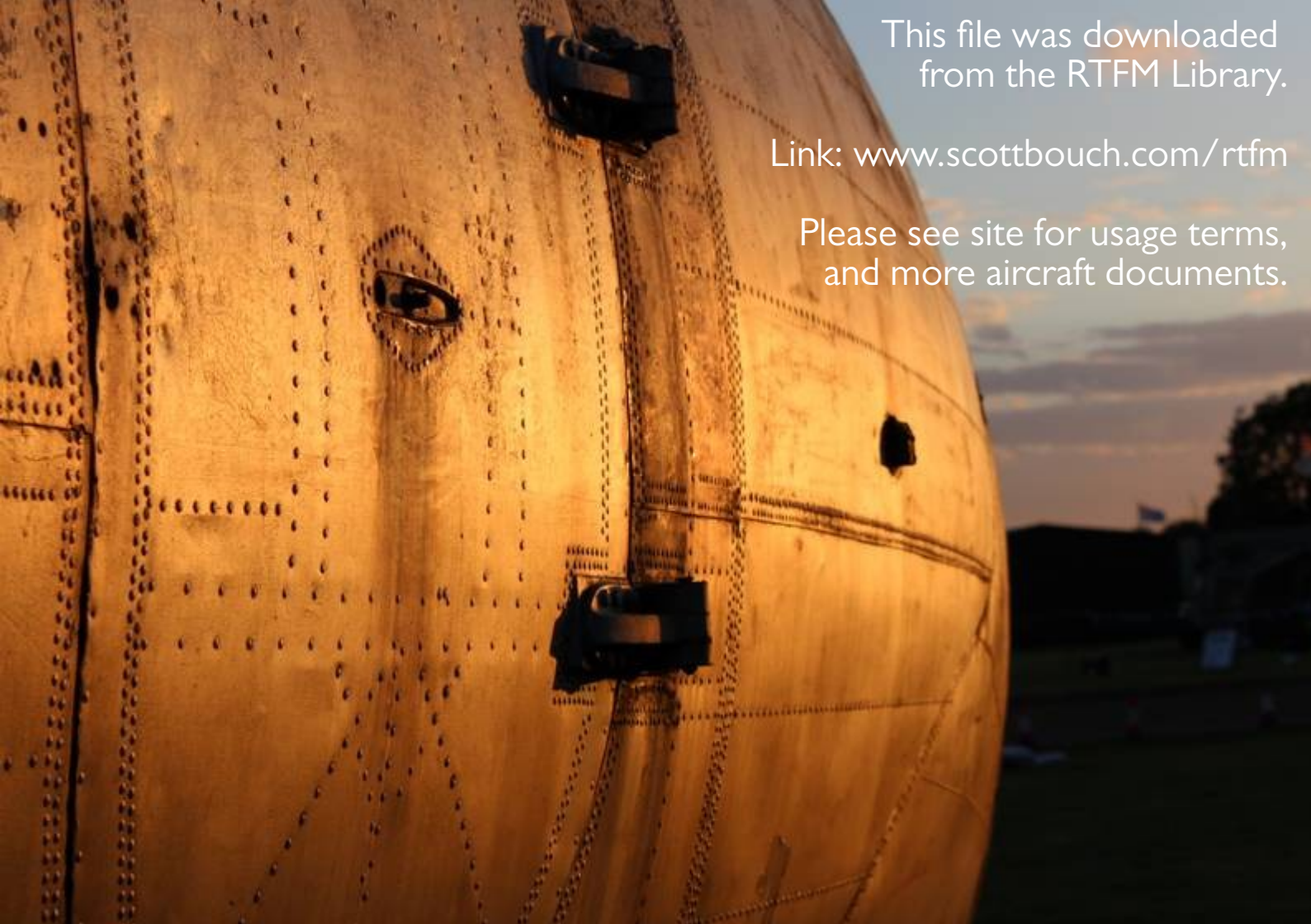

FIG. 1 CABIN LIGHTING  
RESTRICTED



This file was downloaded  
from the RTFM Library.

Link: [www.scottbouch.com/rtfm](http://www.scottbouch.com/rtfm)

Please see site for usage terms,  
and more aircraft documents.