

CHAPTER 1
WIRELESS INSTALLATION
LIST OF CONTENTS

	<u>Para.</u>		<u>Para.</u>
Introduction	1	Functional check	30
DESCRIPTION		Fault finding	31
General	2	A.R.I. 18085	
Radio bay and mounting structure	3	General	32
A.R.I. 18064	4	Security check	33
A.R.I. 18085	5	Functional check	34
A.R.I. 18012	6	Fault finding	35
Interconnection	8	A.R.I. 18012	
		General	36
		Final check	37
OPERATION		REMOVAL AND ASSEMBLY	
A.R.I. 18064	9	General	38
A.R.I. 18085	15	Transmitter-receiver 1985 and 1986	39
A.R.I. 18012	22	Type 7747 modulator unit	40
SERVICING		Type 7089 aerial junction box	41
General	24	Type 1254 relay unit	43
Power supplies	25	V.H.F. relay box	44
Cables and connectors	26	Type 228 and 229 aerials	45
Mic.-tel test socket	27	Azimuth aerials	46
A.R.I. 18064		Elevation aerial	47
General.	28	Type 382 control units	48
Security check	29	Type 7746 control unit	49
		Radio mounting structure	50

LIST OF ILLUSTRATIONS

	<u>Fig.</u>
Location (1)	1
Location (2)	2
Interconnection	3
Wiring of V.H.F. relay box	4

Introduction

1. This chapter contains a description of the wireless equipment installed in this aircraft, including the servicing information necessary to maintain the installation in an efficient condition. Information on the removal of the various components together with illustrations showing the location and interconnection of the equipment are also included. For a detailed description and technical information regarding the standard equipment used, reference should be made to the following Air Publications:-

A.R.I. 18064 A.P. 2538 HA, Vol.1.
A.R.I. 18085 A.P. 2898D, Vol.1.
A.R.I. 18012 A.P. 2876G, Vol.1.

DESCRIPTION

General

2. The wireless equipment consists of an A.R.I. 18064 twin 10-channel V.H.F. communication installation, with which is associated an A.R.I. 18085 wideband homing installation and an A.R.I. 18012 telebriefing system. A system to give the pilot audio warning of loss of hydraulic pressure is also linked with the installation. The transmitter-receivers and associated equipment are carried in the radio bay in the front fuselage, being remotely operated by control units situated in the cabin. The installation employs five whip aerials, one of which projects upwards through the top skin of each outer wing, another from below the front fuselage, while the remaining two project upwards from the centre fuselage, one on each side of the spine member. When in use, the external telebriefing cable engages with a plug located in the undersurface of the rear fuselage. The location of the wireless equipment is illustrated in fig.1 and 2.

Radio bay and mounting structure

3. The radio bay is located in the front fuselage and extends aft from frame 16 to the forward transport joint. Apart from the radio sets and their associated equipment, this bay also contains various components of the aircraft's electrical system, for example, the electrical supply panel, generator control panel and the batteries. Access to the bay may be obtained by opening the access doors, located in the undersurface of the front fuselage immediately in front of the forward transport joint. The radio mounting structure is in two main parts, each supporting anti-vibration mounting racks for the transmitter-receivers and their associated equipment. The upper structure consists of two-angle-sectioned beams with a platform carried between them. The complete assembly extends across the radio bay and is bolted to frames 17A and 17B. Another platform is attached to the starboard side of the beam bolted to frame 17B and extends aft to brackets on frame 19. The lower structure extends along the port side of the radio bay and consists of a number of square tubes, which are bolted together through gusset plates and arranged so as to form two platforms located one above the other. The forward end of the structure is in the form of a diaphragm and the complete assembly is bolted to brackets on frames 16 and 19.

A.R.I. 18064

4. The Type 1985 and 1986 transmitter-receivers are carried side by side in Type 873/2 mounting racks on the bottom platform of the lower radio mounting structure, described in para.3 of this chapter. The 1985 transmitter-receiver is known as set No.1 and is located at the aft end of the mounting, while the 1986 transmitter-receiver, known as set No.2 is located at the forward end of the structure. Each transmitter-receiver is remotely controlled by a Type 382 control unit, but a single

press-to-transmit push-switch is used for both transmitter-receivers. Only one set is employed at any given time, being selected by a set selector switch. Both remote control units and the set selector switch are situated on the cabin port shelf while the press-to-transmit push-switch is incorporated in the throttle twist grip. The supply to the sets, the mic.-tel., and press-to-transmit switching from one set to the other, is accomplished by a number of relays contained, together with the supply fuses, in a quickly detachable box, known as the V.H.F. relay box; this is mounted on the fuselage bottom longeron below the radio mounting structure just aft of frame 16. A Type 359 mic.-tel. socket for use when adjusting the sets, is stowed in a spring clip at the bottom of this relay box. The No.1 transmitter-receiver employs a Type 228 aerial, mounted on a small access panel in the upper surface of the starboard outer wing, while the No.2 transmitter-receiver uses a Type 229 aerial mounted in a similar position on the port outer wing. A Type 359 mic-tel. pull-out socket for the pilot's ejector seat connection is located on the port side of the flying control casing.

A.R.I.18085

5. A Type 7747 modulator unit for this homing installation is carried on a Type 1034 mounting tray bolted to the platform carried between the two beams of the upper radio mounting structure, described in para.3 of this chapter, while a Type 7089 aerial junction box is bolted to the platform extending from the aft member of this structure to frame 19. A type 1254 aerial relay unit is also bolted to the starboard side of the forward face of frame 19. The Type 7 homing indicator is situated on the starboard side instrument panel and the installation is remotely controlled by a Type 7746 control unit located in the cabin on the starboard side of the forward face of frame 14 and by three switches carried on a mounting plate attached to the port lighting side screen in the cabin. One switch is marked

V.H.F., NORMAL and HOME, and is provided with a spring-loaded guard, another is marked AZIM and ELEV, while the third is marked MAX. and MIN. These latter two switches are not provided with guards. The two azimuth aerials are located at the top of the centre fuselage, one each side of the spine member in the region of frame 25. Each consists of a Type 408 aerial rod, held in a plastic base attached by side plates to the inside of the fuselage skin with the aerial rod projecting upwards through a grommet fitted in a hole in the skin. The elevation aerial is located at the bottom of the front fuselage adjacent to the forward transport joint. It also consists of a Type 408 aerial rod held in a plastic base attached by brackets to the battery mounting platform structure in the radio bay. The aerial rod projects downwards through a hole in the radio access doors, being protected by a grommet where it passes through the doors.

A.R.I. 18012

6. A push-switch and indicator lamp for this tele-briefing installation are mounted on the forward end of the cabin port shelf. The external tele-briefing cable, when employed, is connected to a plug mounted on a spring-loaded door in the underside of the rear fuselage between frames 53 and 54. The control relays for this installation are also contained in the V.H.F. relay box located in the radio bay.

7. The electrical supply circuit for the radio installation and the operation of the control relays in the V.H.F. relay box are described in Group H.1 of Sect.5, Chap.1 of this volume, while information on the hydraulic pressure failure audio warning system is given in Group D.2 of the same section. The frequency range of the 1985 transmitter-receiver is from 100 to 125 Mc/s, while that of the 1986 transmitter-receiver extends from 124.5 to 156 Mc/s, thus the installation offers twenty pre-set frequency channels,

within this range, for selection by the remote control units.

Interconnection

8. The various components of the installation are interconnected as shown in fig.3 by a number of Constructor's and Ministry of Supply connectors, strapped and clipped to the aircraft structure. The connectors are of the metal-braided and non-braided type fitted with standard and miniature plugs and sockets, the metal braided connectors being bonded where necessary by the clips holding them in position. The Constructor's connectors are Unipren and Uniprenmet cables and are mainly employed in the set change-over and tele-briefing circuits, while the Ministry of Supply connectors are used for the main inter-connections and aerial feed circuits. A wiring diagram of the V.H.F. relay box is given in fig.4.

OPERATION

A.R.I. 18064

9. The setting-up and operating instructions for this installation are given in A.P.2538 HA, Vol.1, but for the guidance of servicing personnel a brief description of the operating procedure, will be found in the following paragraphs.

10. The power supply to the installation, together with the mic-tel. socket and the press-to-transmit push-switch are normally connected to set No.1 but may be transferred to set No.2 by operation of the set selector switch. As all the frequency channels are set up before flight, it is only necessary for the operator to know the relation between these frequency channels and the channel letter coding on the dials of the control units to enable him to select any one of the twenty frequency channels available.

11. With the set selector switch placed in set No.1 position, rotation of the selector switch knob of

No.1 control unit, which is the inboard of the two control units located on the cabin port shelf, from OFF to any one of the other ten positions will switch on No.1 transmitter-receiver and select the channel allocated for that particular position of the selector switch. When switched on, the transmitter-receiver is automatically in the "receive" condition thus signals on the selected channel will be heard. When it is required to transmit on the selected channel, it is necessary for the operator to depress the press-to-transmit push-switch situated in the throttle twist grip for as long as transmission is required. When the press-to-transmit push-switch is released, the transmitter-receiver will automatically return to the "receive" condition.

12. When it is required to employ set No.2, it is first necessary to place the set selector switch to set No.2 position as this operation energizes relays C, D and G in the V.H.F. relay box, which in turn transfer the power supply, mic.-tel. socket and the press-transmit push-switch from set No.1 to set No.2. Rotation of the selector switch knob of No.2 control unit from OFF to any one of the other ten positions will now switch on No.2 transmitter-receiver and select the frequency channel allocated to that position of the control unit selector switch. When switched on, this transmitter-receiver is also automatically set to "receive" and the press-to-transmit push switch must be depressed for as long as transmission is required. When the push-switch is released, the set will automatically return to the "receive" condition.

13. When the selector switch knob of the control unit for the set selected is rotated from OFF to any other position, the indicator dial will be illuminated by a lamp within the control unit. The degree of illumination may be controlled by a lamp dimmer control also situated on the control unit. In case of hydraulic pressure failure, the audio warning system, which is controlled by the hydraulic pressure

indicator circuit, as described in Group D.2 of Sect.5, Chap.1 of this volume, will come into operation irrespective of which transmitter-receiver is in use or whether it is switched to receive or transmit.

14. The foregoing paragraphs described the operation of the installation when used for normal communication purposes; that is, with the V.H.F. - NORMAL and HOME remote control switch of the A.R.I. 18085 installation, set to the NORMAL position. When employed in conjunction with the A.R.I. 18085 installation, as described in the following paragraphs, the operation of the transmitter-receivers and the selection of the required frequency channel is similar to that described above but the V.H.F. - NORMAL and HOME switch is set to the HOME position to enable the transmitter-receiver in use to supply the A.R.I.18085 installation and bring the homing indicator into operation.

A.R.I. 18085

15. The setting-up and operating instructions for this installation are given in full detail in A.P.2898D, Vol.1, but for those who do not require this amount of detail, the following brief summary is given.

16. The power supply for this installation is derived from the particular V.H.F. transmitter-receiver with which it is employed. It is a wide-band installation providing homing facilities in azimuth and elevation, but not simultaneously. The installation is remotely controlled by three two-way switches which are situated together in the cabin. One of these switches is a two-pole switch marked V.H.F. - NORMAL and HOME, another is a single-pole switch marked AZIM and ELEV, while the third, also a single-pole switch, is marked MAX and MIN.

17. With the V.H.F. - NORMAL and HOME remote control switch set to the NORMAL position and No.1 V.H.F. transmitter-receiver switched ON, as described in

para.11, the power supplies and the L.F. signal output from No.1 transmitter-receiver are connected to the modulator via the contacts of a de-energized relay in the aerial junction box. At the same time, the communication aerial is connected, via the contacts of another de-energized relay, to the transmitter-receiver, thus normal communication facilities are obtained.

18. With No.1 transmitter-receiver still switched ON, the V.H.F. - NORMAL and HOME control switch set to the HOME position and the AZIM and ELEV switch set to AZIM, the supplies to the modulator unit are completed and relays in the aerial junction box are energized to disconnect the communication aerial from the transmitter-receiver. The V.H.F. output from the modulator is also fed to No.1 transmitter-receiver and the vertical pointer and its associated flag of the homing indicator, together with the port azimuth aerial are connected to the modulator. The starboard azimuth aerial is always connected to the modulator, thus the phase difference between the signals produced in these two aerials by the selected transmission will operate the installation and give azimuth homing facilities on the indicator.

19. When the AZIM and ELEV control switch is set to ELEV, the operation of the installation is similar to that described in para.18 with the exception that the horizontal pointer and its associated flag in the homing indicator, together with the elevation aerial, are connected to the modulator and the port azimuth aerial is disconnected from the modulator. The phase difference between the signals produced in the starboard azimuth and the elevation aerials by the selected transmission will now operate the installation and give elevation homing facilities on the indicator.

20. When No.2 transmitter-receiver is switched ON, as described in para.12, the operation of the installation is similar to that already described,

but the power supplies and LF signal output from No.2 transmitter-receiver are connected to the modulator and the output from the modulator is fed to No.2 transmitter receiver. The switch marked MAX. and MIN controls the sensitivity of the homing indicator and should, therefore, be placed in the MAX position when maximum sensitivity is required from the installation.

21. When it is required to use the transmitter-receivers for normal communication purposes, while the homing facilities are being employed, the homing installation may be overridden by the depression of the press-to-transmit push-switch. Operation of this switch disconnects the supply to the modulator and reconnects the communication aerial to the transmitter-receiver in use.

A.R.I.18012

22. When the tele-briefing socket at the end of the external cable is mated with the plug on the spring-loaded door in the underside of the rear fuselage, the tele-briefing relays E and F in the V.H.F. relay box are energized. These automatically transfer the pilot's mic.-tel. socket connection from the aircraft transmitter-receivers to the tele-briefing cable. This ensures that spurious responses are not present in the pilot's mic-tel. circuit due to the attenuation by the receiver circuit when operating the tele-briefing installation. At the same time, the indicator lamp is illuminated to indicate to the pilot that tele-briefing facilities are connected to the aircraft and that he can receive information from the system.

23. When speaking over the system, the pilot must keep the tele-briefing push-switch depressed. This push-switch energizes a relay in the tele-briefing building and connects the pilot's microphone to the landline, via an amplifier also located in this building. At the same time, a lamp lights in the

H.A.L.6.

building to indicate that the microphone is in circuit. For further information on this system, reference should be made to A.P.2876G, Vol.1.

SERVICING

General

24. Servicing of the wireless installation is fully covered in the appropriate Air Publication quoted in para.1 of this chapter, but any units suspected of being unserviceable should be carefully checked in-situ as described in the following paragraphs and, if found to be faulty, removed from the aircraft and taken into the workshop for rectification action as necessary. The location of the components is illustrated in fig.1 and 2, the interconnection in fig.3 and a wiring diagram of the power supplies will be found in Sect.5, Chap.1 of this volume.

Power supplies

25. If a fault is reported in the wireless installation, the power supplies should first be checked, in conjunction with the appropriate routing and theoretical diagram given in Sect.5, Chap.1 of this volume, to ensure that the trouble is not located in the aircraft electrical system. The voltage, both on and off load, must be tested and a check made to ensure that the connectors carrying the supply to the equipment are correctly assembled.

Cables and connectors

26. Servicing of the cables and connectors consists of the standard continuity and insulation resistance tests, together with a periodical examination throughout their entire length for any signs of damage to, or deterioration of, the insulation. If any defects are found, the complete cable or connector must be replaced; the type references of the connectors are given in fig.3. All the clips securing the cables and connectors to the structure must be examined for

RESTRICTED

signs of looseness and rectified as necessary to prevent chafing. Plug and socket connections must be checked to ensure that they are fitting properly and that the fixings are screwed fully home.

Mic.-tel test socket

27. To eliminate the necessity of using the pilot's mic.-tel. socket when adjusting the wireless installation and to enable the adjustments to be made from within the radio bay, a mic.-tel. test socket, connected in parallel with the pilot's socket, is provided. This test socket is stowed in a spring clip at the bottom of the V.H.F. relay box and is used in conjunction with a standard headset. It should be noted that when using this test socket, it will first be necessary to place the set selector switch to the position corresponding to the transmitter-receiver being adjusted, and to select the required frequency channel by use of the associated control unit, before commencing operations.

A.R.I. 18064

General

28. In-situ servicing of this installation is confined to security and functional checks of the equipment, together with elementary fault-finding. All other operations, including any which demand the removal of covers, require the prior removal of the unit or units concerned to the workshop for servicing as described in A.P.2538HA, Vol.1.

Security check

29. The following checks should be carried out on the various units of the installation, to ensure that the equipment is properly installed and secure:-

- (1) Check the tightness of the clamps holding the transmitter-receivers in their mounting racks.

- (2) Check the security of the resilient mounts on the mounting racks and ensure that the fixed mounting structure is secure.
- (3) Check that the set selector switch and control units are securely mounted.
- (4) Check the security of the aerials.
- (5) Ensure that the V.H.F. relay box is securely mounted.
- (6) Check that all the plugs and sockets are fitting properly and that the fixings are screwed firmly home.
- (7) Check that the test mic.-tel. socket is secure in its clip and that any strain on the pilot's mic.-tel. socket is taken up by the check-cord and not by the cable attached to the socket.

Functional check

30. After the installation has been set-up in accordance with the instructions given in A.P.2538HA, Vol.1, the in-situ functional check consists of ensuring that each transmitter-receiver and its associated control unit, relays, etc., are operating correctly. The recommended method is as follows:-

- (1) Connect a standard microphone and telephone headset to the pilot's mic.-tel. socket.
- (2) Place the set selector switch on the cabin port shelf to the No.1 position and ensure that the V.H.F. - NORMAL and HOME switch is in the NORMAL position.

- (3) Switch on the transmitter-receiver by selecting, on No.1 control unit, a suitable test frequency channel, as previously agreed with the control tower.
- (4) If the transmitter-receiver is operating correctly, signals will be heard in the telephones.

NOTE...

It should be remembered that time must be allowed for the set to warm up before signals can be heard.

- (5) Depress the press-to-transmit push-switch in the throttle twist grip and check that the signals cease.
- (6) Still depressing the press-to-transmit push-switch, call up the control tower in the normal manner and ask for a report of your transmission.
- (7) To obtain this report, release the press-to-transmit push switch and signals will again be heard.
- (8) Place the set selector switch to the No.2 position and check that the signals cease. Switch off No.1 transmitter-receiver.
- (9) Switch on No.2 transmitter-receiver by selecting, on No.2 control unit, a suitable test frequency channel, as previously agreed with the control tower.
- (10) If No.2 transmitter-receiver is operating correctly, signals will be heard on this frequency.

NOTE...

It should be remembered that time must be allowed for the set to warm up before signals can be heard.

H.A.L.6.

- (11) Repeat operations (5) to (7) to check that No.2 transmitter-receiver is transmitting correctly.
- (12) Place the set selector switch to the set No.1 position and check that signals cease. Switch off No.2 transmitter-receiver.
- (13) When the test is completed, remove the microphone and telephones from the pilot's mic.-tel. socket.

Fault finding

31. If a fault is reported, a careful test should be made, in-situ, in an attempt to locate the faulty unit. Before any other tests are made, the low tension source should be checked, the tightness of the connectors ensured and the voltage, both on and off load, tested. Any unit found to be faulty should be taken to the workshop for testing and repair. For full details of the fault finding and testing procedure, reference should be made to A.P.2538 HA, Vol.1. If the V.H.F. relay box is found to be faulty, it should be removed from the aircraft and replaced with a fully serviceable item. The faulty box should then be taken to the workshop for testing and repair and then returned to store to be held as a spare. When the aircraft is undergoing its Minor Servicing this box should be removed from the aircraft for a thorough check and adjustment to ensure that its operation is reliable in service.

A.R.I. 18085

General

32. Instructions for testing and aligning this installation, together with general servicing information are contained in A.P. 2898D, Vol.1, The installation should, however, be checked for security and an in-situ functional check made to ensure that it is operating correctly, as described in the following paragraphs.

RESTRICTED

Security check

33. To ensure that the equipment is properly installed, the following security checks should be carried out on the various units of the installations:-

- (1) Check the security of the modulator unit and aerial junction box.
- (2) Check the security of the resilient mounts on the mounting racks and ensure that the fixed mounting structure is secure.
- (3) Check that the homing indicator, control unit and remote control switches are securely mounted.
- (4) Check that the Type 1254 relay unit is securely mounted.
- (5) Check the security of the aerials.
- (6) Check that all the plugs and sockets are fitting properly and that the fixings are screwed firmly home.

Functional check

34. With the installation set-up in accordance with the instructions given in A.P.2898D, Vol.1, the in-situ functional check consists of ensuring that the equipment is operating correctly using a X.7049 test oscillator operating at a frequency covered by a crystal in the associated transmitter-receiver being employed during the test. The recommended method is as follows:-

- (1) Connect a standard microphone and telephone headset to the pilot's mic.-tel. socket.
- (2) Place the set selector switch to the No.1 position and the V.H.F. NORMAL and HOME control switch to the NORMAL position.
- (3) Switch on No.1 transmitter-receiver by

selecting, on No.1 control unit, the frequency channel covered by the test oscillator.

- (4) With the test oscillator switched ON and situated at a distance not exceeding 40 ft. from the communication aerial, the modulated carrier of the oscillator should be heard in the telephones.
- (5) Place the V.H.F. NORMAL and HOME switch to the HOME position, the AZIM and ELEV switch to the AZIM position and check that the signals from the test oscillator cease. Also check that the flag at the bottom of the homing indicator disappears and that the vertical pointer of the indicator moves from its zero position, thus indicating correct azimuth operation of the installation.
- (6) Place the AZIM and ELEV switch to the ELEV position. Check that the flag at the right-hand side of the homing indicator disappears and that the horizontal pointer moves from its zero position, thus indicating correct elevation operation of the installation.
- (7) Depress the press-to-transmit push-switch. Check that the pointer returns to the zero position and that the flag re-appears, thus checking the operation of the transmitter overriding facilities.
- (8) Place the V.H.F. - NORMAL and HOME switch to the NORMAL position, the set selector switch to the No.2 position and repeat operations (3) to (7) using No.2 transmitter-receiver.

Fault finding

35. Fault diagnosis for this installation is covered in A.P.2898D, Vol.1. If a fault is reported, the low tension source should be checked, the tightness of the connectors ensured and the voltage, both on and off load, tested before any other checks are

made. A careful, in-situ check should then be made in an attempt to isolate the trouble, and the faulty unit taken to the workshop for testing and repair.

A.R.I. 18012

General

36. For a detailed description of the servicing necessary for the tele-briefing installation, reference should be made to A.F.2876G, Vol.1.

Final check

37. After servicing the wireless installation, ensure that all the equipment is left switched off and that all access doors, removed to gain access to the equipment, are correctly replaced and secured.

REMOVAL AND ASSEMBLY

General

38. The recommended procedure for removing the majority of the components which comprise the wireless installation is given in the following paragraphs. The method of assembly is, in general, the reversal of the removal sequence, but when there is any special assembly feature it is covered by a note in the appropriate paragraph. Before removing or replacing any component, the aircraft must be rendered electrically safe, as described in Group A.1 of Sect.5, Chap.1 of this volume.

Transmitter-receivers 1985 and 1986

39. The recommended method of removing these transmitter-receivers is as follows:-

- (1) Render the aircraft electrically safe (Sect.5, Chap.1, Group A.1).
- (2) Disconnect the five connectors from transmitter-receiver 1986, fit approved caps and covers to the plugs and sockets. Stow and connectors clear of the set.

Unscrew the two knurled screws at the front of the mounting tray and allow these to drop clear of the retaining catches on the set.

- (4) Disengage the spigots at the rear of the transmitter-receiver from the mounting tray by using the handles to withdraw the set along the tray. Still using the handles, carefully remove the set from the aircraft.
- (5) Repeat the above procedure for the removal of transmitter-receiver 1985.

Type 7747 modulator unit

40. To remove this unit, proceed as follows:-

- (1) Render the aircraft electrically safe (Sect.5, Chap.1, Group A.1).
- (2) Disconnect the six connectors from the modulator unit, fit approved caps and covers to the plugs and sockets and stow the connectors clear of the modulator.
- (3) Unscrew the two knurled screws at the aft end of the mounting tray and disengage these from the retaining catches on the modulator.
- (4) Disengage the spigots at the forward end of the mounting tray from the modulator by withdrawing the unit along the tray.
- (5) Carefully withdraw the modulator from the tray and remove it from the aircraft.

Type 7089 aerial junction box

41. The recommended procedure for removing this junction box is as follows:-

- (1) Render the aircraft electrically safe (Sect.5, Chap.1, Group A.1).

- (2) Disconnect the ten connectors from the aerial junction box, fit approved caps and covers to the plugs and sockets and stow the connectors clear of the unit.
- (3) The junction box may now be removed from its mounting plate by withdrawing the four bolts, located two at each end of the unit.

mounting lugs located one at each end of the box and release the box from its attachment brackets by withdrawing it downwards to disengage the locating hooks.

- (4) The relay box may now be removed from the aircraft, complete with mic.-tel. test socket.

42. Paragraph deleted by Hawker Amendment List No.6. |

Type 1254 relay unit

43. The recommended method of removing this relay unit is as follows:-

- (1) Render the aircraft electrically safe (Sect.5, Chap.1, Group A.1).
- (2) Disconnect the leads of cable assembly F.74 from the terminal block on the relay unit and unclip this cable assembly from the unit.
- (3) Disconnect the connectors from the aerial and modulator sockets on the relay unit.
- (4) The relay unit may now be removed by unscrewing the three screws securing the unit to the bracket on frame 19.

V.H.F. relay box

44. The box is designed for easy removal, being supported on quick-release mountings. The recommended method of removing the box is as follows:-

- (1) Render the aircraft electrically safe (Sect.5, Chap.1, Group A.1).
- (2) Disconnect the five connectors from the relay box, fit approved caps and covers to the plugs and sockets and stow the connectors clear of the box.
- (3) Remove the two bolts passing through the

*Type 228 and 229 aeriels

45. The recommended method of removing either of these aeriels, complete with their matching stubs, is as follows:-

- (1) Render the aircraft electrically safe (Sect. 5, Chap.1, Group A.1)
- (2) Remove the sixteen countersunk-headed bolts from around the periphery of the aerial access panel in the top surface of the outer wing.
- (3) Raise the access panel to gain access to the aerial bollard and remove the moulded cover from the bollard.
- (4) Unscrew the top retaining nut from the end of the aerial rod, take off the two nuts securing the U - shaped bonding clip, and remove the aerial connector from the rod.
- (5) The access panel, complete with aerial and matching stub, may now be removed from the wing by releasing the balloon cord.
- (6) To remove the aerial unit from the panel, it is necessary to release the mounting bracket by unscrewing the four stiffnuts from the bolts securing the bracket to the panel, taking care to retain the six washers. The aerial, matching stub and mounting bracket may now be removed from the panel by withdrawing the aerial rod through the rubber grommet.

- (7) To remove the aerial unit from the mounting bracket, unscrew the four stiffnuts from the bolts securing the aerial to the mounting bracket, taking care to retain the washers.

NOTE...

When assembling the aerial and mounting bracket to the access panel, care must be taken to ensure that the earthing straps are assembled between two washers under the nuts on the bolts securing the mounting bracket to the panel and that the matching stub is assembled on the opposite side to the earthing straps and snugly coiled and clipped as found before removal. When assembling the access panel to the wing ensure that the mating surfaces are scraped clean to provide a good electrical contact.

Azimuth aeriels

46. The recommended method of removing either of these aeriels is as follows:-

- (1) Render the aircraft electrically safe (Sect.5, Chap.1, Group A.1).
- (2) Gain access to the aerial by removing the access door in the centre fuselage adjacent to the aerial.
- (3) At the aerial, release the connector from the aerial mounting side plates by removing the clip.
- (4) Disconnect the aerial connector from the aerial rod by removing the nut, bolt and washer securing the connector to the aerial lug.

- (5) The aerial may now be released from its mounting structure by removing the four bolts securing the aerial base to the side plates.

- (6) The aerial, complete with base, may now be removed from the aircraft by withdrawing it downwards through the grommet and out of the access door.

Elevation aerial

47. The recommended method of removing this aerial is as follows:-

- (1) Render the aircraft electrically safe (Sect.5, Chap.1, Group A.1)
- (2) Gain access to the aerial by opening the radio bay access doors.
- (3) Release the aerial connector from the aerial mounting bracket by removing the clip and disconnect the connector from the aerial rod by removing the nut and washer from the top of the rod.
- (4) The aerial, complete with its base, may now be released from its mountings by removing the four bolts securing the base to the mounting brackets, taking care to retain the bonding springs, which are attached by the two bottom bolts.

NOTE...

When re-assembling the aerial ensure that the that the fuel drain pipe is secured by the top aft fixing bolt and that the bonding springs are replaced correctly. Ensure that the bonding springs, aerial mounting brackets and the contact plates on the radio access doors are clean and making a good electrical contact.

Type 382 control units

48. To remove these control units, proceed as follows:-

- (1) Render the aircraft electrically safe (Sect.5, Chap.1, Group A.1).
- (2) Unscrew the two screws securing the bomb and R.P. control box to the cabin port shelf and lift this box to gain access to the connectors assembled to the control units.
- (3) Disconnect the connectors from the control units.
- (4) The control units may now be removed by unscrewing the two screws and one bolt securing each unit.

Type 7746 control unit

49. The recommended method of removing this control unit is as follows:-

- (1) Render the aircraft electrically safe (Sect.5, Chap.1, Group A.1).
- (2) Disconnect the three connectors from the unit, fit approved caps and covers to the plugs and sockets and stow the connectors clear of the unit.
- (3) The control unit may now be removed from the cabin by releasing the three screws securing it to the mounting brackets on frame 14.

Radio mounting structure

50. The lower radio mounting structure extends from frame 16 to frame 19, being bolted to these two frames, thus when breaking down the aircraft at the front transport joint, as described on Sect.3, Chap.1 of this volume, it is necessary to remove

this structure. The recommended procedure is as follows:-

- (1) Render the aircraft electrically safe (Sect.5, Chap.1, Group A.1)
- (2) Remove the gun-firing panel and the Type 200 inverter (Sect.5, Chap.1, Group A.2).
- (3) Remove the transmitter-receivers 1985 and 1986 (para.39).
- (4) Remove the transmitter-receivers 3121 and 3708 (Sect.6, Chap.2).
- (5) Remove the V.H.F. relay box (para.44).
- (6) Disconnect the D.M.E. connector leads and the leads of cable assembly TS.3 from T.B.74
- (7) Stow all the disconnected cables clear of the mounting structure, releasing any clips and strapping as found necessary.
- (8) Release all clips and strapping from the cables attached to the mounting structure to ensure that the removal of the structure will be unencumbered.
- (9) Release the mounting structure from frames 16 and 19 by removing the nuts, bolts and washers securing it to the brackets on these frames. Remove the structure from the aircraft.
- (10) The aft platform of the upper radio mounting structure, which supports the aerial junction box, is also attached to brackets on frame 19, thus the junction box must be removed and these attachments disconnected when breaking down the aircraft. It is not, however, necessary to remove the upper radio mounting structure.

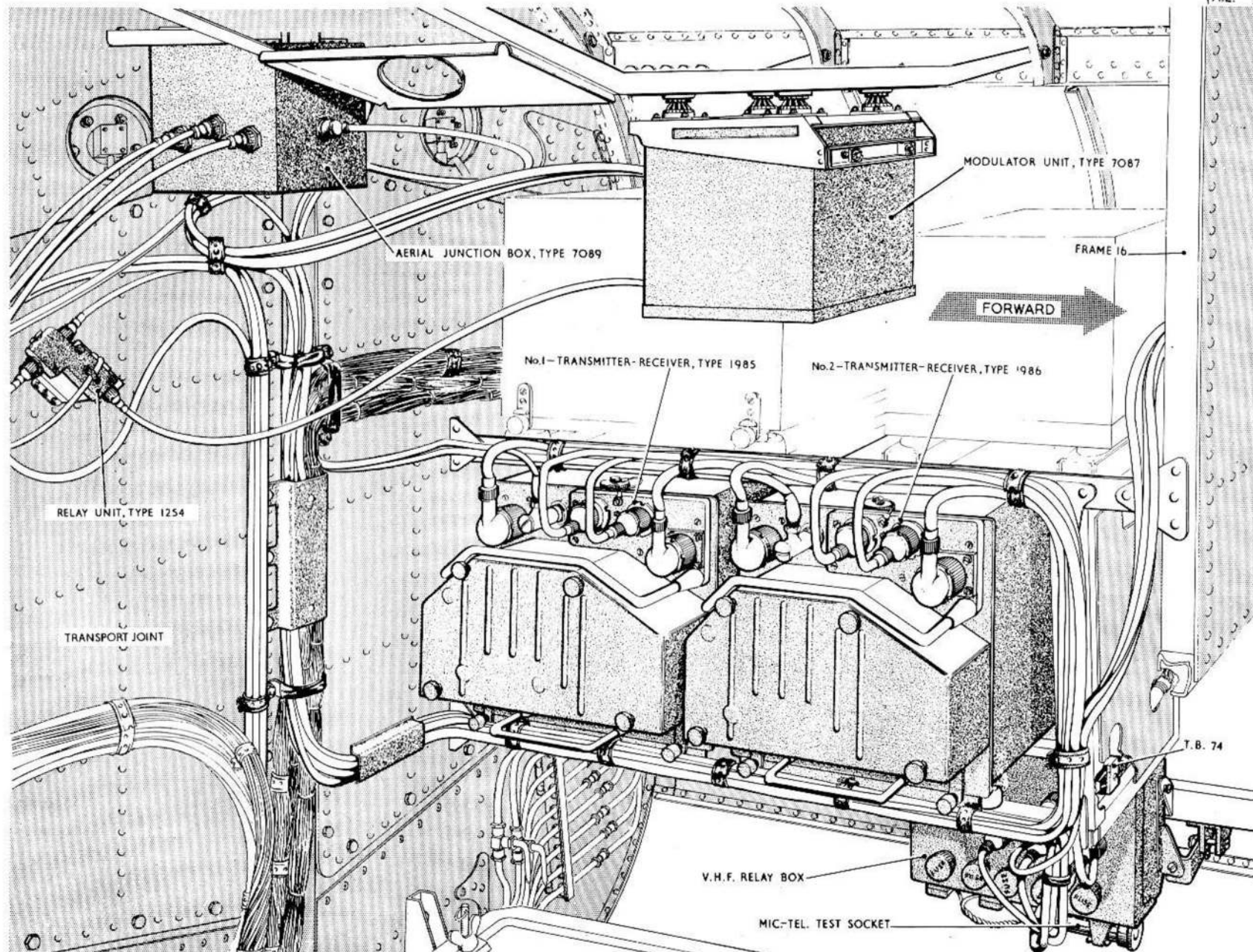

FIG. 1. LOCATION (I)
RESTRICTED

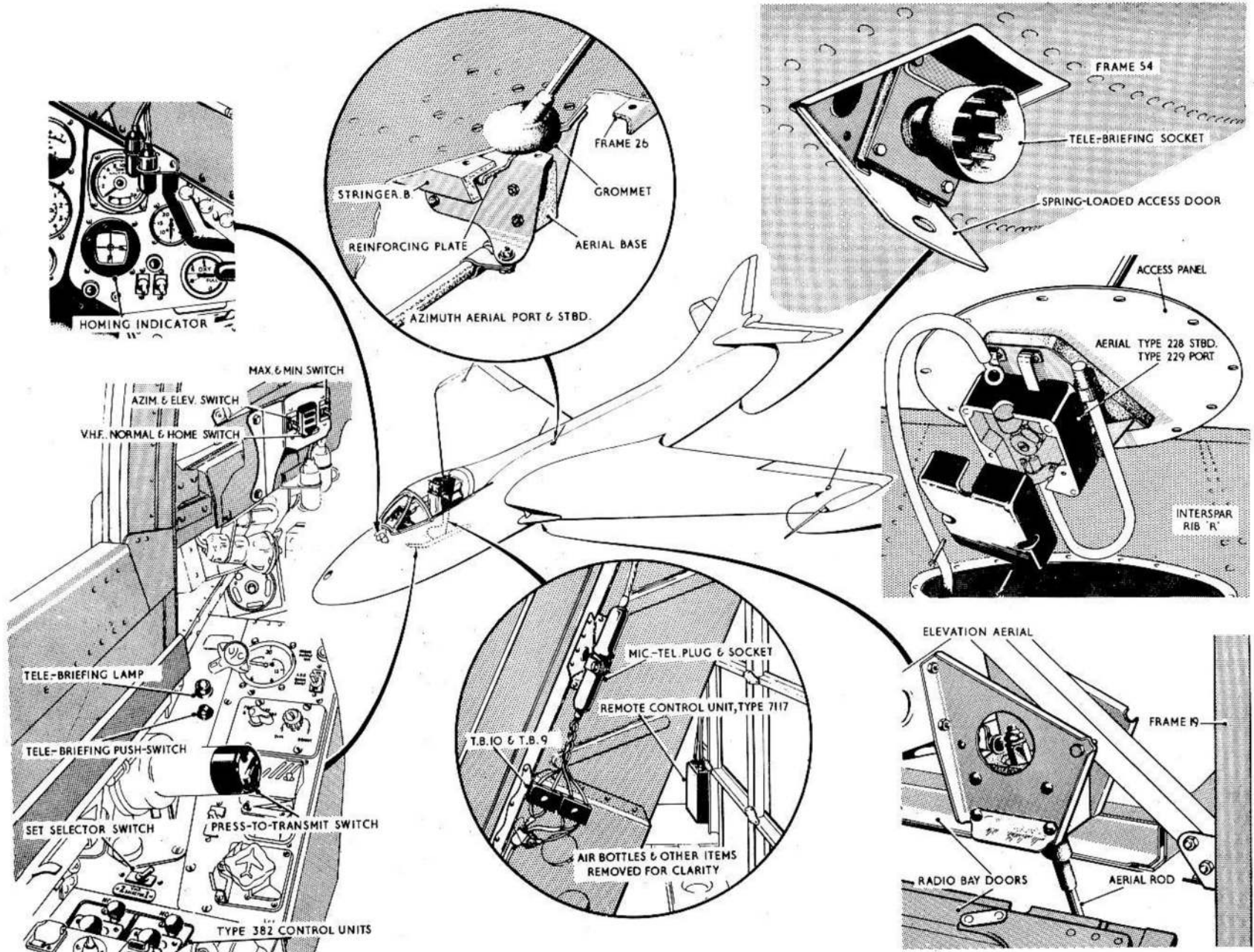
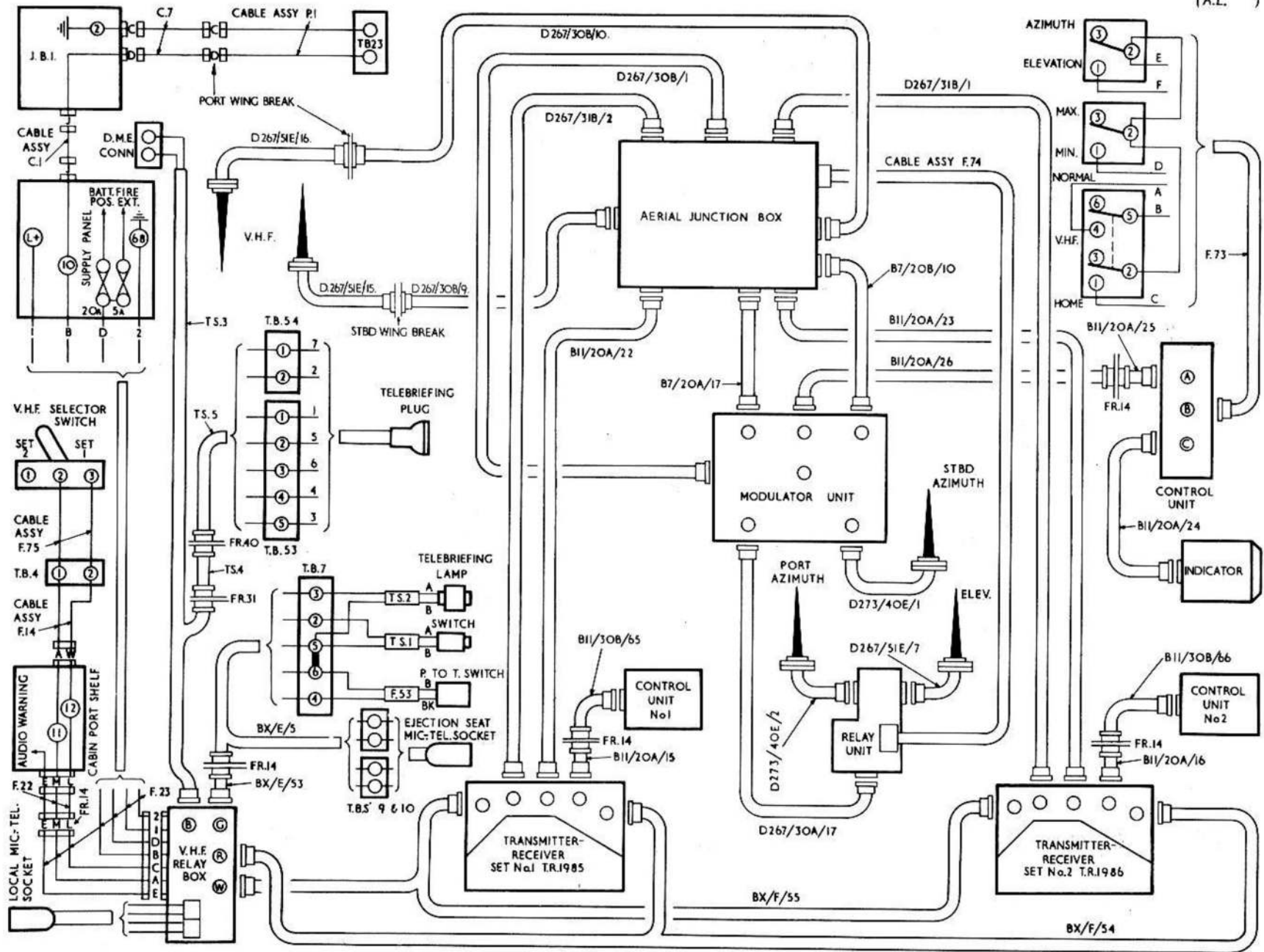

FIG. 2. LOCATION (2)
RESTRICTED



**FIG. 3 INTERCONNECTION
RESTRICTED**

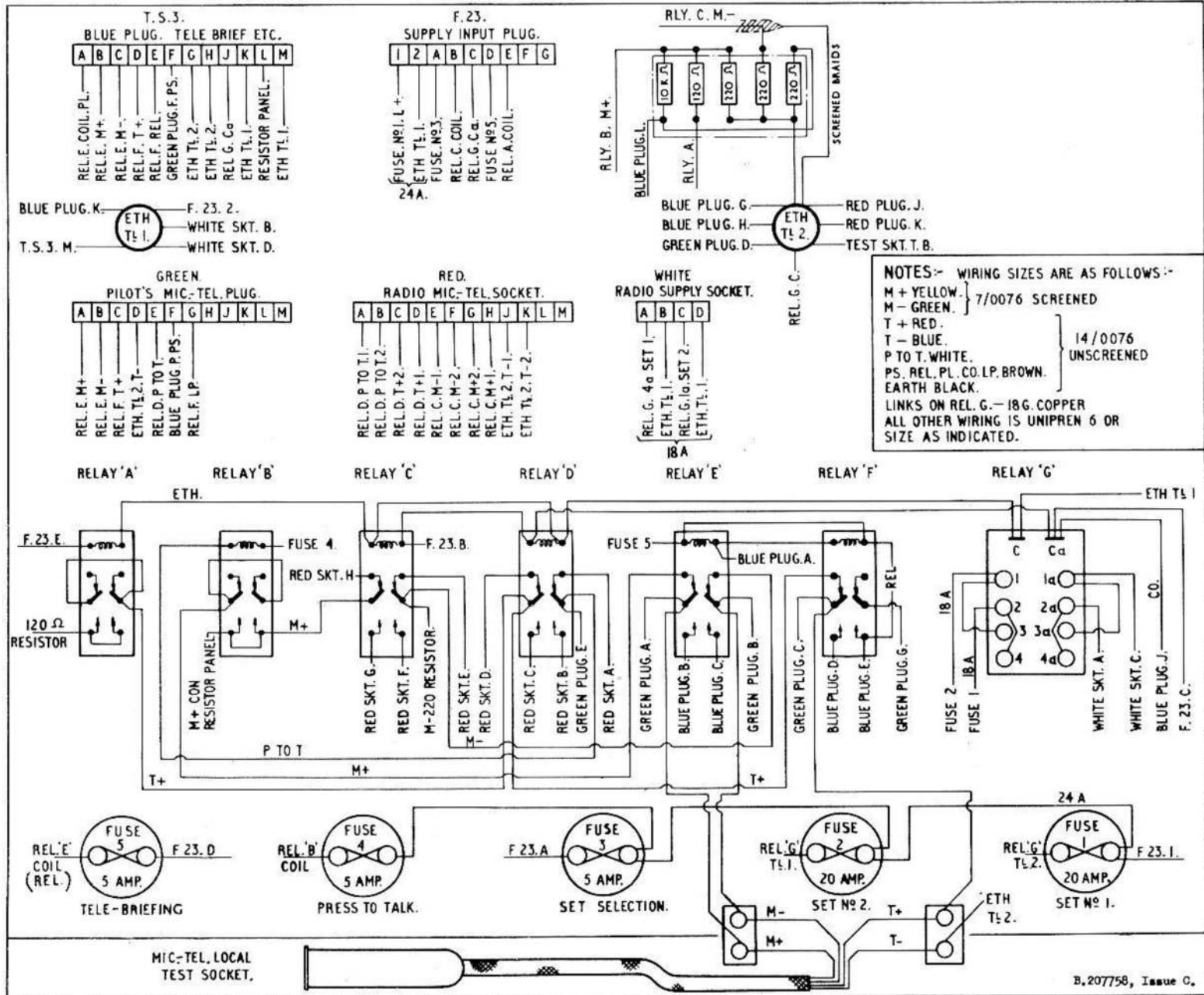

FIG. 4 WIRING OF V.H.F. RELAY BOX

This file was downloaded
from the RTFM Library.

Link: www.scottbouch.com/rtfm

Please see site for usage terms,
and more aircraft documents.

